

ZX HOIST



THE BEST JUST GOT BETTER

Street



Certificate No. FM13635



MADE IN ENGLAND

"PERFORMANCE THROUGH EVOLUTION AND INNOVATION"

"To achieve the highest possible levels of performance and reliability it is necessary to continuously learn from experience,

..Invest in R&D and pay attention to even the smallest possibility for improvement. Only then can new bench marks for efficient performance and operating reliability be set. Only then can a technology be said to be truly proven."



The new ZX hoist generation evolved from the most rigorous application of this philosophy. The original ZX hoist which was launched 10 years ago established Street as a world leader in hoisting technology and has been the company's best ever selling product with an unparalleled record for reliability and endurance in a vast range of applications and environments worldwide. When it came to developing the next generation it was therefore completely logical to retain the best aspects, such as the highly successful parallel configuration of the motor and drum. Every function of the hoist was reviewed and a whole series of innovations applied to provide new levels of user-friendliness and performance.



Finally we optimised every component using the latest finite element design techniques and a passionate commitment to every performance detail. The result is an easy to operate high endurance hoist incorporating state-of-the-art technology.

A hoist designed to fulfill expectations and improve our customer's productivity. A hoist for tomorrow's world in which only the most productive will prosper.

The new ZX Hoist formula for safe and efficient lifting



The new ZX hoist sets the benchmarks in the crane industry. It provides a series of unique benefits for the user. ZX epitomises intelligent design - for easy load handling - impressive performance - exceptional safety levels.

We invite you to compare the following hoist specification with any in the world and we think you will agree ZX represents unbeatable value for money and great investment.

"A hoist designed to fulfill expectations and improve our customer's productivity. A hoist for tomorrow's world in which only the most productive will prosper."

CLASSIFICATION OF MECHANISMS

FEM 9.511	1D _m	1C _m	1B _m	1A _m	2 _m	3 _m	4 _m	5 _m
BS 2573 P2	M1	M2	M3	M4	M5	M6	M7	M8
Hoist	Intermittent ratio (R1%)		25	30	40	50	60	>60
	No. of starts per hour (S/h)		150	180	240	300	360	>360
	No. of cycles per hours (C/h)		25	30	40	50	60	>60
Trolley	Intermittent ratio (R1%)		20	25	30	40	50	60
	No. of starts per hour (S/h)		120	150	180	240	300	360
	No. of cycles per hours (C/h)		20	25	30	40	50	60
Two-Speed Double polarity motor								
No. of starts per hour (S/h)	Main speed	1/3 (33.3% of total starts per hour)						
	Slow speed	2/3 (66.7% of total starts per hour)						
Operating time per day	Main speed	2/3 (66.7% of average operating time per day)						
	Slow speed	1/3 (33.3% of average operating time per day)						
Used in temporary duty	Operating time at main speed (min.)	15	15	30	30	60	>60	
	Operating time at slow speed (min.)	2.5	3	3.5	4	5	6	
	Maximum number of starts per hour (S/h)	10	10	10	10	10	10	

For applying to the hoist mechanisms are classified into the groups depending on operating conditions

The group into which a mechanism is classified is determined by the following factor:

- Class of operating time
- Load spectrum

Class of operating time

The class of operating time indicates the average period per day during which a mechanism is in operation (see table 1). A mechanism is considered to be in operation when it is in motion.

For mechanisms not regularly used during the year the average operating time per day is determined by the ratio of the annual operating time to 250 working days per year.

The higher classes of operating time apply only in such cases where a mechanism is operated during more than one shift per day.

Table 1

Average operating time per day (hours)

$$\text{Operating time/day (h)} = \frac{2 \times \text{lifting height (m)} \times \text{number of cycles per hour} \times \text{working time/day (h)}}{60 \text{ (minutes per hour)} \times \text{lifting speed (m/min)}}$$

Lifting height = The average hook travel under actual operating conditions (meter)

Cycles per hour = The average number of complete ascent/descent operations in an hour

Working time/day = The time during which the hoist is used on a working day (hour)

Lifting speed = The average lifting speed (normally the maximum lifting speed) at which the load cycles are performed. (Meter per minute)

Class of operating time	Average operating time per day	Calculated total operating time
FEM	BS	(hours)
V0.06	T0	≤ 0.12
V0.12	T1	≤ 0.25
V0.25	T2	≤ 0.5
V0.5	T3	≤ 1
V1	T4	≤ 2
V2	T5	≤ 4
V3	T6	≤ 8
V4	T7	≤ 16
V5	T8	> 16

Load spectrum

The load spectrum indicates to what extent a mechanism or part thereof is subject to maximum stress or whether it is subject to smaller load only.

Table 2

For an exact classification into groups the cubic mean value k referred to the safe working load is required. It is calculated by using the following formula :

$$k = \sqrt[3]{(\beta_1 + \gamma)^3 \cdot t_1 + (\beta_2 + \gamma)^3 \cdot t_2 + \dots + \gamma^3 \cdot t_\Delta}$$

Where : $\beta = \frac{\text{useful or partial load}}{\text{safe working load}}$

$\gamma = \frac{\text{dead load}}{\text{safe working load}}$

$t = \frac{\text{operating time under useful or partial load and dead load}}{\text{total operating time}}$

$t_\Delta = \frac{\text{operating time under dead load only}}{\text{total operating time}}$

Four load spectrum are distinguished which are determined by the definitions given and by the ranges covered by the cubic mean values k as listed in table 2

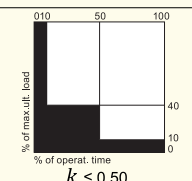
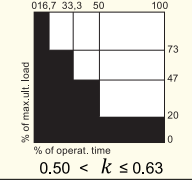
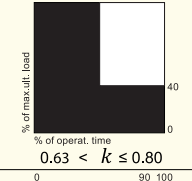
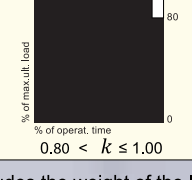
Load spectrum		Definitions	Cubic mean value
FEM	BS		
1 (light)	L1	Mechanisms or parts thereof, Usually subject to very small Loads and in exceptional cases Only to maximum loads	 $k \leq 0.50$
2 (medium)	L2	Mechanisms or parts thereof, Usually subject to small loads But rather often to maximum load	 $0.50 < k \leq 0.63$
3 (heavy)	L3	Mechanisms or parts thereof, Usually subject to medium Loads but frequently to Maximum loads	 $0.63 < k \leq 0.80$
4 (very heavy)	L4	Mechanisms or parts thereof, usually subject to maximum or almost maximum loads	 $0.80 < k \leq 1.00$

The formular given above for the cubic mean value k excludes the weight of the load carrying means.

This is acceptable if the ratio $\frac{\text{Weight of the load carrying means}}{\text{safe working load}} \leq 0.05$

By applying **The Classes of operating times** and **The Load Spectrum**,

The Mechanisms are classified into 8 groups :

Table 3

Classification of Mechanisms into 8 groups

Load spectrum		Class of operation time										
		V 0.06	V 0.12	V 0.25	V 0.5	V 1	V 2	V 3	V 4	V 5		
		T 0	T 1	T 2	T 3	T 4	T 5	T 6	T 7	T 8		
		Average operating time per day in hours										
FEM	BS	Cubic mean value	≤ 0.12	≤ 0.25	≤ 0.5	≤ 1	≤ 2	≤ 4	≤ 8	≤ 16	> 16	
1 (light)	L1	$k \leq 0.50$			1 D _m	1 C _m	1 B _m	1 A _m	2 _m	3 _m	4 _m	
					M1	M2	M3	M4	M5	M6	M7	
2 (medium)	L2	$0.50 < k \leq 0.63$			1 D _m	1 C _m	1 B _m	1 A _m	2 _m	3 _m	4 _m	5 _m
					M1	M2	M3	M4	M5	M6	M7	M8
3 (heavy)	L3	$0.63 < k \leq 0.80$			1 D _m	1 C _m	1 B _m	1 A _m	2 _m	3 _m	4 _m	5 _m
					M1	M2	M3	M4	M5	M6	M7	M8
4 (very heavy)	L4	$0.80 < k \leq 1.00$			1 C _m	1 B _m	1 A _m	2 _m	3 _m	4 _m	5 _m	
					M2	M3	M4	M5	M6	M7	M8	

The result of the classification of mechanism into groups according to table 3 is that the same life, expressed in years, may be expected for these machines under all load spectrum and average operating times per day. This applies on condition that the life of the individual component depends on the third power of the load.

The average daily operating time with in the classes of operating times are doubled as follows:

1. Within a group by passing into a lower load spectrum (progression 1.25), because $1.25^3 = 2$.
2. Within a load spectrum by passing into a higher group and derating the SWL by the factor of 1.25, because $1.25^3 = 2$.

ZX HOIST: operating and safety features.

IP 54 (Optional IP55) steel electrical control cubicle.

- Functional design with hinged door makes all components accessible.
- All electrical equipment incorporates heavy duty, quick release, plug and socket cable connectors for fast simple assembly.
- Better heat dissipation by the finned aluminium heat-sink to transfer heat out of the control cubicle when inverters are used on travel.
- Inverter control for trolley drive
- A phase failure relay prevents uncontrolled movement of the hoist if should one or more phases of incorret.
- Hours in service meter records the total time the hoist motor is energised.
- Panel wiring is ferruled and fully identified to the connection terminal.



Direct drive trolley with flangeless cross travel wheels and side rollers for high durability and reduced wear.

- The monorail trolley design is an outstanding feature of the Street design concept.
- It is proven by experience and generally accepted in the industry that for long term reliability and durability in travel gearing the trolley wheel should be directly driven, avoiding the need for an overhung pinion driving a spur on the trolley wheel.
- Direct drive via hardened and precision ground gears permanently immersed in oil.
- The traverse drive is removable without the need to remove or interfere with gearing or travel wheels. The trolley wheels are also easily removable.
- Sealed for life self aligning permanently lubricated bearings in the trolley frame ensure long life even under maximum loading.
- Sturdy flangeless steel wheels and guide rollers eliminate the problem of wheel flange wear and increase beam life.

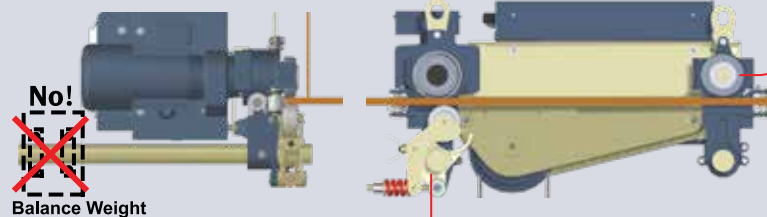
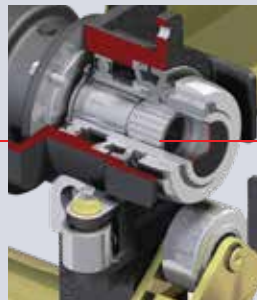
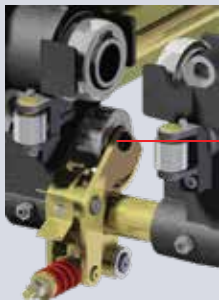

Trolley reaction roller avoids the need for a counter weight to in crease wheel life.

- Sprung roller acting on the underside of the beam eliminates the need for a counterweight.
- Increases life of the wheel rolling surface as a result of lighter hoist weight.
- Pre-loading on the mechanism significantly reduces wheel slip on light load or no load start up.
- Reduced shipping and transport cost as a result of lower weight and volume.
- Caters for beam flange thickness up to 35mm.

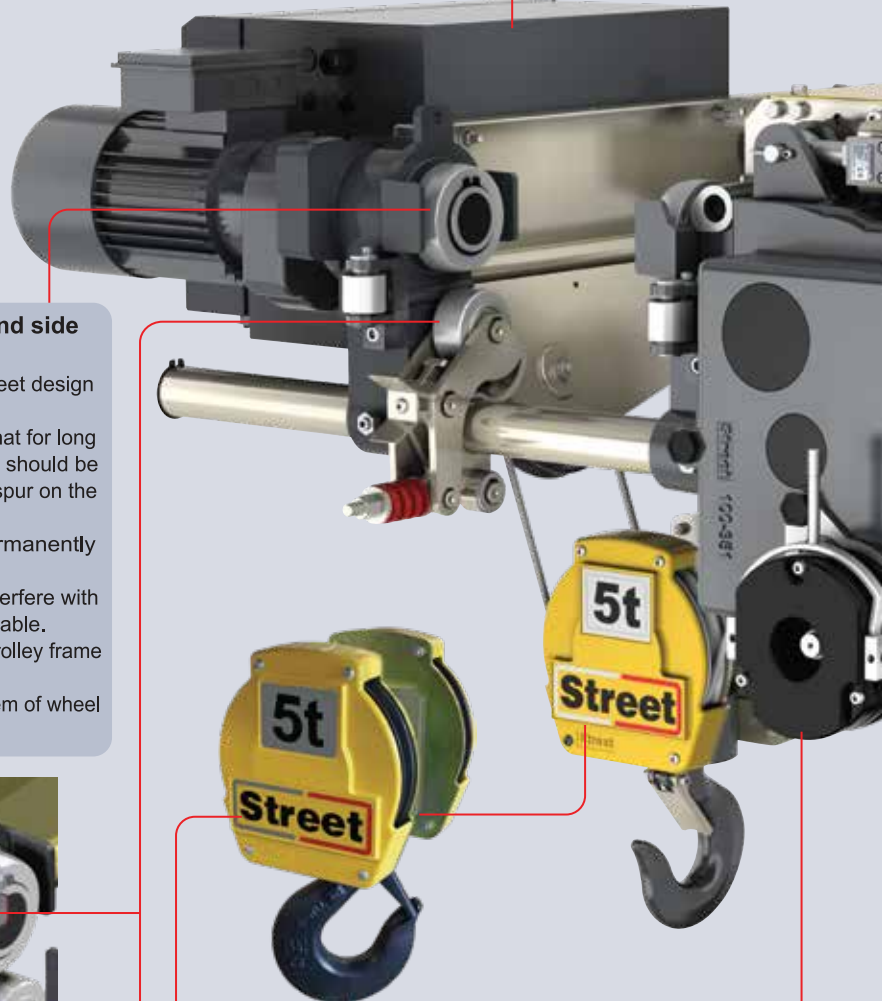

Superior load safety.

- A hoist brake acts on a gearbox shaft not a motor shaft as is the case with competitor hoists
- When the hoist brake is applied, the load will remain secure even if the hoist motor is removed
- Automatic braking in the event of a power failure
- Low maintenance DC disk brake fitted on gearbox shaft-ensures load
- Remains secure in event motor shaft or coupling failure.
- Health and safety compliant asbestos free brake linings.
- Hand-release mechanism fitted as standard.

Bottom Block

- New ergonomic design for improved safety and handling
- "Sealed for life" maintenance free bearings fitted in all sheaves.
- Robust cast aluminium sheave covers.
- Spring loaded safety catch fitted as standard.

Patented torque arm safe load cut-out device (capacity restrictor)

- Protects the operator and the machine.
- Measures all the load the hoist mechanism is transmitting (not just the load in one or two ropes).
- Can be easily adjusted to the required capacity.
- Does not reduce available height of lift.
- Activated directly by the load, does not rely on measuring electrical current

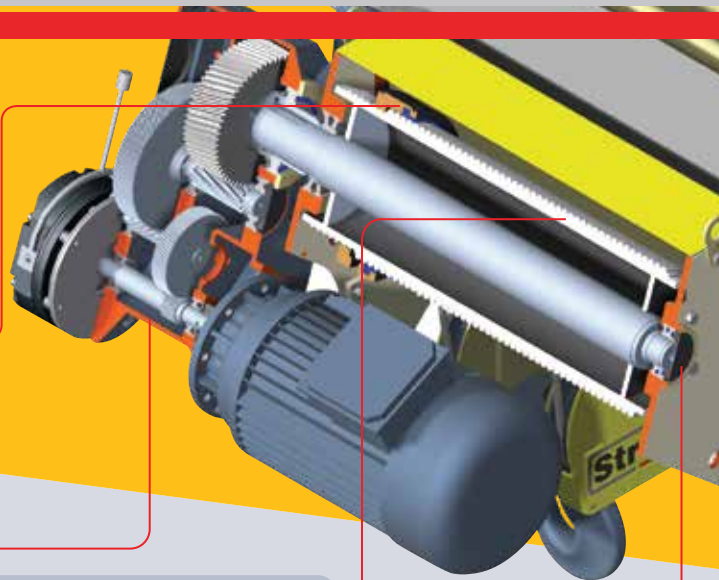

Over-hoisting and over-lowering limit switches.

- Over-hoisting and over-lowering of the hook are prevented by individual shunt limit switches (one for over-hoist and one for over-lower). The switches are activated by the rope guide as it travels along the drum and the cut-out positions can be adjusted to suit the application.

High-strength galvanised wire rope.

- Compact strand structure with improved tensile strength.
- Enhanced fatigue strength for durability under cyclic bending.
- Galvanised steel rope strands for maximum corrosion protection.

Extra hoist drum security

- Continuous shaft through the hoist drum
- Barrel retention "spigots" self aligning bearings at each end of the drum to take up deflection



Heavy duty rope guide ensures positive rope scrolling and prevents damage in 'slack-rope' conditions.

- Robust functional design - the product of 60 years experience.
- Specially selected oil impregnated nylon material, highly resistant to breaking or permanent distortion. The material properties include self-lubrication and a good elastic memory range.
- Spring loaded inner clamping band to prevent rope build up damaging the rope guide if the operator lowers the hook block onto an object and causes slack in the ropes.
- Rope guide reduces wear on the hoist rope and drum.
- Easy to install.



Precision hoist gearbox with hardened and ground gears/drive shafts

- Gears permanently immersed in oil for safety and reliability year after year.
- The hollow shaft gearbox directly drives the hoist drum shaft, avoiding the need for final reduction by an overhung pinion and barrel spur arrangement outside the gearbox.
- Gears are case hardened and precision ground with special tip relief and crowning for smooth running and high reliability.
- Zx6 gearbox now improved M5 rating for 5 and F speeds utilising H4 and H5 motors respectively
- Gear train can be viewed through the removable inspection cover

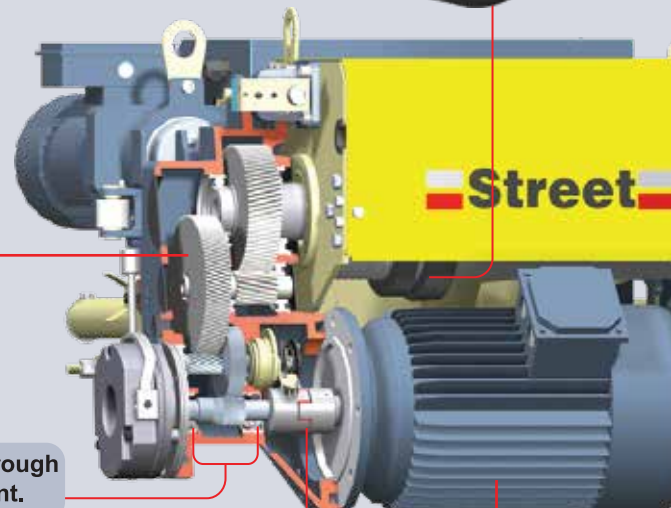

Continuous primary gear shaft through in double bearing to set alignment.



- Close coupled hoist motor mounting with vibration damping coupling prolong motor and gearbox life.

Designed for improved ventilation and easy access to key components.

- External hoist motor to optimise cooling and maximise accessibility.
- Remote mounting of the hoist motor and bracket prevents heat transfer in either direction.
- Flange mounting IEC Standards 60034-7
- Heavy duty two speed hoist motor with built in protection against over-heating.
- Cylindrical rotor fan cooled design.
- Overheating protection in the motor winding is standard.
- Class "F" insulation 155°C
- Ambient temperatures -20°C up to +50°C at an altitude less than 1000m. above sea level
- Humidity 5-95% Non condensing
- I.P 54 (Optional IP55) protection against ingress of dust particles and water.

SINGLE GIRDER TROLLEY

ZX ELECTRIC HOIST MODELS



MODEL : ZX06 SINGLE GIRDER HOIST
Capacity of 2.5, 3.2 and 5 Tons

**** Trolley reaction roller Avoids the need for a counter weight to increase wheel life direct drive trolley with flangeless cross travel wheels and side rollers for high durability and reduced wear*

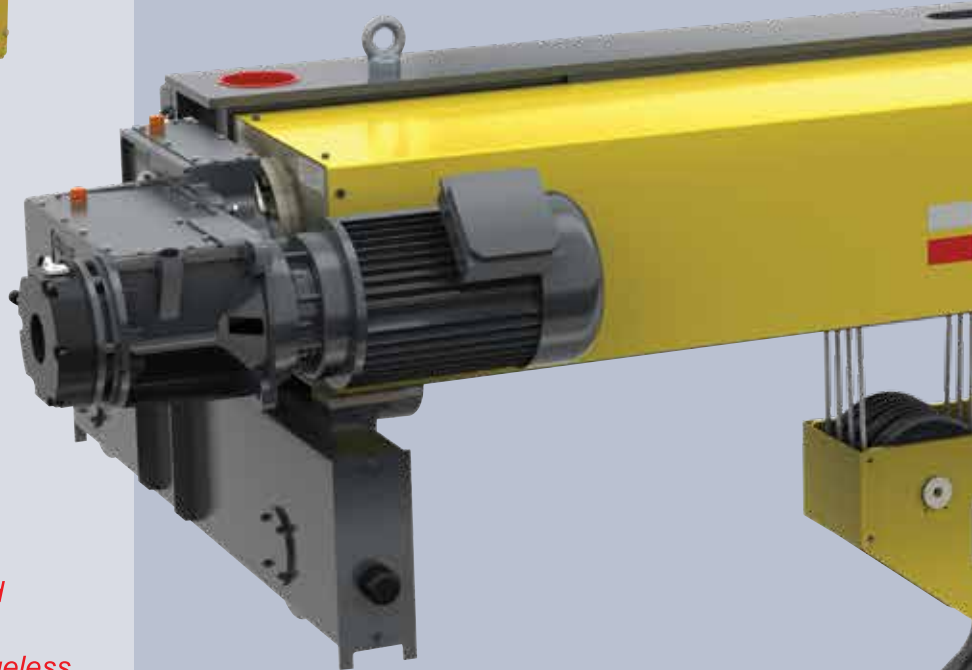

MODEL : ZX08 SINGLE GIRDER HOIST ▶▶
Capacity of 2.5, 3.2, 5, 6.3, 8, 10 and 12.5 Tons



◀◀ MODEL : ZX08 SINGLE GIRDER HOIST
STANDARD HEAD ROOM

Capacity of 10, 12.5, 16, 20 and 25 Tons



Special features :

- Low head room & Low profile bay.
- Mechanism torque arm safe overload device.
- Direct drive cross travel wheel on trolley.
- A Phase failure relay prevent movement of the hoist.
- Cross travel drives control by inverter 2 step variable speed.
- The finned aluminium heat-sink to transfer heat out IP 54 (Optional IP 55)
- Vibration damping coupling prolongs hoist motor and gear box life.
- External electro magnetic DC disc brake on gear box with hand release.
- 2 speeds heavy duty poles change hoist motor with built in the overhead protection.
- Precision engineered and headroom gears permanently immersed in oil.
- Heavy duty engineering nylon rope guide.
- High strength galvanised wire ropes.
- Quick release heavy duty plug & socket connection.
- Special models are available for ambient temperatures 50 Degree C.

DOUBLE GIRDER TROLLEY

ZX ELECTRIC HOIST MODELS



◀ MODEL : ZX10 DOUBLE GIRDER HOIST
DOUBLE GEAR BOX TWIN ROPE HOIST
Capacity of 20, 25, 32, 40, 50, 63 and 80 Tons



MODEL : ZX08 DOUBLE GIRDER HOIST ▶▶
Capacity of 10, 12.5, 16, 20 and 25 Tons



◀ MODEL : ZX10 DOUBLE GIRDER HOIST
SINGLE GEAR BOX SINGLE ROPE HOIST
Capacity of 20, 25 and 32 Tons



▲ MODEL : ZX06 DOUBLE GIRDER HOIST
Capacity of 2.5, 3.2 and 5 Tons

◀ MODEL : ZX08 DOUBLE GIRDER HOIST
Capacity of 2.5, 3.2, 5, 6.3, 8, 10 and 12.5 Tons



single girder



ZX06 Single Girder Hoist

Low headroom construction is a standard design feature of ZX monorail hoists with capacities ranging from 0-5 tonne for ZX6 models and 0-25 tonne for the ZX8.

At each capacity we offer a huge combination of lifting speeds and lifting heights giving the user maximum flexibility.

All popular capacities are available with M5 duty ratings (FEM 2m) and in most capacities duty ratings of M6 (FEM 3m) and M7 (FEM 4m) are also available.

Low headroom models are fully adjustable to accommodate a wide range of beam flanges:

- ZX6 – 150mm – 500mm*
- ZX8 – 200mm – 500mm* (0-12.5t)
- ZX8 – 300mm – 700mm* (12.5-25t)

*Special solutions available for beams outside these ranges

Few, if any, of the world's wire rope hoist manufacturers offer such an extensive range of single girder monorail hoists.

The advanced modular design of ZX Hoists provides a huge number of standard hoist combinations from a relatively small number of sub-assemblies



ZX08 Single Girder Hoist

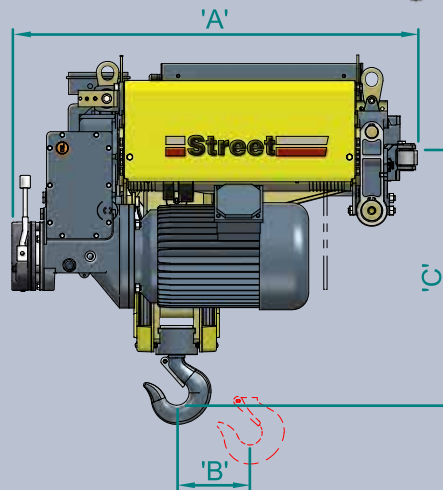

ZX06 HOIST SINGLE GIRDER

Hoist Model	S.W.L.		Duty	Lifting Height m.	Hoist		Rope		Transverse		Dimensions (mm.)					Weight Kg.	Wheel Dia.
	Tons	BS			FEM	2 Speeds (m/min)	Motor (Kw.)	Dia (mm.)	Reeving	Inverter (m/min)	Motor (Kw.)	A	B	C			
													*300	*400	*500		
ZX062-3FoNM5H052	2.5	M5	2m	13	10.3/3.4	7.8/2.6	8	2:1	0-2-20	0.25	978	213	631	752	871	329	100
ZX062-3FoLM5H052	2.5	M5	2m	20	10.3/3.4	7.8/2.6	8	2:1	0-2-20	0.25	1208	328	631	752	871	329	100
ZX062-3FoEM5H052	2.5	M5	2m	30	10.3/3.4	7.8/2.6	8	2:1	0-2-20	0.25	1553	492	631	752	871	410	100
ZX064-3FoNM7H031	2.5	M7	4m	6.5	5/1.8	3.7/1.2	8	4:1	0-2-20	0.25	978	106	585	706	825	350	100
ZX064-3FoLM7H031	2.5	M7	4m	10	5/1.8	3.7/1.2	8	4:1	0-2-20	0.25	1208	163	585	706	825	386	100
ZX064-3FoEM7H031	2.5	M7	4m	15	5/1.8	3.7/1.2	8	4:1	0-2-20	0.25	1553	245	585	706	825	439	100
ZX064-3FoNM7I041	3.2	M7	4m	6.5	5.3/1.8	4.7/1.6	8	4:1	0-2-20	0.25	978	106	585	706	825	350	100
ZX064-3FoLM7I041	3.2	M7	4m	10	5.3/1.8	4.7/1.6	8	4:1	0-2-20	0.25	1208	163	585	706	825	386	100
ZX064-3FoEM7I041	3.2	M7	4m	15	5.3/1.8	4.7/1.6	8	4:1	0-2-20	0.25	1553	245	585	706	825	439	100
ZX064-3FoNM5K052	5	M5	2m	6.5	5.2/1.8	7.8/2.6	8	4:1	0-2-20	0.25	978	106	585	706	825	350	100
ZX064-3FoLM5K052	5	M5	2m	10	5.2/1.8	7.8/2.6	8	4:1	0-2-20	0.25	1208	163	585	706	825	386	100
ZX064-3FoEM5K052	5	M5	2m	15	5.2/1.8	7.8/2.6	8	4:1	0-2-20	0.25	1553	245	585	706	825	439	100

**Remark : Excerpt from our product portfolio. Above are standard model, Special specification is available for buyer, Please contact Distributor.

der monorail hoist

capacity up to 25 tons

One of the many technical advantages which ensures the high efficiency and reliability of this range of single girder hoists is the use of direct drive travelling machinery with no open gears or wheel flanges.



ZX08 Standard Low Head Hoist

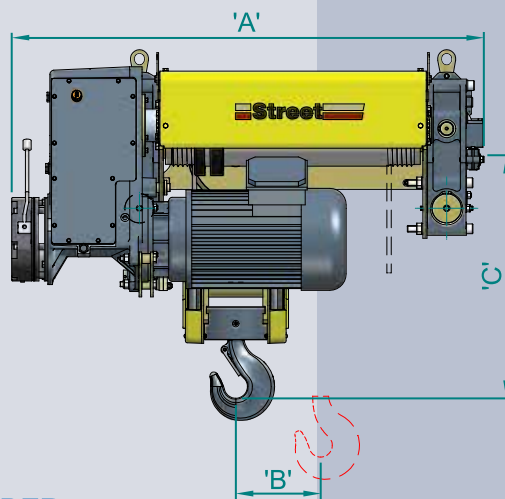

All low headroom models have improved headroom dimensions giving a lower roof height requirement.

The compact design of the hoists provides optimal top hook position, ideal for modern low profile buildings.

Side and end hook approaches have been designed to maximise factory floor coverage for a more productive work space.

ZX08 HOIST SINGLE GIRDER

Hoist Model	S.W.L.		Duty		Lifting Height m.	Hoist		Rope		Transverse		Dimensions (mm.)				Weight Kg.	Wheel Dia.
	Tons	BS	FEM	2 Speeds (m/min)		Motor (Kw)	Dia (mm.)	Reeving	Inverter (m/min)	Motor (Kw.)	A	B	C				
												*300	*400	*500			
ZX082-4SoNM6K074	5	M6	3m	16	8.7/2.2	11.2/2.8	13	2:1	0-2-20	0.37	1437	300	600	646	765	853	160
ZX082-4SoLM6K074	5	M6	3m	24	8.7/2.2	11.2/2.8	13	2:1	0-2-20	0.37	1697	430	600	646	765	930	160
ZX082-4SoEM6K074	5	M6	3m	40	8.7/2.2	11.2/2.8	13	2:1	0-2-20	0.37	2267	716	600	646	765	1098	160
ZX084-4FoNM7L074	6.3	M7	4m	8	5.4/1.3	11.2/2.8	13	4:1	0-2-20	0.37	1437	145	566	612	731	928	160
ZX084-4FoLM7L074	6.3	M7	4m	12	5.4/1.3	11.2/2.8	13	4:1	0-2-20	0.37	1697	215	566	612	731	1011	160
ZX084-4FoEM7L074	6.3	M7	4m	20	5.4/1.3	11.2/2.8	13	4:1	0-2-20	0.37	2267	358	566	612	731	1190	160
ZX084-4FoNM6N074	8	M6	3m	8	5.3/1.3	11.2/2.8	13	4:1	0-2-20	0.37	1437	145	566	612	731	928	160
ZX084-4FoLM6N074	8	M6	3m	12	5.3/1.3	11.2/2.8	13	4:1	0-2-20	0.37	1697	215	566	612	731	1011	160
ZX084-4FoEM6N074	8	M6	3m	20	5.3/1.3	11.2/2.8	13	4:1	0-2-20	0.37	2267	358	566	612	731	1190	160
ZX084-4FoNM5O088	10	M5	2m	8	5.5/1.4	13.0/3.2	13	4:1	0-2-20	0.37	1437	145	566	612	731	928	160
ZX084-4FoLM5O088	10	M5	2m	12	5.5/1.4	13.0/3.2	13	4:1	0-2-20	0.37	1697	215	566	612	731	1011	160
ZX084-4FoEM5O088	10	M5	2m	20	5.5/1.4	13.0/3.2	13	4:1	0-2-20	0.37	2267	358	566	612	731	1190	160
ZX084-4FoNM4P108	12.5	M4	1Am	8	5.6/1.4	19.2/4.8	13	4:1	0-2-20	0.37	1437	145	566	612	731	928	160
ZX084-4FoLM4P108	12.5	M4	1Am	12	5.6/1.4	19.2/4.8	13	4:1	0-2-20	0.37	1697	215	566	612	731	1011	160
ZX084-4FoEM4P108	12.5	M4	1Am	20	5.6/1.4	19.2/4.8	13	4:1	0-2-20	0.37	2267	358	566	612	731	1190	160
ZX086-4FoNM5R088	16	M5	2m	5.5	3.7/1	13.0/3.2	13	6:1	0-2-20	2x0.37	2205	100	1175	1175	1175	1867	160
ZX086-4FoLM5R088	16	M5	2m	8	3.7/1	13.0/3.2	13	6:1	0-2-20	2x0.37	2465	143	1175	1175	1175	2104	160
ZX086-4FoEM5R088	16	M5	2m	13	3.7/1	13.0/3.2	13	6:1	0-2-20	2x0.37	3035	240	1175	1175	1175	2328	160
ZX086-4EoNM4R108	16	M4	1Am	5.5	5.9/1.4	19.2/4.8	13	6:1	0-2-20	2x0.37	2205	100	1175	1175	1175	1867	160
ZX086-4EoLM4R108	16	M4	1Am	8	5.9/1.4	19.2/4.8	13	6:1	0-2-20	2x0.37	2465	143	1175	1175	1175	2104	160
ZX086-4EoEM4R108	16	M4	1Am	13	5.9/1.4	19.2/4.8	13	6:1	0-2-20	2x0.37	3035	240	1175	1175	1175	2328	160
ZX088-4EoLM5S108	20	M5	2m	6	4.4/1.1	19.2/4.8	13	8:1	0-2-20	2x0.37	2465	108	1282	1282	1282	2244	160
ZX088-4EoEM5S108	20	M5	2m	10	4.4/1.1	19.2/4.8	13	8:1	0-2-20	2x0.37	3305	180	1282	1282	1282	2453	160
ZX088-4XoLM5T108	25	M5	2m	6	3.3/0.9	19.2/4.8	13	8:1	0-2-20	2x0.37	2465	108	1282	1282	1282	2244	160
ZX088-4XoEM5T108	25	M5	2m	10	3.3/0.9	19.2/4.8	13	8:1	0-2-20	2x0.37	3305	180	1282	1282	1282	2453	160

**Remark : Excerpt from our product portfolio. Above are standard model, Special specification is available for buyer, Please contact Distributor.

double girder



ZX06 Double Girder Trolley

This new generation of hoists sets a benchmark for lifting and material handling in the 21st century.

The design concept of a single scrolled hoist drum provides the most efficient and cost effective solution for double girder and base mount applications in capacities up to 25 tonnes.

The unique low profile design of this range of double girder hoists is achieved by off-setting the rope diverter to allow a higher top hook position.

Multiple gearbox ratios, motor powers and hoist drum lengths provide standard ZX Hoist solutions for an exceptionally wide range of customer requirements.

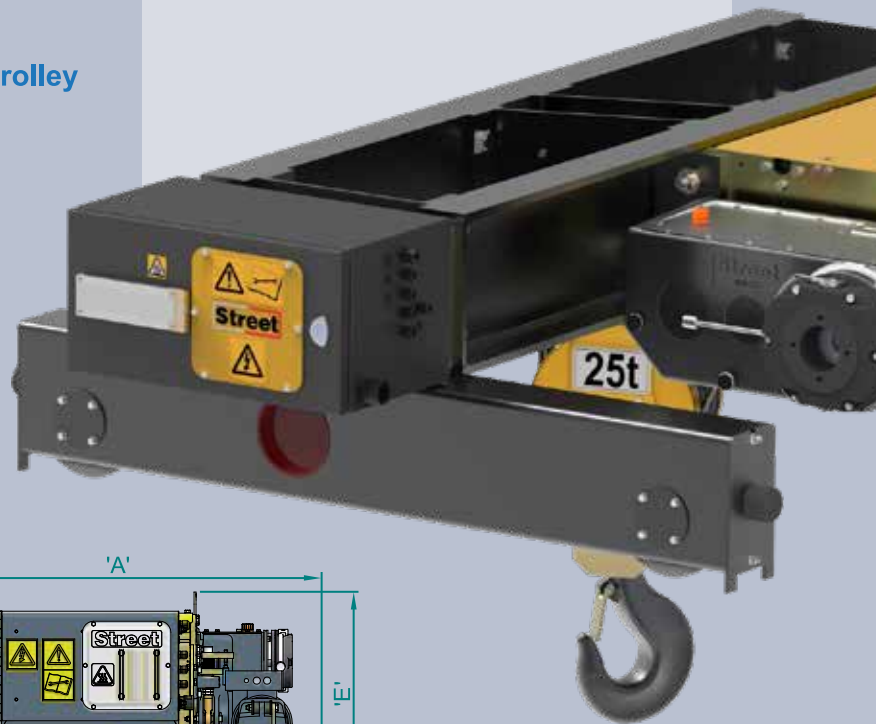

ZX08 Double Girder Trolley

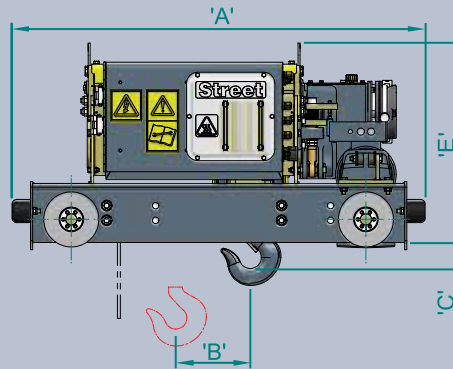
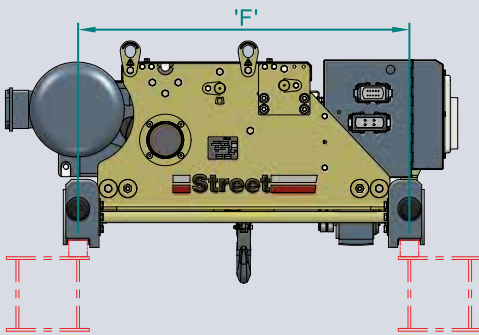

ZX06 HOIST DOUBLE GIRDER

Hoist Model	S.W.L.		Duty		Lifting Height m.	Hoist		Rope		Transverse		Dimensions (mm.)					Weight Kg.	Wheel Dia.
	Tons	BS	FEM	BS		FEM	2 Speeds (m/min)	Motor (Kw.)	Dia (mm.)	Reeving	Inverter (m/min)	Motor (Kw.)	A	B	C	E		
ZX062-3FoNM5H052	2.5	M5	2m	13	10.3 / 3.4	7.8/2.6	8	2:1	0-2-20	0.25	1122	213	104	541	900	423	125	
ZX062-3FoLM5H052	2.5	M5	2m	20	10.3 / 3.4	7.8/2.6	8	2:1	0-2-20	0.25	1352	328	104	541	900	477	125	
ZX062-3FoEM5H052	2.5	M5	2m	30	10.3 / 3.4	7.8/2.6	8	2:1	0-2-20	0.25	1697	492	104	541	900	566	125	
ZX064-3FoNM7H031	2.5	M7	4m	6.5	5/1.8	3.7/1.2	8	4:1	0-2-20	0.25	1122	106	71	541	900	446	125	
ZX064-3FoLM7H031	2.5	M7	4m	10	5/1.8	3.7/1.2	8	4:1	0-2-20	0.25	1352	163	71	541	900	502	125	
ZX064-3FoEM7H031	2.5	M7	4m	15	5/1.8	3.7/1.2	8	4:1	0-2-20	0.25	1697	245	71	541	900	596	125	
ZX064-3FoNM7I041	3.2	M7	4m	6.5	5.3/1.8	4.7/1.6	8	4:1	0-2-20	0.25	1122	106	71	541	900	446	125	
ZX064-3FoLM7I041	3.2	M7	4m	10	5.3/1.8	4.7/1.6	8	4:1	0-2-20	0.25	1352	163	71	541	900	502	125	
ZX064-3FoEM7I041	3.2	M7	4m	15	5.3/1.8	4.7/1.6	8	4:1	0-2-20	0.25	1697	245	71	541	900	596	125	
ZX064-3FoNM5K052	5	M5	2m	6.5	5.2/1.8	7.8/2.6	8	4:1	0-2-20	0.25	1122	106	71	541	900	446	125	
ZX064-3FoLM5K052	5	M5	2m	10	5.2/1.8	7.8/2.6	8	4:1	0-2-20	0.25	1352	163	71	541	900	502	125	
ZX064-3FoEM5K052	5	M5	2m	15	5.2/1.8	7.8/2.6	8	4:1	0-2-20	0.25	1697	245	71	541	900	596	125	

**Remark : Excerpt from our product portfolio. Above are standard model, Special specification is available for buyer, Please contact Distributor.

Order single rope hoist capacity up to 25 tons

Most hoist versions are available with the hoist drum parallel or perpendicular to the crane beams allowing side hook approaches to be optimised to best suit the application.

To ensure high performance and long-life, all travelling machinery incorporates direct drive technology with power transmission through a spline or shaft connection.



ZX08 Double Girder Trolley

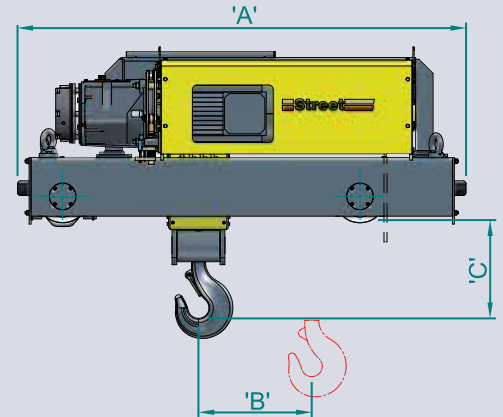
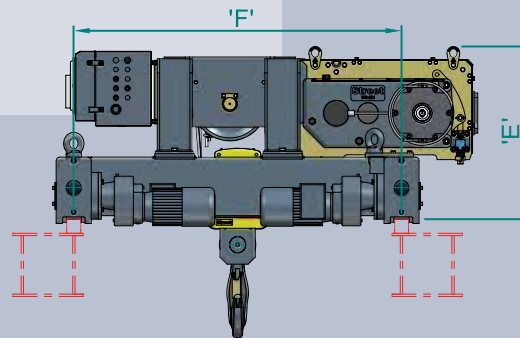

ZX08 HOIST DOUBLE GIRDER

Hoist Model	S.W.L.		Duty		Lifting Height m.	Hoist		Rope		Transverse		Dimensions (mm.)					Weight Kg.	Wheel Dia.
	Tons	BS	BS	EM		2 Speeds (m/min)	Motor (Kw.)	Dia (mm.)	Reeving	Inverter (m/min)	Motor (Kw.)	A	B	C	E	F		
ZX082-4SoNM6K074	5	M6	M6	3m	16	8.7/2.2	11.2/2.8	13	2:1	0-2-20	0.55	1552	300	295.5	679	1400	1002	160
ZX082-4SoLM6K074	5	M6	M6	3m	24	8.7/2.2	11.2/2.8	13	2:1	0-2-20	0.55	1782	430	295.5	679	1400	1104	160
ZX082-4SoEM6K074	5	M6	M6	3m	40	8.7/2.2	11.2/2.8	13	2:1	0-2-20	0.55	2352	716	295.5	679	1400	1329	160
ZX084-4FoNM7L074	6.3	M7	M7	4m	8	5.4/1.3	11.2/2.8	13	4:1	0-2-20	0.55	1552	145	260.5	679	1400	1078	160
ZX084-4FoLM7L074	6.3	M7	M7	4m	12	5.4/1.3	11.2/2.8	13	4:1	0-2-20	0.55	1782	215	260.5	679	1400	1185	160
ZX084-4FoEM7L074	6.3	M7	M7	4m	20	5.4/1.3	11.2/2.8	13	4:1	0-2-20	0.55	2352	358	260.5	679	1400	1419	160
ZX084-4FoNM6N074	8	M6	M6	3m	8	5.3/1.3	11.2/2.8	13	4:1	0-2-20	0.55	1552	145	260.5	679	1400	1078	160
ZX084-4FoLM6N074	8	M6	M6	3m	12	5.3/1.3	11.2/2.8	13	4:1	0-2-20	0.55	1782	215	260.5	679	1400	1185	160
ZX084-4FoEM6N074	8	M6	M6	3m	20	5.3/1.3	11.2/2.8	13	4:1	0-2-20	0.55	2352	358	260.5	679	1400	1419	160
ZX084-4FoNM5O088	10	M5	M5	2m	8	5.5/1.4	13.0/3.2	13	4:1	0-2-20	0.55	1552	145	260.5	679	1400	1078	160
ZX084-4FoLM5O088	10	M5	M5	2m	12	5.5/1.4	13.0/3.2	13	4:1	0-2-20	0.55	1782	215	260.5	679	1400	1185	160
ZX084-4FoEM5O088	10	M5	M5	2m	20	5.5/1.4	13.0/3.2	13	4:1	0-2-20	0.55	2352	358	260.5	679	1400	1419	160
ZX084-4FoNM4P108	12.5	M4	M4	1Am	8	5.6/1.4	19.2/4.8	13	4:1	0-2-20	0.55	1552	145	260.5	679	1400	1078	160
ZX084-4FoLM4P108	12.5	M4	M4	1Am	12	5.6/1.4	19.2/4.8	13	4:1	0-2-20	0.55	1782	215	260.5	679	1400	1185	160
ZX084-4FoEM4P108	12.5	M4	M4	1Am	20	5.6/1.4	19.2/4.8	13	4:1	0-2-20	0.55	2352	358	260.5	679	1400	1419	160
ZX086-4FoNM5R088	16	M5	M5	2m	5.5	3.7/1	13.0/3.2	13	6:1	0-2-20	2x0.37	1656	100	372	738	1400	1292	160
ZX086-4FoLM5R088	16	M5	M5	2m	8	3.7/1	13.0/3.2	13	6:1	0-2-20	2x0.37	1916	143	372	738	1400	1410	160
ZX086-4FoEM5R088	16	M5	M5	2m	13	3.7/1	13.0/3.2	13	6:1	0-2-20	2x0.37	2486	240	372	738	1400	1669	160
ZX086-4EoNM4R108	16	M4	M4	1Am	5.5	5.9/1.4	19.2/4.8	13	6:1	0-2-20	2x0.37	1656	100	372	738	1400	1292	160
ZX086-4EoLM4R108	16	M4	M4	1Am	8	5.9/1.4	19.2/4.8	13	6:1	0-2-20	2x0.37	1916	143	372	738	1400	1410	160
ZX086-4EoEM4R108	16	M4	M4	1Am	13	5.9/1.4	19.2/4.8	13	6:1	0-2-20	2x0.37	2486	240	372	738	1400	1669	160
ZX088-4EoLM5S108	20	M5	M5	2m	6	4.4/1.1	19.2/4.8	13	8:1	0-2-20	2x0.37	1916	108	421	738	1400	1496	200
ZX088-4EoEM5S108	20	M5	M5	2m	10	4.4/1.1	19.2/4.8	13	8:1	0-2-20	2x0.37	2486	180	421	738	1400	1753	200
ZX088-4XoLM5T108	25	M5	M5	2m	6	3.3/0.9	19.2/4.8	13	8:1	0-2-20	2x0.37	1916	108	421	738	1400	1496	200
ZX088-4XoEM5T108	25	M5	M5	2m	10	3.3/0.9	19.2/4.8	13	8:1	0-2-20	2x0.37	2486	180	421	738	1400	1753	200

**Remark : Excerpt from our product portfolio. Above are standard model, Special specification is available for buyer, Please contact Distributor.

ZX10

dou

single rope hoist capacity up to 32 tons

Zero lateral hook movement over the full lifting height results in equal trolley wheel loads. This, in-turn, allows the crane designer to optimise the dimensions and weight of the crane structure generally resulting in savings in the building structure or supporting steelwork

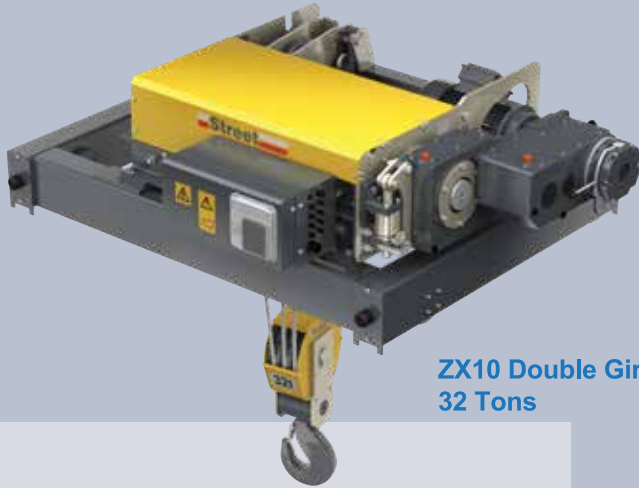

**ZX10 Double Girder Trolley
32 Tons**

These hoists sit at the top of the ZX range for the highest lifting capacities or for very heavy duty ratings.

Faster lifting speeds and greater lifting heights at lesser capacities are also available.

Key features include double scrolled hoist drum and genuine true vertical lift for enhanced safety and precision handling.

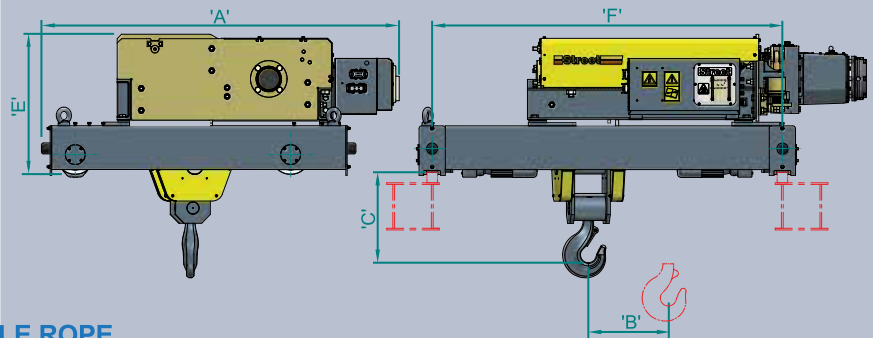
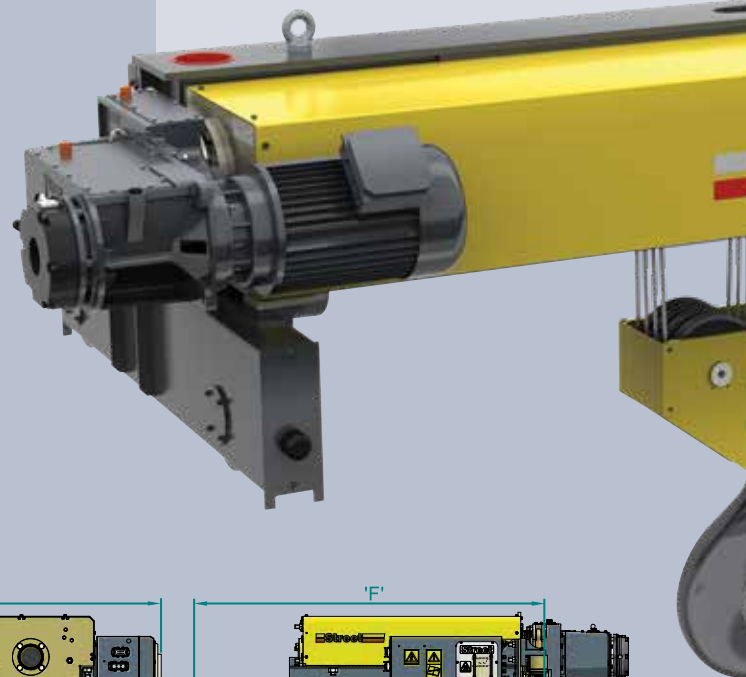

ZX10 SS HOIST SINGLE GIRDER AND SINGLE ROPE

Hoist Model	S.W.L.		Duty		Lifting Height m.	Hoist		Rope		Transverse		Dimensions (mm.)					Weight Kg.	Wheel Dia.
	Tons	BS	FEM	2 Speeds (m/min)		Motor (Kw.)	Dia (mm.)	Reeving	Inverter (m/min)	Motor (Kw.)	A	B	C	E	F			
ZX1004-4EaS8CM5J107-SS	20	M5	2m	10	4.1/1	19.2/4.8	18	4:1	0-2-20	2x0.37	2043	216	517	787	2000	1876	200	
ZX1004-4EaN8CM5J107-SS	20	M5	2m	15	4.1/1	19.2/4.8	18	4:1	0-2-20	2x0.37	2043	316	517	787	2600	2113	200	
ZX1004-4EaL8CM5J107-SS	20	M5	2m	21	4.1/1	19.2/4.8	18	4:1	0-2-20	2x0.37	2043	416	517	787	3200	2351	200	
ZX1004-4EaE8CM5J107-SS	20	M5	2m	23	4.1/1	19.2/4.8	18	4:1	0-2-20	2x0.37	2043	466	517	787	3200	2435	200	
ZX1004-4EaV8CM5J107-SS	20	M5	2m	29	4.1/1	19.2/4.8	18	4:1	0-2-20	2x0.37	2043	591	517	787	4000	2736	200	
ZX1006-4CaS8CM5K107-SS	25	M5	2m	7	3.3/0.8	19.2/4.8	18	6:1	0-2-20	2x0.37	2043	144	613	792	2000	1904	200	
ZX1006-4CaN8CM5K107-SS	25	M5	2m	10	3.3/0.8	19.2/4.8	18	6:1	0-2-20	2x0.37	2043	210	613	792	2600	2143	200	
ZX1006-4CaL8CM5K107-SS	25	M5	2m	14	3.3/0.8	19.2/4.8	18	6:1	0-2-20	2x0.37	2043	277	613	792	3200	2383	200	
ZX1006-4CaE8CM5K107-SS	25	M5	2m	15	3.3/0.8	19.2/4.8	18	6:1	0-2-20	2x0.37	2043	310	613	792	3200	2469	200	
ZX1006-4CaV8CM5K107-SS	25	M5	2m	19	3.3/0.8	19.2/4.8	18	6:1	0-2-20	2x0.37	2043	394	613	792	4000	2771	200	
ZX1006-4EaS8CM5M107-SS	32	M5	2m	7	2.8/0.7	19.2/4.8	18	6:1	0-2-20	2x0.37	2043	144	613	792	2000	1904	200	
ZX1006-4EaN8CM5M107-SS	32	M5	2m	10	2.8/0.7	19.2/4.8	18	6:1	0-2-20	2x0.37	2043	210	613	792	2600	2143	200	
ZX1006-4EaL8CM5M107-SS	32	M5	2m	14	2.8/0.7	19.2/4.8	18	6:1	0-2-20	2x0.37	2043	277	613	792	3200	2383	200	
ZX1006-4EaE8CM5M107-SS	32	M5	2m	15	2.8/0.7	19.2/4.8	18	6:1	0-2-20	2x0.37	2043	310	613	792	3200	2469	200	
ZX1006-4EaV8CM5M107-SS	32	M5	2m	19	2.8/0.7	19.2/4.8	18	6:1	0-2-20	2x0.37	2043	394	613	792	4000	2771	200	

**Remark : Excerpt from our product portfolio. Above are standard model, Special specification is available for buyer, Please contact Distributor.

ble girder

twin rope hoist capacity up to 80 tons

This range of hoists is available in a robust heavy duty open winch format with drum flanges instead of rope guides.

As an optional safety enhancement, true vertical lift models of ZX hoists are available with separate ropes in the left and right hand scrolls with a compensating bar rather than a sheave.



ZX10 Double Girder Trolley
80 Tons



ZX10 Double Girder Trolley
40 Tons

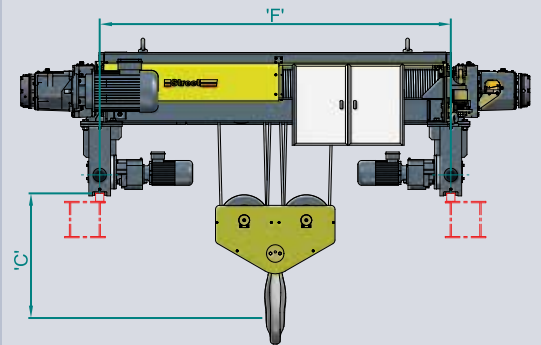
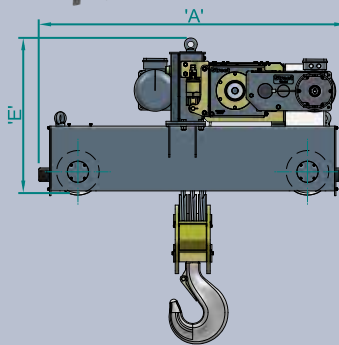

ZX10 ST HOIST SINGLE GEARBOX AND TWIN ROPE

Hoist Model	S.W.L.		Duty		Lifting Height m.	Hoist		Rope		Transverse		Dimensions (mm.)					Weight Kg.	Wheel Dia.
	Tons	BS	FEM	2 Speeds (m/min)		Motor (Kw.)	Dia (mm.)	Reeving	Inverter (m/min)	Motor (Kw.)	A	B	C	E	F			
ZX1008-4CoN3AM5I108-ST	16	M5	2m	11	3.7/0.9	19.2/4.8	13	8:2	0-2-20	2x0.37	2086	-	906	886	2000	2016	200	
ZX1008-4CoL3AM5I108-ST	16	M5	2m	15	3.7/0.9	19.2/4.8	13	8:2	0-2-20	2x0.37	2086	-	920	886	2600	2277	200	
ZX1008-4CoV3AM5I108-ST	16	M5	2m	22	3.7/0.9	19.2/4.8	13	8:2	0-2-20	2x0.37	2086	-	946.5	886	3600	2682	200	
ZX1008-4CoN3AM5J108-ST	20	M5	2m	11	3.7/0.9	19.2/4.8	13	8:2	0-2-20	2x0.37	2086	-	906	886	2000	2016	200	
ZX1008-4CoL3AM5J108-ST	20	M5	2m	15	3.7/0.9	19.2/4.8	13	8:2	0-2-20	2x0.37	2086	-	920	886	2600	2277	200	
ZX1008-4CoV3AM5J108-ST	20	M5	2m	22	3.7/0.9	19.2/4.8	13	8:2	0-2-20	2x0.37	2086	-	946.5	886	3600	2682	200	
ZX1008-4EaN3AM5K107-ST	25	M5	2m	11	3.1/0.8	19.2/4.8	13	8:2	0-2-20	2x0.37	2086	-	906	886	2000	2016	200	
ZX1008-4EoL3AM5K107-ST	25	M5	2m	15	3.1/0.8	19.2/4.8	13	8:2	0-2-20	2x0.37	2086	-	920	886	2600	2277	200	
ZX1008-4EoV3AM5K107-ST	25	M5	2m	22	3.1/0.8	19.2/4.8	13	8:2	0-2-20	2x0.37	2086	-	946.5	886	3600	2682	200	
ZX1012-4CaN3AM5M107-ST	32	M5	2m	7	2.5/0.7	19.2/4.8	13	12:2	0-2-20	2x0.37	2086	-	810	990	2000	2175	250	
ZX1012-4CaL3AM5M107-ST	32	M5	2m	10	2.5/0.7	19.2/4.8	13	12:2	0-2-20	2x0.37	2086	-	810	990	2600	2446	250	
ZX1012-4CaV3AM5M107-ST	32	M5	2m	14	2.5/0.7	19.2/4.8	13	12:2	0-2-20	2x0.37	2086	-	810	990	3600	2950	250	

ZX10 DT HOIST SINGLE GEARBOX AND TWIN ROPE

Hoist Model	S.W.L.		Duty		Lifting Height m.	Hoist		Rope		Transverse		Dimensions (mm.)					Weight Kg.	Wheel Dia.
	Tons	BS	FEM	2 Speeds (m/min)		Motor (Kw.)	Dia (mm.)	Reeving	Inverter (m/min)	Motor (Kw.)	A	B	C	E	F			
ZX1012-4CaN6DM5O107-DT	40	M5	2m	7	3.3/0.8	2x19.2/4.8	16	12:2	0-2-20	2x0.55	2280	-	965.5	1117	2000	3484	315	
ZX1012-4CaL6DM5O107-DT	40	M5	2m	10	3.3/0.8	2x19.2/4.8	16	12:2	0-2-20	2x0.55	2280	-	965.5	1149	2600	4152	315	
ZX1012-4CoV6DM5O107-DT	40	M5	2m	15	3.3/0.8	2x19.2/4.8	16	12:2	0-2-20	2x0.55	2280	-	965.5	1149	3600	4347	315	
ZX1012-4CaN6DM4Q107-DT	50	M4	1Am	7	3.3/0.8	2x19.2/4.8	16	12:2	0-2-20	2x0.55	2280	-	965.5	1117	2000	3484	315	
ZX1012-4CaL6DM4Q107-DT	50	M4	1Am	10	3.3/0.8	2x19.2/4.8	16	12:2	0-2-20	2x0.55	2280	-	965.5	1149	2600	4152	315	
ZX1012-4CaV6DM4Q107-DT	50	M4	1Am	15	3.3/0.8	2x19.2/4.8	16	12:2	0-2-20	2x0.55	2280	-	965.5	1149	2600	4347	315	

**Remark : Excerpt from our product portfolio. Above are standard model, Special specification is available for buyer, Please contact Distributor.

ZX HOIST: optional features/equipment.

- SC Smartdrive on traverse motions minimises load swing.
- Fast and extra fast hoist speeds for shorter handling times.
- 10:1 hoist creep speed for the most precise handling.
- One step traverse limit switches (slowdown or stop).
- Two step traverse limit switches (slowdown and stop).
- Second hoist brake mounted on hoist motor.
- Standby heaters in hoist and trolley motor.
- Load Indication Display.
- Load summation between two hoists.
- Visual or audible overload warning
- Frequency inverter on hoist motor.
- Non-standard traverse speeds.
- Push-button pendant on hoist.
- Standby heaters in control panel.
- Special voltages.
- Overspeed switch applies the hoist brake if the gearbox shaft is running more than 10% over normal speed.

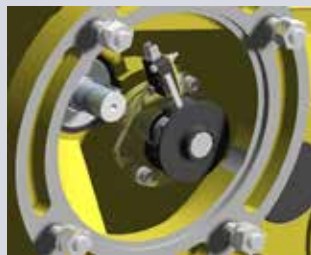

SC Smartdrive Technology.

The New ZX hoist incorporates **SC SMARTDRIVE, the latest, most advanced traverse speed control technology to give the superior performance you might expect from a world leader.**

ZX beats the competition by employing a full frequency inverter and current vector control for minimum load swing and easy, more accurate load positioning for greater safety and productivity.



- SC SMARTDRIVE is based on the latest inverter technology utilising dual CPU control and S-Ramp profiles on travel drives, to ensure smooth acceleration and controlled stopping with minimised load swing and increased efficiency and safety.
- Sensorless Current Vector method of motor control out-performs the Voltage Frequency method used by some competitors with respect to starting torque, speed holding and consistent slow speed performance.
- The SC SMARTDRIVE Inverter includes an LED status display to access a series of diagnostic and condition monitoring data, including Safe Working Period calculation.
- Mechanically more robust inverter unit with increased vibration resistance (up to 0.65g at 20 to 50 Hz).
- Plug-in Control Terminal Board with memory is another significant advantage and another uncommon feature on standard cranes and hoists. It provides for a simple change in the unlikely event the inverter fails with no need for any re-programming tools.
- Inverter is CE UL cUL and TUV approved and is suitable for environments with Relative Humidity of 95% (none condensing). It has a broad input range of 380 - 480 Volts -15% +10%.
- SC SMARTDRIVE Standard programming is for 2 speeds with standard smooth acceleration and deceleration ramps but the inverters are fully programmable for different speeds and accelerations, multiple speeds ramp and hold or infinitely variable between full speed and 10% of full speed.



10 GOOD REASONS to buy a Street ZX Hoist

We invite you to compare Street ZX Hoist technology with any on the globe

1. Unique hoist design with braked gearbox which provides significantly enhanced load security, reliability and maintainability compared to braked motor hoists

- When the operator applies the hoist brake it will hold the load even if the hoist motor is removed or if the hoist motor coupling, motor connection or motor shaft were to fail.
- Lower operating temperature in the hoist motor because heat generated by the hoist brake does not soak into the host motor.
- Greatly improved hoist brake accessibility.

2. No external hoist gears.

- Automotive quality hoist gearbox containing hardened and precision ground helical gears all of which are submerged in oil.
- Longer hoist gear life compared to hoists with external gears.
- Significantly reduced risk of hoist gear lubrication failure.

3. No external trolley gears.

- Direct drive hoist trolley (single and double girder) with hardened and precision ground helical gears all of which are submerged in oil.
- Longer trolley gear life compared to those with external gears cut into the trolley wheel flange.
- Significantly reduced risk of trolley gear lubrication failure.

4. Long life guide rollers on single beam trolley eliminate wheel flange wear.

- Guide rollers remove the need for wheel flanges which are a big wear item on competitor hoists.
- Crane beam flange wear is also eliminated.
- The use of guide rollers and flangeless wheels also reduces rolling resistance and improves trolley control and stability.

5. Reaction roller eliminates the need for a hoist counterweight on single beam cranes.

- Reduces hoist and crane weight.
- Improves traction and control.

6. Choice of advanced control system.

- Two speed motor drive with soft starting inertia flywheel plus auto-timer timer control through slow to fast which gives extremely fine control without the use of electronics.
- or
- SC Smartdrive sensorless current vector control system with LED status diagnostics, condition monitoring and removable memory board. Speeds, acceleration and deceleration are fully programmable.



7. Heavy duty double band rope guide provides improved reliability.

- Inner band holds the rope tight to the drum to prevent rope back up and damage if the operator causes 'slack rope.'
- Outer band guides the rope perfectly into the drum scroll.

8. Patented safe load cut-out device prevents overloading.

- The device is situated in the hoist gearbox torque arm and therefore measures all the load the hoist mechanism is transmitting (not just the load in one or two ropes).
- Actuated directly by the load and does not rely on measuring electrical current.

9. Adjustable DC disc brakes on travel and traverse motions for controlled braking.

- Full range torque adjustment allows stopping distances to be adjusted to suit the application.

10. Lifetime cost of ownership is the intelligent comparison and ZX technology is designed to give reduced service and maintenance costs.

- ZX open plan hoist design reduces the time and costs of maintenance and service tasks because they can be executed without dismantling the hoist.
- External hoist brake, motor and gearbox for easy access.
- Hoist gear inspection cover.
- Motor coupling inspection facility.
- Non-captive proprietary switchgear.
- Overheating protection of the hoist motor.
- Hours in service meter.
- Protection against phase failure and incorrect phase sequencing.
- Under voltage and over current protection.

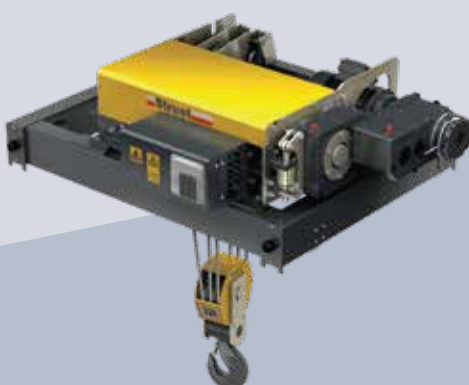



www.titancrane.co.th

Distributed By :

TITAN[®]



TITAN CRANE CO.,LTD.

1/19 Moo 1 Phimpha, Bangpakong, Chachoengsao 24130 Thailand.

Tel. 038 989 369-72 Fax. 038 989 368

E-mail : titancrane.info@gmail.com