

KENDRION

INTORQ

POWERED BY KENDRION

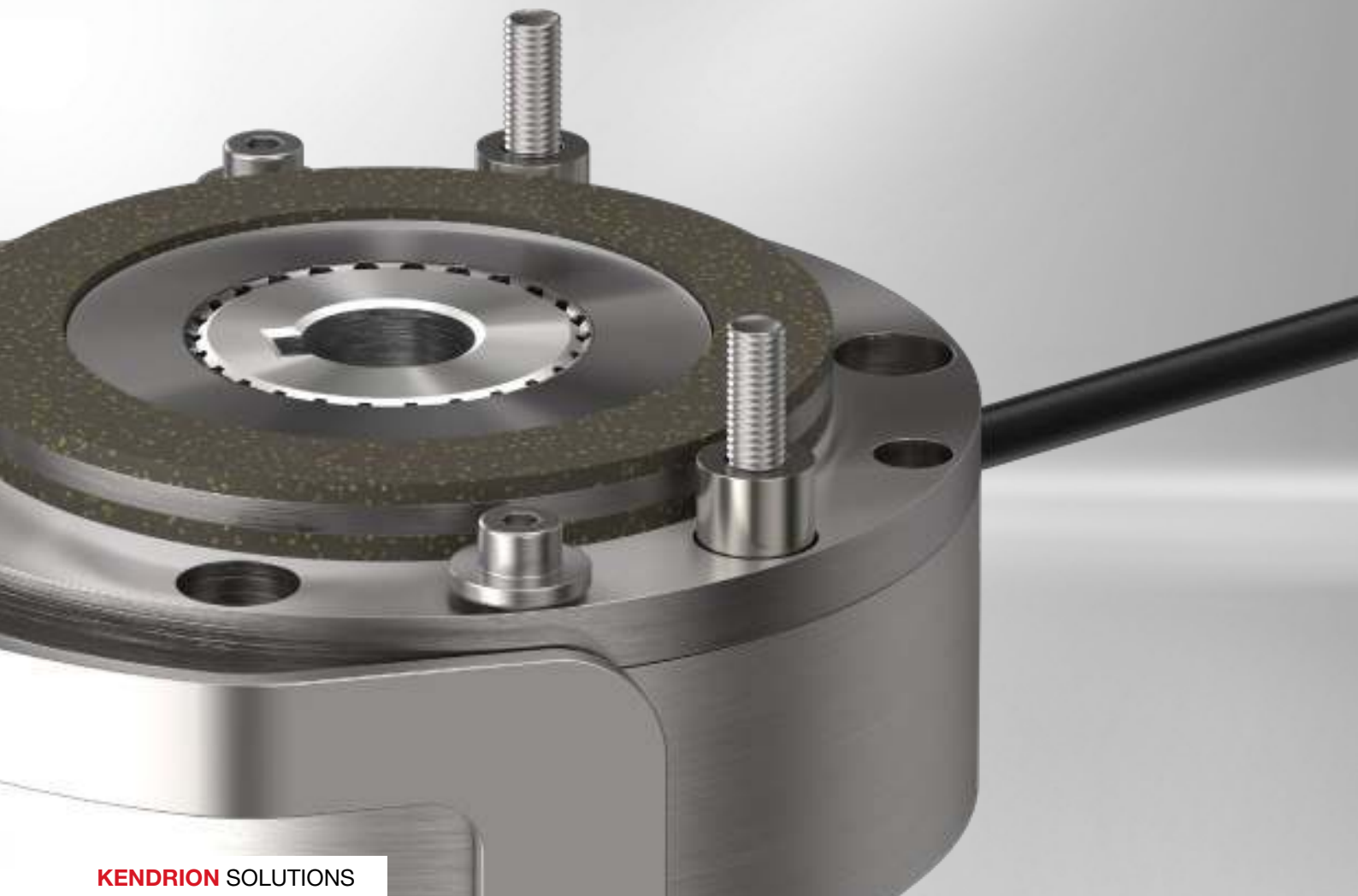

KENDRION SOLUTIONS

INTORQ BFK457

Spring-applied brake – 100% reliability
Compact and easily fitted

PRECISION. SAFETY. MOTION.

Our brakes – perfect for your safe application

KENDRION Industrial Brakes – stands for smart innovation and excellent service, which we consistently apply for the benefit of our customers:

Strong know-how

Our specialists develop the leading-edge permanent magnet and spring-applied brakes. With INTORQ as a new member of KENDRION, we have once again consistently expanded our range of spring-applied brakes and clutches for you. This way, we can find the right solution for any of your requirements.



Complete product portfolio

Electromagnetic brakes and clutches as well as perfectly matched accessories: with us you will find an exceptionally large selection of quickly available off-the-shelf products that can be put together in a modular system and the best expertise for customer-specific solutions.

Dynamic innovative power

More than 50 specialists working in agile teams in our research and development worldwide are creating convincing product solutions for tomorrow.

Excellent market knowledge

We are very familiar with our focus markets – thanks to extensive experience and research, but also thanks to long-term customer relationships built on partnership and eye-to-eye cooperation.

International power

Committed and competent employees, production sites in Germany, United States, India and China as well as a large number of certified sales partners all over the world make us a strong partner for you!

The INTORQ BFK457

On the point

- Fail-Safe spring applied-brake
- Operating brake and holding brake with emergency stop function
- Easy mounting due to integrated fixing screws
- Project solutions quickly implementable
- CSA-certified



Suitable for the use of:



Conveyors



Industrial trucks



Hoists

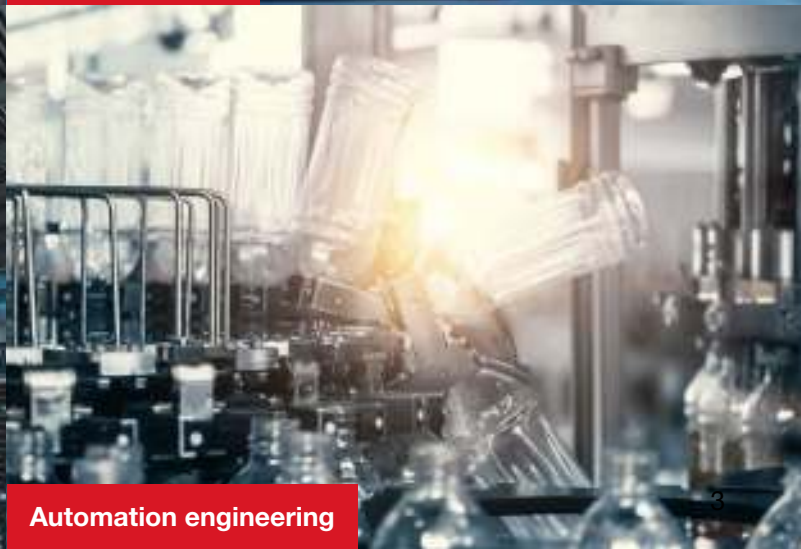

Automation engineering

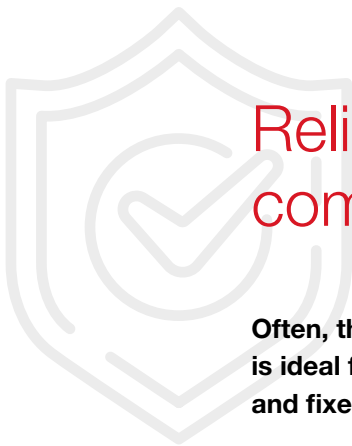

Reliable spring-applied brake – compact & easily fitted

Often, the brake is only required to perform its basic function. The BFK457 is ideal for these situations. The speed of fitting with integral fixing screws and fixed air gap make this spring-applied brake even more attractive.

The standard INTORQ BFK457 is offered with few additional options. The design as a turned part facilitates specific adaptations to achieve project solutions. You can rely on tried-and-tested components of the Intorq modular system for friction systems to meet the high quality standards.

The INTORQ BFK457, labeled with the CE mark and CSA certified, is suitable for all markets worldwide. As with the BFK458, BFK470, and BFK557 series, the bolt circle, the available hub diameters, and the number of mounting screws are always identical so that interchangeability between the individual series is ensured.

The compact brake unit, with a fixed air gap, allows for a simple and cost-effective installation. Moreover, there are no maintenance costs when used as a holding brake. For optimal control of the brakes, Kendrion offers the corresponding rectifiers depending on the requirements. Contact us!

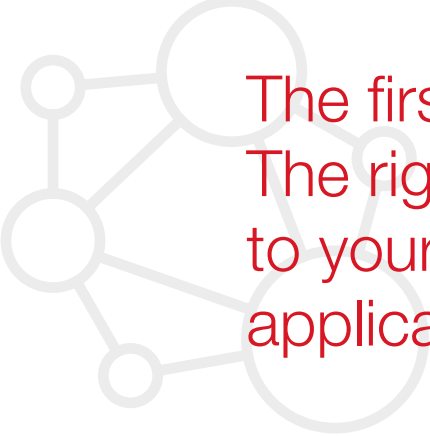

The first choice for projects:
The right brake, customized
to your specific
application



Technical highlights

- Compact one-piece design
- Fast and easy installation
- No adjustments
- Design-in platform for customized solutions

Technical data

Design types	Compact, basic, double brake
Standard rated voltages	24 V, 205 V
Protection class	IP00 – IP55
Thermal class	F (155°C)
Ambient temperature	-20°C to 40°C
Rated torques	4 to 125 Nm
Duty time	100% ED
Nominal backlash	1°
Options	Friction plate, flange, hand release, seal ring, customizations
Note	Please read the general information on data sheets and the corresponding operating instructions. Design subject to change without notice.



Brake size	Rated torques for operating brakes @ 100 [min ⁻¹]	Rated torques for holding brakes ¹⁾ @ 100 [min ⁻¹]	Maximum speed n _{max} [min ⁻¹]	Shifting work for single shift W _{max} [J]	Number of emergency stops Z _{ges} [-]	Friction work up to maintenance for operating brakes with WR coating Q _{BW} [MJ]
06	4	6	6000	3000	500	35
08	8	12	5000	7500	500	65
10	16	23	4000	12000	500	105
12	32	46	3600	24000	500	210
14	60	95	3600	30000	500	230
16	80	125	3600	36000	500	400

¹⁾ The use of holding brakes as operating brakes is possible but requires the use of over-excitation.



You will find the right design for your application in our product finder!



Dimensions

Brake size	b	d ^{d7 1)} spec.	d ^{d7 2)} standard	d1	d2	d3	d4	d5	d6	d7	d11	da	di
06	90	10	11/12/14/15	3xM4	72	84	31	31	84	M4x30	8	60	40
08	108	10	11/12/14/15/20	3xM5	90	102	42	41.5	102	M5x35	8	76.5	56.1
10	137	10	15/20	3xM6	112	130	44	44	130	M5x40	10	95	66.1
12	157	14	20/25	3xM6	132	150	52	52	150	M5x45	10	115	70.1
14	174	14	20/25/30	3xM8	145	165	55	60	165	M6x55	12	124	80.1
16	203	15	25/30/35/38 ³⁾	3xM8	170	190	70	70	190	M6x60	12	149	104.1

¹⁾ Pilot bored without keyway

²⁾ Standard keyway in accordance with DIN 6885/1-P9

³⁾ Ø 38 mm, keyway in accordance with DIN 6885/3-P9

Compact design

fully assembled with rotor and flange

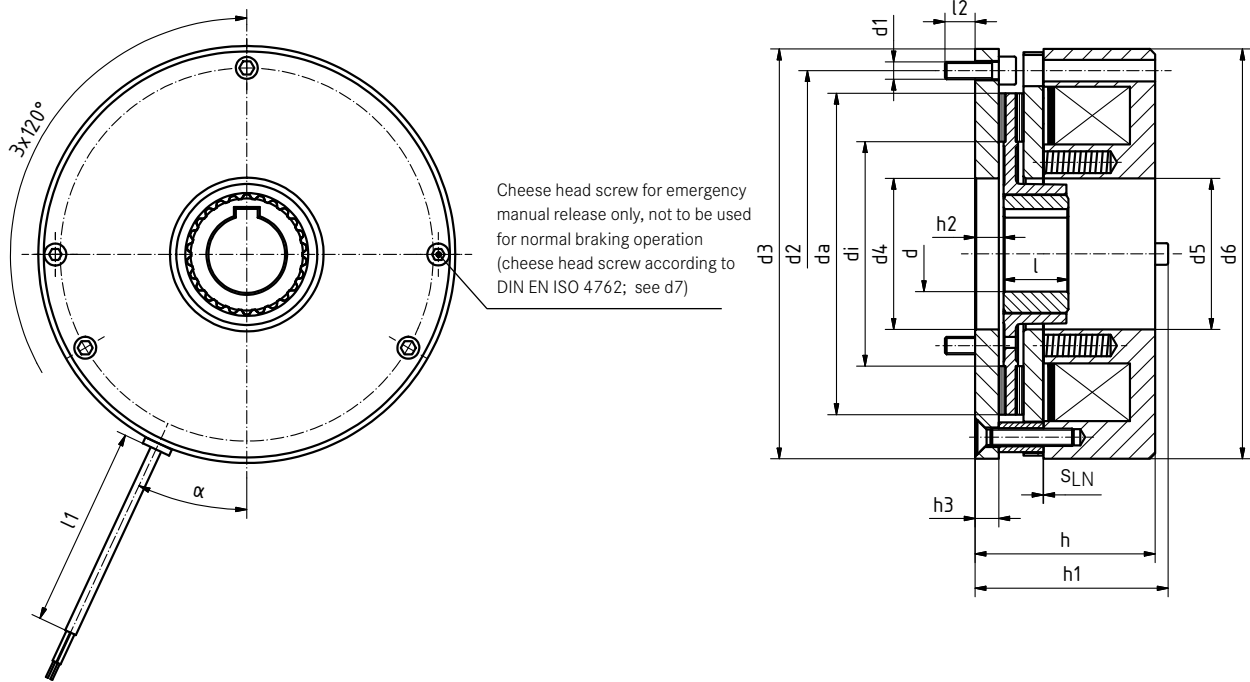

Dimensions

Brake size	h	h1	h2	h3	h4	h5	h6	h7	l	l1	l2 ⁴⁾	s _{LN}	α	β	m [kg]
06	41.3	45.3	7	6	15.8	107	49	49.7	18	400	6	0.2	25°	10°	1.1
08	49.8	54.8	8.5	7	16.3	118	59	57.1	20	400	9	0.2	25°	10°	1.9
10	56.4	61.5	10	8	27.4	142	74	65.2	20	400	12	0.3	25°	10°	3.8
12	62.4	67.4	10	8	29.4	162	84	71.2	25	400	12	0.3	25°	10°	5.7
14	77.3	83.3	13	11	33	201	94	89	30	400	14	0.3	25°	10°	8.6
16	83.5	89.5	13.3	11	37.5	250	108	99.9	30	600	14	0.3	25°	10°	12

⁴⁾ Please contact the manufacturer if a different mounting surface made from steel is used.

Compact design with hand release

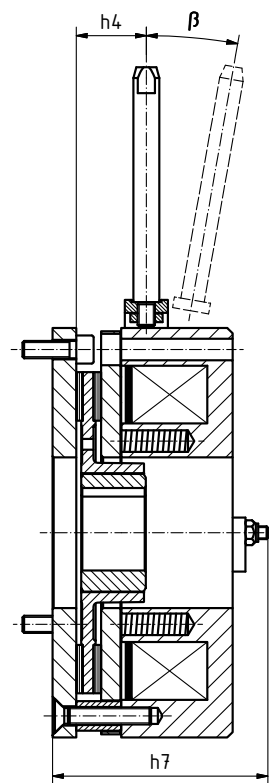
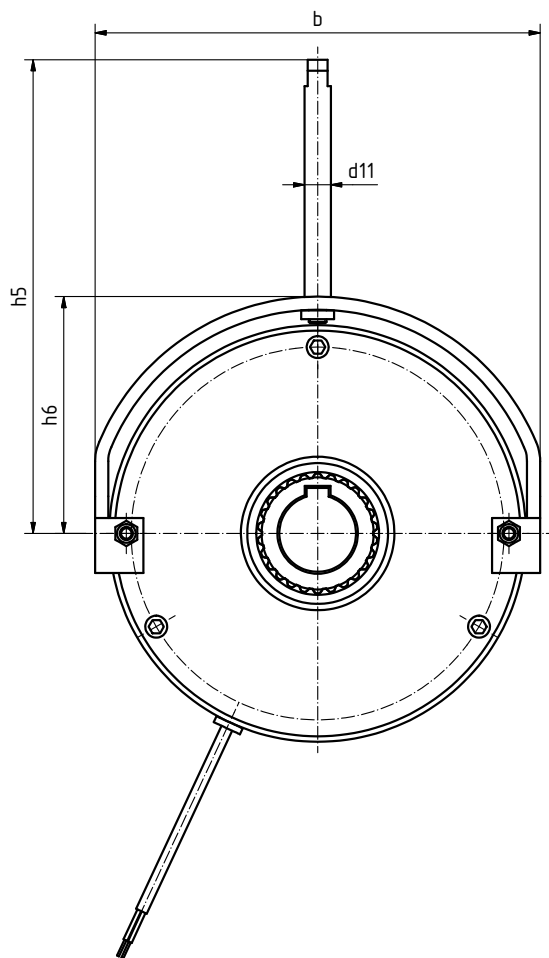

Dimensions Double spring-applied brake

Brake size	b	d ^{J7 1)} spec.	d ^{H7 2)} standard	d1	d2	d5	d6	d11	da	di	h	h1
06	90	10	11/12/14/15	3xM4	72	31	84	8	60	40	35.3	75.5
08	108	10	11/12/14/15/20	3xM5	90	41.5	102	8	77	57	42.8	90.5
10	137	10	15/20	3xM6	112	44	130	10	95	66	48.4	102.9
12	157	14	20/25	3xM6	132	52	150	10	115	70	54.4	114.7
14	174	14	20/25/30	3xM8	145	60	165	12	124	80	66.3	140.5
16	203	15	25/30/35/38 ³⁾	3xM8	170	70	190	12	149	104	72.5	153.1

Brake size	h2	h3	h5	h6	h8	h9	l	l1	l2 ⁴⁾	s _{LN}	α	m [kg]
06	1	70.6	109	54	13	44	18	400	6	0.2	25°	1.9
08	1.5	85.6	121.7	62	12.7	63.3	20	400	9	0.2	25°	3.2
10	2	96.8	147	84	16	70	20	400	11	0.3	25°	6.4
12	2	108.8	166	93	18.3	78.4	25	400	11	0.3	25°	9.8
14	2	132.6	186	106	22	91.5	30	400	14	0.3	25°	14.8
16	2.25	145	230	120.5	24.5	100	30	600	14	0.3	25°	21.0

1) Pilot bored without keyway

2) Standard keyway in accordance with DIN 6885/1-P9

3) Ø 38 mm, keyway in accordance with DIN 6885/3-P9

4) Please contact the manufacturer if a different mounting surface made from steel is used.

Low-noise design < 50 dbA

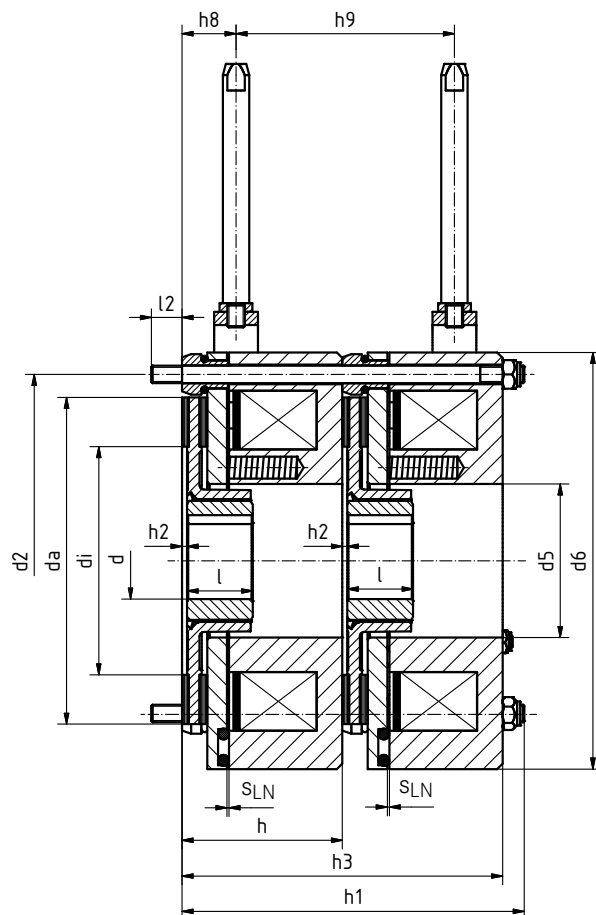
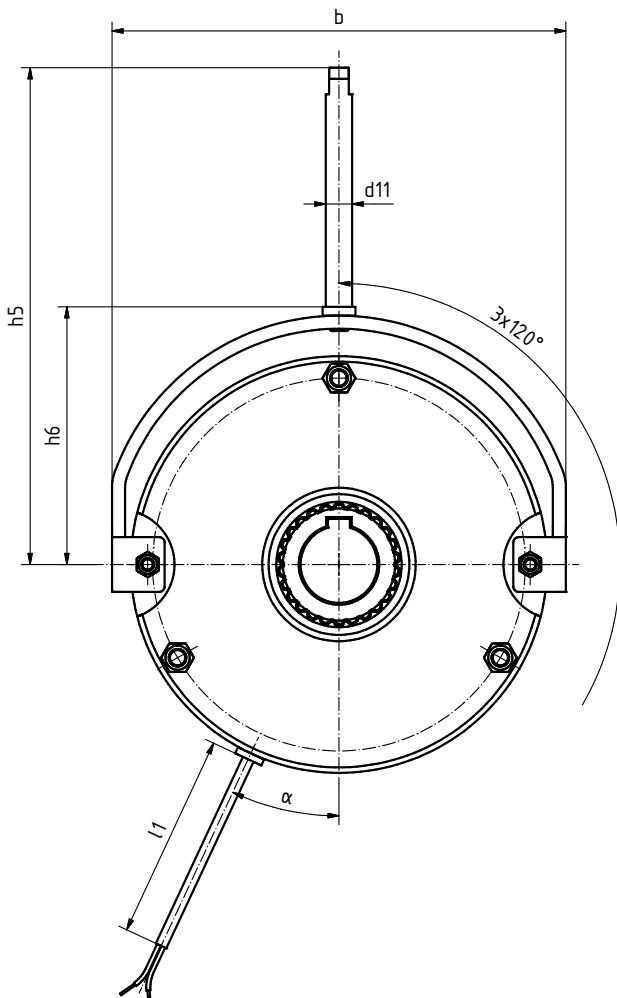

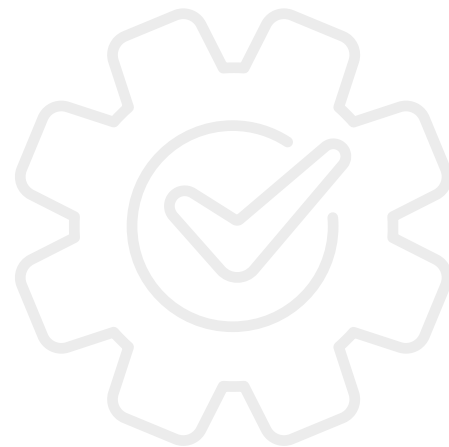

For an overview of the many standard options available, we offer you a choice of combinations. All features are available at short notice and have been extensively tested.

Design

- Version** Operating brake – Low rated torque
 Holding brake – Maximum rated torque
- Brake size** 06 08 10 12 14 16
- Voltage** 24 V 42 V (ab BG14) 205 V Other voltages customer-specific available
- Rotor** Standard Aluminium Other rotors customer-specific available
- Designs** Basic Compact Double brake

Options

- Hub** For bore diameter, see dimensions
- Hand release** Mounted (customer-specific available)
- Counter friction face** Friction plate Flange
- Sealing** Seal (customer-specific available)

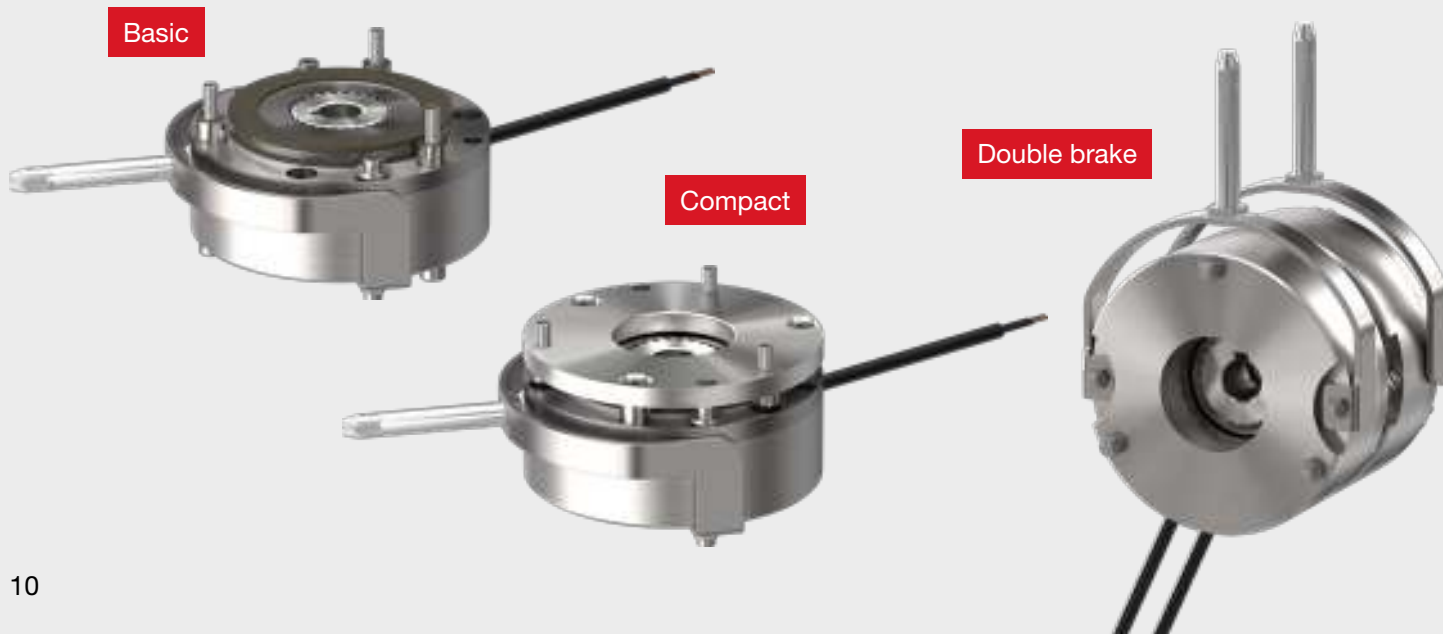

Customized solutions – tailored exactly to your needs

Automation solutions have become an indispensable part of industry and everyday life. In this context, it is often the brakes that ensure safety: They hold loads and brake reliably in an emergency.

Just as automation continues to evolve, brakes must also face higher demands – forward-looking products are in demand. At the same time, quality and safety must be unconditionally guaranteed. This is a challenge that Kendrion Industrial Brakes meets with passion and care.



When it comes to developing customer-specific solutions, we have three aces up our sleeves:

- With our **new agile organization**, we respond much faster to customer requests.
- Our **modularly developed products** enable new configurations without complete redevelopment.
- The **global structure of our organization** bundles competencies and ensures valuable knowledge transfer.

This makes us a competent and reliable partner for our customers – starting with industry-savvy consulting, through product development with practical experience, to uncompromising quality assurance.



We will find the
solution that suits
you best!



KENDRION

Kendrion INTORQ GmbH

Wülmser Weg 5
31855 Aerzen
Germany

T +49 5154 70534-222
sales-aerzen-ib@kendrion.com

INTORQ US INC.

106 Northpoint Parkway
Acworth, GA30102
USA

T +1 678 236 0555
F +1 678 309 1157
info-atlanta-ib@kendrion.com

Kendrion (China) Co., Ltd.

No.10 Huipu Road,
Suzhou Industrial Park
Suzhou City
Jiangsu Province
China

T +86 21 20363 810
F +86 21 20363 805
sales-china@kendrion.com

INTORQ India Pvt. Ltd.

Plot No E-2/7
Chakan Industrial Area, Phase 3
Kharabwadi, Taluka – Khed
Pune, 410501, Maharashtra
India

T +91 21 3562 5500
info-pune-ib@kendrion.com

www.kendrion.com

© KENDRION 02.11.2022

PRECISION. SAFETY. MOTION.