



“TITAN” CONDUCTOR SYSTEMS

3 Pole 75 Amp, 100 Amp

4 Pole 75 Amp, 100 Amp



TITAN[®]
SERVICE
TITAN SERVICE CO., LTD.

3 Pole Titan Conductor Bar

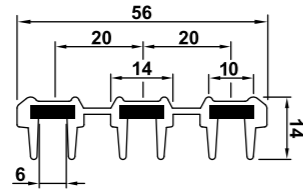

| 3P. "TITAN" Conductor Bar | | | |
|---------------------------|-----------|------|--------------|
| Order No. | Intensity | long | Weight (Kg.) |
| 1-032-0001 | 75A | 1 M. | 0.82 |
| 1-032-0002 | 100A | 1 M. | 1.07 |

Material : PVC., Copper

4 Pole Titan Conductor Bar

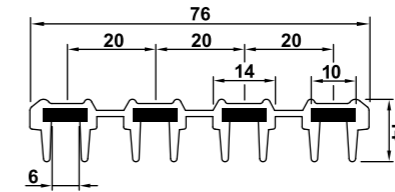

| 4P. "TITAN" Conductor Bar | | | |
|---------------------------|-----------|------|--------------|
| Order No. | Intensity | Long | Weight (Kg.) |
| 1-032-0007 | 75A | 1 M. | 1.00 |
| 1-032-0008 | 100A | 1 M. | 1.20 |

Material : PVC., Copper

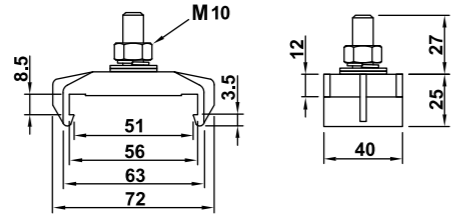

| 3P. Hanger Clamp | | |
|------------------|---------------|--------------|
| Order No. | References | Weight (Kg.) |
| 1-032-0003 | 75Amp, 100Amp | 0.07 |

Material : PVC., Copper

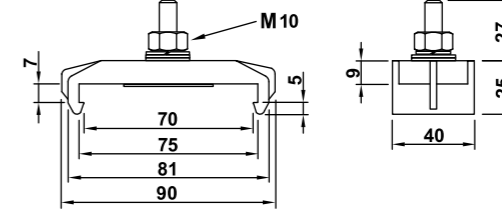

| 4P. Hanger Clamp | | |
|------------------|------------|--------------|
| Order No. | References | Weight (Kg.) |
| 1-032-0009 | 75A, 100A | 0.075 |

Material : PVC., Steel

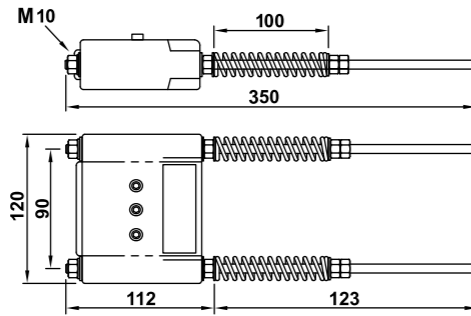

| 3P. End Tension And Power Feed In | | |
|-----------------------------------|------------|--------------|
| Order No. | References | Weight (Kg.) |
| 1-032-0004 | 75A, 100A | 1.38 |

Material : PVC., Steel, Copper

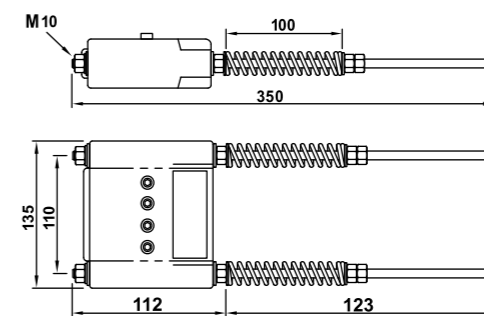

| 4P. End Tension And Power Feed In | | |
|-----------------------------------|-----------|--------------|
| Order No. | Intensity | Weight (Kg.) |
| 1-032-0010 | 75A, 100A | 1.54 |

Material : PVC., Steel, Copper

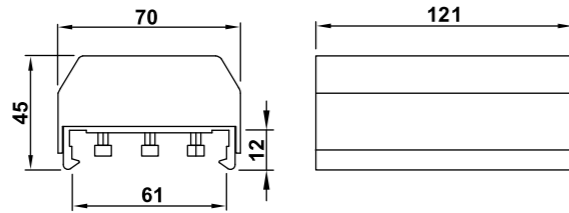

| 3P. Joint Middle Power Feed In | | |
|--------------------------------|------------|--------------|
| Order No. | References | Weight (Kg.) |
| 1-032-0005 | 100A | 0.23 |

Material : PVC., Steel, Copper

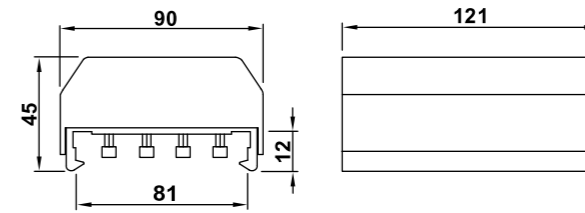

| 4P. Joint Middle Power Feed In | | |
|--------------------------------|-----------|--------------|
| Order No. | Intensity | Weight (Kg.) |
| 1-032-0011 | 75A, 100A | 0.35 |

Material : PVC., Steel, Copper

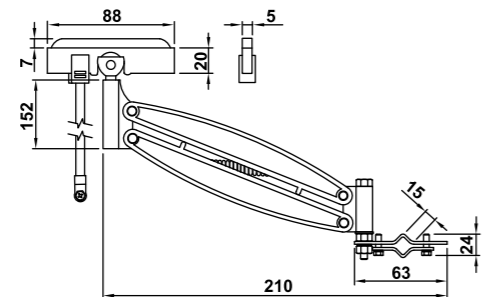

| 3P. Current Collector | | |
|-----------------------|-----------|--------------|
| Order No. | Intensity | Weight (Kg.) |
| 1-032-0006 | 60A | 0.20 |

Material : PVC., Steel, Copper

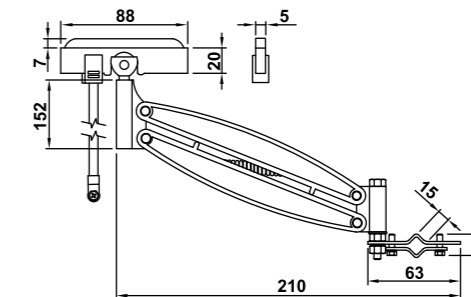

| 4P. Current Collector | | |
|-----------------------|-----------|--------------|
| Order No. | Intensity | Weight (Kg.) |
| 1-032-0012 | 75A, 100A | 1.05 |

Material : PVC., Steel, Copper

| Collector Shoe | | |
|----------------|-----------|--------------|
| Order No. | Intensity | Weight (Kg.) |
| 1-032-0013 | 60A | 0.10 |

Material : PVC., Copper

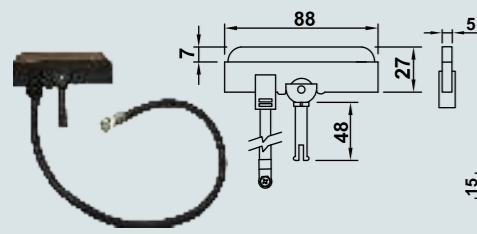

| Fix Square Bar | | |
|----------------|----------|--------------|
| Order No. | Max.Load | Weight (Kg.) |
| 1-032-0014 | 16 Kg. | 0.80 |

Material : Galvanized Steel

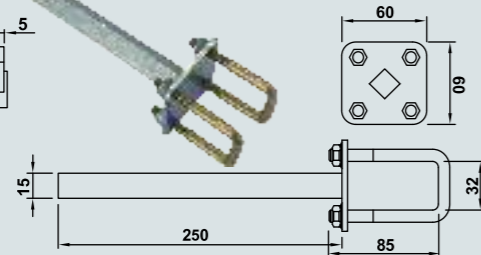

| Rectangular Pipe | | |
|------------------|----------|--------------|
| Order No. | Max.Load | Weight (Kg.) |
| 2-220-0013 | 750 | 1.2 |

Material : Galvanized Steel

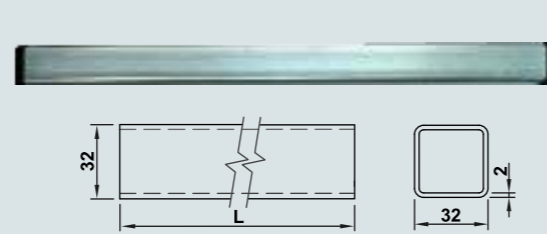

| Fix Square Bar | | |
|----------------|----------|--------------|
| Order No. | Max.Load | Weight (Kg.) |
| 2-220-0014 | 20 Kg. | 0.021 |

Material : Galvanized Steel

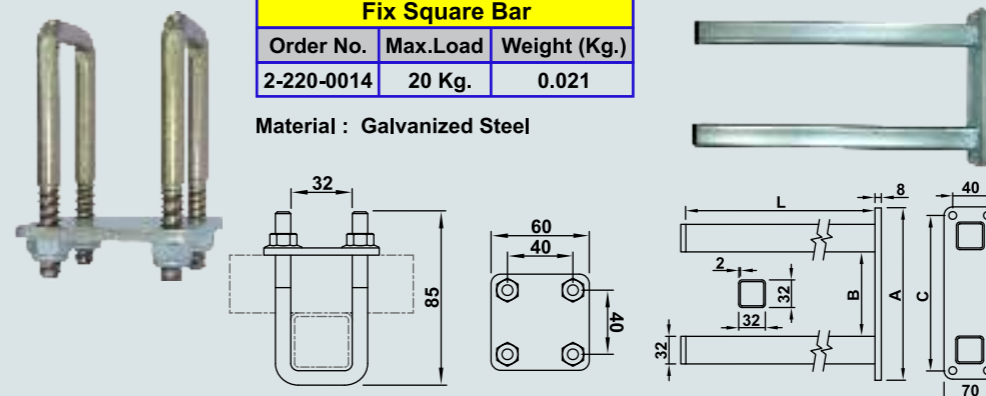

| Current Collector Towing Arm | | | | |
|------------------------------|--------------|-----------|---------|--------------|
| Order No. | End Carriage | Dimension | | Weight (Kg.) |
| | | (A) | (B) | |
| 3-230-0005 | 250 -500 | 270 mm. | 130 mm. | 2.5 |
| 3-230-0006 | 110 -200 | 270 mm. | 130 mm. | 2.1 |

Material : Galvanized Steel

End Carriage Type : 110 - 200 L = 400 mm.
 End Carriage Type : 250 - 500 L = 500 mm.
 Dimension Type : 110 - 200 C = 400 mm.
 Dimension Type : 250 - 500 L = 500 mm.

Assembly Instruction

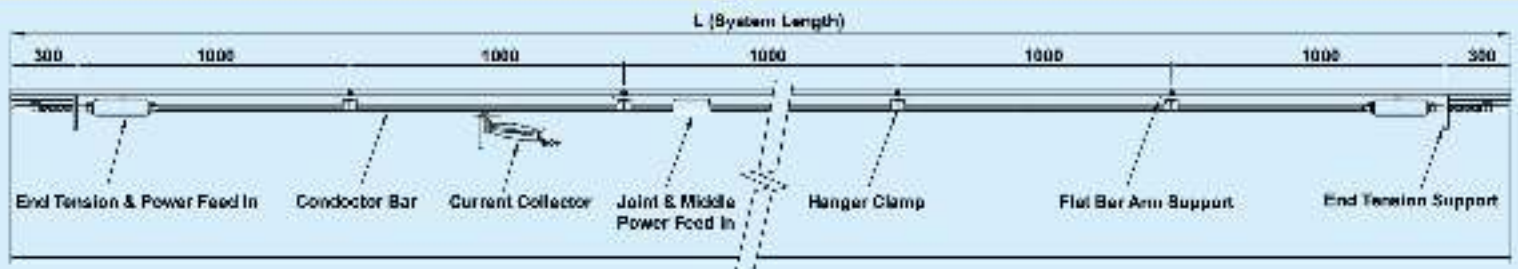

"Titan Conductor Bar Designed Accessories For Support

1. Current Collector Towing Arm
2. Rectangular Pipe
3. Rectangular Pipe Clamp
4. Fix Square Bar
5. Flat Bar Arm
6. Angle Support
7. C-track Arm
8. Welded Rail Support
9. Fastening Bracket
10. Hanger Clamp
11. Current Collector

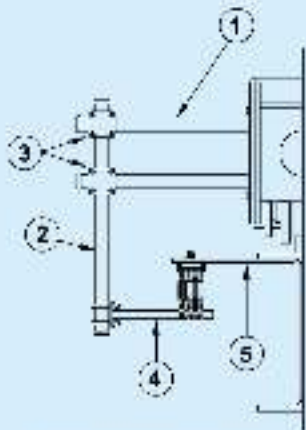

Fix Invert Line

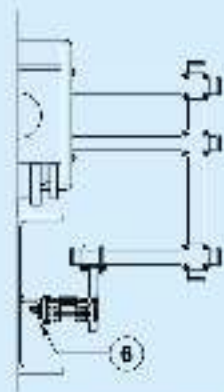

Fix Side Line

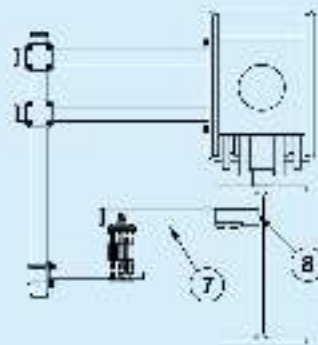

Adjustable Invert Line

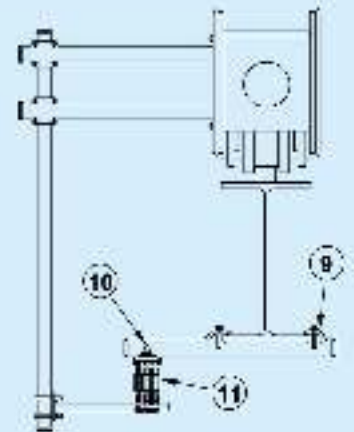

Slide Support Invert Line

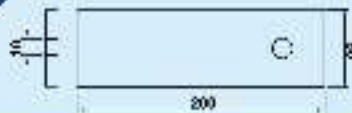
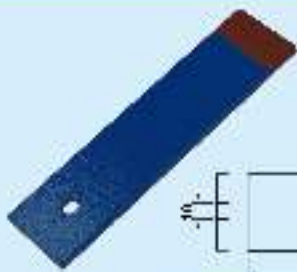

Flat Bar Arm Support

| Order No. | Length (L) | Weight (Kg.) |
|------------|------------|--------------|
| 3-230-0001 | 200 | 0.48 Kg. |

Material : Steel

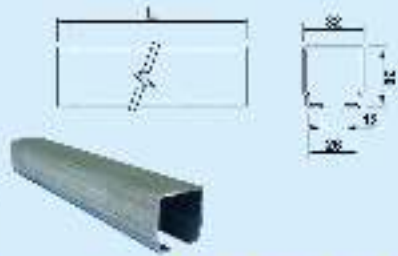

C-Track Arm Support

| Order No. | Max. Load |
|------------|-----------|
| 2-220-0020 | 16 Kg. |

Material : Galvanized Steel

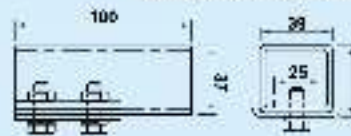
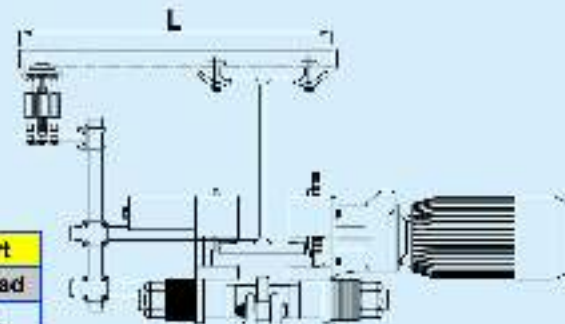

Welded Rail Support

| Order No. | Max. Load |
|------------|-----------|
| 2-220-0010 | 16 Kg. |

Material : Galvanized Steel



Angle Arm Support

| Order No. | Length (L) | Weight (Kg.) |
|------------|------------|--------------|
| 3-230-0015 | 100 | 0.99 Kg. |

Material : Steel



Fastening Bracket

| Order No. | Length (mm.) |
|------------|--------------|
| 1-030-0043 | 400 |
| 1-030-0044 | 500 |
| 1-030-0045 | 600 |

Material : Galvanized Steel

Titan Service Co., Ltd.

1/13 M.I. Pimpha, Bangkok,
Chachoengsao 24130, Thailand.

www.titanservice.co.th

info.titanservice@gmail.com

Sales Dep. Hotline : 08-1823-8281

Service Dep. Hotline : 06-3273-1222



www.titanservice.co.th



Titan Service App



LINE Titan service



Titan Service Channel



Titan Service Facebook