

Technology, Efficiency, Handiness
All There are possible at KUKDONG

KUKDONG



KOREA'S No.1 Hoists



www.thaicranekits.co.th



SPECIFICATIONS / MODEL CLASSIFICATION OF HOIST

Type & Model Selection

Explanation of KUKDONG Hoist

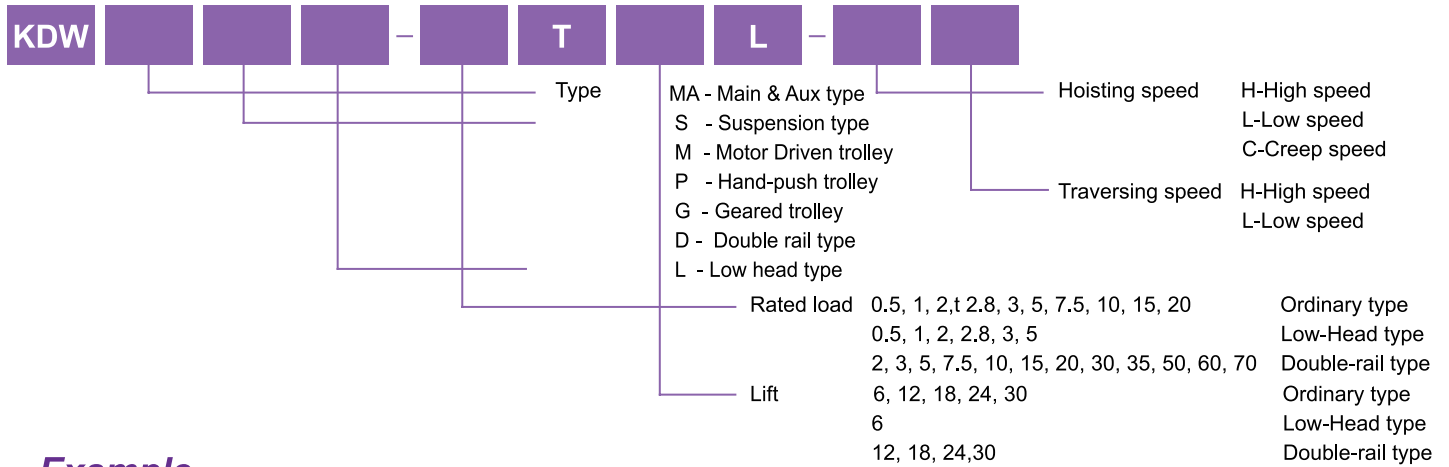

Example

KDWM-2T6L-HL : Ordinary type 2 ton, High speed 6m lift - motor trolley, low speed

KDWML-2T6L-HL : Low-head type 2 ton, High speed 6m lift - motor trolley, low speed

KDWD-2T5L-HL : Double-rail type 2 ton, High speed 6m lift - motor trolley, low speed

Optimum Model from Various Hoist type

TYPE	LIFT	0.5 ton	1 ton	2 ton	2.8 ton	3 ton	5 ton	7.5 ton	10 ton	15 ton	20 ton	30 ton
ORDINARY	6M	○	○	○	○	○	○					
	12M	○	○	○	○	○	○	○	○	○	○	○
	18M	○	○	○	○	○	○	○	○	○	○	○
	24M	○	○	○	○	○	○	○	○	○	○	○
	30M	○	○	○	○	○	○	○	○			
LOW HEAD	6M	○	○	○	○	○	○	○				
	9M	○	○	○	○	○	○	○				
DOUBLE	12M			○	○	○	○	○	○	○	○	○
	18M			○	○	○	○	○	○	○	○	○
	24M			○	○	○	○	○	○	○	○	○
	30M			○	○	○	○	○	○			
LOW DOUBLE	6M			○	○	○	○	○	○			

Cross-Section View

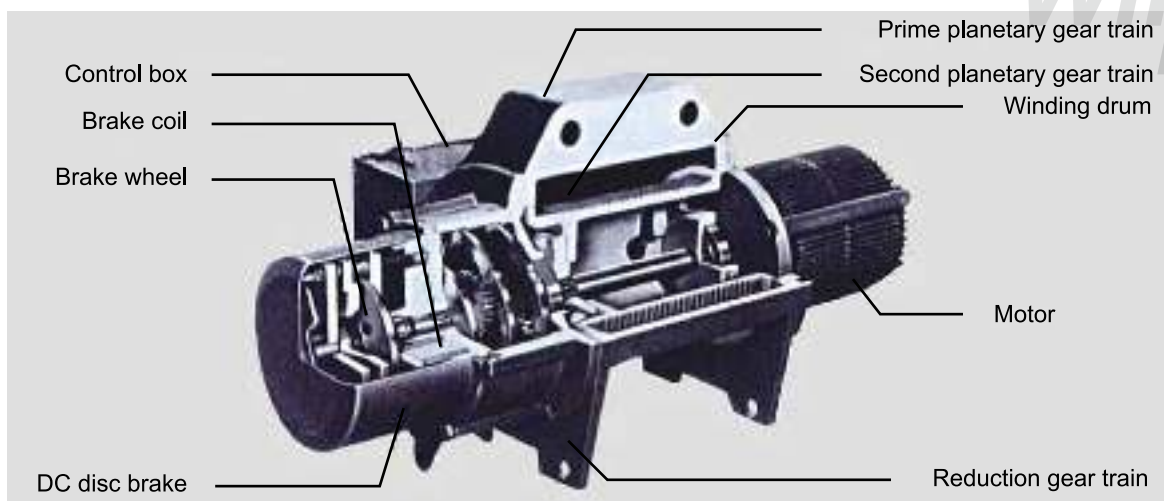

CLASSIFICATION OF MECHANISMS

FEM 9.511	1D _m	1C _m	1B _m	1A _m	2 _m	3 _m	4 _m	5 _m
BS 2573 P2	M1	M2	M3	M4	M5	M6	M7	M8
Hoist	Intermittent ratio (R1%)		25	30	40	50	60	>60
	No. of starts per hour (S/h)		150	180	240	300	360	>360
	No. of cycles per hours (C/h)		25	30	40	50	60	>60
Trolley	Intermittent ratio (R1%)		20	25	30	40	50	60
	No. of starts per hour (S/h)		120	150	180	240	300	360
	No. of starts per hour (S/h)		20	25	30	40	50	60
Two-Speed Double polarity motor								
No. of starts per hour (S/h)	Main speed	1/3 (33.3% of total starts per hour)						
	Slow speed	2/3 (66.7% of total starts per hour)						
Operating time per day	Main speed	2/3 (66.7% of average operating time per day)						
	Slow speed	1/3 (33.3% of average operating time per day)						
Used in temporary duty	Operating time at main speed (min.)	15	15	30	30	60	>60	
	Operating time at slow speed (min.)	2.5	15	3.5	4	5	6	
	Maximum number of starts per hour (s/h)	10	10	10	10	10	10	10

For applying to the hoist mechanisms are classified into the groups depending on operating conditions

The group into which a mechanism is classified is determined by the following factor:

- Class of operating time
- Load spectrum

Class of operating time

The class of operating time indicates the average period per day during which a mechanism is in operation (see table 1). A mechanism is considered to be in operation when it is in motion.

For mechanisms not regularly used during the year the average operating time per day is determined by the ratio of the annual operating time to 250 working days per year.

The higher classes of operating time apply only in such cases where a mechanism is operated during more than one shift per day.

Table 1

Average operating time per day (hours)

Operating time/day (h) = $\frac{2 \times \text{lifting height (m)} \times \text{number of cycles per hour} \times \text{working time/day (h)}}{60 \text{ (minutes per hour)} \times \text{lifting speed (m/min)}}$

Lifting height = The average hook travel under actual operating conditions (meter)

Cycles per hour = The average number of complete ascent/decant operations in an hour

Working time/day = The time during which the hoist is used on a working day (hour)

Lifting speed = The average lifting speed (normally the maximum lifting speed) at which the load cycles are performed. (Meter per minute)

Class of operating time		Average operating time per day (hours)	Calculated total operating time (hours)
EFM	BS		
V0.06	T0	≤ 0.12	200
V0.12	T1	≤ 0.25	400
V0.25	T2	≤ 0.5	800
V0.5	T3	≤ 1	1600
V1	T4	≤ 2	3200
V2	T5	≤ 4	6300
V3	T6	≤ 8	12500
V4	T7	≤ 16	25000
V5	T8	≤ 16	50000

Load spectrum

The load spectrum indicates to what extent a mechanism or part thereof is subject to maximum stress or whether it is subject to smaller load only.

Table 2

For an exact classification into groups the cubic mean value k referred to the safe working load is required. It is calculated by using the following formula :

$$k = \sqrt[3]{(\beta_1 + \gamma)^3 \cdot t_1 + (\beta_2 + \gamma)^3 \cdot t_2 + \dots + \gamma^3 \cdot t_\Delta}$$

Where : $\beta = \frac{\text{useful or partial load}}{\text{safe working load}}$

$\gamma = \frac{\text{dead load}}{\text{safe working load}}$

$t = \frac{\text{operating time under useful or partial load and dead load}}{\text{total operating time}}$

$t_\Delta = \frac{\text{operating time under dead load only}}{\text{total operating time}}$

Four load spectrum are distinguished which are determined by the definitions given and by the ranges covered by the cubic mean values k as listed in table 2

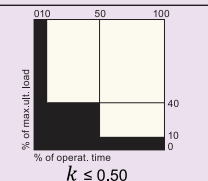
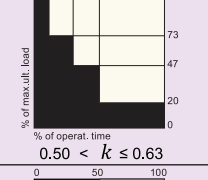
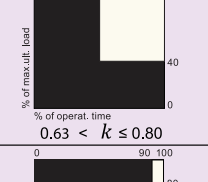
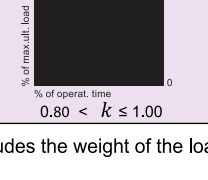
Load spectrum		Definitions	Cubic mean value
FEM	BS		
1 (light)	L1	Mechanisms or parts thereof, Usually subject to very small Loads and in exceptional cases Only to maximum loads	 $k \leq 0.50$
2 (medium)	L2	Mechanisms or parts thereof, Usually subject to small loads But rather often to maximum load	 $0.50 < k \leq 0.63$
3 (heavy)	L3	Mechanisms or parts thereof, Usually subject to medium Loads but frequently to Maximum loads	 $0.63 < k \leq 0.80$
4 (very heavy)	L4	Mechanisms or parts thereof, usually subject to maximum or almost maximum loads	 $0.80 < k \leq 1.00$

The formula given above for the cubic mean value k excludes the weight of the load carrying means.

This is acceptable if the ratio $\frac{\text{Weight of the load carrying means}}{\text{safe working load}} \leq 0.05$

By applying **The Classes of operating times** and **The Load Spectrum**,

The Mechanisms are classified into 8 groups :

Table 3

Classification of Mechanisms into 8 groups

Load spectrum		Class of operation time									
		V 0.06	V 0.12	V 0.25	V 0.5	V 1	V 2	V 3	V 4	V 5	
		T 0	T 1	T 2	T 3	T 4	T 5	T 6	T 7	T 8	
		Average operating time per day in hours									
FEM	BS	Cubic mean value	≤ 0.12	≤ 0.25	≤ 0.5	≤ 1	≤ 2	≤ 4	≤ 8	≤ 16	≤ 16
1 (light)	L1	$k \leq 0.50$			1 D _m	1 C _m	1 B _m	1 A _m	2 _m	3 _m	4 _m
					M1	M2	M3	M4	M5	M6	M7
2 (medium)	L2	$0.50 < k \leq 0.63$		1 D _m	1 C _m	1 B _m	1 A _m	2 _m	3 _m	4 _m	5 _m
				M1	M2	M3	M4	M5	M6	M7	M8
3 (heavy)	L3	$0.63 < k \leq 0.80$		1 D _m	1 C _m	1 B _m	1 A _m	2 _m	3 _m	4 _m	5 _m
				M1	M2	M3	M4	M5	M6	M7	M8
4 (very heavy)	L4	$0.80 < k \leq 1.00$		1 C _m	1 B _m	1 A _m	2 _m	3 _m	4 _m	5 _m	
				M2	M3	M4	M5	M6	M7	M8	

The result of the classification of mechanism into groups according to table 3 is that the same life, expressed in years, may be expected for these machines under all load spectrum and average operating times per day. This applies on condition that the life of the individual component depends on the third power of the load.

The average daily operating time with in the classes of operating times are doubled as follows:

1. Within a group by passing into a lower load spectrum (progression 1.25), because $1.25^3 = 2$.
2. Within a load spectrum by passing into a higher group and derating the SWL by the factor of 1.25, because $1.25^3 = 2$.

DOUBLE GIRDER Electric Wire Rope Hoists

KDWD Model

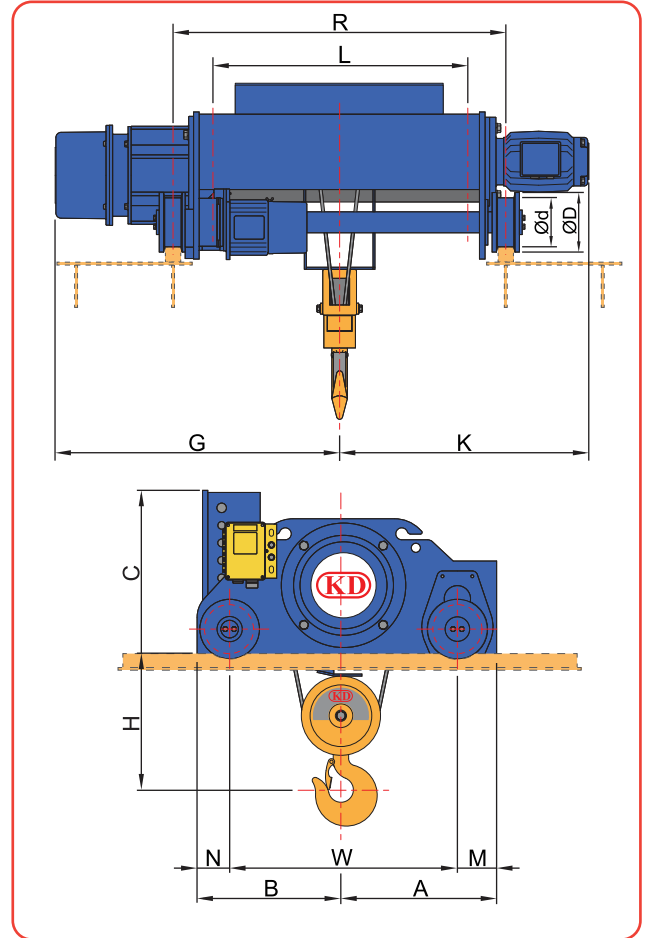

Standard Specification

Model Hoist	Capacity (Ton)	Lift Height (m)	Duty Rating %ED	Hoist Class (FEM)	Hoist			Trolley *			Wire Rope		Approx Weight (kg.)
					Lifting Speed (m./min.)	Motor kw./Pole	Brake	Traversing (m./min.)	Motor kw./Pole	Brake	Diameter (mm.)	Number of Falls	
KDWD	3	12	40	2M	7.5	5.5 / 4	D.C. Magnetic Disc Brake	13	0.5 / 6	D.C. Magnetic Disc Brake	Ø9	4	550
	5	12	40	2M	4.7	5.5 / 6		13	0.5 / 6		Ø12.5	4	850
	7.5	12	40	2M	3.1	5.5 / 6		12.5	0.75 / 4		Ø14	4	900
	10	12	40	2M	3.7	9 / 8		12.5	0.75 / 4		Ø16	4	1200
	15	12	40	2M	3.7	13 / 8		12.5	1.5 / 4		Ø20	4	1850
	20	12	40	2M	3.5	17 / 8		12.5	1.5 / 4		Ø22.4	4	2300
	30	12	40	2M	2.3	17 / 8		12.5	1.5 / 4**		Ø22.4	6	3450

* Optional Inverter Trolley, Galvanized Steel, Upper and Lower Adjustable Limit Switches, Limit Cut-off, Overheating Protection, Please contact distributor.

** Motor 2 units

*** Hoist Power Supply : AC 3Ph. 380V. 50Hz.

Dimension

Model Hoist	Capacity (Ton)	Approx. Dimension (mm.)													
		A	B	C	ØD	Ød	G	H	K	L	M	N	R	W	
KDWD	3	465	390	550	170	140	785	420	705	690	120	95	950	650	
	5	510	470	590	195	165	945	510	845	890	120	105	1150	760	
	7.5	525	480	550	195	165	935	730	835	850	110	95	1150	800	
	10	565	510	670	195	165	975	775	955	850	110	100	1150	865	
	15	625	555	850	210	180	1075	995	1005	870	130	130	1200	920	
	20	670	615	870	250	220	1165	1175	1195	935	140	140	1300	1000	
	30	940	940	935	280	250	1425	1790	1455	1420	180	160	1800	1540	

• The design, material and specification are subject to change for improvement without notice.

• A special specification is available upon request.

DOUBLE GIRDER Electric Wire Rope Hoists

KDWDC Model

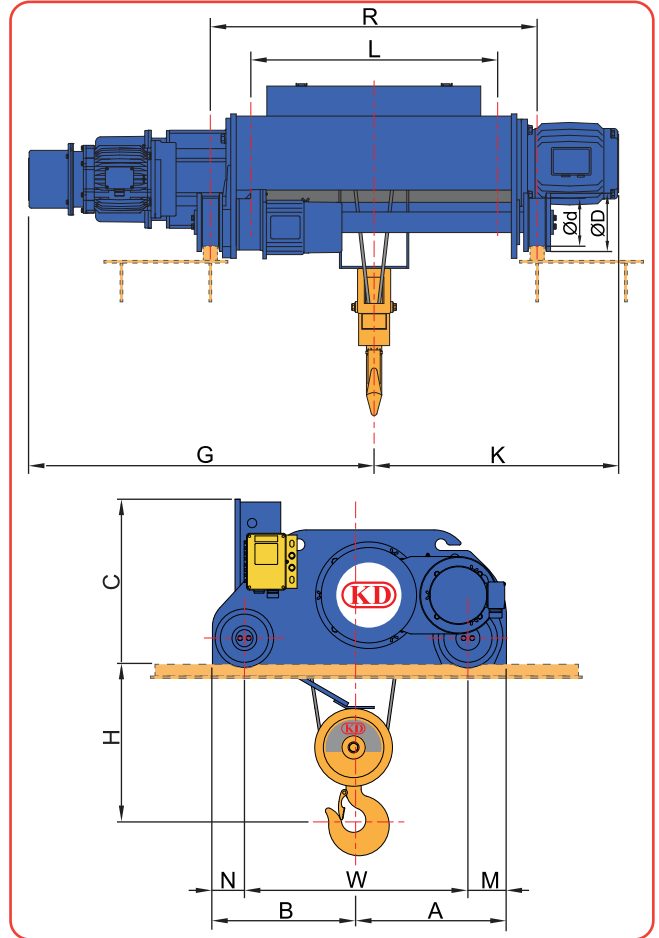

Standard Specification

Model Hoist	Capacity (Ton)	Lift Height (m)	Duty Rating %ED	Hoist Class (fem)	Hoist			Trolley *			Wire Rope		Approx Weight (kg.)
					Lifting Speed (m./min.)	Motor kw./Pole	Brake	Traversing (m./min.)	Motor kw./Pole	Brake	Diameter (mm.)	Number of Falls	
KDWDC	3	12	40	2M	7.5/0.75	5.5/4	D.C. Magnetic Disc Brake	20	0.75/4	D.C. Magnetic Disc Brake	Ø9	4	590
	5	12	40	2M	4.7/0.47	5.5/6		20	0.75/4		Ø12.5	4	900
	7.5	12	40	2M	3.1/0.41	5.5/6		12.5	0.75/4		Ø14	4	955
	10	12	40	2M	3.7/0.37	9/8		12.5	0.75/4		Ø16	4	1265
	15	12	40	2M	3.7/0.37	13/8		12.5	1.5/4		Ø20	4	1920
	20	12	40	2M	3.5/0.35	17/8		12.5	1.5/4		Ø22.4	4	2385
	30	12	40	2M	2.3/0.23	17/8		12.5	1.5/2**		Ø22.4	6	3536

* Optional Inverter Trolley, Galvanized Steel, Upper and Lower Adjustable Limit Switches, Limit Cut-off, Overheating Protection, Please contact distributor.

** Motor 2 units

*** Hoist Power Supply : AC 3Ph. 380V. 50Hz.

Dimension

Model Hoist	Capacity (Ton)	Approx. Dimension (mm.)													
		A	B	C	ØD	Ød	G	H	K	L	M	N	R	W	
KDWDC	3	465	390	380	170	140	1025	420	705	690	120	95	950	650	
	5	510	470	620	195	165	1170	510	705	890	120	105	1150	760	
	7.5	525	480	580	195	165	1170	730	835	850	110	95	1150	800	
	10	565	510	700	195	165	1225	775	955	850	110	100	1150	865	
	15	625	555	850	210	180	1365	955	1005	870	130	130	1200	920	
	20	670	615	900	250	220	1460	1175	1195	935	140	140	1300	1000	
	30	940	940	935	280	250	1720	1480	1455	1420	180	180	1800	1540	

- The design, material and specification are subject to change for improvement without notice.
- A special specification is available upon request.

SINGLE GIRDER Electric Wire Rope Hoists

KDWM Model

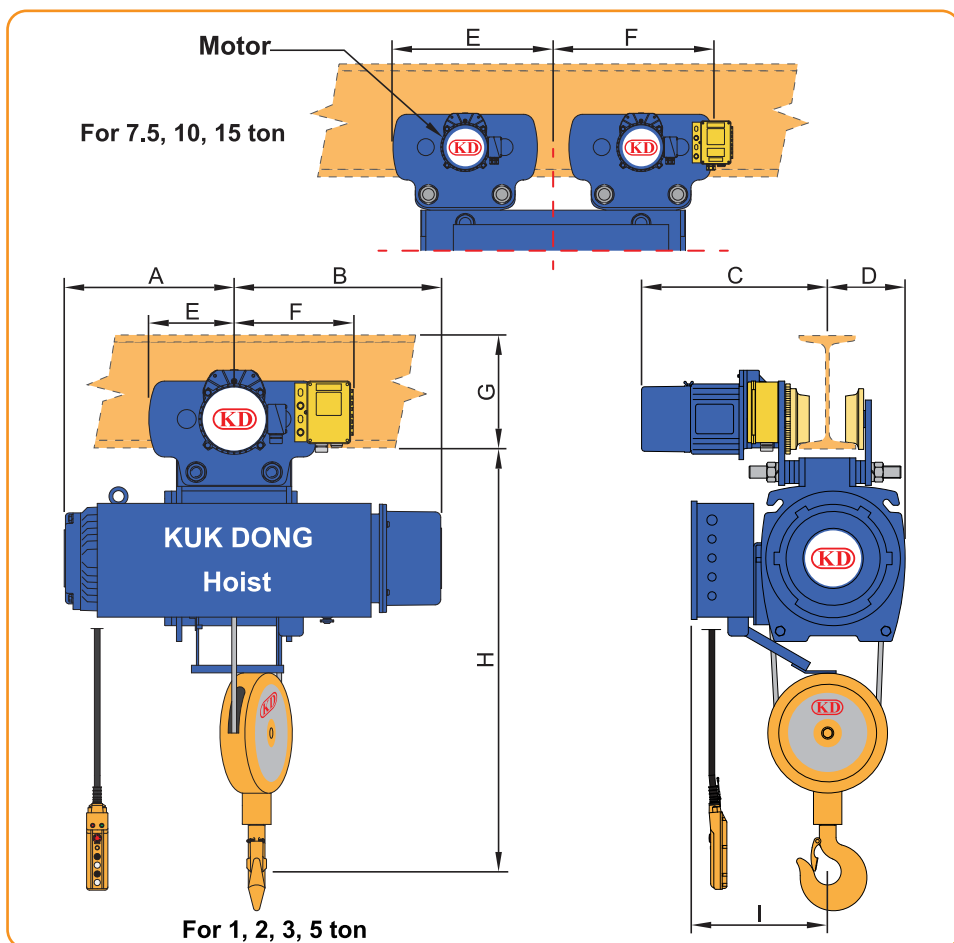

Standard Specification

Model Hoist	Capacity (Ton)	Lift Height (m)	Duty Rating %ED	Hoist Class (FEM)	Hoist			Trolley *			Wire Rope		Approx Weight (kg.)
					Lifting Speed (m./min.)	Motor kw./Pole	Brake	Traversing (m./min.)	Motor kw./Pole	Brake	Diameter (mm.)	Number of Falls	
KDWM	1	6, 12	40	2M	10	2.4 / 4	D.C. Magnetic Disc Brake	13	0.2 / 6	D.C. Magnetic Disc Brake	Ø8	2	190, 218
	2	6, 12	40	2M	8.4	3.7 / 4		13	0.5 / 6		Ø10	2	278, 314
	3	6, 12	40	2M	7.5	5.5 / 4		13	0.5 / 6		Ø12.5	2	374, 418
	5	6, 12	40	2M	4.7	5.5 / 6		13	0.5 / 6		Ø16	2	577, 642
	7.5	12	40	2M	3.1	5.5 / 6		12.5	0.75 / 4 **		Ø14	4	910
	10	12	40	2M	3.7	9 / 8		12.5	0.75 / 4 **		Ø16	4	1210
	15	12	40	2M	3.7	13 / 8	12.5	1.5 / 4 **	Ø20	4	2030		

* Optional Inverter Trolley, Galvanized Steel, Upper and Lower Adjustable Limit Switches, Limit Cut-off, Overheating Protection, Please contact distributor.

** Motor 2 Units

*** Hoist Power Supply : AC 3Ph. 380V. 50Hz.

Dimension

Model Hoist	Capacity (Ton)	Approx. Dimension (mm.)									Adj. Fix I-Beam (mm.)	Trolley Min. Radius curve (mm.)
		A	B	C	D	E	F	G	H	I		
KDWM	1	380 (560)	400 (425)	400	165	255	200	155	815	275	75 - 125	1500
	2	380 (425)	400 (425)	467	195	260	225	182	980	310	75 - 125	1800
	3	430 (590)	465 (485)	467	200	260	225	182	1115	365	100 - 125	1800
	5	515 (705)	615 (625)	490	240	275	275	224	1325	405	100 - 125	2300
	7.5	835	935	495	295	650	675	800	1460	460	145 - 495	for straight rail only
	10	955	975	495	320	650	675	800	1520	510	145 - 495	
15	1005	1075	590	365	670	700	800	1875	640	145 - 495		

- The design, material and specification are subject to change for improvement without notice.
- A special specification is available upon request.

SINGLE GIRDER Electric Wire Rope Hoists

KDWMC Model

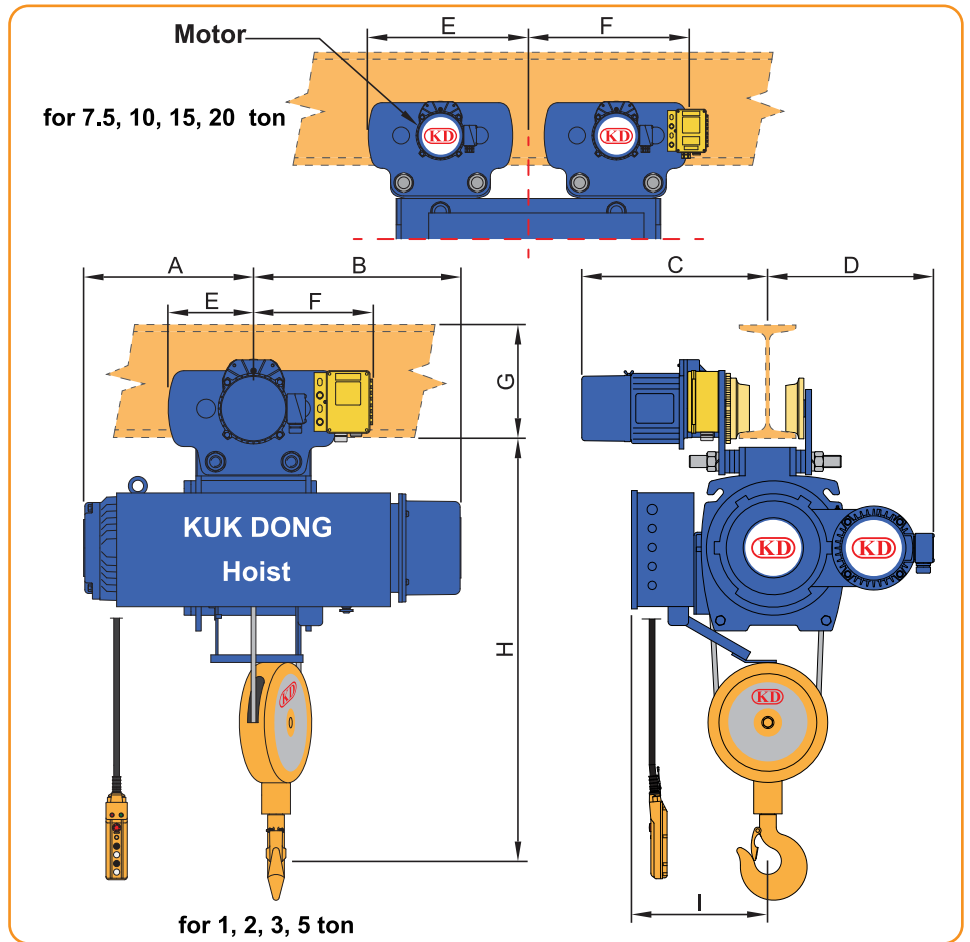

Standard Specification

Model Hoist	Capacity (Ton)	Lift Height (m)	Duty Rating %ED	Hoist Class (FEM)	Hoist			Trolley *			Wire Rope		Approx Weight (kg.)
					Lifting Speed (m./min.)	Motor kw./Pole	Brake	Traversing (m./min.)	Motor kw./Pole	Brake	Diameter (mm.)	Number of Falls	
KDWMC	1	6, 12	40	2M	10 / 1.0	2.4 / 4	D.C. Magnetic Disc Brake	20	0.4 / 4	D.C. Magnetic Disc Brake	Ø8	2	225, 245
	2	6, 12	40	2M	8.4 / 0.84	3.7 / 4		20	0.75 / 4		Ø10	2	415, 460
	3	6, 12	40	2M	7.5 / 0.75	5.5 / 4		20	0.75 / 4		Ø12.5	2	415, 460
	5	6, 12	40	2M	4.7 / 0.47	5.5 / 6		20	0.75 / 4		Ø16	2	635, 700
	7.5	12	40	2M	3.1 / 0.41	5.5 / 6		12.5	0.75 / 4**		Ø14	4	970
	10	12	40	2M	3.7 / 0.37	9 / 8		12.5	0.75 / 4**		Ø16	4	1280
	15	12	40	2M	3.7 / 0.37	13 / 8		12.5	1.5 / 4**		Ø20	4	2180
	20	12	40	2M	3.5 / 0.37	17 / 8		12.5	1.5 / 4**		Ø22	4	2520

* Optional Inverter Trolley, Galvanized Steel, Upper and Lower Adjustable Limit Switches, Limit Cut-off, Overheating Protection, Please contact distributor.

** Motor 2 Units

*** Hoist Power Supply : AC 3Ph. 380V. 50Hz.

Dimension

Model Hoist	Capacity (Ton)	Approx. Dimension (mm.)									Adj. Fix I-Beam (mm.)	Trolley Min. Radius curve (mm.)
		A	B	C	D	E	F	G	H	I		
KDWMC	1	380 (560)	595 (615)	415	375	255	200	155	815	-	75 - 125	*1500
	2	430 (590)	635 (675)	465	380	260	225	182	980	-	75 - 125	*1800
	3	445 (635)	760 (770)	465	445	260	225	182	1115	-	100 - 125	*1800
	5	515 (705)	840 (850)	480	470	275	275	224	1325	-	100 - 125	*2300
	7.5	835	1170	495	505	662.5	662.5	800	1460	465	145 - 495	*for straight rail only
	10	955	1225	495	570	662.5	662.5	800	1520	530	145 - 495	
	15	1005	1365	590	620	685	685	800	1875	615	145 - 495	
20	1195	1460	590	660	710	710	800	2115	640	145 - 600		

- The design, material and specification are subject to change for improvement without notice.
- A special specification is available upon request.

KD-1 & KD-2 Type Electric Chain Hoists

KD-1 Model

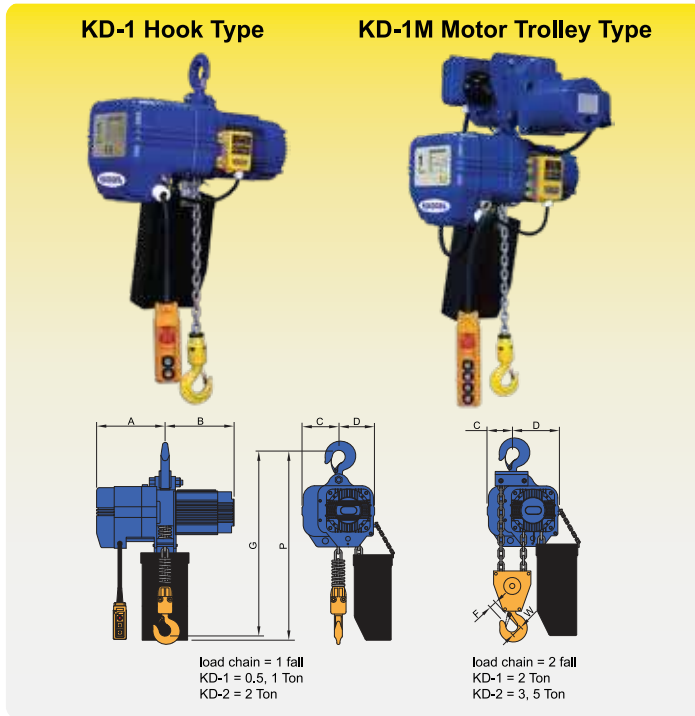

KD-2 Model

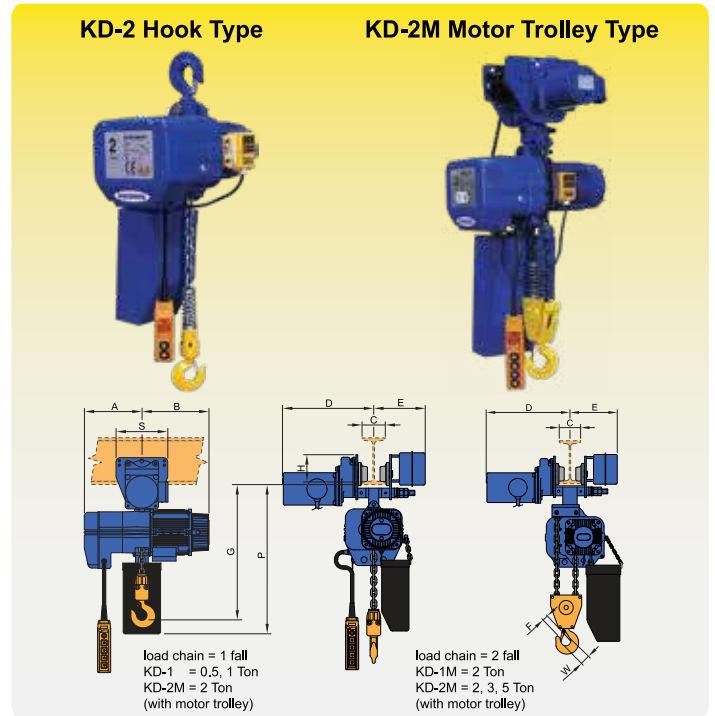

● KD-1 Standard Specification

Model Hoist	Capacity (Ton)	Lift Height (m.)	Duty Rating (%ED)	Hoist Class (FEM)	Hoist				Brake	Trolley			Load Chain		Net Weight (Kg.)
					Lifting Speed (m/min.)		Motor (kw.)			Traversing Speed (m/min.)	Motor (kw.)	Brake	Diameter (mm.)	Number of Falls	
					Single	Double	Single	Double							
KD-1	0.5	4	25	1Bm	6.7	6.7 / 1.7	0.8	0.8 / 0.2	D.C. Magnetic Disc Brake	-	-	D.C. Magnetic Disc Brake	Ø7.1	1	55 (57)
	1	4	25	1Bm	6.7	6.7 / 1.7	1.5	1.5 / 0.38		-	-		Ø7.1	1	59 (61)
	2	4	25	1Bm	3.4	3.4 / 0.9	1.5	1.5 / 0.38		-	-		Ø7.1	2	75 (77)
KD-1M	0.5	4	25	1Bm	6.7	6.7 / 1.7	0.8	0.8 / 0.2	D.C. Magnetic Disc Brake	10	0.4	D.C. Magnetic Disc Brake	Ø7.1	1	95 (97)
	1	4	25	1Bm	6.7	6.7 / 1.7	1.5	1.5 / 0.38		10	0.4		Ø7.1	1	100 (102)
	2	4	25	1Bm	3.4	3.4 / 0.9	1.5	1.5 / 0.38		10	0.4		Ø7.1	2	115 (117)

● Dimension

Model Hoist	Capacity (Ton)	Approx. Dimension (mm.)											Adj. Fix I-Beam (mm.)	Trolley Min. Radius Curve (mm.)
		A	B	C	D	E	F	H	S	W	P	G		
KD-1	0.5	258	265	132	132	-	29	-	-	40	663	450	-	-
	1	258	308	132	132	-	29	-	-	40	663	450	-	-
	2	258	308	132	167	-	34	-	-	50	683	640	-	-
KD-1M	0.5	258	265	75, 100, 125	338	218	29	121	230	40	663	435	75, 100, 125	1000
	1	258	308	75, 100, 125	350	230	29	121	230	40	663	435	75, 100, 125	1000
	2	258	308	75, 100, 125	365	243	34	123	296	50	667	670	100, 125, 150	1500

● KD-2 Standard Specification

Model Hoist	Capacity (Ton)	Lift Height (m.)	Duty Rating (%ED)	Hoist Class (FEM)	Hoist				Brake	Trolley			Load Chain		Net Weight (Kg.)
					Lifting Speed (m/min.)		Motor (kw.)			Traversing Speed (m/min.)	Motor (kw.)	Brake	Diameter (mm.)	Number of Falls	
					Single	Double	Single	Double							
KD-2	2	4	25	1Bm	6.8	6.8 / 1.7	3.3	3.3 / 0.825	D.C. Magnetic Disc Brake	-	-	D.C. Magnetic Disc Brake	Ø11.2	1	137 (147)
	3	4	25	1Bm	4.3	4.3 / 1.1	3.3	3.3 / 0.825		-	-		Ø9.5	2	151 (161)
	5	4	25	1Bm	3.0	3.0 / 0.8	3.3	3.3 / 0.825		-	-		Ø11.2	2	160 (170)
KD-2M	2	4	25	1Bm	6.8	6.8 / 1.7	3.3	3.3 / 0.825	D.C. Magnetic Disc Brake	10	0.4	D.C. Magnetic Disc Brake	Ø11.2	1	177 (187)
	3	4	25	1Bm	4.3	4.3 / 1.1	3.3	3.3 / 0.325		10	0.4		Ø9.5	2	208 (218)
	5	4	25	1Bm	3.0	3.0 / 0.8	3.3	3.3 / 0.825		10	0.4		Ø11.2	2	243 (253)

● Dimension

Model Hoist	Capacity (Ton)	Approx. Dimension (mm.)											Adj. Fix I-Beam (mm.)	Trolley Min. Radius Curve (mm.)
		A	B	C	D	E	F	H	S	W	P	G		
KD-2	2	307	355 (392)	168	168	-	34	-	-	50	805	790	-	-
	3	307	355 (392)	113	223	-	41	-	-	60	895	970	-	-
	5	307	355 (392)	113	223	-	48	-	-	67	970	1095	-	-
KD-2M	2	307	355 (392)	125	254	418	34	123	296	60	770	755	100, 125, 150	1500
	3	307	355 (392)	125	254	357	41	136	337	60	900	925	100, 125, 150	1500
	5	307	355 (392)	150	270	443	48	158	384	67	950	1054	125, 150, 175	2000

*** Hoist Power Supply : AC 3Ph. 380V. 50Hz.

MN & MNP Type MINI Electric Chain Hoists

MN & MNP Model

MN Hook Type

MNP Plain Trolley Type



Push Button

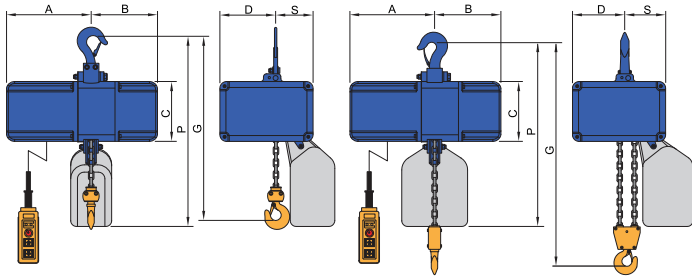

load chain = 1 fall
MN125 = 125 kg.
MN250 = 250 kg.

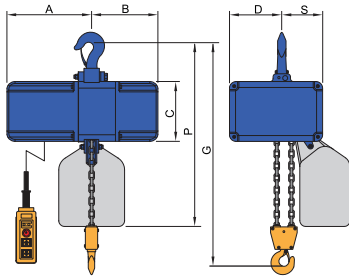

load chain = 2 fall
MN500 = 500 kg.

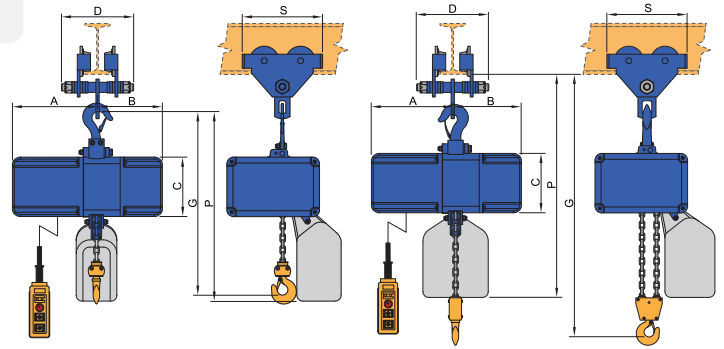

load chain = 1 fall
MNP125 = 125 kg.
MNP250 = 250 kg.

load chain = 2 fall
MNP500 = 500 kg.

Standard Specification

Model Hoist	Capacity (kg)	Lift Height (m.)	Duty Rating (%ED)	Hoist Class (EFM)	Hoist				Trolley		Load Chain		Net Weight (kg.)
					Lifting Speed (m/min.)		DC. Motor (Watt)	Brake	Traversing Speed (m/min.)	Motor (kw)	Diameter (mm.)	Number of Falls	
					Speed	Variable							
MN	125	4	30	1Bm	10	0 - 15	750	Mechanical with slip clutch	-	-	Ø4	1	18
	250	4	30	1Bm	10	0 - 15	750		-	-	Ø4	1	18
	500	4	30	1Bm	5	0 - 7	750		-	-	Ø4	2	25
MNP	125	4	30	1Bm	10	0 - 15	750		-	-	Ø4	1	26
	250	4	30	1Bm	10	0 - 15	750		-	-	Ø4	1	26
	500	4	30	1Bm	5	0 - 7	750		-	-	Ø4	2	32

Dimension

Model Hoist	Capacity (kg)	Approx Dimension (mm.)								Adj. Fix I-Beam (mm.)	Trolley Min. Radius Curve (mm.)
		A	B	C	D	G	P	S			
MN	125	166	143	130	126	340	340	79	-	-	
	250	166	143	130	126	340	340	79	-	-	
	500	166	143	130	126	400	400	79	-	-	
MNP	125	166	143	130	309	450	550	212	64~140	900	
	250	166	143	130	309	450	550	212	64~140	900	
	500	166	143	130	309	525	435	212	64~140	900	

*** Hoist Power Supply : AC 3Ph. 380V. 50Hz.

KM, KG & KP Type Hoist Trolleys

KM Model

Motor Gear Trolley Type Available from : 0.5 to 5 Ton Capacity

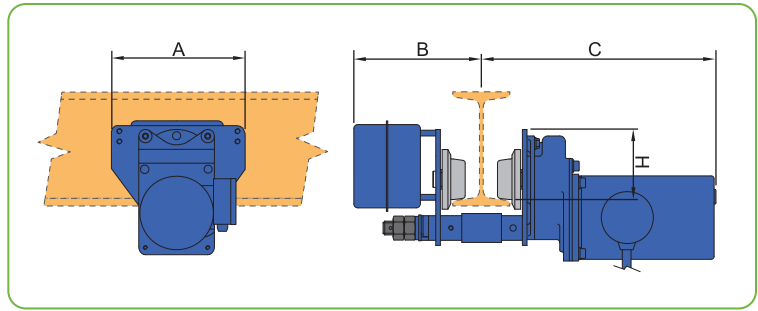

© Dimension

Model	Capacity (Ton)	Trolley Min. Radius Curve (mm.)	Test Load (kg.)	Net Weight (kg.)	Adj. Fix I-Beam (mm.)	Approx. Dimension (mm.)			
						A	B	C	H
KM-0.5	0.5	1000	0.62	40	75, 100, 125	230	218	338	121
KM-1	1	1000	1.25	40	75, 100, 125	230	230	350	121
KM-2	2	1500	2.5	40	100, 125, 150	296	245	418	123
KM-3	3	1500	3.7	57	100, 125, 150	373	254	357	136
KM-5	5	2000	6.2	83	125, 150, 175	384	270	443	158

KG Model

Gear Trolley Type Available from : 0.5 to 5 Ton Capacity

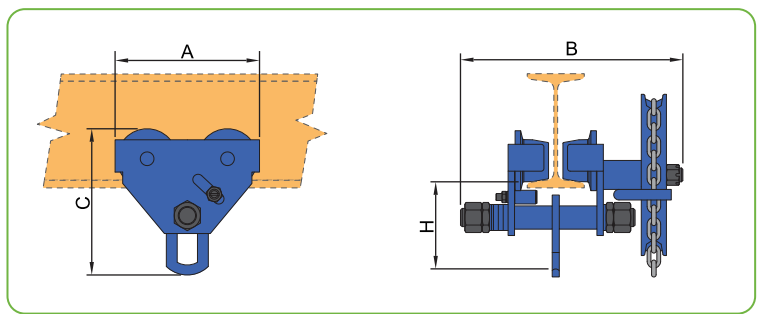

© Dimension

Model	Capacity (Ton)	Trolley Min. Radius Curve (mm.)	Test Load (kg.)	Net Weight (kg.)	Adj. Fix I-Beam (mm.)	Approx. Dimension (mm.)			
						A	B	C	H
KG-0.5	0.5	900	0.75	14	64 ~ 140	212	308.5	198.5	113
KG-1	1	1000	1.5	19	64 ~ 140	255	328.5	231.5	128
KG-2	2	1100	3	29	64 ~ 140	302	361.5	278	152
KG-3	3	1300	4.5	40	76 ~ 203	344	428.5	338	186
KG-5	5	1400	7.5	65	88 ~ 203	378	434	393	219

KP Model

Plain Trolley type Available from : 0.5 to 5 Ton Capacity

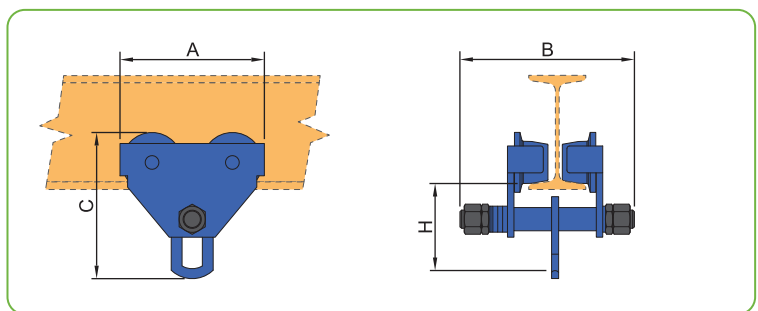

© Dimension

Model	Capacity (Ton)	Trolley Min. Radius Curve (mm.)	Test Load (kg.)	Net Weight (kg.)	Adj. Fix I-Beam (mm.)	Approx. Dimension (mm.)			
						A	B	C	H
KP-0.5	0.5	900	0.75	7	64 ~ 140	212	230	198.5	113
KP-1	1	1000	1.5	12	64 ~ 140	255	254	231.5	128
KP-2	2	1100	3	22	76 ~ 165	302	294	278	152
KP-3	3	1300	4.5	40	76 ~ 203	344	344	338	186
KP-5	5	1400	7.5	55	88 ~ 203	378	360	393	219

CHAIN BLOCK (KC-70A) Type Chain Block

KC-70A Model

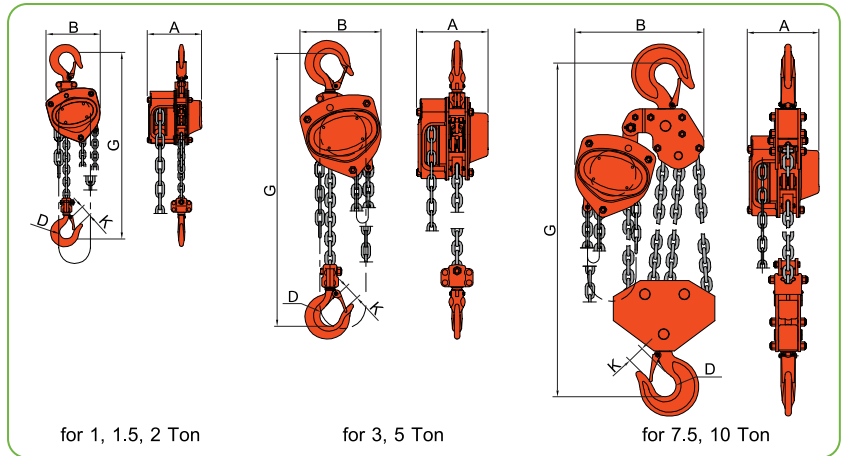

Dimension

Model	Capacity (Ton)	Lift (m)	Test Load (Ton)	Pulling Effort (kg)	Load chain (Ø x mm)	Hand chain (Ø x mm)	Dimension (mm)					Net Weight (kg)	Extra Weight 1M Lift (kg)
							A	B	G	D	K		
KC-70A-0.5T	0.5	2.5	0.75	24	6 x 1	5.0 x 25	131	127	270	35	30	10	0.8
KC-70A-1T	1	2.5	1.5	32	6 x 1	5.0 x 25	140	158	317	40	28	12	0.8
KC-70A-1.5T	1.5	2.5	2.3	33	8 x 1	5.0 x 25	161	174	399	45	36	19	1.4
KC-70A-2T	2	3	3	37	8 x 1	5.0 x 25	161	187	414	50	33.5	20	1.4
KC-70A-3T	3	3	4.5	35	8 x 2	5.0 x 25	161	199	465	58	40	27	2.8
KC-70A-5T	5	3	7.5	42	10 x 2	5.0 x 25	186	253	636	64	50	45.5	4.4
KC-70A-7.5T	7.5	3	9.4	35	10 x 4	5.0 x 25	207	398	778	85	64	66	6.6
KC-70A-10T	10	3	12.5	42	10 x 4	5.0 x 25	207	398	798	85	64	83	8.8

LIVER BLOCK (LB-90A) Type Liver Block

LB-90A Model

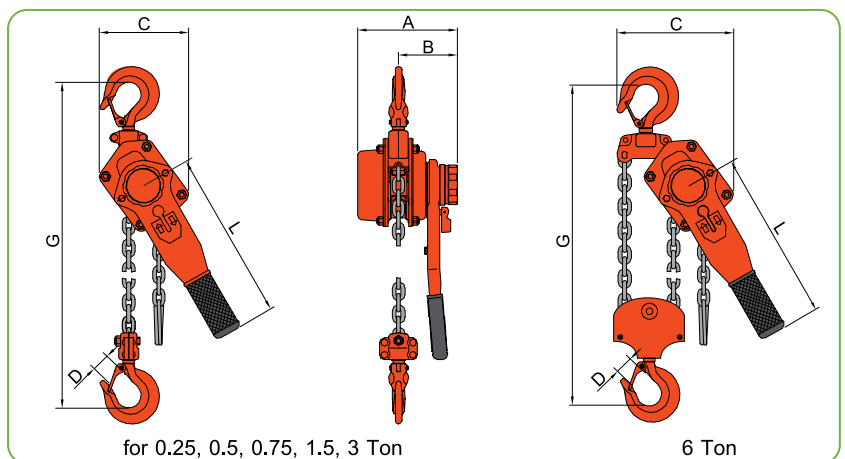

Dimension

Model	Capacity (Ton)	Lift (m)	Test Load (ton)	Pulling Effort (kg)	Load chain (Ø x falls)	Dimension (mm)						Net Weight (kg)	Extra Weight 1M Lift (kg)
						A	B	C	D	G	L		
LB-90A	0.25	1	0.38	25	4 x 1	92	72	85	25	230	160	1.8	0.4
	0.5	1.5	0.75	34	5 x 1	105	78	80	30	260	300	4.0	0.5
	0.75	1.5	1.13	14	6 x 1	145	86	122	37	325	280	7.5	0.8
	1.5	1.5	2.25	22	8 x 1	175	100	130	45	380	410	11.5	1.4
	3	1.5	4.5	32	10 x 1	203	118	150	50	480	410	21	2.2
	6	1.5	7.5	34	10 x 2	203	118	205	64	620	410	31.5	4.4

Hoist Specifications

Electric Wire Rope Hoist



- Hoist Classification : FEM 2M / ISO M5
- Test Load : Static Test Load 125% Dynamic Test Load 110% of Safe Working Load
- Ambient temperature : -20°C - +40°C
- Intermittent Rating (%ED) : 40% ED
- International Protection : IP55
- Hoist & Trolley Motor System : Squirrel Cage & Cylindrical Rotor
- Motor & Brake Wire Insulation : "F" Class
- Hoist Gear System : Direct Drive Planetary Gear Permanently Immersed in Oil
- Trolley Gear System : Rim Spur Gear
- Hoist Brake System : DC Magnetic Disc Brake
- Wire Rope Construction : 6x37 IWRC
- Hoist Lifting Speed : Single & Double Speed for Standard
- Electric Power Supply : AC 3Ph. 380V. 50Hz.
- Electric Control : 48V.
- Operation Method : Via Control Cable with Push Button Switch and Emergency Stop
- Upper Lifting Protection : 2 step Hinge Upper Limit Switch (1st Step Upper Control Cut Off. 2nd Electric Power Cut Off)
- Current Protection : Over Current Protection

Electric Chain Hoist



- Hoist Classification : FEM 1Bm / ISO M3
- Test Load : Static Test Load 125% Dynamic Test Load 110% of Safe Working Load
- Ambient temperature : -20°C - +40°C
- Intermittent Rating (%ED) : 25% ED
- International Protection : IP55
- Hoist Motor System : Squirrel Cage & Cylindrical Rotor with Aluminum Case
- Trolley Motor System : Squirrel Car & Cylindrical Sliding Rotor
- Motor & Brake Wire Insulation : "F" Class
- Hoist Gear System : Rim Spur Gear with Overload Slipping Clutch Immersed in Oil
- Trolley Gear System : Rim Spur Gear
- Hoist Brake System : DC Magnetic Disc Brake
- Trolley Brake System : Sliding Drum Brake
- Load Chain Construction : Alloy Steel Grade-80 Hardness HV600, Elongation 6%, Galvanize Coating.
- Hoist Lifting Speed : Single & Double Speed for Standard
- Electric Power Supply : AC 3Ph. 380V. 50Hz.
- Electric Control : 48V.
- Operation Method : Via Control Cable with Push Button Switch and Emergency Stop
- Upper & Lower Protection : Safety Slipping Clutch
- Chain Bucket : Plastic Box

"MINI" Electric Chain Hoist



- Hoist Classification : FEM 1Bm / ISO M3
- Test Load : Static Test Load 125% Dynamic Test Load 110% of Safe Working Load
- Ambient temperature : -20°C - +40°C
- Intermittent Rating (%ED) : 30% ED
- International Protection : IP55
- Hoist Motor System : Brushless DC Motor 750w
- Motor & Brake Wire Insulation : "B" Class
- Hoist Gear System : Rim Spur Gear with Overload Slipping Clutch Immersed in Oil
- Hoist Brake System : Mechanical brake combined with slip clutch system
- Load Chain Construction : Alloy Steel Material AISI15B24 Galvanize Coating.
- Hoist Lifting Speed : Variable Lifting Speed Control
- Electric Power Supply : AC 1Ph. 220V. 50Hz.
- Operation Method : Via Control Cable with Push Button Switch and Emergency Stop
- Upper & Lower Protection : Safety Slipping Clutch
- Chain Bucket : Plastic Box
- Main Body and Reducer Case : Aluminum Super Light Weight (14kg)

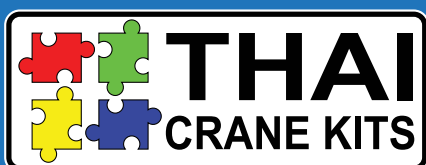

THAI CRANE KITS CO., LTD.

บริษัท ไทยเครนคิทส์ จำกัด

1/19 หมู่ 1 ต.พิมพา อ.บางปะกง จ.ฉะเชิงเทรา 24130 (ประเทศไทย)

มือถือ : 081-867-0435 โทรศัพท์ : 038 989 378-80 แฟกซ์ : 038 989 381

อีเมลล์ : thaicranekits@hotmail.com, thaicranekits.info@gmail.com