

TITAN[®]

SERVICE

TITAN SERVICE CO.,LTD.



“TITAN” CONDUCTOR BAR SYSTEMS

3 Pole 75 Amp, 100 Amp

4 Pole 75 Amp, 100 Amp

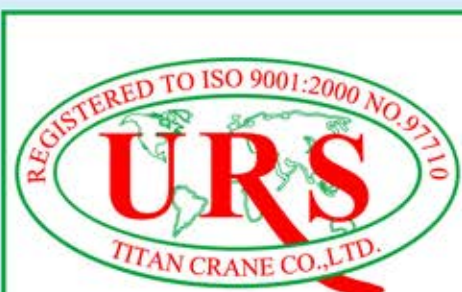

ISO 9001:2000

3 Pole Titan Conductor Bar

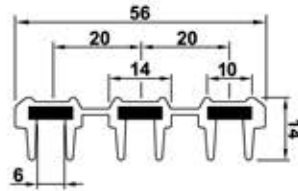

3P. "TITAN" Conductor Bar			
Order No.	Intensity	long	Weight (Kg.)
1-032-0001	75A	1 M.	0.82
1-032-0002	100A	1 M.	1.07

Material : PVC., Copper

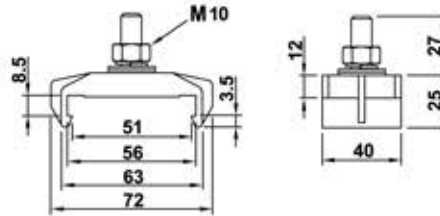

3P. Hanger Clamp		
Order No.	References	Weight (Kg.)
1-032-0003	75Amp, 100Amp	0.07

Material : PVC., Copper

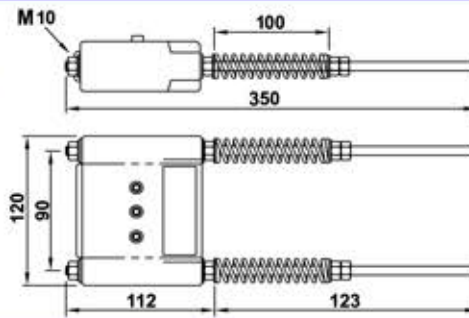

3P. End Tension And Power Feed In		
Order No.	References	Weight (Kg.)
1-032-0004	75A, 100A	1.38

Material : PVC., Steel, Copper

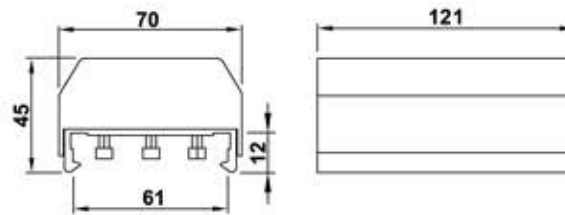

3P. Joint Middle Power Feed In		
Order No.	References	Weight (Kg.)
1-032-0005	100A	0.23

Material : PVC., Steel, Copper

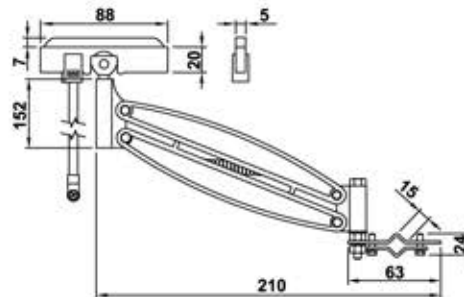

3P. Current Collector		
Order No.	Intensity	Weight (Kg.)
1-032-0006	60A	0.20

Material : PVC., Steel, Copper

Collector Shoe

Order No.	Intensity	Weight (Kg.)
1-032-0013	60A	0.10

Material : PVC., Copper

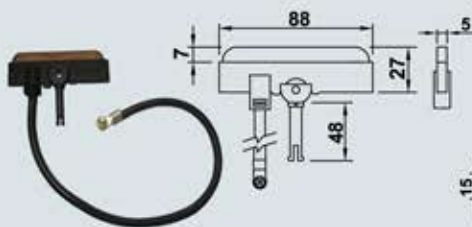

Fix Square Bar

Order No.	Max.Load	Weight (Kg.)
1-032-0014	16 Kg.	0.80

Material : Galvanized Steel

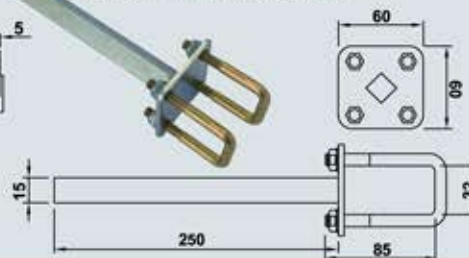

Rectengular Pipe

Order No.	Max.Load	Weight (Kg.)
2-220-0013	750	1.2

Material : Galvanized Steel



4 Pole Titan Conductor Bar

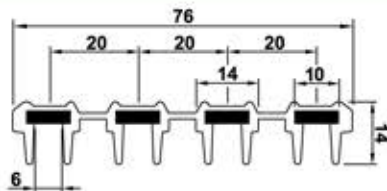

4P. "TITAN" Conductor Bar			
Order No.	Intensity	Long	Weight (Kg.)
1-032-0007	75A	1 M.	1.00
1-032-0008	100A	1 M.	1.20

Material : PVC., Copper

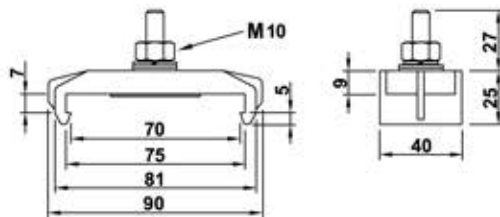

4P. Hanger Clamp		
Order No.	References	Weight (Kg.)
1-032-0009	75A, 100A	0.075

Material : PVC., Steel

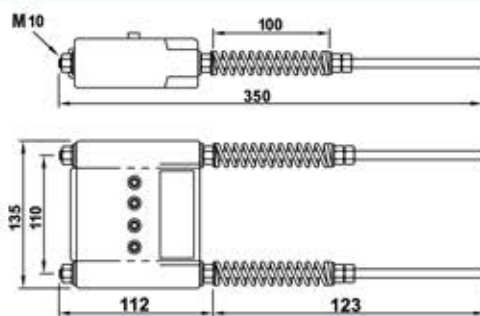

4P. End Tension And Power Feed In		
Order No.	Intensity	Weight (Kg.)
1-032-0010	75A, 100A	1.54

Material : PVC., Steel, Copper

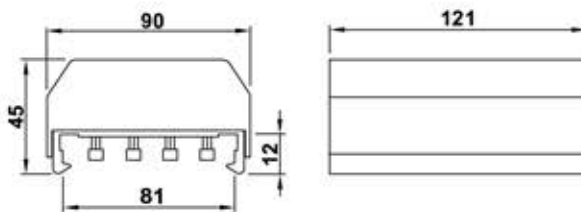

4P. Joint Middle Power Feed In		
Order No.	Intensity	Weight (Kg.)
1-032-0011	75A, 100A	0.35

Material : PVC., Steel, Copper

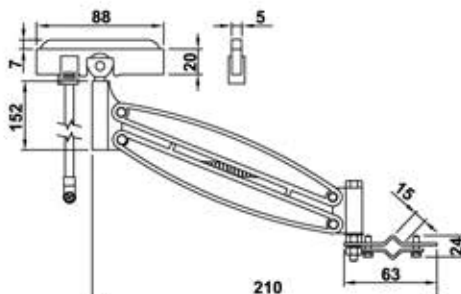

4P. Current Collector		
Order No.	Intensity	Weight (Kg.)
1-032-0012	75A, 100A	1.05

Material : PVC., Steel, Copper



Fix Square Bar		
Order No.	Max.Load	Weight (Kg.)
2-220-0014	20 Kg.	0.021

Material : Galvanized Steel

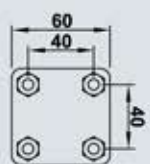
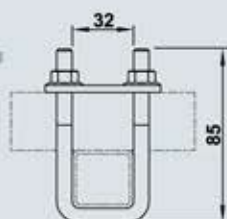

Current Collector Towing Arm				
Order No.	End Carriage	Dimension		Weight (Kg.)
		(A)	(B)	
3-230-0005	250 -500	270 mm.	130 mm.	2.5
3-230-0006	110 -200	270 mm.	130 mm.	2.1

Material : Galvanized Steel

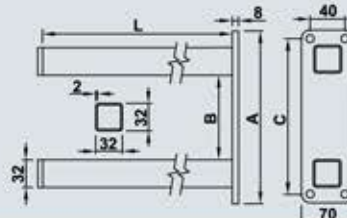

End Carriage Type : 110 - 200 L = 400 mm.
 End Carriage Type : 250 - 500 L = 500 mm.
 Dimension Type : 110 - 200 C = 400 mm.
 Dimension Type : 250 - 500 L = 500 mm.

Assembly Instruction

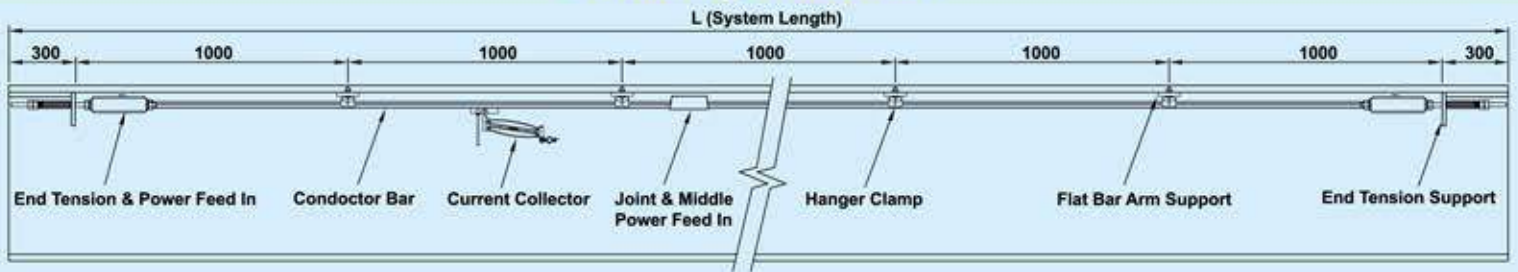

“Titan Conductor Bar Designed Accessories For Support

1. Current Collector Towing Arm
2. Rectangular Pipe
3. Rectangular Pipe Clamp
4. Fix Square Bar

5. Flat Bar Arm
6. Angle Support
7. C-track Arm
8. Welded Rail Support

9. Fastening Bracket
10. Hanger Clamp
11. Current Collector

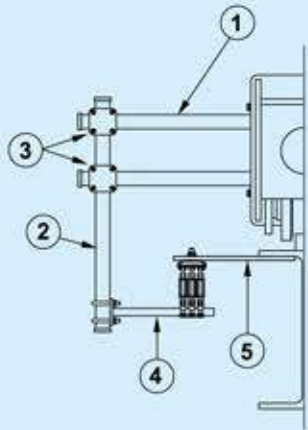

Fix Invert Line

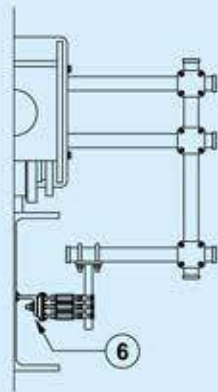

Fix Side Line

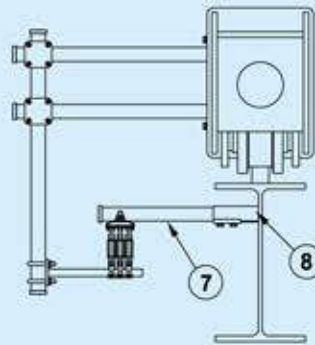

Adjustable Invert Line

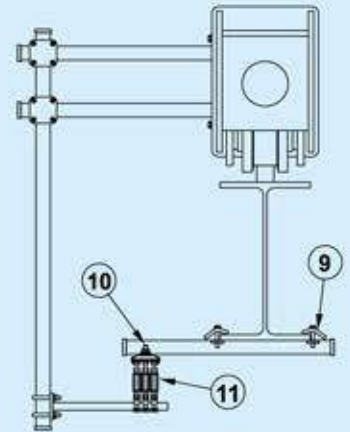

Slideline Support Invert Line

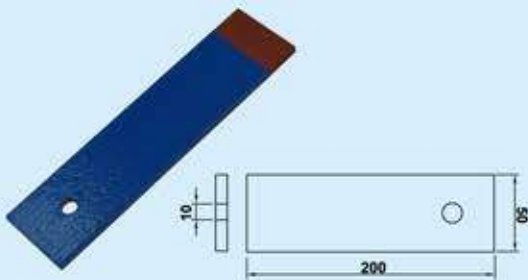

Flat Bar Arm Support		
Order No.	Length (L)	Weight (Kg.)
3-230-0001	200	0.48 Kg.

Material : Steel

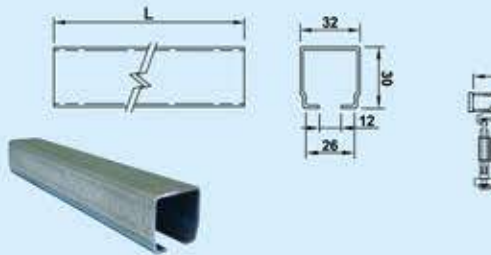

C-Track Arm Support	
Order No.	Max. Load
2-220-0020	16 Kg.

Material : Galvanized Steel

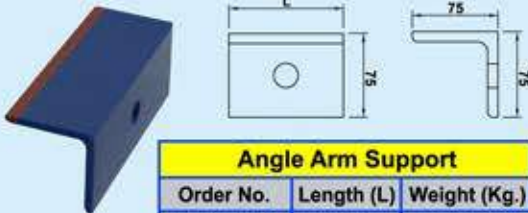
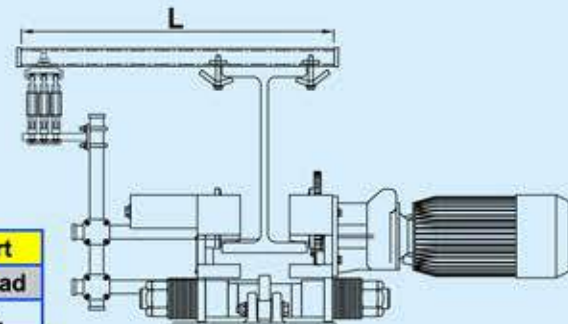

Angle Arm Support		
Order No.	Length (L)	Weight (Kg.)
3-230-0015	100	0.99 Kg.

Material : Steel

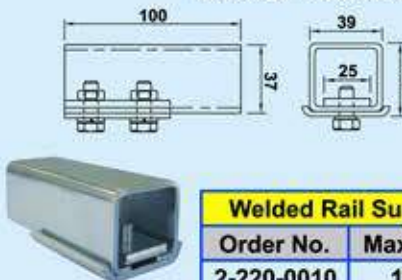

Welded Rail Support	
Order No.	Max. Load
2-220-0010	16 Kg.

Material : Galvanized Steel



Fastening Bracket	
Order No.	Length (mm.)
1-030-0043	400
1-030-0044	500
1-030-0045	600

Material : Galvanized Steel



บริษัท ไทแทน เซอร์วิส จำกัด

1/19 หมู่ 1 ต.พิมพา อ.บางปะกง จังหวัด ฉะเชิงเทรา 24180 ประเทศไทย TAX ID 0245554000604

TEL.038-989-373 ถึง 76 FAX.038-989-377 LINE : @titanservice

Email : info.titanservice@gmail.com Website : www.titanservice.co.th

Facebook.com/Titanservicecompany