



True Union Industrial 3-Way Full Port Ball Valves



Quick-View Valve Selection Chart
3-Way Vertical Full Port Ball Valve

Valve Size	O-ring Material	PVC Part Number ^{1, 2, 3, 4}				Pressure Rating
		Socket	SR Threaded	Flanged	Spigot	
1/2	EPDM	7122L1-005	7121L1-005SR	7123L1-005	7127L1-005	235 psi Non-Shock Water @ 73°F (Flanged 150 psi Non-Shock) Water @ 73°F
	FKM	7132L1-005	7131L1-005SR	7133L1-005	7137L1-005	
3/4	EPDM	7122L1-007	7121L1-007SR	7123L1-007	7127L1-007	
	FKM	7132L1-007	7131L1-007SR	7133L1-007	7137L1-007	
1	EPDM	7122L1-010	7121L1-010SR	7123L1-010	7127L1-010	
	FKM	7132L1-010	7131L1-010SR	7133L1-010	7137L1-010	
1-1/4	EPDM	7122L1-012	7121L1-012SR	7123L1-012	7127L1-012	
	FKM	7132L1-012	7131L1-012SR	7133L1-012	7137L1-012	
1-1/2	EPDM	7122L1-015	7121L1-015SR	7123L1-015	7127L1-015	
	FKM	7132L1-015	7131L1-015SR	7133L1-015	7137L1-015	
2	EPDM	7122L1-020	7121L1-020SR	7123L1-020	7127L1-020	
	FKM	7132L1-020	7131L1-020SR	7133L1-020	7137L1-020	

1: For CPVC valve, add the letter "C" to the part number (e.g. 7122L1-005C)
 2: For Double L-Port, add the number "2" to the part number (e.g. 7122L2-005)
 3: For Triple L-Port, add the number "3" to the part number (e.g. 7122L3-005)
 4: For T-Port, add the letter "T" to the part number (e.g. 7122T1-005)

Quick-View Valve Selection Chart
3-Way Horizontal Full Port Ball Valve

Valve Size	O-ring Material	PVC Part Number ^{1, 2}				Pressure Rating
		Socket	SR Threaded	Flanged	Spigot	
1/2	EPDM	7022L1-005	7021L1-005SR	7023L1-005	7027L1-005	235 psi Non-Shock Water @ 73°F (Flanged 150 psi Non-Shock) Water @ 73°F
	FKM	7032L1-005	7031L1-005SR	7033L1-005	7037L1-005	
3/4	EPDM	7022L1-007	7021L1-007SR	7023L1-007	7027L1-007	
	FKM	7032L1-007	7031L1-007SR	7033L1-007	7037L1-007	
1	EPDM	7022L1-010	7021L1-010SR	7023L1-010	7027L1-010	
	FKM	7032L1-010	7031L1-010SR	7033L1-010	7037L1-010	
1-1/4	EPDM	7022L1-012	7021L1-012SR	7023L1-012	7027L1-012	
	FKM	7032L1-012	7031L1-012SR	7033L1-012	7037L1-012	
1-1/2	EPDM	7022L1-015	7021L1-015SR	7023L1-015	7027L1-015	
	FKM	7032L1-015	7031L1-015SR	7033L1-015	7037L1-015	
2	EPDM	7022L1-020	7021L1-020SR	7023L1-020	7027L1-020	
	FKM	7032L1-020	7031L1-020SR	7033L1-020	7037L1-020	

1: For CPVC valve, add the letter "C" to the part number (e.g. 7022L1-005C)
 2: For T-Port, add the letter "T" to the part number (e.g. 7022T1-005)

Suitable for Oil-Free air handling to 25 psi, not for distribution of compressed air or gas
 See Spears® Product Sourcebook for product offerings

Spears® Manufacturing Company

Valves Technical

True Union Industrial 3-Way Full Port Ball Valves



Features — PVC, CPVC

Versatile Full-Port design provides full flow capability through this multiple port 3-way valve with configuration options for controlling flow distribution in industrial and chemical processing applications. Choose Full-Port Vertical 3-Way or Full-Port Horizontal 3-way with branch shutoff. Valves are available in IPS sizes 1/2" through 2" with socket, SR threaded (Special Reinforced), flanged or spigot end connectors.

- Chemical & Corrosion Resistant PVC or CPVC Construction
- Vertical 3-Way or Horizontal Design
- L-Port, Multi L-Port & T-Port with increased Ball Configuration Options, including special mixing configurations
- High Impact Polypropylene Handle
- Built-in Handle Lockout
- Strong, Buttress Thread Union Nuts
- Spears® Double O-ring Safe-T-Shear® Stem Design
- EPDM or FKM O-rings
- Spears® Safe-T-Blocked® Seal Carrier
- Self Adjusting PTFE Floating Seat Design
- Fully Serviceable, Replaceable Components
- Sizes 1/2" - 2" pressure rated to 235 psi @ 73°F
- All Flanged Pressure Rated to 150 psi @ 73°F
- EPDM Valves NSF® Certified for Potable Water use
- Suitable for Vacuum Service
- Assembled with Silicone-Free, Water Soluble Lubricants
- Manufactured to ASTM F 1970
- Metric Socket and BSP Thread Available

3-Way Port Options

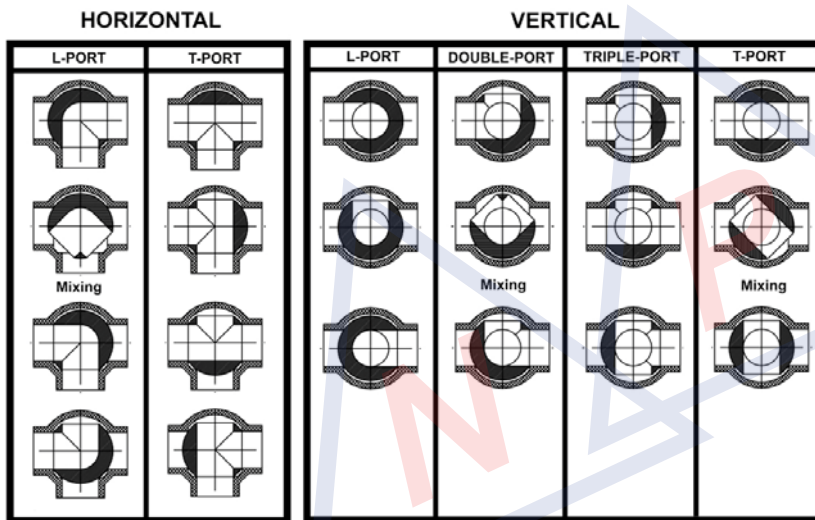

Optional Accessories*

- Retro-Fit End Connector Sets for Valve Replacement
- Split-Nut Repair Kits for Union Nut Replacement
- Supplemental End Connectors
- Stem Extension Kits
- Square Operator Nuts
- Multi Mount Valve/Actuation Mounting Kits
- Adjustable Stop Ring for Mixing Port Options

* See **"BALL VALVE ACCESSORIES"** section for details of individual products.

The Adjustable Stop Ring (sold separately) must be used with any "MIXING" Port Option to provide proper mid-way handle stop function.

Ball Port Options viewed from top of valve.

Sample Engineering Specification

All thermoplastic ball valves shall be True Union Industrial 3-Way Full Port Ball Valves [specify horizontal or vertical] type with [specify port option] manufactured to ASTM F 1970 and constructed from PVC Type I, ASTM D 1784 Cell Classification 12454, or CPVC Type IV, ASTM D 1784 Cell Classification 23447. All O-rings shall be EPDM or FKM. All valves shall have Safe-T-Shear® stem with double O-ring stem seals. All valve handles shall be polypropylene with built-in lockout mechanism. All valve union nuts shall have Buttress threads. All seal carriers shall be Safe-T-Blocked®. All valve components shall be replaceable. All EPDM valves shall be certified by NSF International for use in potable water service. All PVC and CPVC 1/2" through 2" valves shall be pressure rated to 235 psi, all flanged valves shall be pressure rated to 150 psi for water at 73°F as manufactured by Spears® Manufacturing Company.



Valves Technical
True Union Industrial 3-Way Full Port Ball Valves

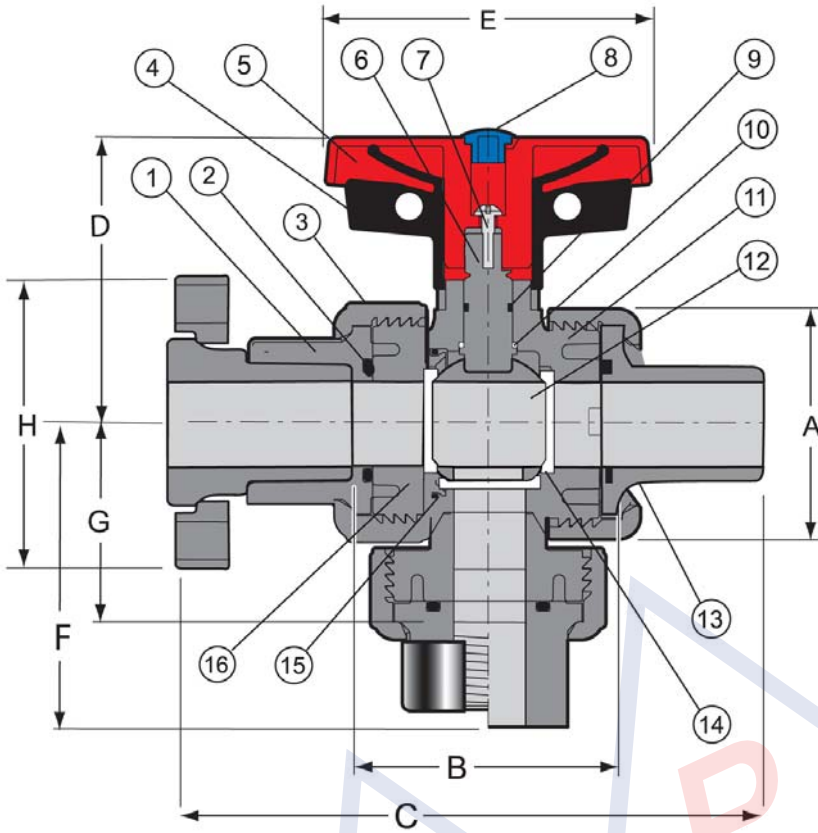

Replacement Parts

No.	Component	Qty.	Material
1	End Connector	3	PVC/CPVC
2	End Connector O-ring	3	EPDM/FKM
3	Union Nut	3	PVC/CPVC
4	Handle Lock	1	PP
5	Handle	1	PP
6	Stem	1	PVC/CPVC
7	Screw	1	Stainless Steel
8	Handle Cover	1	PP
9	Stem O-ring	2	EPDM/FKM
10	Stem Bearing	1	PTFE
11	Body	1	PVC/CPVC
12	Ball	1	PVC/CPVC
13	End Connector Collar	3	Stainless Steel
14	Seat	3	PTFE
15	Carrier O-ring	3	EPDM/FKM
16	Seal Carrier	3	PVC/CPVC

Vertical 3-Way Full Port Ball Valves — Dimensions & Operating Torque

Vertical 3-Way Ball Valve															Oper. ² Torque (in. lbs.)
Nominal Size	A	B ¹		C			D	E	F			G		H	
		Soc/SR Thd	Spigot	Socket	SR Thd	Spigot			Socket	SR Thread	Spigot	Soc/SR Thd	Spigot		
1/2	2-1/8	3-5/8	4-1/8	5-3/8	5	5-7/8	2-5/8	2-13/16	2-11/16	2-1/2	2-15/16	1-13/16	2-11/16	3-1/2	12
3/4	2-9/16	4-1/4	4-3/4	6-1/4	5-3/4	6-3/4	3	3-3/8	3-1/8	2-7/8	3-3/8	2-1/8	2-3/8	3-7/8	12
1	2-7/8	4-1/2	5	6-3/4	6-3/8	7-3/8	3-3/16	3-7/16	3-1/8	3-3/16	3-11/16	2-1/2	2-1/2	4-1/4	20
1-1/4	3-9/16	5-3/4	6-1/4	8-1/8	7-5/8	8-3/4	3-3/4	3-7/8	4-1/16	3-3/4	4-3/8	2-13/16	3-1/8	4-5/8	25
1-1/2	4	6-1/4	6-5/8	9-1/16	8-1/8	9-1/2	4-3/16	4-1/4	4-1/2	4-1/16	4-3/4	3-1/8	3-5/16	5	40
2	4-5/8	7-5/16	8-1/16	10-11/32	9-1/4	10-3/4	4-9/16	5-3/32	5-1/4	4-5/8	5-3/8	3-23/32	3-7/8	6	67

1: Valve Lay Length

2: Torque required at valve maximum internal pressure rating, 5ft/sec. Flow velocity; due to adjustment differences during installation, actual values may vary.

Suitable for Oil-Free air handling to 25 psi, not for distribution of compressed air or gas
 See Spears® Product Sourcebook for product offerings

Spears® Manufacturing Company

Valves Technical
True Union Industrial 3-Way Full Port Ball Valves

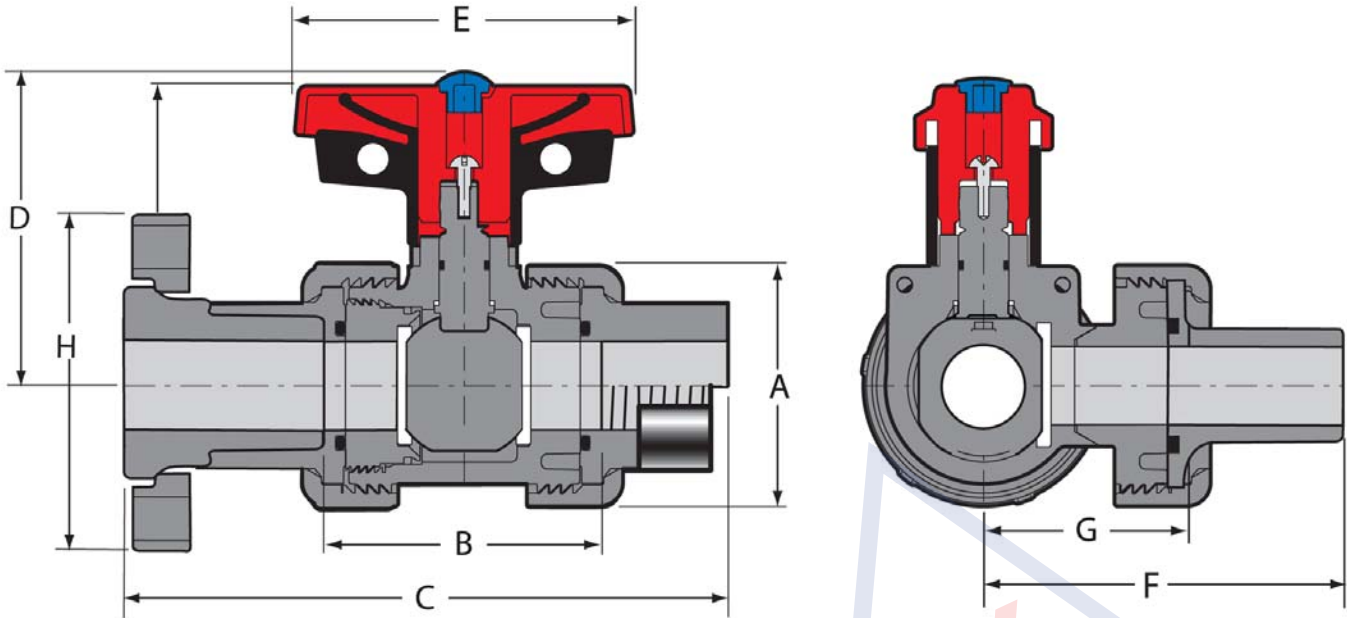

Horizontal 3-Way Full Port Ball Valves Dimensions & Operating Torque

Nominal Size	A	B ¹		C			D	E	F			G		H	Oper. ² Torque (in. lbs.)
		Soc/SR Thread	Spigot	Socket	SR Thread	Spigot			Socket	SR Thread	Spigot	Soc/SR Thread	Spigot		
1/2	2-1/8	3-5/8	4-1/8	5-3/8	5	5-7/8	2-5/8	2-13/16	2-11/16	2-1/2	2-15/16	1-13/16	2-1/16	3-1/2	12
3/4	2-9/16	4-1/4	4-3/4	6-1/4	5-3/4	6-3/4	3	3-3/8	3-1/8	2-7/8	3-3/8	2-1/8	2-3/8	3-7/8	12
1	2-7/8	4-1/2	5	6-3/4	6-3/8	7-3/8	3-3/16	3-7/16	3-3/8	3-3/16	3-11/16	2-1/2	2-1/2	4-1/4	20
1-1/4	3-9/16	5-3/4	6-1/4	8-1/8	7 5/8	8-3/4	3-3/4	3-7/8	4-1/16	3-3/4	4-3/8	2-13/16	3-1/8	4-5/8	25
1-1/2	4	6-5/16	6-5/8	9-1/16	8-1/8	9-1/2	4-3/16	4-1/8	4-1/2	4-1/16	4-3/4	3-1/8	3-5/16	5	40
2	4-5/8	7-3/8	8-1/16	10-3/8	9-1/4	10-3/4	4-9/16	5-3/32	5-1/8	4-5/8	5-3/8	3-5/8	3-7/8	6	67

1: Valve Lay Length

2: Torque required at valve maximum internal pressure rating, 5ft/sec. Flow velocity; due to adjustment differences during installation, actual values may vary.

Temperature Pressure Rating

System Operating Temperature °F (°C)			100 (38)	110 (43)	120 (49)	130 (54)	140 (60)	150 (66)	160 (71)	170 (77)	180 (82)	190 (88)	200 (93)	210 (99)
Valve Pressure Rating psi (MPa)	1/2" - 2"	PVC	235 (1.62)	211 (1.45)	150 (1.03)	75 (.52)	50 (.34)	-0- (-0-)	-0- (-0-)	-0- (-0-)	-0- (-0-)	-0- (-0-)	-0- (-0-)	-0- (-0-)
		CPVC	235 (1.62)	219 (1.51)	170 (1.17)	145 (1.00)	130 (.90)	110 (.76)	90 (.62)	80 (.55)	70 (.48)	60 (.41)	50 (.34)	-0- (-0-)

Note: Flanged Valves have a base pressure rating of 150 psi.