

Valves Technical  
**Compact 2000 Ball Valves**



**Features — PVC, CPVC**

Economical, low profile quarter-turn shutoff valve is excellent for general purpose and many O.E.M applications. PVC and CPVC valves are available in IPS sizes 1/2" through 2" with socket, regular thread and flanged.

- Industrial Grade, Maintenance-Free Sealed Unit
- New Actuator-Ready Body — Accepts Spears® Improved Mini-Mount Actuator Mounting Kits
- New Double O-ring Stem Seal
- Schedule 80 Full-Port Design
- Spears® Safe-T-Shear Stem
- PTFE Self Adjusting Floating Seats
- EPDM or FKM O-ring Seals
- Full 235 psi PPressure Rating @ 73°F
- EPDM valves NSF® Certified for Use with Potable Water
- Suitable for Vacuum Service
- Produced in ASTM IPS sizes 1/2" - 2" with Socket, Threaded or Flanged End Connectors.

**Sample Engineering Specification**

All thermoplastic ball valves shall be 2000 Compact sealed unit type manufactured to ASTM F 1970 and constructed from PVC Type I, ASTM D 1784 Cell Classification 12454 or CPVC Type IV, ASTM D 1784 Cell Classification 23447. All O-rings shall be EPDM or FKM. All valves shall have Safe-T-Shear® stem with O-ring stem seal. All handles shall be polypropylene. All EPDM valves shall be certified by NSF International for use with potable water. All 1/2" - 2" valves shall be pressure rated to 235 psi and all flanged valves shall be pressure rated at 150 psi for water @ 73°F, as manufactured by Spears® Manufacturing Company.

**Optional Accessories\***

- Round Safety Handles
- Stem Extension Kits
- Square Operator Nuts
- Multi Mount Valve/Actuation Mounting Kits
- Mini-Mount Actuation Mounting Kits

\* See **"BALL VALVE ACCESSORIES"** section for details of individual products.

**Quick-View Valve Selection Chart**

Valve Size	O-ring Material	PVC Part Number <sup>1</sup>			Pressure Rating
		Socket	Threaded	Flanged	
1/2	EPDM	6622-005	6621-005	6623-005	235 psi Non-Shock Water @73°F  (Flanged 150 psi Non-Shock) Water @73°F
	FKM	6632-005	6631-005	6633-005	
3/4	EPDM	6622-007	6621-007	6623-007	
	FKM	6632-007	6631-007	6633-007	
1	EPDM	6622-010	6621-010	6623-010	
	FKM	6632-010	6631-010	6633-010	
1-1/4	EPDM	6622-012	6621-012	6623-012	
	FKM	6632-012	6631-012	6633-012	
1-1/2	EPDM	6622-015	6621-015	6623-015	
	FKM	6632-015	6631-015	6633-015	
2	EPDM	6622-020	6621-020	6623-020	
	FKM	6632-020	6631-020	6633-020	

1: For CPVC Valves, add the letter "C" to part numbers listed. (e.g., 6622-005C)



## Valves Technical Compact 2000 Ball Valves

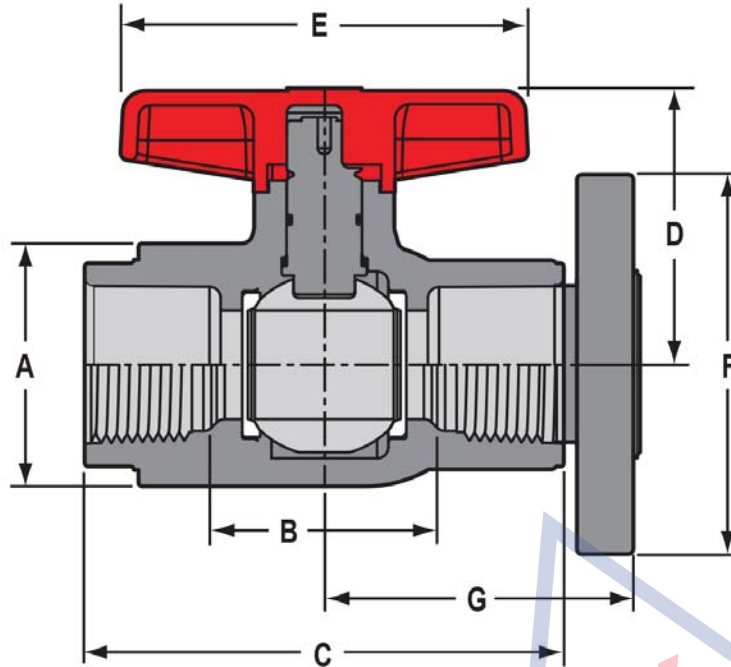

### Dimensions, Weights, Operating Torque & C<sub>v</sub> Values

Nominal Size	Dimension Reference (inches, ± 1/16)								Approx. Wt. (Lbs.)		Oper. <sup>2</sup> Torque (in.-lb.)	C <sub>v</sub> <sup>3</sup> Values
	A	B <sup>1</sup>		C	D	E	F	G	PVC	CPVC		
		Socket	Threaded									
1/2	1-7/16	1-1/4	1-1/2	3	1-5/8	2-1/2	3-1/2	2-11/32	.18	.20	10	42
3/4	1-3/4	1-1/2	2	3-1/2	2	3	3-7/8	2-5/8	.29	.31	20	87
1	2-1/16	1-11/16	2-3/16	3-15/16	2-5/16	3-3/8	4-1/4	2-29/32	.44	.46	25	157
1-1/4	2-9/16	2-1/8	2-3/4	4-5/8	2-13/16	3-1/2	4-5/8	3-9/32	.68	.70	30	311
1-1/2	2-15/16	2-1/2	3-5/16	5-1/4	3-1/16	3-7/8	5	3-27/32	.99	1.03	50	429
2	3-9/16	3	4	6	3-3/4	4-15/16	5-7/8	4-1/4	1.64	1.70	90	768

1: Valve Lay Length

2: Torque required at valve maximum internal pressure rating, 5ft/sec. Flow velocity.

3: Gallons per minute at 1 psi pressure drop. Valves calculated from laying length, based on derivative of Hazen-Williams equation with surface roughness factor of C=150.

### Temperature Pressure Rating

System Operating Temperature °F (°C)			100 (38)	110 (43)	120 (49)	130 (54)	140 (60)	150 (66)	160 (71)	170 (77)	180 (82)	190 (88)	200 (93)	210 (99)
Valve Pressure Rating psi (MPa)	1/2" - 2"	PVC	235 (1.62)	211 (1.45)	150 (1.03)	75 (.52)	50 (.34)	-0 (-0)	-0 (-0)	-0 (-0)	-0 (-0)	-0 (-0)	-0 (-0)	-0 (-0)
		CPVC	235 (1.62)	219 (1.51)	170 (1.17)	145 (1.00)	130 (.90)	110 (.76)	90 (.62)	80 (.55)	70 (.48)	60 (.41)	50 (.34)	-0 (-0)
	Flanged	PVC	150 (1.03)	135 (.93)	110 (.76)	75 (.52)	50 (.34)	-0 (-0)	-0 (-0)	-0 (-0)	-0 (-0)	-0 (-0)	-0 (-0)	-0 (-0)
		CPVC	150 (1.03)	140 (.97)	130 (.90)	120 (.83)	110 (.76)	100 (.70)	90 (.62)	80 (.55)	70 (.48)	60 (.41)	50 (.34)	-0 (-0)

Suitable for Oil-Free air handling to 25 psi, not for distribution of compressed air or gas

See Spears® Product Sourcebook for product offerings