

Hitachi Hoists

Electric Chain Hoist



HITACHI Electric Chain Hoist

Widely used to make cargo handling more efficient.

A wide range of applications are provided for not only general machinery, automobile, can manufacturing and other plants but also for applications from primary to tertiary industries including warehouses and retail stores.



Contents

● Introduction ————— 1-2

Outline

● List of Model Series ————— 3

● Standard Specifications ————— 4

● Model Explanation ————— 4

● Series Selection ————— 4

● Operating Conditions and Model Selection Method — 5

● Standard Specifications Quick Reference ————— 6

● Features

Standard Model ————— 7-8

CE Marking Model ————— 9-10

S series

■ Suspension type ————— 11-12

● With motorized trolley - ET ————— 13

● With motorized trolley - ST ————— 14

● With chain driven trolley - BC ————— 15

● With manual driven trolley - BP ————— 16

F series

● Suspension type ————— 17-18

● With motorized trolley - ET ————— 19

● With motorized trolley - ST ————— 20

● With chain driven trolley - BC ————— 21

● With manual driven trolley - BP ————— 22

Others

● Crane wiring unit ————— 23

● Dedicated electric chain hoist ————— 24-26

● Technical materials ————— 26

Outline

S series

F series

Others

S series Suitable for general work. Economical standard speed model.

(P11-P16)

	Rated load	250kg	500kg	1t	2t	3t	5t	10t	15t	20t
Single speed model : S		●		●						
Dual speed model : SN		●		●						
Single phase model : SS, S1		●		●						

F series High-speed model that is sturdy and suitable for high-speed work.

(P17-P22)

	Rated load	250kg	500kg	1t	2t	3t	5t	10t	15t	20t
Single speed model : F				●	●					
Dual speed model : FN				●	●					

Trolley series

	Rated load	250kg	500kg	1t	2t	3t	5t	10t	15t	20t
Motorized trolley-ET series Single speed model : ET		●		●	●	●	●	5ET×2	7.5ET×2	10ET×2
Motorized trolley-ST series Single speed model : ST				●	●	●				
Chain driven trolley : BC		●		●	●	●				
Manual driven trolley : BP		●		●						

Dedicated electric chain hoist contents

- Twin hook type electric chain hoist ———— 24
- Low head room type ———— 25
- Optional power source electric chain hoist and trolley — 25
- Optional control voltage model ———— 25
- Electric chain hoist with the Hi-plated chain ——— 25
- Electric chain hoist with overload prevention unit (with OL) — 25
- With geared limit switch (UDS) ———— 25
- Other products with changed specifications
Lift change (extension), etc. ———— 25-26

Standard Specifications

Specifications		Standard model	CE Making model	
Power Source*	50Hz	3 phase : 220/380-415V 3 phase : 346-380V 1 phase : 200-220V	1 phase : 220-240V	
	60Hz	3 phase : 220V, 220-230/440-460V 1 phase : 110V, 220V	—	
Operation Method	Operating pushbutton			
Control Voltage	24V			
Power Method	Suspension type with manual driven trolley or chain driven trolley : with 5m cable With motorized trolley : cable and catch are not included with standard shipment			
Pushbutton Switch	2(3)	single speed	↑ ↓	(STOP) ↑ ↓
		dual speed	↑ ↓	(STOP) ↑ ↓
	4(5)	single speed	↑ ↓ ← →	(STOP) ↑ ↓ ← →
		dual speed	↑ ↓ ← →	(STOP) ↑ ↓ ← →
	6(7)	single speed	↑ ↓ ← → ↻	(STOP) ↑ ↓ ← → ↻
		dual speed	↑ ↓ ← → ↻	(STOP) ↑ ↓ ← → ↻
Color(Munsell)	Orange(2.5YR 6/12)			
Electrical Protection	IP54(S-series(1t and above),Trolley : IP44) (Equivalent when stuffing drain hole)			
Insulation Class of Motor	E			
Rating**	30%ED, 180starts/h(1 to 5S : 25%ED, 150starts/h)			
Classification	ISO M4, FEM 1Am			
Standards	—	Machinery : 98/37/EC EMC : 89/336/EEC, 92/31/EEC, 93/68/EEC		

* For power sources other than those listed, see the dedicated electric chain hoists (page25).
 ** This shows the value at a load of 63% of the rated load.
 ** Make sure the average value per hour is not exceeded even during concentrated use in a short time.
 ** Dual speed models have an added low speed to allow fine movement operation and improve workability by reducing inching. The rating shows the value when the high speed and the low speed, the operation time of which is 1/10 of the high speed, are combined.

Series Selection

When selecting an electric chain hoist, the operating environment, operating time, and operating frequency must be taken into consideration.

Operating time and load ratio

Use within the range of section.

Load Condition	Load Ratio	Mean operating hour per day (h)					
		0.25	0.5	1	2	4	8
Light	$K \leq 0.5$						
Medium	$0.5 < K \leq 0.63$						
Heavy	$0.63 < K \leq 0.8$				S, Fseries		
Severe	$0.8 < K$						

Load condition
 Light : This is normally used at a load of 1/2 the rated load, and on rare occasions at the rated load.
 Medium : This is normally used at a load of 1/2 to 2/3 the rated load, and occasionally at the rated load.
 Heavy : This is normally used at loads above 2/3 the rated load, and often at the rated load.
 Severe : This is mostly used at the rated load or close to this load.

* If use is expected to exceed the above range, then an electric chain hoist with a higher capacity must be selected, so please consult with HITACHI.

Operating environment

- Use in locations with an ambient temperature of -10°C to 40°C (with no freezing) and humidity of 90% or less (no condensation).

Model Explanation

● For suspension types

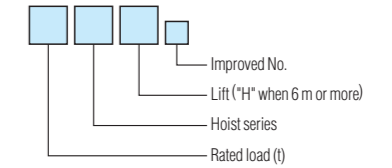

Ex. 2t, S series, Lift 6m

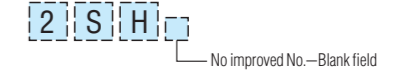

● For with trolley

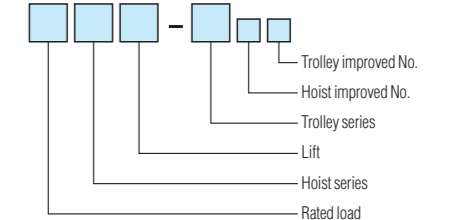

Ex. 1t, SN series, Lift 3m, With motorized trolley-ET

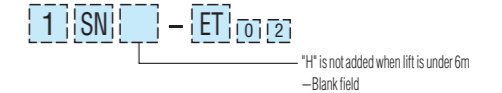

* Separate product name plates are placed on the hoist unit and the trolley unit
 Ex. 1SN-ET: Hoist unit name plate "1SN" / Trolley unit name plate "1ET"

In addition to the general specifications, (1) starting frequency, (2) duty factor, and (3) load ratio must be taken into consideration.

● Calculation method (If the calculated value exceeds the standard specification, then it is a dedicated specification.)

(1) Max. starting frequency α (Starts/h) = $2 \times n \times N$
 ● Example calculation
 The starting frequency is the cumulative sum of the inching operation count, so this must be calculated by estimating the number of inchings per hoist round trip.

$$2 \times 3 \times 25 = 150 \text{ Starts/h}$$
 Lifting+Lowering (Number of times) Inching count (times) per lifting or lowering operation. No. of transfer per hour (times)

(2) Duty factor β (%) = $\frac{\text{The total motor ON time (minutes) per hour under the most frequent condition.}}{60 \text{ min}} \times 100$

$$= 2 \times \frac{\ell}{V} \times N \times \frac{1}{60 \text{ min}} \times 100$$
 ● Example calculation

$$2 \times \frac{3}{10} \times 25 \div 60 \times 100 = 25\%$$
 Lifting+Lowering (Times) Lifting (m) No. of transfer per hour (Times) 1 hour (60 min) Hoisting speed (m/min)

(3) Load ratio $K = \sqrt[3]{P_1 t_1 + P_2 t_2 + P_3 t_3 + \dots}$
 ● Example calculation
 When a 0.4t load is suspended on a 1-ton rated load electric chain hoist for a one-way trip, with a no-load return trip. (The lifting sling is 0.3t).

$$K = \sqrt[3]{(0.3+0.4)^3 \times 0.5 + 0.3^3 \times 0.5} = 0.57$$
 In this case, the load condition is comparable to "medium" and the average operating time per day is 2 hours or less. If used for a longer time than this, an electric chain hoist with a higher capacity must be selected.

n : Inching count (times) per lifting or lowering operation. t₁, t₂, t₃ : Ratio of the operating time of each load to the total operating time
 N : Transport count (times) within 1 hour
 ℓ : Lift(m)
 V : Hoisting speed(m/min)
 P₁, P₂, P₃ : Each load ratio (ratio of the load to each rated load)

Operating Conditions and Model Selection Method

Select a model from the following that is suitable for the operating conditions.

Operating Conditions		Main Unit	Trolley	Pushbutton Cable	Crane Saddle	Option	
Suspension Type		S series F series P11 P17	—	 Power cable Pushbutton cable			
Manual Driven Trolley Type			BP series P16 P22	 BC series P15 P21	2PB(H) For single speed 2PBN(H) For double speed		
Chain Driven Trolley Type			ET series P13 P20			 ET series P13 P20 * Cables between Main unit and Trolley are not attached	 4PB(H) 4PBN(H)
Motorized Trolley Type				BP series P16 P22	 Wiring unit 4PB(H)-C 4PBN(H)-C	 Crane saddle TL series TLM series TH series THM series SL series SLM series	 Crane girder switch unit (24V operation) GMB-10
Motorized Trolley Motorized Travel Type			BC series P15 P21				
Manual Driven Trolley Motorized Travel Type							
Chain Driven Trolley Motorized Travel Type							

Pushbutton cable

* The operation method is a pushbutton operation. Indirect 24V control voltage.

* A power cable is not included with the trolley. Refer to the Power cable in the list below and prepare a suitable one.

Standard Model

	Type	Lift (m)	Number of Pushbutton Switch	Material of Cable		Pushbutton Switch			
				For Pushbutton Cable	For Power Cable	Character	Contact		
For Single Speed Type	2PB	3	2	T-VCT 3CX0.75mm ²	VCT 4CX2mm ²	Character	↑ ↓		
	2PBH	6				Contact	2a		
	4PB	3	4	T-VCT 5CX0.75mm ²	—	Character	↑ ↓	← →	
	4PBH	6				Contact	2a	2a	
	6PB	3	6	T-VCT 8CX0.75mm ²	—	Character	↑ ↓	← →	↺ ↻
	6PBH	6				Contact	2a	2a	2a
For Dual Speed Type	2PBN	3	2	T-VCT 5CX0.75mm ²	VCT 4CX2mm ²	Character	↑ ↓		
	2PBNH	6				Contact	4a+2b		
	4PBN	3	4	T-VCT 6CX0.75mm ²	—	Character	↑ ↓	← →	
	4PBNH	6				Contact	4a+2b	2a	
	6PBN	3	6	T-VCT 8CX0.75mm ²	—	Character	↑ ↓	← →	↺ ↻
	6PBNH	6				Contact	4a+2b	2a	2a

CE Version

	Type	Lift (m)	Number of Pushbutton Switch	Material of Cable		Pushbutton Switch				
				For Pushbutton Cable	For Power Cable	Character	Contact			
For Single Speed Type	3PBE	3	3	T-VCT 4CX0.75mm ²	VCT 4CX2mm ²	Character	(STOP)	↑ ↓		
	3PBEH	6				Contact	1b	2a		
	5PBE	3	5	T-VCT 7CX0.75mm ²	—	Character	(STOP)	↑ ↓	← →	
	5PBEH	6				Contact	1b	2a	2a	
	7PBE	3	7	T-VCT 8CX0.75mm ²	—	Character	(STOP)	↑ ↓	← →	↺ ↻
	7PBEH	6				Contact	1b	2a	2a	2a
For Dual Speed Type	3PBNE	3	3	T-VCT 5CX0.75mm ²	VCT 4CX2mm ²	Character	(STOP)	↑ ↓		
	3PBNEH	6				Contact	1b	4a+2b		
	5PBNE	3	5	T-VCT 7CX0.75mm ²	—	Character	(STOP)	↑ ↓	← →	
	5PBNEH	6				Contact	1b	4a+2b	2a	
	7PBNE	3	7	T-VCT 9CX0.75mm ²	—	Character	(STOP)	↑ ↓	← →	↺ ↻
	7PBNEH	6				Contact	1b	4a+2b	2a	2a

● Standard Specifications Quick Reference

Hoist main unit

Capacity (kg)	Hoisting Speed (m/min)(50/60Hz)			Motor (kW)(50/60Hz)		Power Source (phase)	Chain		Lift (m)	Type	See page	Function		
	Type	Main	Creep	Main	Creep		Dia. (mm)	No. of falls				Automatic Adjusting Brake	Reverse Phase Inspecting Relay	Auxiliary Brake System
250	Single	10/12	—	0.45/0.55	—	3	6.3	1	3	1/4S ₂	11,12	—	—	—
250	Single	10/12	—	0.45/0.55	—	3	6.3	1	6	1/4SH ₂	11,12	—	—	—
250	Dual	7.2/8.5	1.8/2.1	0.32/0.38	0.08/0.1	3	6.3	1	3	1/4SN ₂	11,12	—	—	—
250	Dual	7.2/8.5	1.8/2.1	0.32/0.38	0.08/0.1	3	6.3	1	6	1/4SNH ₂	11,12	—	—	—
250	Single	5/6	—	0.25/0.3	—	1	6.3	1	3	1/4SS ₂	11,12	—	—	—
250	Single	5/6	—	0.25/0.3	—	1	6.3	1	6	1/4SSH ₂	11,12	—	—	—
500	Single	7.2/8.5	—	0.63/0.75	—	3	6.3	1	3	1/2S ₂	11,12	—	—	—
500	Single	7.2/8.5	—	0.63/0.75	—	3	6.3	1	6	1/2SH ₂	11,12	—	—	—
500	Dual	7.2/8.5	1.8/2.1	0.63/0.75	0.16/0.19	3	6.3	1	3	1/2SN ₂	11,12	—	—	—
500	Dual	7.2/8.5	1.8/2.1	0.63/0.75	0.16/0.19	3	6.3	1	6	1/2SNH ₂	11,12	—	—	—
500	Single	3.6/4.2	—	0.32/0.37	—	1	6.3	1	3	1/2SS ₂	11,12	—	—	—
500	Single	3.6/4.2	—	0.32/0.37	—	1	6.3	1	6	1/2SSH ₂	11,12	—	—	—
1,000	Single	4.6/5.5	—	0.8/1.0	—	3	7.1	1	3	1S	11,12	—	○	—
1,000	Single	4.6/5.5	—	0.8/1.0	—	3	7.1	1	6	1SH	11,12	—	○	—
1,000	Single	7.1/8.5	—	1.3/1.6	—	3	7.1	1	3	1F	17,18	○	○	○
1,000	Single	7.1/8.5	—	1.3/1.6	—	3	7.1	1	6	1FH	17,18	○	○	○
1,000	Dual	4.6/5.5	1.2/1.4	0.8/1.0	0.2/0.25	3	7.1	1	3	1SN	11,12	—	○	—
1,000	Dual	4.6/5.5	1.2/1.4	0.8/1.0	0.2/0.25	3	7.1	1	6	1SNH	11,12	—	○	—
1,000	Single	2.3/2.8	—	0.4/0.5	—	1	7.1	1	3	1S1	11,12	—	—	—
1,000	Single	2.3/2.8	—	0.4/0.5	—	1	7.1	1	6	1SH1	11,12	—	—	—
2,000	Single	2.3/2.8	—	0.8/1.0	—	3	7.1	2	3	2S	11,12	—	○	—
2,000	Single	2.3/2.8	—	0.8/1.0	—	3	7.1	2	6	2SH	11,12	—	○	—
2,000	Single	6.8/8.2	—	2.4/2.9	—	3	10	1	3	2F	17,18	○	○	○
2,000	Single	6.8/8.2	—	2.4/2.9	—	3	10	1	6	2FH	17,18	○	○	○
2,000	Dual	2.3/2.8	0.6/0.7	0.8/1.0	0.2/0.25	3	7.1	2	3	2SN	11,12	—	○	—
2,000	Dual	2.3/2.8	0.6/0.7	0.8/1.0	0.2/0.25	3	7.1	2	6	2SNH	11,12	—	○	—
2,000	Dual	6.8/8.2	1.7/2.0	2.4/2.9	0.6/0.7	3	10	1	3	2FN	17,18	○	○	○
2,000	Dual	6.8/8.2	1.7/2.0	2.4/2.9	0.6/0.7	3	10	1	6	2FNH	17,18	○	○	○
2,000	Single	1.1/1.4	—	0.4/0.5	—	1	7.1	2	3	2S1	11,12	—	—	—
2,000	Single	1.1/1.4	—	0.4/0.5	—	1	7.1	2	6	2SH1	11,12	—	—	—
3,000	Single	1.5/1.8	—	0.8/1.0	—	3	7.1	3	3	3S	11,12	—	○	—
3,000	Single	1.5/1.8	—	0.8/1.0	—	3	7.1	3	6	3SH	11,12	—	○	—
3,000	Single	4.1/4.9	—	2.4/2.9	—	3	10	2	3	3F	17,18	○	○	○
3,000	Single	4.1/4.9	—	2.4/2.9	—	3	10	2	6	3FH	17,18	○	○	○
3,000	Dual	4.0/4.8	1.0/1.2	2.4/2.9	0.6/0.7	3	10	2	3	3FN	17,18	○	○	○
3,000	Dual	4.0/4.8	1.0/1.2	2.4/2.9	0.6/0.7	3	10	2	6	3FNH	17,18	○	○	○
3,000	Single	0.8/0.9	—	0.4/0.5	—	1	7.1	3	3	3S1	11,12	—	—	—
3,000	Single	0.8/0.9	—	0.4/0.5	—	1	7.1	3	6	3SH1	11,12	—	—	—
5,000	Single	0.9/1.1	—	0.8/1.0	—	3	7.1	5	3	5S	11,12	—	○	—
5,000	Single	0.9/1.1	—	0.8/1.0	—	3	7.1	5	6	5SH	11,12	—	○	—
5,000	Single	2.8/3.3	—	2.4/2.9	—	3	10	3	3	5F	17,18	○	○	○
5,000	Single	2.8/3.3	—	2.4/2.9	—	3	10	3	6	5FH	17,18	○	○	○
5,000	Dual	2.8/3.3	0.7/0.8	2.4/2.9	0.6/0.7	3	10	3	3	5FN	17,18	○	○	○
5,000	Dual	2.8/3.3	0.7/0.8	2.4/2.9	0.6/0.7	3	10	3	6	5FNH	17,18	○	○	○
5,000	Single	0.45/0.55	—	0.4/0.5	—	1	7.1	5	3	5S1	11,12	—	—	—
5,000	Single	0.45/0.55	—	0.4/0.5	—	1	7.1	5	6	5SH1	11,12	—	—	—
10,000	Single	2.8/3.3	—	2.4/2.9×2	—	3	10	4	6	10FH	17,18	○	○	○
10,000	Dual	2.8/3.3	0.7/0.8	2.4/2.9×2	0.6/0.7×2	3	10	4	6	10FNH	17,18	○	○	○
15,000	Single	1.8/2.2	—	2.4/2.9×2	—	3	10	6	6	15FH	17,18	○	○	○
15,000	Dual	1.8/2.2	0.45/0.55	2.4/2.9×2	0.6/0.7×2	3	10	6	6	15FNH	17,18	○	○	○
20,000	Single	1.4/1.6	—	2.4/2.9×2	—	3	10	8	6	20FH	17,18	○	○	○

Motorized trolley

Rated Load	Model Name	Traveling Speed(m/min)		Applicable Beam Width (mm)	Min. Curve Radius (m)	Page		
		50Hz	60Hz					
250kg-1t	1ET	21·10.5	25·12.5	75-125	1.5	13, 14 19, 20		
	1ST							
2ET								
2ST								
3ET								
3ST								
2t	2ET	10.5	12.5	100-150	2.5			
2ST								
3ET								
3ST								
5ET								
5ST								
3t	3ET	14	17	125-175	3.0			
3ST								
5ET								
5ST								
10t	5ET×2				175, 190	Straight	150, 175	5.0
15t	7.5ET×2							
20t	10ET×2							

Crane saddle

Model Configuration	Max. Wheel Load (t)	Max. Span (m)	Traveling Speed (m/min)	Model Name	Main Unit Frame Structure
2.8	12	TL ₅ -28			
1	10	TH ₅ -10	Double channel structure (TH ₅ -10, TH ₅ -28 Use uniform thickness channel steel)		
2.8	12	TH ₅ -28			
3	16	TH ₅ -30			
5.6	18	TH ₅ -56			
Suspension Crane Saddle	11.2	20	25/30	TH-112	L-shaped frame structure
	0.6	10		SL-6	
	1	10		SL ₅ -10	
2.8	12	SL ₅ -28			

Chain driven trolley

Rated Load	Model Name	Applicable Beam Width (mm)	Min. Curve Radius (m)
250-500kg	1/2BC(H)	75-125	1.0
1t	1BC(H)		1.2
2t	2BC(H)	100-150	1.5
3t	3BCH		1.5
5t	5BCH	125-175	2.4

Manual driven trolley

Rated Load	Model Name	Applicable Beam Width (mm)	Min. Curve Radius (m)
250-500kg	1/2BP	75-125	1.0
1t	1BP		1.2
2t	2BP	100-150	1.5

Hitachi Electric Chain Hoists are Packed with Advanced Features

STANDARD MODEL S series **S** / F series **F**

HELICAL GEARING **S F**

used where practical to provide quiet operation.

LONG LIFE BRAKE UNIT **S F**

Disk type Electro-Magnetic brake system for steady operation and long life.

AUTOMATIC ADJUSTING BRAKE **F**

are equipped with patented Automatic Adjusting Brake for easier maintenance and added safety.
U.S. PAT. 3908802
Germany PAT. 2354044



ELECTRO-MAGNETIC CONTACTOR **S F**

with mechanical-interlocking against line short by mechanical shock.

POWER CHAIN **S F**

special (patented) alloy steel chain surface hardened for optimum strength and wear resistance.
(U.S. PAT. 3830054)

CHAIN CONTAINER **S F**

as standard part for safer operation.

LOWER HOOK **S F**

is heat-treated and equipped with safety latch and 360° swivelling.

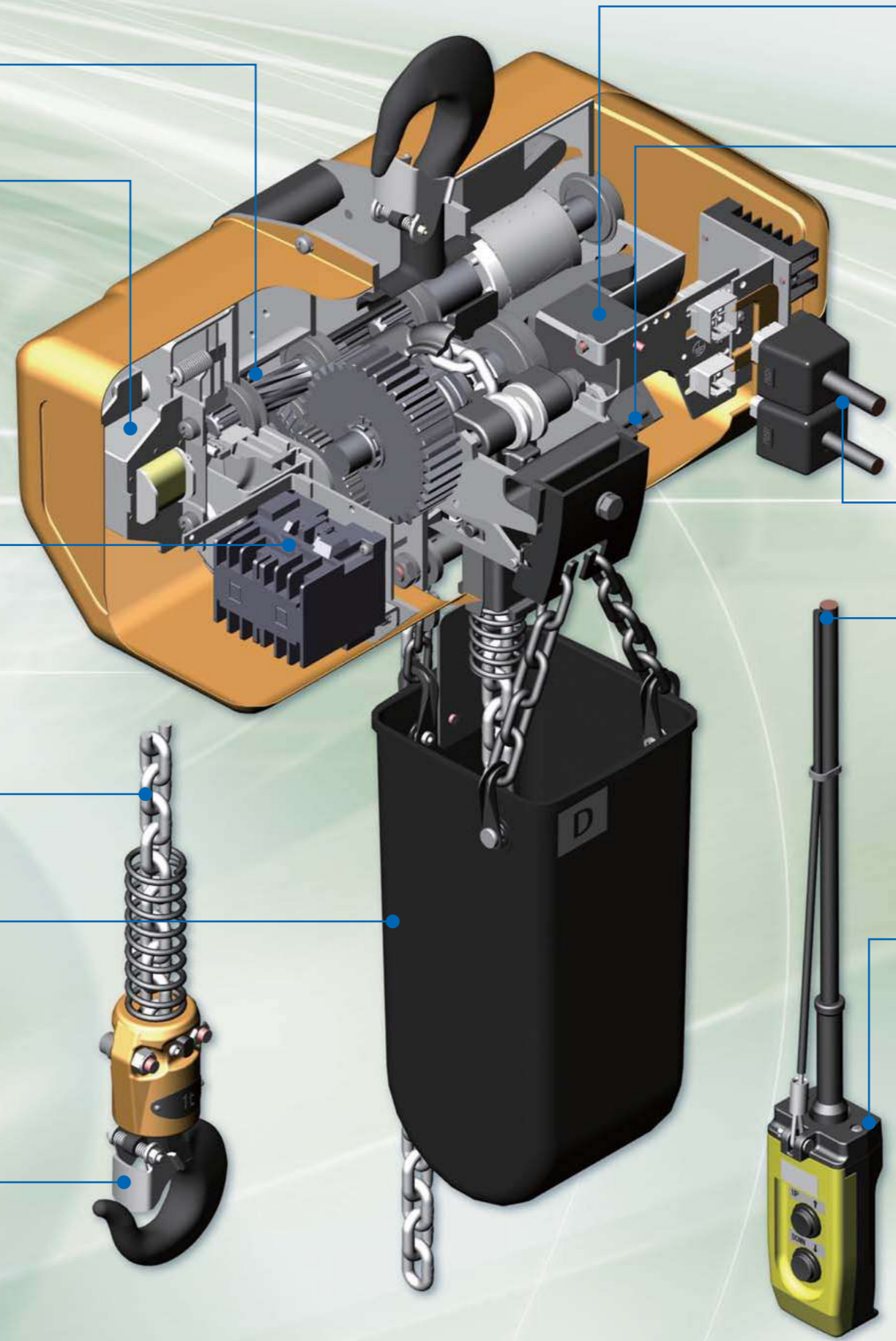

REVERSE PHASE INSPECTION RELAY **S F**

cut control circuit when reverse phasing. Except the 3 phase models of 250 kg and 500 kg, and single phase models.

LIMIT SWITCH (Upper and Lower) **S F**

interrupt motor power to prevent hook overtravel and hazardous condition such as chain kink.

AUXILIARY BRAKE SYSTEM **F**

F series hoists equipped with auxiliary brake.



PLUG-IN CABLES **S F**

reduce maintenance time and installation.

PUSHBUTTON CABLE **S F**

is molded with strain relief wire rope into one body. This assures easier and safer operation.

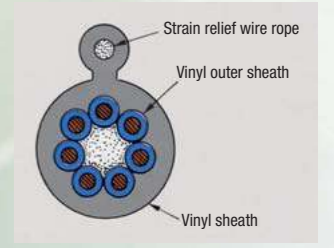

PUSHBUTTON SWITCH **S F**

is rain-proof plastic for severe impact and corrosive atmosphere resistance and mechanically interlocked. The 24 volt control circuit reduce shock hazard to the operation.

HITACHI OVERLOAD LIMITER **S** option **F** option

Unique, patented over load protection device is available on all models upon request.
U.S. PAT. 4103873
CANADA PAT. 1062232
Others

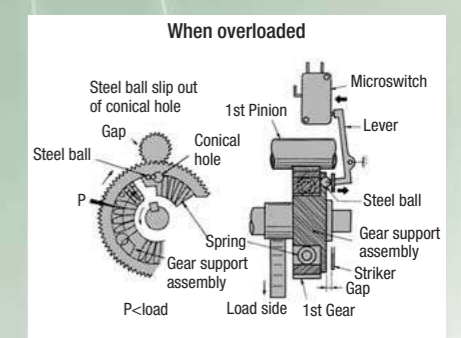

Outline

S series

F series

Others

Conform with Essential Requirements Set Out in European Directives



CE MARKING MODEL S series **S** / F series **F**

HELICAL GEARING **S F**

used where practical to provide quiet operation.

LONG LIFE BRAKE UNIT **S F**

Disk type Electro-Magnetic brake system for steady operation and long life.

AUTOMATIC ADJUSTING BRAKE **F**

are equipped with patented Automatic Adjusting Brake for easier maintenance and added safety.

U.S. PAT. 3908802
Germany PAT. 2354044



ELECTRO-MAGNETIC CONTACTOR **S F**

with mechanical-interlocking against line short by mechanical shock.

POWER CHAIN **S F**

special (patented) alloy steel chain surface hardened for optimum strength and wear resistance. (DIN-5684-8)

CHAIN CONTAINER **S F**

as standard part for safer operation.

LOWER HOOK **S F**

is heat-treated and equipped with safety latch and 360° swivelling.

TRANSFORMER

Fuse is built in a primary side to prevent overheat.

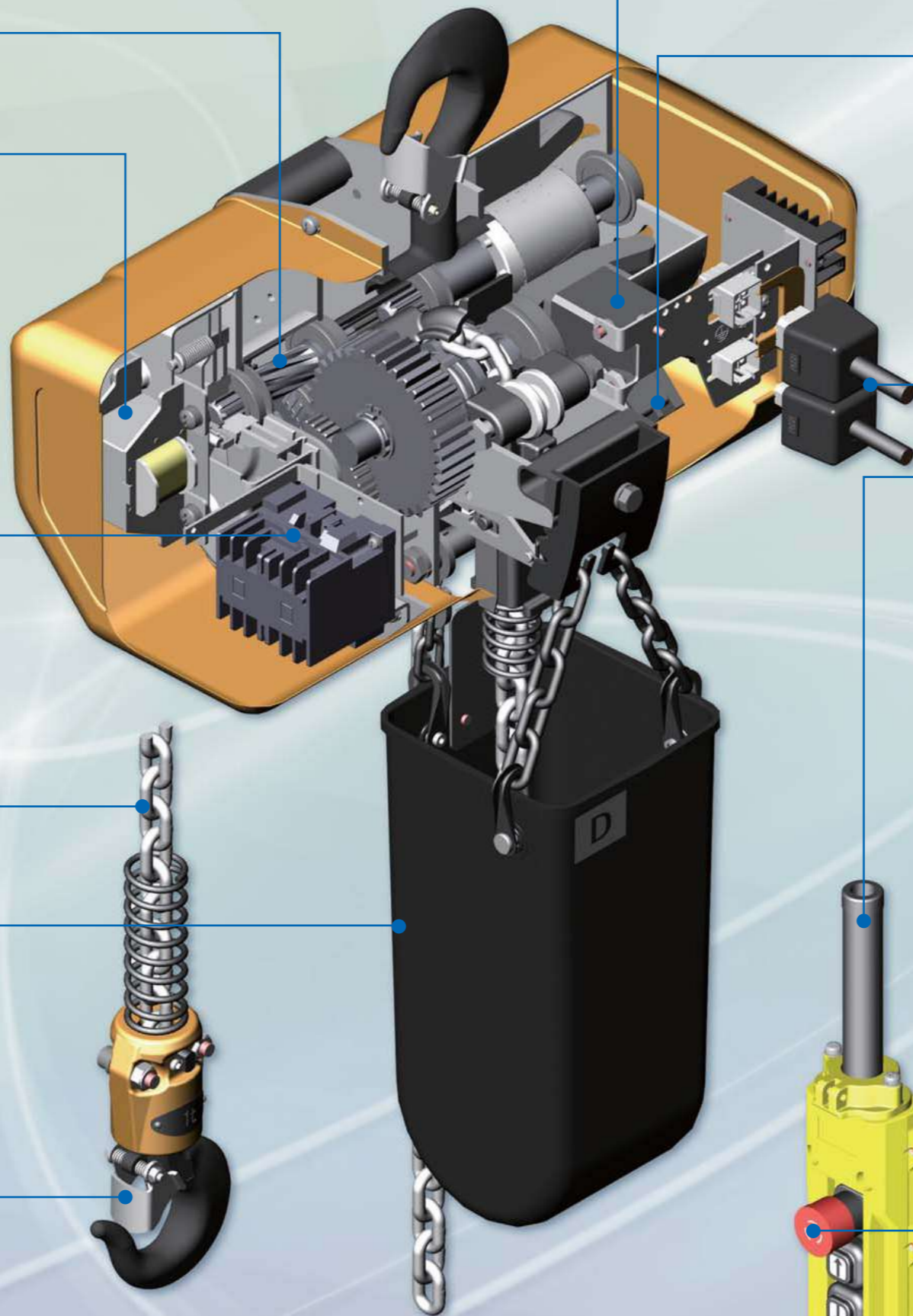
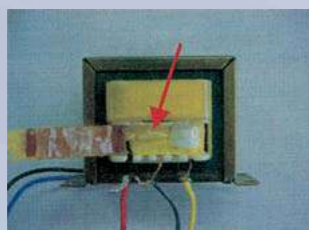

REVERSE PHASE INSPECTING RELAY **S F**

cut control circuit when reverse phasing. Except the 3 phase models of 250 kg and 500 kg, and single phase models.

LIMIT SWITCH (Upper and Lower) **S F**

interrupt motor power to prevent hook overtravel and hazardous condition such as chain kink.

AUXILIARY BRAKE SYSTEM **F**

F series hoists equipped with auxiliary brake.



PLUG-IN CABLES **S F**

reduce maintenance time and installation.

PUSHBUTTON CABLE **S F**

is molded with strain relief wire rope into one body. This assures easier and safer operation.

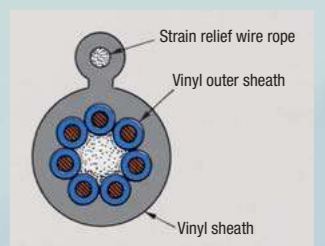

PUSHBUTTON SWITCH **S F**

is rain-proof plastic for severe impact and corrosive atmosphere resistance and mechanically interlocked. The 24 volt control circuit reduce shock hazard to the operation.

● EMERGENCY STOP BUTTON

The chain hoist can be stopped in emergency cases that are caused by overdrive or erroneous operation.



HITACHI OVERLOAD LIMITER **S F**

Unique, patented over load protection device is available on all models upon request. U.S. PAT. 4103873 CANADA PAT. 1062232 Others

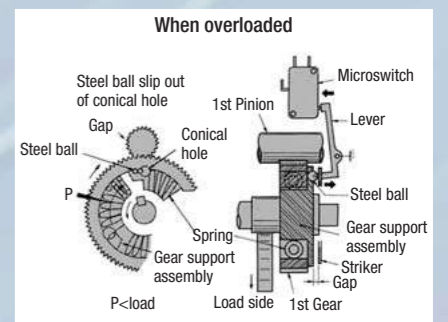

S series

Electric chain hoist

Suspension type

Single speed model

Dual speed model

Single phase model



Specifications table

SINGLE SPEED (3 PHASE)

S(H)

Rated Load (kg)		250	500	1,000	2,000	3,000	5,000
Model Name		1/4S(H) ₂	1/2S(H) ₂	1S(H)	2S(H)	3S(H)	5S(H)
Standard Lift (m)		3(6)					
Hoisting Speed (m/min)	50Hz	10	7.2	4.6	2.3	1.5	0.9
	60Hz	12	8.5	5.5	2.8	1.8	1.1
Motor Output (kW)	50Hz	0.45	0.63	0.8	0.8	0.8	0.8
	60Hz	0.55	0.75	1.0	1.0	1.0	1.0
Link Chain	Dia. (mm)	φ6.3	φ6.3	φ7.1	φ7.1	φ7.1	φ7.1
	No. of	1	1	1	2	3	5
Rating		30% ED			25% ED		
Power Cord Length		5m					

DUAL SPEED (3 PHASE)

SN(H)

Rated Load (kg)		250	500	1,000	2,000
Model Name		1/4SN(H) ₂	1/2SN(H) ₂	1SN(H)	2SN(H)
Standard Lift (m)		3(6)			
Hoisting Speed (m/min)	50Hz	7.2/1.8	7.2/1.8	4.6/1.2	2.3/0.6
	60Hz	8.5/2.1	8.5/2.1	5.5/1.4	2.8/0.7
Motor Output (kW)	50Hz	0.32/0.08	0.63/0.16	0.8/0.2	0.8/0.2
	60Hz	0.38/0.1	0.75/0.19	0.1/0.25	0.1/0.25
Link Chain	Dia. (mm)	φ6.3	φ6.3	φ7.1	φ7.1
	No. of Falls	1	1	1	2
Rating		25% ED		20/10% ED	
Power Cord Length		5m			

SINGLE PHASE

SS(H)₂, S(H)1

Rated Load (kg)		250	500	1,000	2,000	3,000	5,000
Model Name		1/4SS(H) ₂	1/2SS(H) ₂	1S(H)1	2S(H)1	3S(H)1	5S(H)1
Standard Lift (m)		3(6)					
Hoisting Speed (m/min)	50Hz	5.0	3.6	2.3	1.1	0.8	0.45
	60Hz	6.0	4.3	2.8	1.4	0.9	0.55
Motor Output (kW)	50Hz	0.25	0.32	0.4	0.4	0.4	0.4
	60Hz	0.30	0.37	0.5	0.5	0.5	0.5
Link Chain	Dia. (mm)	φ6.3	φ6.3	φ7.1	φ7.1	φ7.1	φ7.1
	No. of Falls	1	1	1	2	3	5
Rating		25% ED			20% ED		
Power Cord Length		5m					

All dimensions and specifications are subject to change without notice.

Suspension type

■ Dimensions

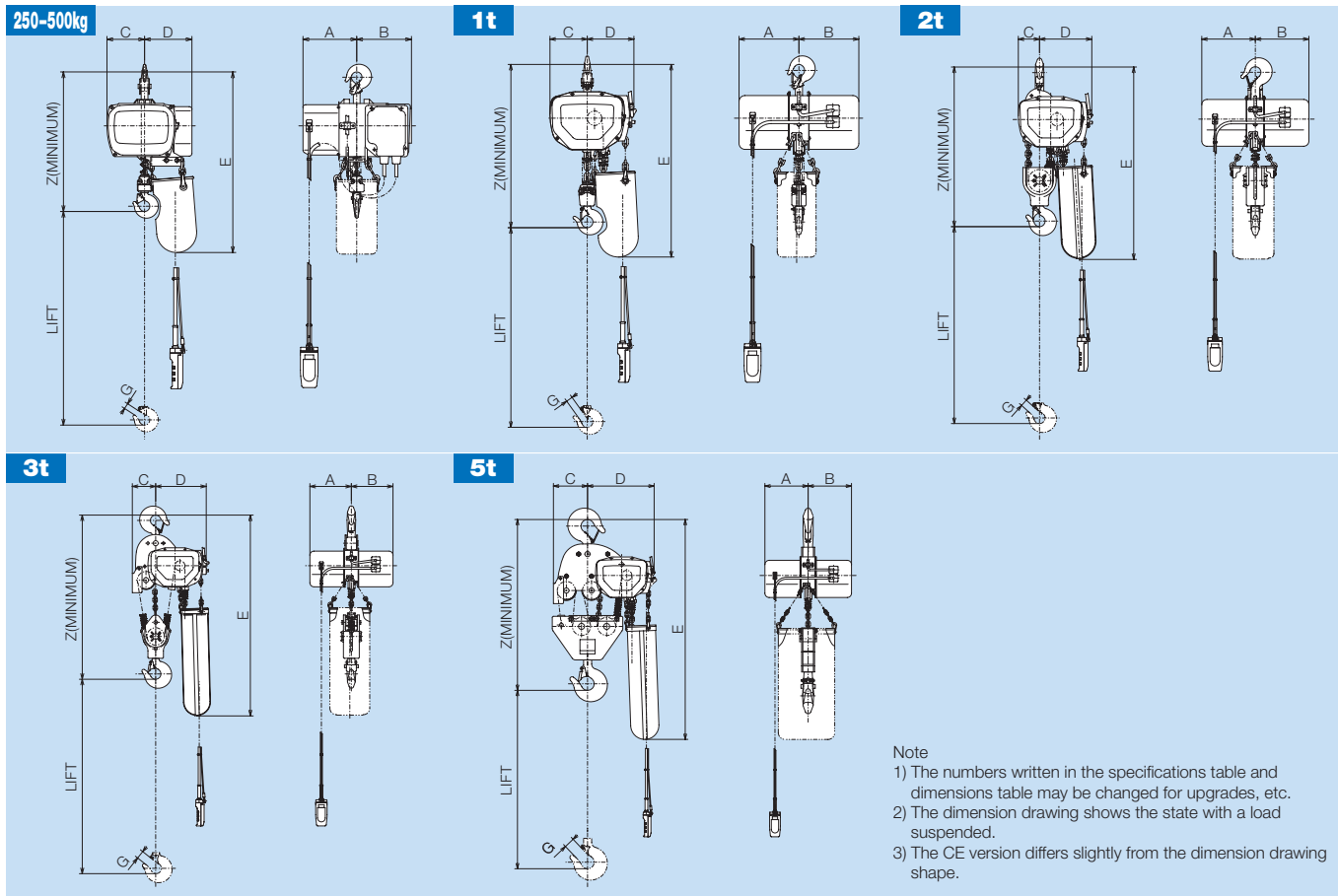

■ Specifications table

SINGLE SPEED (3 PHASE)

Model Name		1/4S ₂	1/4SH ₂	1/2S ₂	1/2SH ₂	1S	1SH	2S	2SH	3S	3SH	5S	5SH
Rated Load	(kg)	250		500		1,000		2,000		3,000		5,000	
Dimensions	Z	450		450		530		645		800		895	
	A	181		181		216		216		216		216	
	B	184		184		216		216		216		216	
	C	125		125		135		90		125		175	
	D	165		165		170		215		270		340	
	D'(CE)	200		200		170		215		270		340	
	E	620		620		680		705	775	835	1,050	1,065	1,095
G	19		19		23		26		42		48		
Approx. Weight	(kg)	28	31	31	34	37	42	49	59	61	72	88	105

All dimensions and specifications are subject to change without notice.

DUAL SPEED (3 PHASE)

Model Name	1/4SN ₂	1/4SNH ₂	1/2SN ₂	1/2SNH ₂	1SN	1SNH	2SN	2SNH	
Rated Load	(kg)	250		500		1,000		2,000	
Dimensions	Z	450		450		530		645	
	A	183		183		216		216	
	B	210		210		246		246	
	C	125		125		135		90	
	D	185		185		170		215	
	D'(CE)	200		200		170		215	
	E	620		620		680		705	775
G	19		19		23		26		
Approx. Weight	(kg)	33	36	36	39	42	47	54	64

SINGLE PHASE

Model Name	1/4SS ₂	1/4SSH ₂	1/2SS ₂	1/2SSH ₂	1S1	1SH1	2S1	2SH1	3S1	3SH1	5S1	5SH1	
Rated Load	(kg)	250		500		1,000		2,000		3,000		5,000	
Dimensions	Z	450		450		530		645		800		895	
	A	181		181		246		246		246		246	
	B	210		210		246		246		246		246	
	C	125		125		135		90		125		175	
	D	165		165		170		215		270		340	
	D'(CE)	200		200		170		215		270		340	
	E	620		620		680		705	775	835	1,050	1,065	1,095
G	19		19		23		26		42		48		
Approx. Weight	(kg)	34	37	34	37	39	44	51	61	63	74	90	107

All dimensions and specifications are subject to change without notice.

With motorized trolley-ET

This can be combined with a 4-point or 6-point pushbutton and used as a motorized trolley or overhead traveling crane.

Dimensions

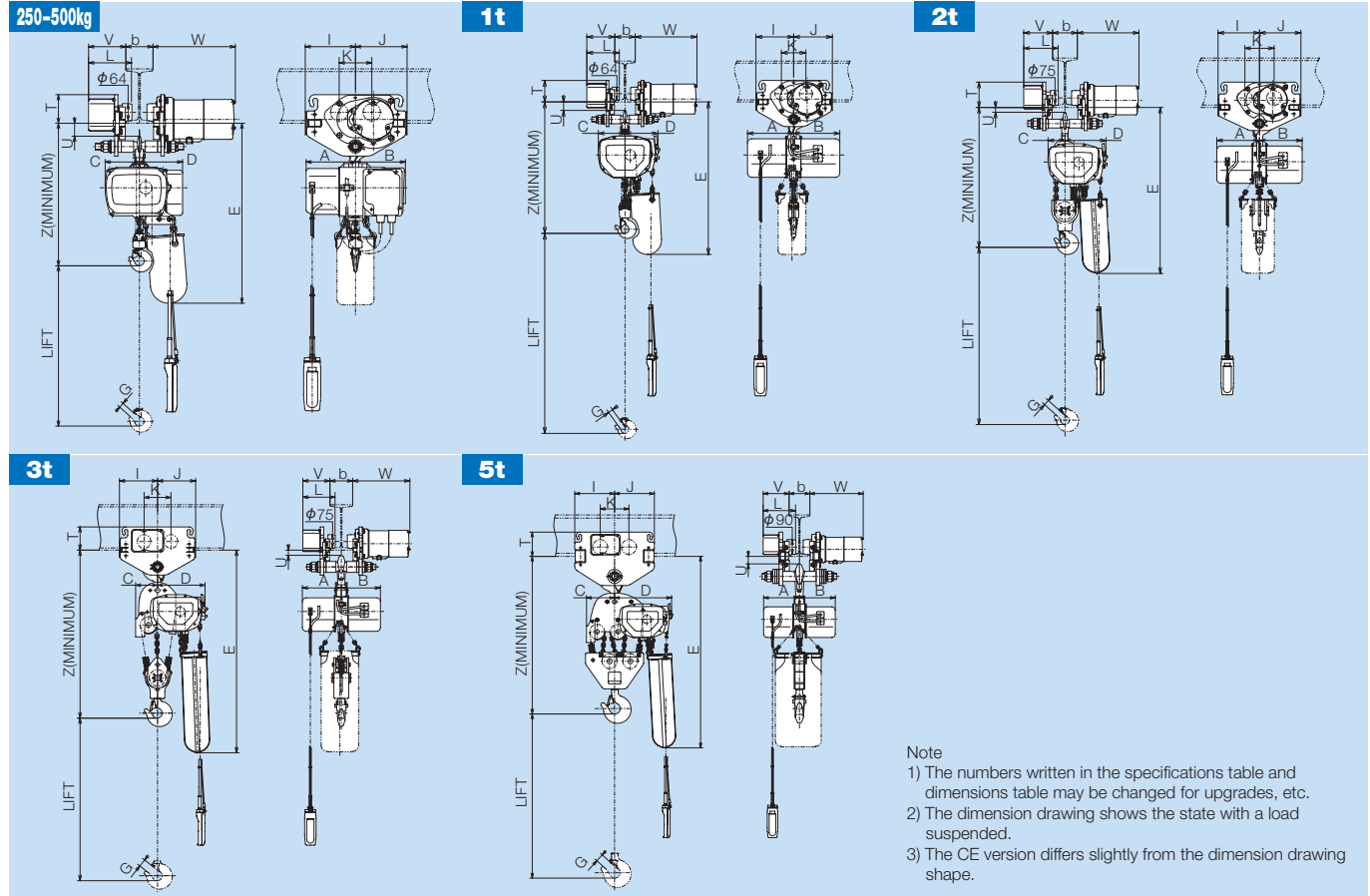

Note
 1) The numbers written in the specifications table and dimensions table may be changed for upgrades, etc.
 2) The dimension drawing shows the state with a load suspended.
 3) The CE version differs slightly from the dimension drawing shape.

Specifications table

Chain Hoist Model Name		1/4S(H) ₂	1/4SN(H) ₂	1/2S(H) ₂	1/2SN(H) ₂	1S(H)	1SN(H)	2S(H)	2SN(H)	3S(H)	5S(H)	
Trolley Type		1ET						2ET		3ET	5ET	
Rated Load (kg)		250		500		1,000		2,000		3,000	5,000	
Dimensions (mm)	Z	523	523	523	523	600	600	700	700	865	984	
	A	181	183	181	183	216	216	216	216	216	216	
	B	184	210	184	210	216	246	216	246	216	216	
	C	125	125	125	125	135	135	90	90	125	175	
	D	165	185	165	185	170	170	215	215	270	340	
	D'(CE)	200	200	200	200	170	170	215	215	270	340	
	E	693	693	693	693	750	750	770(840)		910(1,125)	1,170(1,200)	
	G	19	19	19	19	23	23	26	26	42	48	
	I				185					210	210	240
	J				190					210	210	240
	K				120					148	148	173
	L				182					200	203	219
	T				110					140	140	156
U				38					18	16	34	
V				159					172	175	181	
W				303					313	316	323	
Min. Curve Radius (m)					1.5					1.8	2.0	3.0
Applicable Beam Width b (mm)					75-125					100-150		125-175
Approx. Weight (kg)		66(69)	71(74)	69(72)	74(77)	75(80)	80(85)	101(111)	106(116)	121(132)	174(191)	

All dimensions and specifications are subject to change without notice.

Motorized trolley specifications table

Series Name		ET series				ST series		
Model Name		1ET	2ET	3ET	5ET	1ST	2ST	3ST
Working Load Limit (kg)		1,000	2,000	3,000	5,000	1,000	2,000	3,000
Traveling Speed (m/min)	50Hz	10.5(21)				10.5		
	60Hz	12.5(25)				12.5		
Motor Output (kW)	50Hz	0.14(0.27)		0.3(0.6)		0.07	0.14	0.2
	60Hz	0.16(0.32)		0.35(0.7)		0.08	0.16	0.24
Applicable Beam Width b (mm)		75-125	100-150		125-175	75-125	100-150	
Rating		25%ED				25%ED		

With motorized trolley-ST

This can be combined with a 4-point or 6-point pushbutton and used as a motorized trolley or overhead traveling crane.

Dimensions

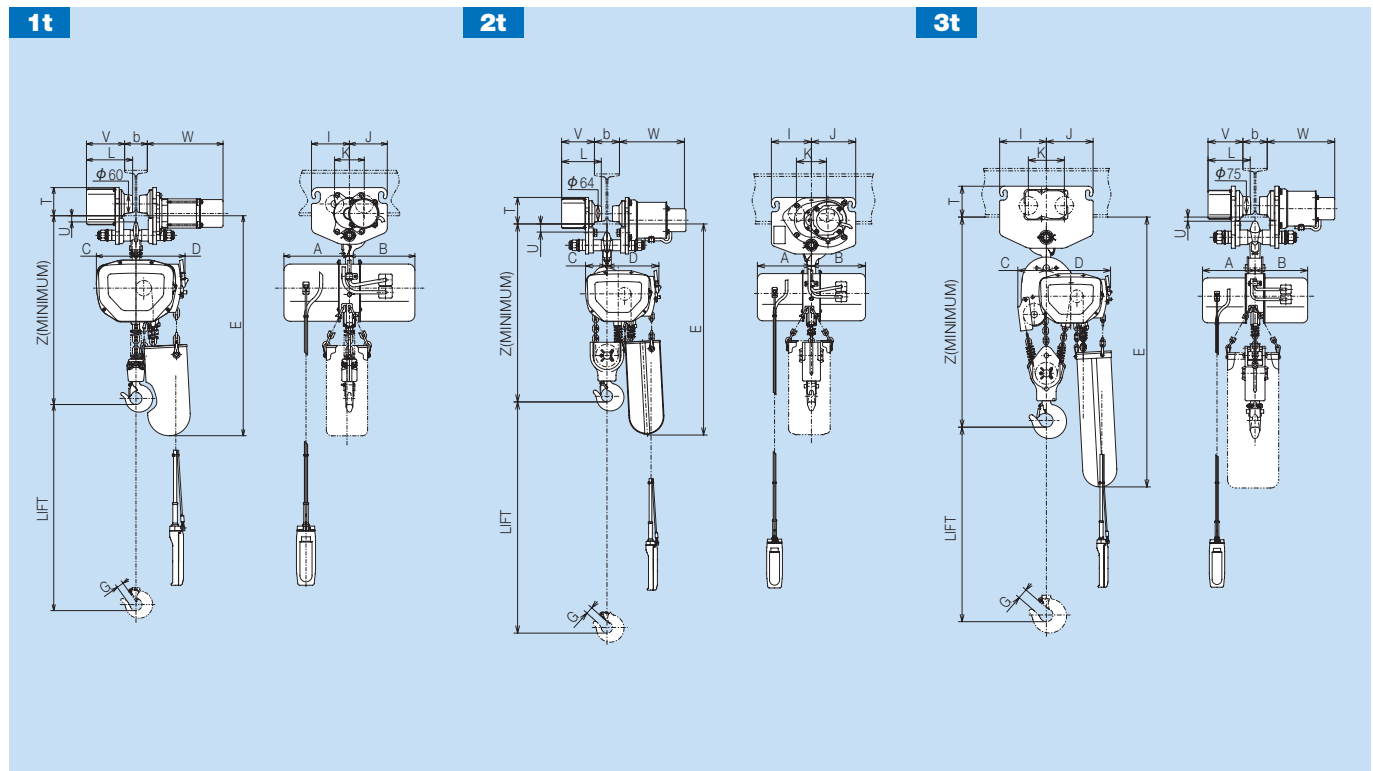

Specifications table

Chain Hoist Model Name	1S(H)	1SN(H)	2S(H)	2SN(H)	3S(H)
Trolley Type	1ST		2ST		3ST
Rated Load (kg)	1,000		2,000		3,000
Z	578	578	700	700	852
A	216	216	216	216	216
B	216	246	216	246	216
C	135	135	90	90	125
D, D'(CE)	170	170	215	215	270
E	730	730	772(842)		900(1,115)
G	23	23	26	26	42
I	125		160		192
J	125		177		192
K	98		120		148
L	156		163		180
T	101		119		140
U	18		19		5
V	130		135		145
W	255		270		280
Min. Curve Radius (m)	1.8		2.5		3.0
Applicable Beam Width b (mm)	75-100		100-150		100-150
Approx. Weight (kg)	60(65)	65(70)	86(96)	91(101)	109(120)

All dimensions and specifications are subject to change without notice.

With chain driven trolley-BC

The electric chain hoist with chain driven trolley is suitable for relatively heavy loads not transported a long distance.

Dimensions

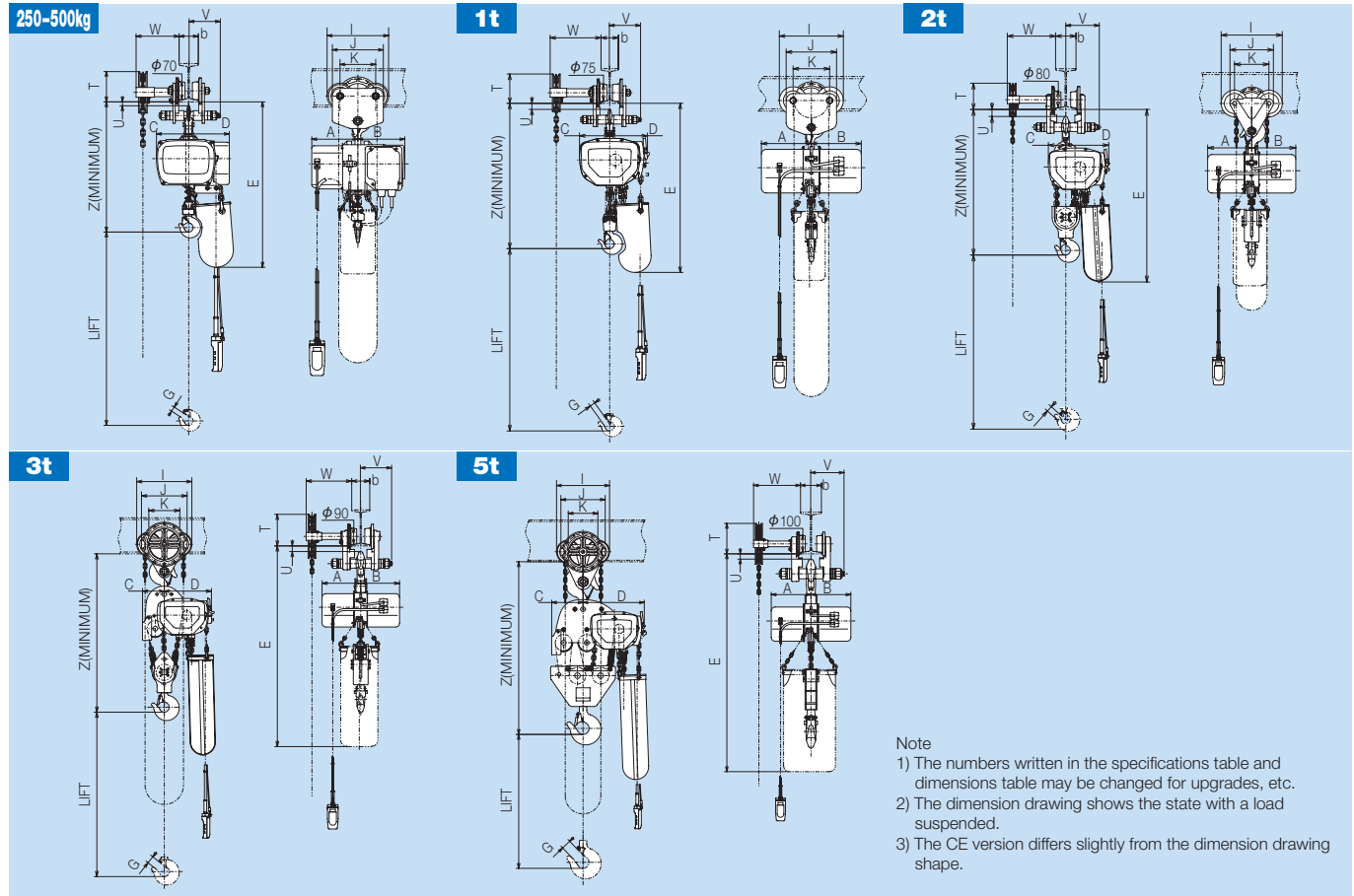

Specifications table

Chain Hoist Model Name	1/4S(H) ₂	1/4SN(H) ₂	1/2S(H) ₂	1/2SN(H) ₂	1S(H)	1SN(H)	2S(H)	2SN(H)	3SH	5SH	
Trolley type	1/2BC(H)				1BC(H)		2BC(H)		3BCH	5BCH	
Rated Load (kg)	250		500		1,000		2,000		3,000	5,000	
Dimensions (mm)	Z	513	513	513	513	585	585	703	703	866	980
	A	181	183	181	183	216	216	216	216	216	216
	B	184	210	184	210	216	246	216	246	216	216
	C	125	125	125	125	135	135	90	90	125	175
	D	165	185	165	185	170	170	215	215	270	340
	D'(CE)	200	200	200	200	170	170	215	215	270	340
	E	685	685	685	685	740	740	775(845)		1,130	1,190
	G	19	19	19	19	23	23	26	26	42	48
	I	242				277		300		306	319
	J	199				218		213		240	262
	K	139				158		169		172	177.2
	T	129				131		143		191	194
	U	13				23		22		21	30
V	124				135		165		173	200	
W	188				220		236		252	284	
Min. Curve Radius (m)	1.0				1.2		1.5		1.5	2.4	
Applicable Beam Width b (mm)	75-125				75-125		100-150		100-150	125-175	
Approx. Weight (kg)	44(50)	49(55)	47(53)	52(58)	58(66)	63(71)	73(86)	78(91)	116	161	

With manual driven trolley-BP

The electric chain hoist with manual driven trolley is suitable for relatively light loads transported a short distance.

Dimensions

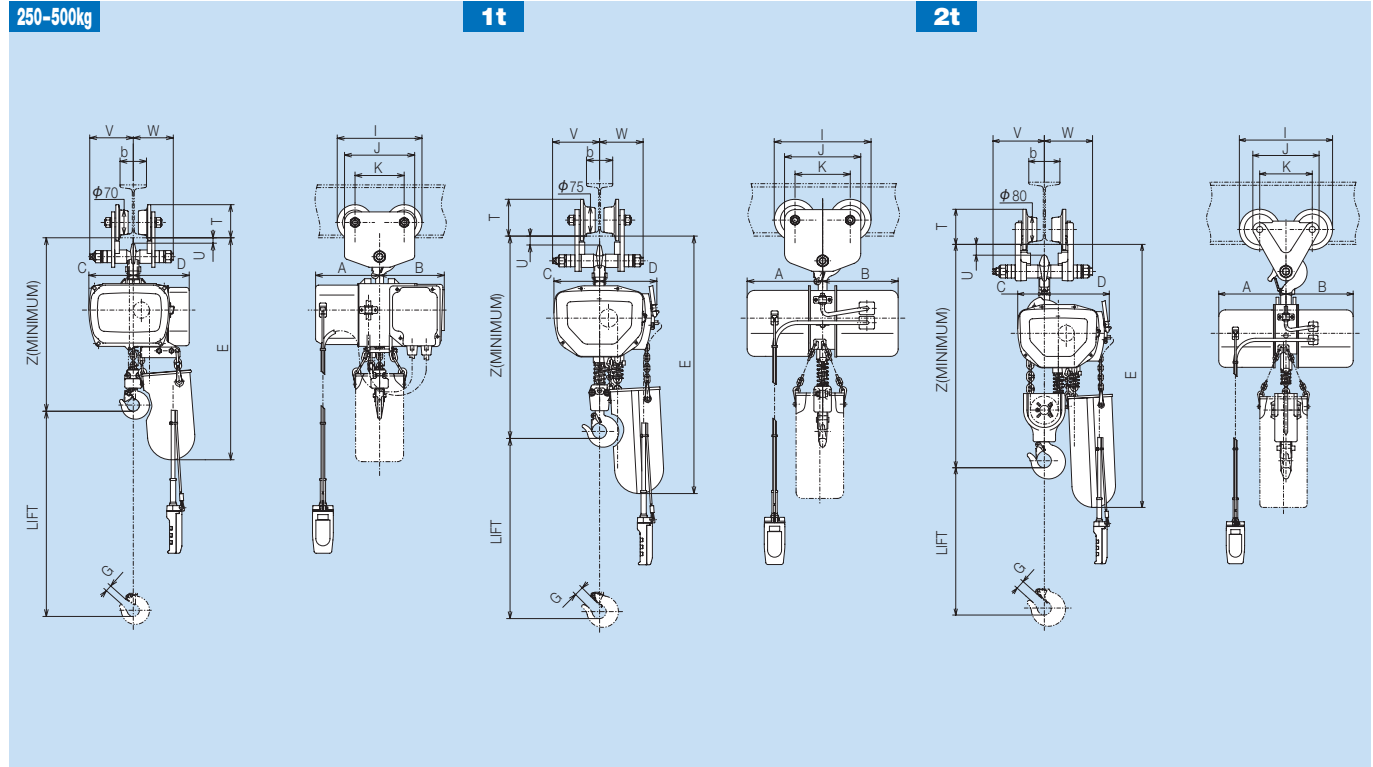

Specifications table

Chain Hoist Model Name		1/4S(H) ₂	1/4SN(H) ₂	1/2S(H) ₂	1/2SN(H) ₂	1S(H)	1SN(H)	2S(H)	2SN(H)
Trolley type		1/2BP				1BP		2BP	
Rated Load (kg)		250		500		1,000		2,000	
Dimensions (mm)	Z	513	513	513	513	585	585	703	703
	A	181	183	181	183	216	216	216	216
	B	184	210	184	210	216	246	216	246
	C	125	125	125	125	135	135	90	90
	D	165	185	165	185	170	170	215	215
	D'(CE)	200	200	200	200	170	170	215	215
	E	685	685	685	685	740	740	775(845)	
	G	19	19	19	19	23	23	26	26
	I	242				277		300	
	J	199				199		213	
	K	139				139		169	
	T	98				110		128	
	U	13				23		22	
	V	124				135		165	
W	114				125		155		
Min. Curve Radius (m)	1.0					1.2		1.5	
Applicable Beam Width b (mm)	75-125					75-125		100-150	
Approx. Weight (kg)	38(41)	43(46)	41(44)	46(49)	52(57)	57(62)	66(76)	71(81)	

Chain driven trolley, manual driven trolley specifications table

Classification		Chain driven trolley					Manual driven trolley		
Model Name		1/2BC(H)	1BC(H)	2BC(H)	3BCH	5BCH	1/2BP	1BP	2BP
Working Load Limit (kg)		500	1,000	2,000	3,000	5,000	500	1,000	2,000
Standard Lift (m)		3(6)	3(6)	3(6)	6	6	—	—	—
Min. Curve Radius (m)		1.0	1.2	1.5	1.5	2.4	1.0	1.2	1.5
Applicable Beam Width b (mm)		75-125		100-150		125-175	75-125		100-150

For a crane that uses a chain or manual driven trolley for transverse movement and an electric motor for travel, please purchase a 4PB(H)-C, 4PBN(H)-C type wiring unit (See page 23).

F series

Electric chain hoist

Suspension type

Single speed model

Dual speed model



Specifications table

SINGLE SPEED (3 PHASE)

F(H)

Rated Load (kg)		1,000	2,000	3,000	5,000	10,000	15,000	20,000
Model Name		1F(H)	2F(H)	3F(H)	5F(H)	10FH	15FH	20FH
Standard Lift (m)		3(6)				6		
Hoisting Speed (m/min)	50Hz	7.1	6.8	4.1	2.8	2.8	1.8	1.4
	60Hz	8.5	8.2	4.9	3.3	3.3	2.2	1.6
Motor Output (kW)	50Hz	1.3		2.4		2.4×2		
	60Hz	1.6		2.9		2.9×2		
Link Chain	Dia. (mm)	φ 7.1			φ 10			
	No. of Falls	1	1	2	3	4	6	8
Rating		30% ED						
Power Cord Length		5m						

DUAL SPEED (3 PHASE)

FN(H)

Rated Load (kg)		2,000	3,000	5,000	10,000	15,000
Model Name		2FN(H)	3FN(H)	5FN(H)	10FNH	15FNH
Standard Lift (m)		3(6)			6	6
Hoisting Speed (m/min)	50Hz	6.8/1.7	4.0/1.0	2.8/0.7	2.8/0.7	1.8/0.45
	60Hz	8.2/2.0	4.8/1.2	3.3/0.8	3.3/0.8	2.2/0.55
Motor Output (kW)	50Hz	2.4/0.6		2.4/0.6×2		
	60Hz	2.9/0.7		2.9/0.7×2		
Link Chain	Dia. (mm)	φ 10				
	No. of Falls	1	2	3	4	6
Rating		20% ED				
Power Cord Length		5m				

All dimensions and specifications are subject to change without notice.

Suspension type

Dimensions

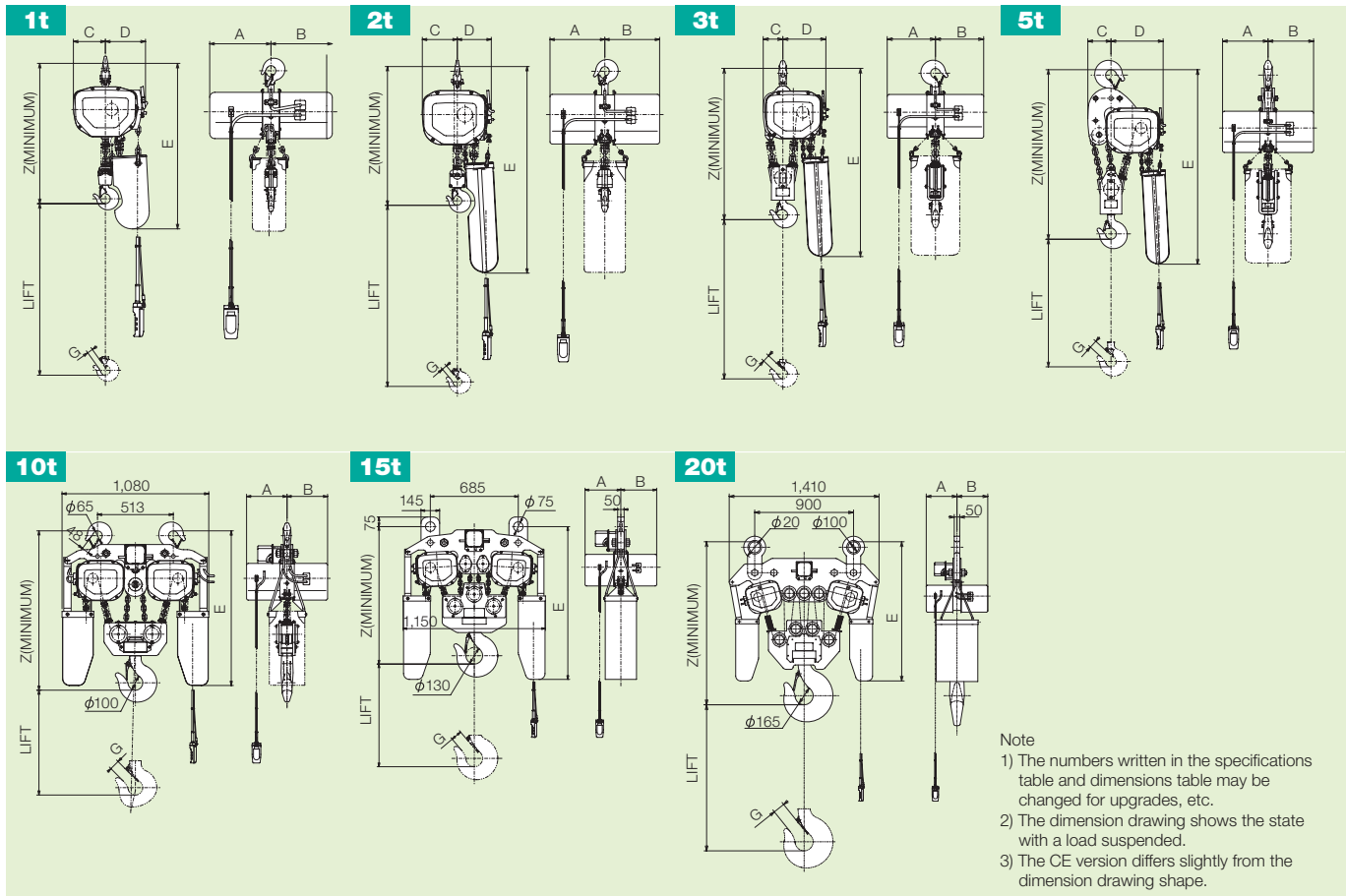

Specifications table

SINGLE SPEED (3 PHASE)

Model Name		1F	1FH	2F	2FH	3F	3FH	5F	5FH	10FH	15FH	20FH
Rated Load	(kg)	1,000		2,000		3,000		5,000		10,000	15,000	20,000
Dimensions	Z	535		660		820		1,020		1,060	1,235	1,440
	A	250		280		280		280		280	280	280
	B	250		280		280		280		280	280	280
	C	135		175		120		145		—	—	—
	D	170		170		245		330		—	—	—
	E	680		845	1,060	1,090	1,100	1,295	1,305	1,040	1,280	1,400
	G	23		26		42		48		68	86	108
Approx. Weight	(kg)	42	47	80	87	99	113	121	142	330	490	690

All dimensions and specifications are subject to change without notice.

DUAL SPEED (3 PHASE)

Model Name		2FN	2FNH	3FN	3FNH	5FN	5FNH	10FNH	15FNH
Rated Load	(kg)	2,000		3,000		5,000		10,000	15,000
Dimensions	Z	660		820		1,020		1,060	1,235
	A	280		280		280		280	280
	B	330		330		330		330	330
	C	175		120		145		—	—
	D	170		245		330		—	—
	E	845	1,060	1,090	1,100	1,295	1,305	1,040	1,280
	G	26		42		48		68	86
Approx. Weight	(kg)	96	102	112	126	146	167	360	520

All dimensions and specifications are subject to change without notice.

With motorized trolley-ET

This can be combined with a 4-point or 6-point pushbutton and used as a motorized trolley or overhead traveling crane.

■ Dimensions

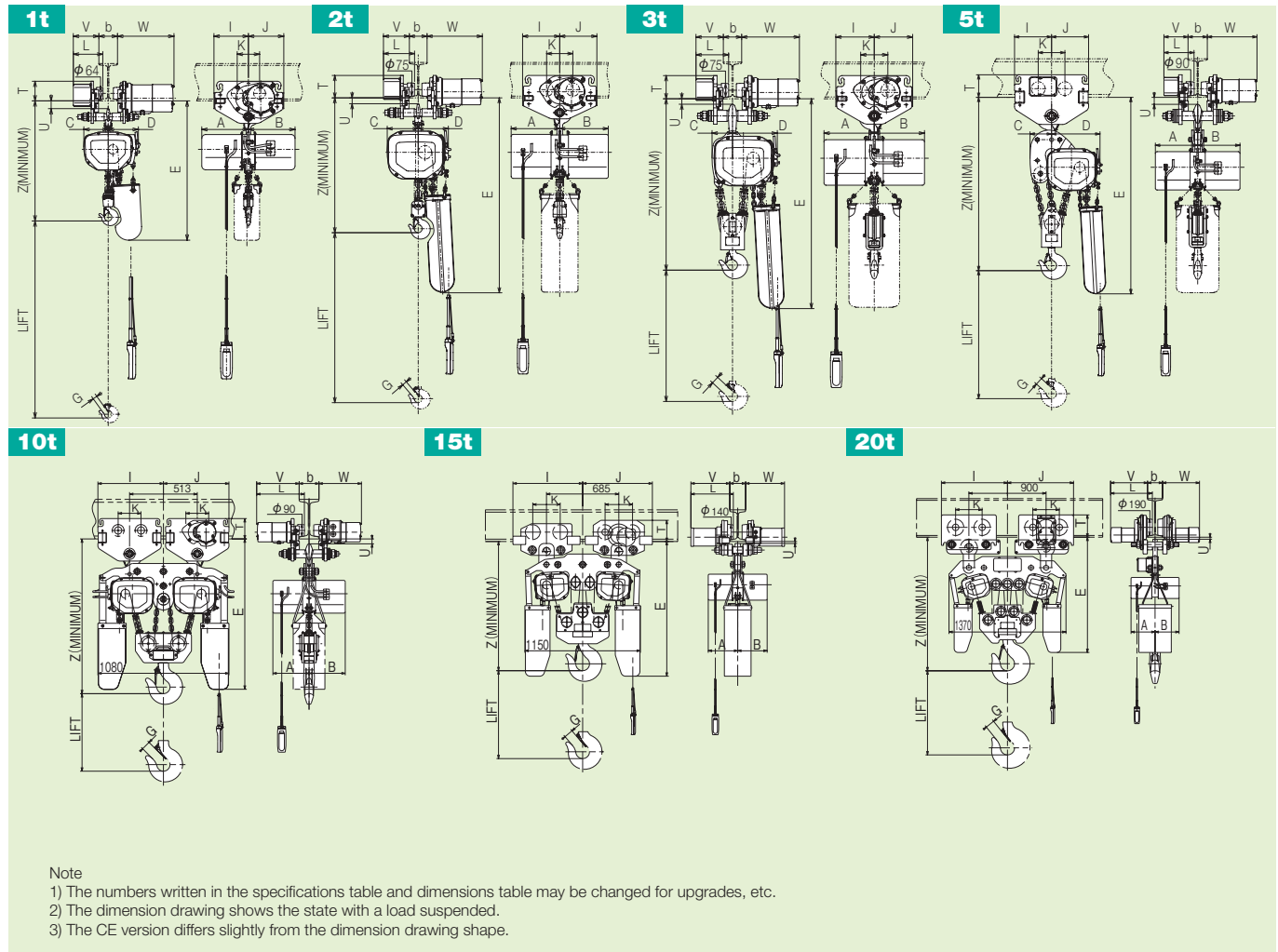

■ Specifications table

Chain Hoist Model Name	1F(H)	2F(H)	2FN(H)	3F(H)	3FN(H)	5F(H)	5FN(H)	10FH	10FNH	15FH	15FNH	20FH						
Trolley Type	1ET	2ET	3ET	5ET	5ET×2	7.5ET×2	10ET×2											
Rated Load (kg)	1,000	2,000	3,000	5,000	10,000	15,000	20,000											
Dimensions (mm)	Z	604	715	715	882	882	1,112	1,112	1,150	1,152	1,150	1,152	1,210	1,212	1,210	1,212	1,520	1,515
	A	250	280	280	280	280	280	280	280	280	280	280	280	280	280	280	280	280
	B	250	280	330	280	330	280	330	280	330	280	330	280	330	280	330	280	330
	C	135	185	185	120	120	145	145	—	—	—	—	—	—	—	—	—	—
	D	170	170	170	245	245	330	330	—	—	—	—	—	—	—	—	—	—
	E	750	945(1,125)	1,130(1,185)	1,410	1,410	1,130	1,130	1,265	1,265	1,265	1,265	1,375	1,375	1,375	1,375	1,375	1,375
	G	23	26	26	42	42	48	48	68	68	86	86	108	108	108	108	108	108
	I	185	210	210	210	240	500	500	663	663	663	663	770	770	770	770	770	770
	J	190	210	210	240	240	500	500	663	663	663	663	770	770	770	770	770	770
	K	120	148	148	173	173	260	260	309	309	309	309	309	309	309	309	309	309
	L	182	200	203	219	219	362	362	434	434	434	434	511	511	511	511	511	511
	T	110	140	140	156	156	158	156	205	203	205	203	280	285	280	285	280	285
	U	38	18	16	34	34	32	34	15	17	15	17	23	18	23	18	23	18
	V	159	172	175	181	181	323	323	401	401	401	401	455	455	455	455	455	455
W	303	313	316	323	323	323	323	401	401	401	401	455	455	455	455	455	455	
Min. Curve Radius (m)	1.5	1.8	2.0	3.0	3.0	5.0	5.0	5.0	5.0	5.0	5.0	Straight	Straight	Straight	Straight	Straight	Straight	
Applicable Beam Width b (mm)	75-125	100-150	100-150	125-175	125-175	150	175	150	175	150	175	175	190	175	190	175	190	
Approx. Weight (kg)	80(85)	132(139)	147(154)	161(175)	176(190)	217(238)	232(253)	502	532	860	890	1,490	1,490	860	890	1,490	1,490	

All dimensions and specifications are subject to change without notice.

With motorized trolley-ST

This can be combined with a 4-point or 6-point pushbutton and used as a motorized trolley or overhead traveling crane.

Dimensions

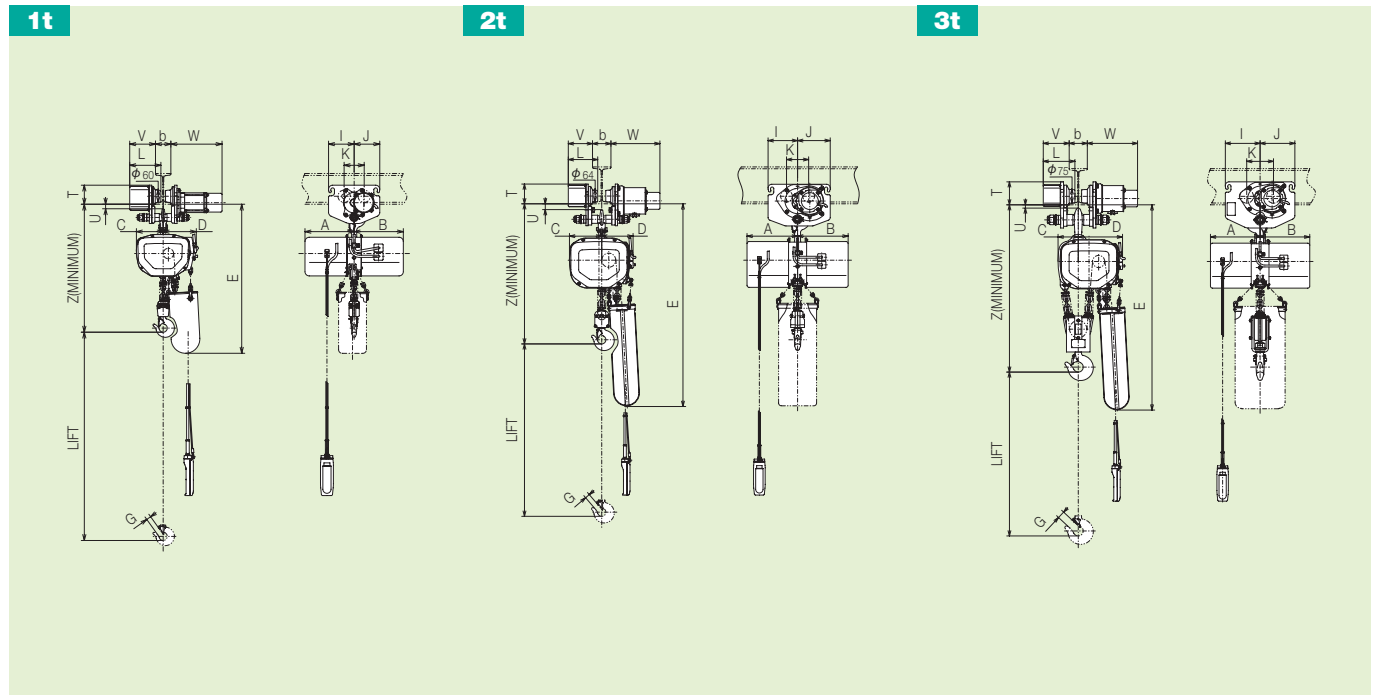

Specifications table

Chain Hoist Model Name		1F(H)	2F(H)	2FN(H)	3F(H)	3FN(H)
Trolley Type		1ST	2ST		3ST	
Rated Load (kg)		1,000	2,000		3,000	
Dimensions (mm)	Z	582	715	715	872	872
	A	250	280	280	280	280
	B	250	280	330	280	330
	C	135	185	185	120	120
	D	170	170	170	245	245
	E	725	935(1,115)		1,110(1,165)	
	G	23	26	26	42	42
	I	125	160		192	
	J	125	177		192	
	K	98	120		148	
	L	156	163		180	
	T	101	119		140	
	U	18	19		5	
	V	130	135		145	
W	255	270		280		
Min. Curve Radius (m)		1.8	2.5		3.0	
Applicable Beam Width b (mm)		75-125	100-150		100-150	
Approx. Weight (kg)		66(71)	117(124)	132(139)	140(161)	155(176)

Motorized trolley specifications table

Series Name		ET series							ST series		
Model Name		1ET	2ET	3ET	5ET	5ET×2	7.5ET×2	10ET×2	1ST	2ST	3ST
Working Load Limit (kg)		1,000	2,000	3,000	5,000	10,000	15,000	20,000	1,000	2,000	3,000
Travelling Speed (m/min)	50Hz	10.5(21)				10.5		14	10.5		
	60Hz	12.5(25)				12.5		17	12.5		
Motor Output (kW)	50Hz	0.14(0.27)		0.3(0.6)		0.3×2	0.35×2	0.7×2	0.07	0.14	0.2
	60Hz	0.16(0.32)		0.35(0.7)		0.35×2	0.42×2	0.84×2	0.08	0.16	0.24
Applicable Beam Width b (mm)		75-125	100-150		125-175	150, 175		175, 190	75-125	100-150	
Rating		25%ED						40%ED	25%ED		

All dimensions and specifications are subject to change without notice.

With chain driven trolley-BC

The electric chain hoist with chain driven trolley is suitable for relatively heavy loads not transported a long distance.

Dimensions

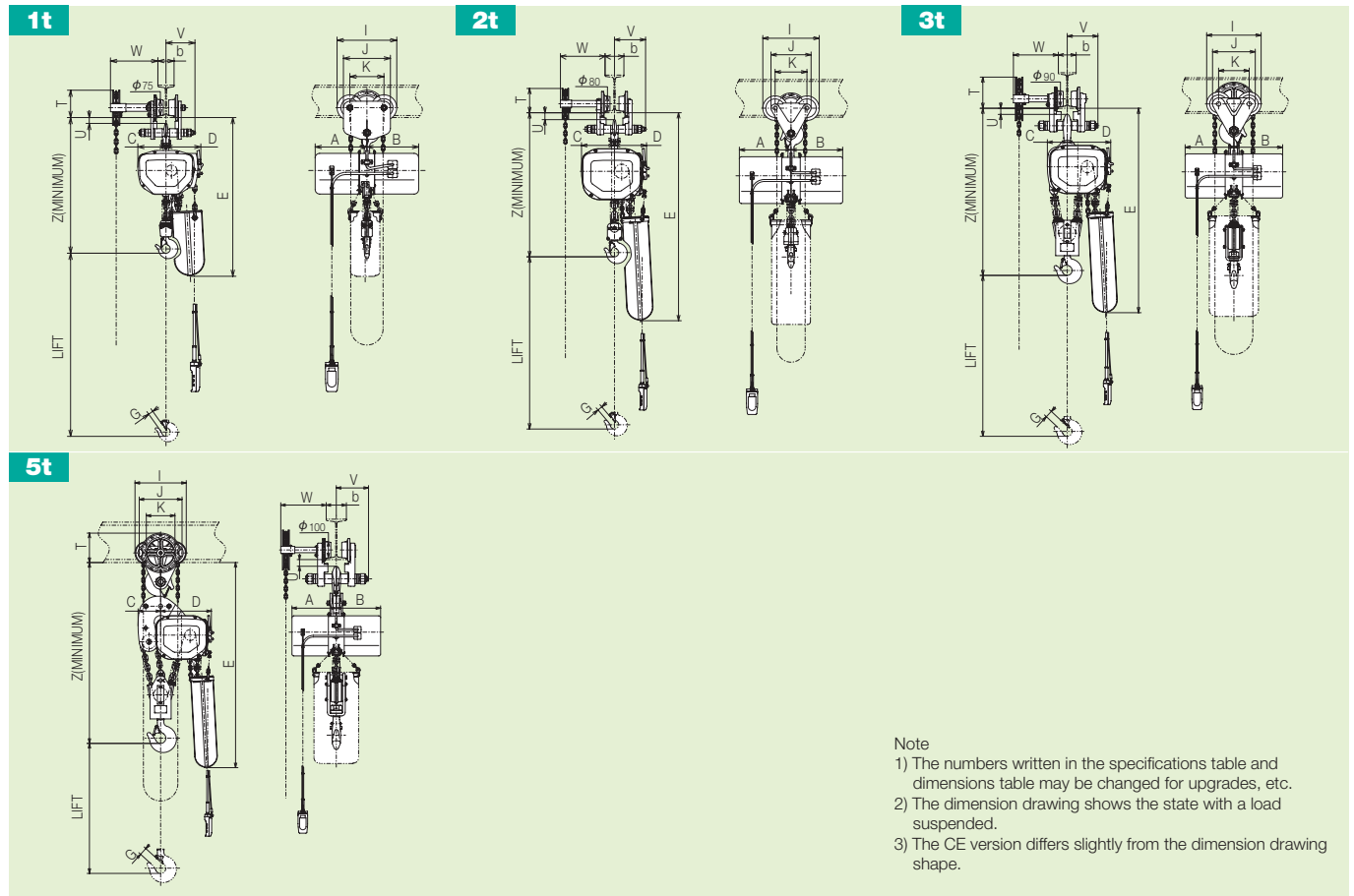

Note

- 1) The numbers written in the specifications table and dimensions table may be changed for upgrades, etc.
- 2) The dimension drawing shows the state with a load suspended.
- 3) The CE version differs slightly from the dimension drawing shape.

Specifications table

Chain Hoist Model Name		1F(H)	2F(H)	2FN(H)	3FH	3FNH	5FH	5FNH
Trolley type		1BC(H)	2BC(H)		3BCH		5BCH	
Rated Load (kg)		1,000	2,000		3,000		5,000	
Dimensions (mm)	Z	600	717	717	886	886	1,105	1,105
	A	250	280	280	280	280	280	280
	B	250	280	330	280	330	280	330
	C	135	175	175	120	120	145	145
	D	170	170	170	245	245	330	330
	E	740	1,130	1,130	1,180	1,180	1,405	1,405
	G	23	26	26	42	42	48	48
	I	277	300		306		319	
	J	218	213		240		262	
	K	158	169		172		177.2	
	L	—	—		—		—	
	T	131	143		191		194	
	U	23	22		21		30	
V	135	165		173		200		
W	220	236		252		284		
Min. Curve Radius	(m)	1.2	1.5		1.5		2.4	
Applicable Beam Width b	(mm)	75–125	100–150		100–150		125–175	
Approx. Weight	(kg)	63(71)	104(114)	120(129)	157	170	198	223

With manual driven trolley-BP

The electric chain hoist with manual driven trolley is suitable for relatively light loads transported a short distance.



Dimensions

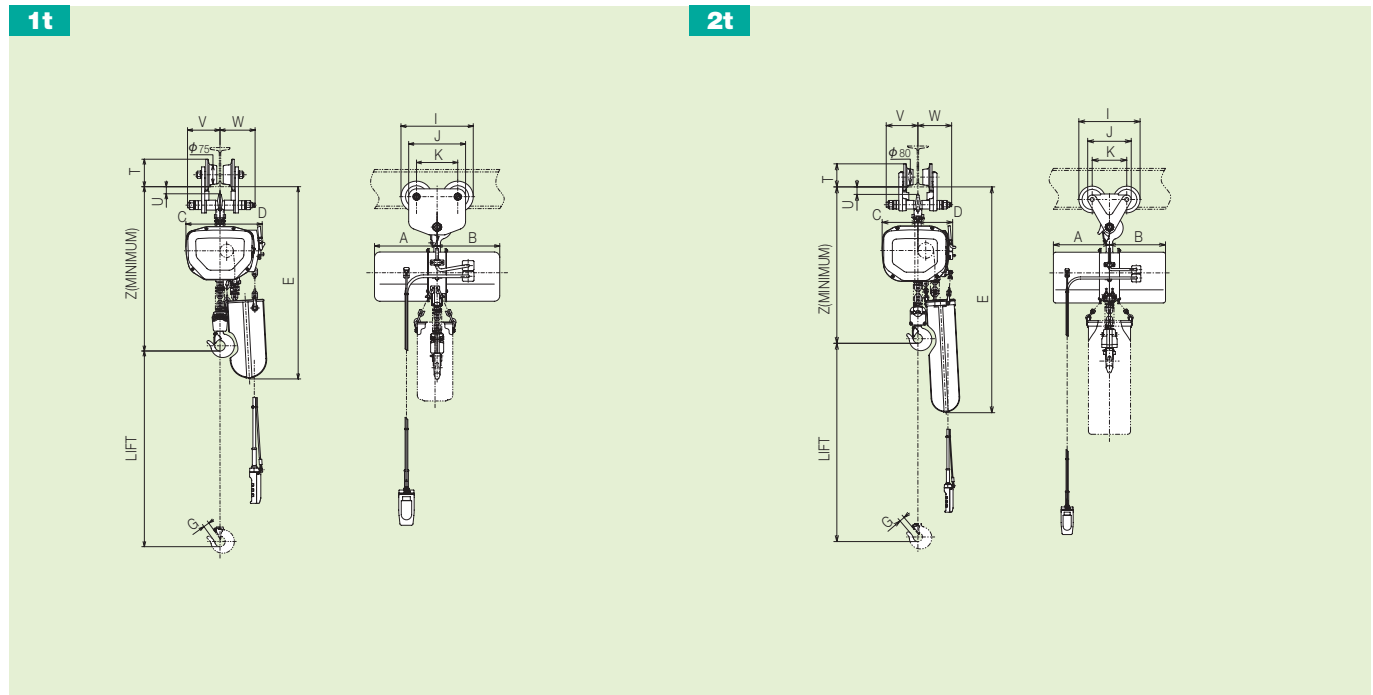

Specifications table

Chain Hoist Model Name		1F(H)	2F(H)	2FN(H)
Trolley type		1BP	2BP	
Rated Load (kg)		1,000	2,000	
Dimensions (mm)	Z	600	717	717
	A	250	280	280
	B	250	280	330
	C	135	175	175
	D	170	170	170
	E	740	1,130	1,130
	G	23	26	26
	I	277	300	
	J	218	213	
	K	158	169	
	L	—	—	
	T	110	128	
	U	23	22	
	V	125	155	
W	135	165		
Min. Curve Radius	(m)	1.2	1.5	
Applicable Beam Width b	(mm)	75–125	100–150	
Approx. Weight	(kg)	57(62)	97(104)	113(119)

Chain driven trolley, manual driven trolley specifications table

Classification	Chain driven trolley				Manual driven trolley	
	1BC(H)	2BC(H)	3BCH	5BCH	1BP	2BP
Model Name	1,000	2,000	3,000	5,000	1,000	2,000
Working Load Limit (kg)	1,000	2,000	3,000	5,000	1,000	2,000
Standard Lift (m)	3(6)	3(6)	6	6	—	—
Min. Curve Radius (m)	1.2	1.5	1.5	2.4	1.2	1.5
Applicable Beam Width b (mm)	75–125	100–150		125–175	75–125	100–150

For a crane that uses a chain or manual driven trolley for transverse movement and an electric motor for travel, please purchase a 4PB(H)-C, 4PBN(H)-C type wiring unit (See page 23).

Outline

S series

F series

Others

Crane wiring unit

4-point pushbutton crane wiring unit

- This is a wiring unit for connecting to the crane electro-magnetic switch and the hoist main unit.
- Connection can be done simply by just attaching to the hoist main unit.
- A unique HITACHI operation cable with a single protective wire provides excellent operability and durability.
- The pushbutton is made of drip-proof hardened plastic.
- The pushbutton cable employs a one-touch outlet to allow it to be connected easily.

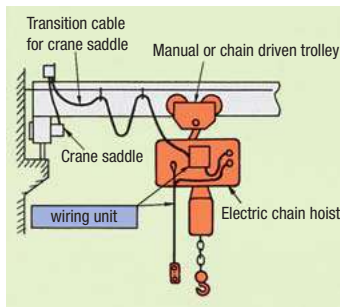

Specifications table

The product is a wiring unit that combines an electric chain hoist with a crane saddle for use with manual traverse (manual or chain driven trolley) and motorized travel 4-point pushbutton cranes.

For single speed models

Model Name	4PB-C	4PBH-C
Lift	3m	6m
Approx. Weight	3kg	3.5kg

For double speed models

Model Name	4PBN-C	4PBNH-C
Lift	3m	6m
Approx. Weight	3.5kg	4kg

Electro-magnetic switch unit with crane case

- This is the electro-magnetic switch unit with a case for girder operation (24V) for when a HITACHI electric chain hoist (with motorized trolley) is used in a crane girder system. (Applicable up to HITACHI crane saddle TLU5-56 and TH5-56)

- Install in a freely selected location of the girder system, and the transition cables for girder and trolley, and the power cable are connected to the terminal block.

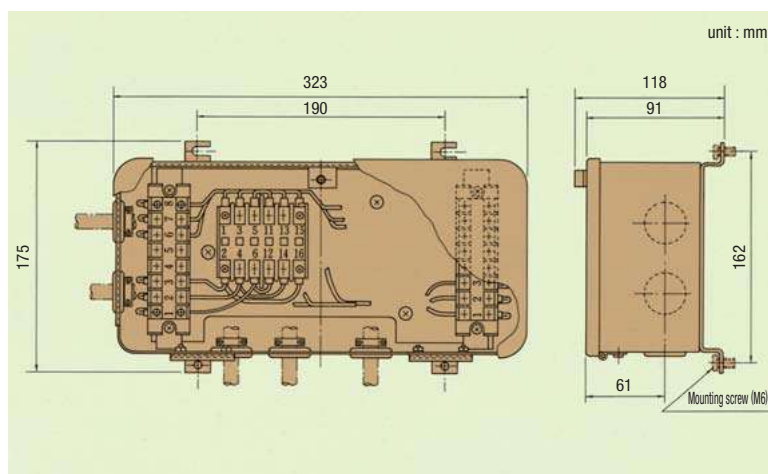
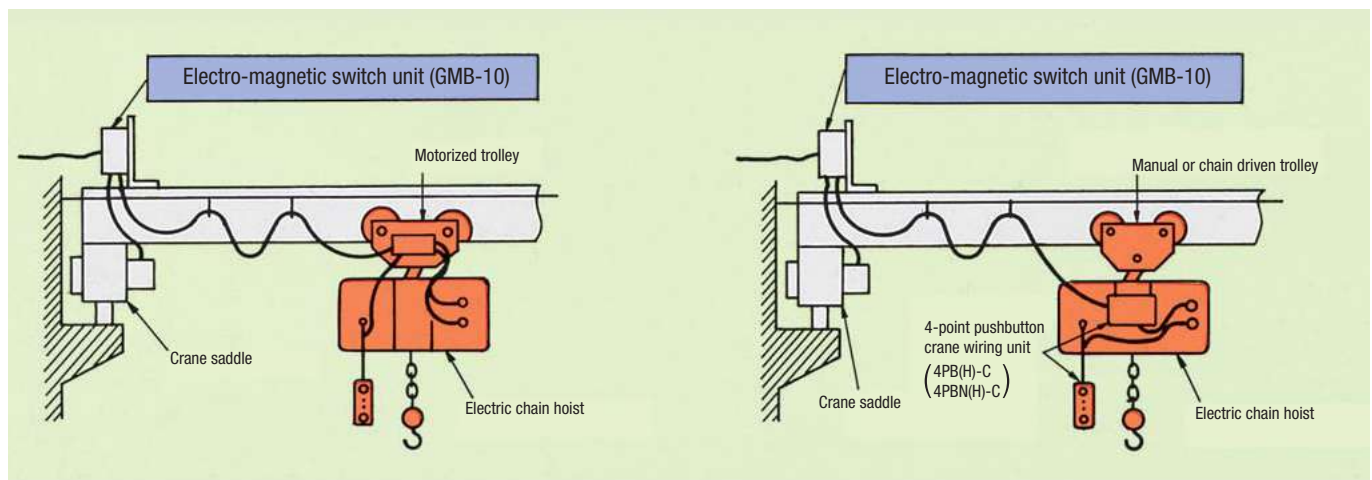

Specifications table

Model Name	GMB-10	
Electro-magnetic Contactor	Type	HMU-12
	Control Voltage	24V
	Current Capacity	10A
Approx. Weight		4kg

Dedicated electric chain hoist

Others

Twin hook type electric chain hoist

The HITACHI twin hook type electric chain hoist is a two-chain, two-hook type with two chain hoists in the same sprocket axis. Since there is 1 chain hoist drive, the load is kept level during hoisting. This is optimal for long items that must be hoisted from 2 points and cargo that must be kept level.



Basic specifications table

Model (main unit)		1/4SHT	1/2SHT	1SHT	1FHT	2FHT
Rated Load		125kg×2	250kg×2	500kg×2	500kg×2	1000kg×2
Standard Lift (m)		6				
Hoisting Speed (m/min)	50Hz	9.2	7.1	4.6	7.1	6.8
	60Hz	11	8.5	5.5	8.5	8.2
Traveling Speed (m/min)	50Hz	10.5				
	60Hz	12.5				
Hoisting Motor (kW)	50Hz	0.4	0.65	0.8	1.3	2.4
	60Hz	0.5	0.8	1.0	1.6	2.9
Traveling Motor (kW)	No. of poles	2				
	50Hz	0.14				
	60Hz	0.16				
	No. of poles	4				
Link Chain (dia./falls)		φ7.1 × 2				φ10 × 2

* A load must always be applied to the lower hook P side, so please inform HITACHI when a original sling will not be used.

Dimensions

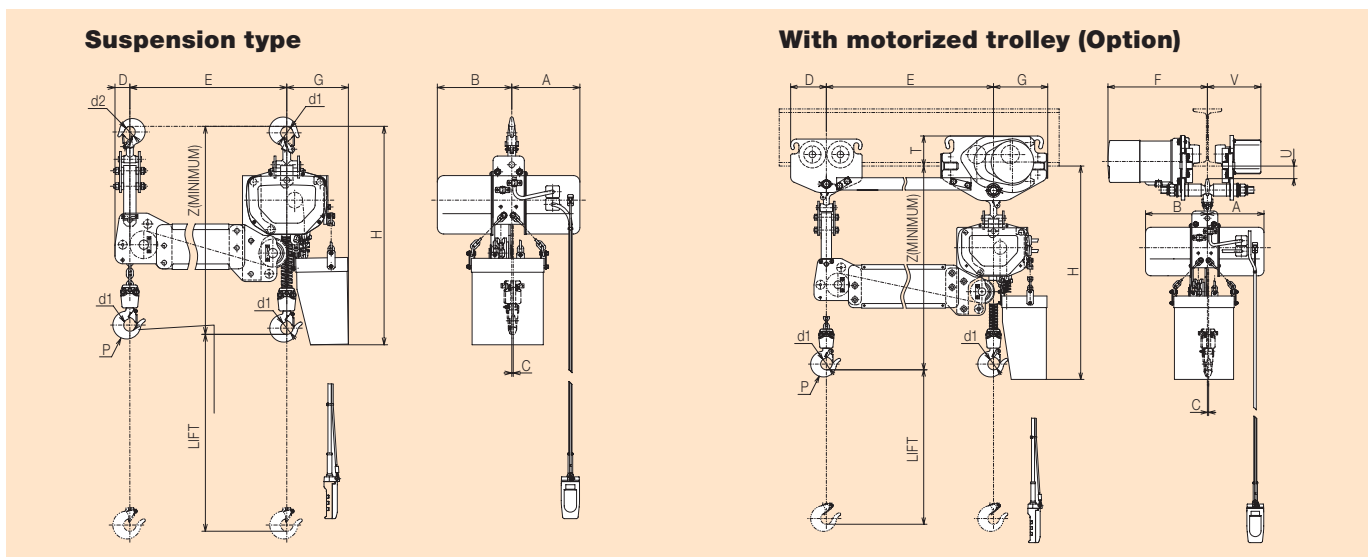

Specifications table

Chain Hoist Model Name		1/4SHT	1/2SHT	1SHT	1FHT	2FHT				
Trolley Type		1ET				2ET				
Dimensions (mm)	A	212			246	286				
	B	252			286	339				
	C	5			5	6				
	D	125(48)			125(48)	125(61)				
	φ d ₁	40			40	45				
	φ d ₂	35.5			35.5	40				
	E	500–2,000(50 Interval) The actual dimensions differ slightly.								
	F	341	353	366	341	353	366			
	G	190(170)			190(170)					
	V	174	187	199	174	187	199			
	T	110					140			
U	38					18				
With Motorized Trolley	H	837	836	834	837	836	834	992	989	980
	Z	744	743	741	744	743	741	877	874	865
Suspension	H	765			765			925		
	Z	672			672			810		
Applicable Beam Width (mm)		75–125			75–125			100–150		

* The suspension type is shown in parentheses ().

* Only the straight rail is applicable to the trolley.

Outline

S series

F series

Others

Dedicated electric chain hoist

Low head room type

The HITACHI low head room type has a smaller Z dimension (minimum distance between the rail bottom surface and the lower hook) making it effective for work that hoists the cargo as high as possible in structures with a low ceiling.

Hoist type	1/2SL	1SL	1FL	2FL	2.8FL	1/2SNL	1SNL	2FNL	2.8FNL	
Trolley type	1ET		2ET	3ET	1ET		2ET	3ET		
Hoisting Speed (m/min)	50Hz	7.1	4.6	7.1	6.8	4.1	7.1/1.8	4.6/1.2	6.8/1.7	4.1/1.0
	60Hz	8.5	5.5	8.5	8.2	4.9	8.5/2.1	5.5/1.4	8.2/2.1	4.9/1.2
Traveling Speed (m/min)	50Hz	10.5				10.5				
	60Hz	12.5				12.5				
Link Chain	Diameter	φ7.1	φ7.1	φ7.1	φ10	φ10	φ7.1	φ7.1	φ10	φ10
	No. of falls	1	1	1	1	2	1	1	1	2
Dimensions (mm)	Z	440	440	440	552	680	440	440	552	680
	A	846	846	846	1,080	1,160	846	846	1,080	1,160

* Traverse only supports linear travel.

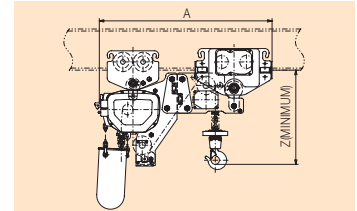

Optional power source electric chain hoist and trolley

When the power source specifications differ, the following power source products will be manufactured.

50Hz	240V, 440V, 500V
60Hz	230V, 380V, 550V

Optional control voltage model

The HITACHI electric chain hoist control voltage is 24V, but products with a specified operating voltage can be manufactured when they must match the voltage of other devices.

Control voltage	100V 50/60Hz, 200V 50/60Hz
------------------------	----------------------------

Electric chain hoist with the Hi-plated chain

This comes with a corrosion-resistant Hi-plated chain. The chain specifications and strength are those of a power chain.

Hi-plated chain	Electroless nickel plating (Chemical resistance strengthening treatment, Plating thickness 8 μm)
------------------------	---

Electric chain hoist with overload prevention unit (with OL)

The HITACHI electric chain hoist that employs an "overload protection unit" was produced in response for demand for increased safety.

Features

- Allows cargo handling work while preventing overloading.
- The operation load remains stable even after repeated operation.
- This device was designed to avoid excessive shocks to ensure a long useful life.
- It is an electromechanical type, so it can support optional power source specifications.

Operation principles

Operation of the detection unit built into the reduction gear shuts off the hoist operation circuit. This is HITACHI's unique "overload prevention unit". It detects overload operation and then stops operation while keeping the load hoisted.

* Lowering operation is possible after the overload prevention device operates.
First push the lowering button once before beginning the operation.



Operation load : 110 to 140%

With geared limit switch (UDS)

- This type has a built-in switch (UDS switch) that allows the upper and lower limit stop positions to be freely set and that outputs signals of a mid points and other locations by detecting the motor speed.
- From 2 to 8 contacts is possible.
2 of the contacts are used for the upper and lower limit switches. Unless otherwise specified, both the upper and lower limits are set at the time of shipment to be activated approximately 100 mm in front of the limit switch built into the main unit.

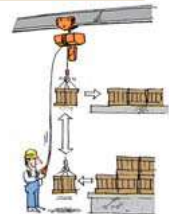

Traverse double speed motorized trolley series

This is suitable for applications requiring a stop system and efficient operation.

Specifications table

Trolley type	1ETN	2ETN	3ETN	5ETN
Rated load	1t	2t	3t	5t
Rating	20%ED, 120Starts/h			
Applicable Beam Width (mm)	75-125	100-150		125-175

For a speed ratio of 4:1

Trolley type	1ETN	2ETN	3ETN	5ETN
Traveling Speed (m/min)	50Hz	21/5.3		
	60Hz	25/6.3		
Motor Output (kW)	50Hz	0.27/0.07	0.6/0.15	
	60Hz	0.32/0.08	0.7/0.18	
No. of poles	2/8			

For a speed ratio of 2:1

Trolley type	1ETN	2ETN	3ETN	5ETN
Traveling Speed (m/min)	50Hz	21/10.5		
	60Hz	25/12.5		
Motor Output (kW)	50Hz	0.27/0.14	0.6/0.3	
	60Hz	0.32/0.16	0.7/0.35	
No. of poles	2/4			

* When specifying a transverse double speed motorized trolley, the pushbutton switch configuration differs depending on whether the hoist unit and travel crane saddle are single speed or double speed, so contact HITACHI.

* The total value for low speed and high speed is shown for the rating.

Other products with changed specifications

Lift change (extension)

- The lift can be extended within the range in the following table, so specify as needed.
- Options other than those shown in the following table are also possible depending on the conditions, so contact HITACHI.

Chain Length and Chain Container

It is necessary to use a chain container of a capacity fitted to the length of chain to be contained.

	Rated Load(kg)	Chain System	Chain Length(m)	Lift (m) and Name of Container																							
				3	4	5	6	7	8	9	10	11	12	13	14	15	16	17	18	19	20	21	22	23	24		
S Series	250	φ6.3 × 1	LIFT+0.5				Ax									Bx							Cx				
	500	φ6.3 × 1	LIFT+0.5				Ax								Bx								Cx				
	1,000	φ7.1 × 1	LIFT+0.7			D						E								F							
	2,000	φ7.1 × 2	2× LIFT+1.4	D		E					F					G											
	3,000	φ7.1 × 3	3× LIFT+2.4	E		F				G																	
F Series	5,000	φ7.1 × 5	5× LIFT+3.9	F		G																					
	1,000	φ7.1 × 1	LIFT+0.7			D						E								F							
	2,000	φ10 × 1	LIFT+0.8	E		F									G								I				
	3,000	φ10 × 2	2× LIFT+1.6	F		G										I											
	5,000	φ10 × 3	3× LIFT+1.8	G																							

Tropical treatment added

The motor is varnish treated twice when it will be subjected to high humidity conditions.

Insulation grade change

The standard product uses E grade insulation, but F grade insulation is possible (motor only).

On beam first stage

The ET trolley beam width is one grade higher than the standard.

With protective cover

This is a resin coated cloth main unit protective cover.

Upper hook direct connection type

This type directly connects the trolley and hoist body using an I-hook.

Optional chain container

Plastic is the standard specification, but it can also be made of steel plate.

With thermal protector

This product can come with a thermal protector to prevent motor burnout.

Technical materials

Power cable allowable length

The power cable allowable length for the standard specification is shown in the following table. When extending the power cable or relay cable, make a selection after referring to the following table.

Allowable Power Cord Length

When extending power cord, cord length should be less than the values in this Table.

(m)

Rated Load (kg)	Cable Size																
	0.75mm ²		AWG #18		1.25mm ²		AWG #16		2.0mm ²		AWG #14		AWG #12		3.5mm ²		
	Hoist only	With Motor Trolley	Hoist only	With Motor Trolley	Hoist only	With Motor Trolley	Hoist only	With Motor Trolley	Hoist only	With Motor Trolley	Hoist only	With Motor Trolley	Hoist only	With Motor Trolley	Hoist only	With Motor Trolley	
S	250	31	27	34	29	52	45	54	47	74	52	76	54	—	—	—	—
	500	27	20	29	21	46	33	48	34	74	52	76	54	—	—	—	—
F	1,000–5,000	27	20	29	21	46	33	23	18	74	52	76	54	118	86	125	92
	1,000	13	10	14	11	22	18	11	8	35	29	36	30	57	48	61	51
	2,000–5,000	—	—	—	—	—	—	—	—	17	13	17	13	28	21	30	23
	10,000–20,000	—	—	—	—	—	—	—	—	8	6	—	—	14	10	15	11

* The length is calculated using 40V for the drop amount where the voltage drop only occurs in the cable. (For a power source of 400V)

About the method with a stopper

Wheel stopper

After the trolley has been installed on the travel rail, always install a stopper on the end of the travel rail to prevent the trolley from dropping off.

- Avoid using the stopper to stop the trolley by letting it run into the stopper.
- Using a stopper that is a different color from the travel rail is an effective means for preventing the trolley from striking the stopper because it makes the stopper stand out.

Damper

The stopper should be used with rubber or other shock absorbing material to absorb the shock when the trolley strikes the stopper. The rubber damper shown in the figure at right is available, so please make use of it.

Installation of trolley stopper

Runway Beam Width (mm)	Materials (L Shaped Rolled Steel Bar)	H (mm)	Bolts and Nuts
75	50×50×6	30	M10
100		40	M16
125		50	
150	65×65×6	60	M20
175		65	

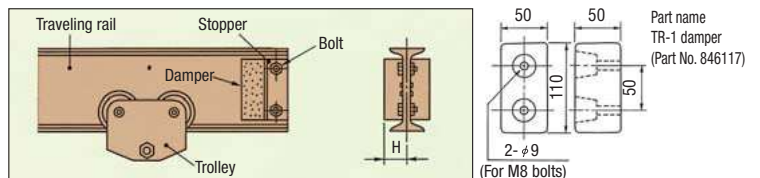

Network

Hitachi Industrial Equipment Systems Co., Ltd. meets customers' needs through the total network which can supply speedy design, production, sales, service and engineering for industrial equipment and systems.

Global Sales Network

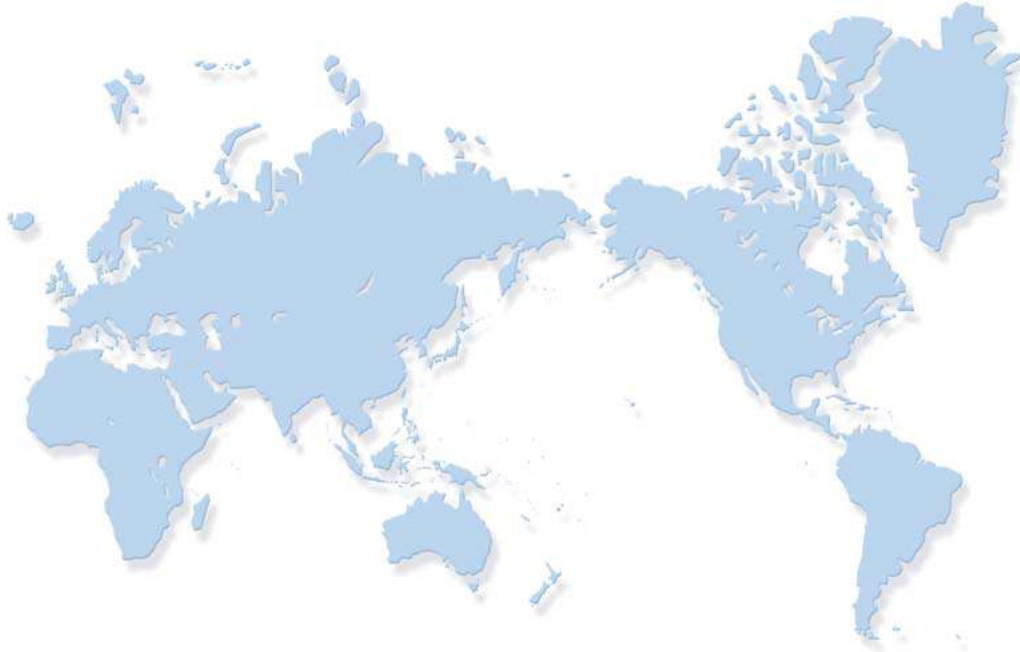

Europe Germany

Hitachi Europe GmbH
Industrial Components & Equipment Group
Am Seestern 18 (Euro Center)
D-40547 Düsseldorf
P.O.BOX 110536.40545 Düsseldorf
TEL: +49 (211) 5283 0
FAX: +49 (211) 5283 649

Asia & Oceania Australia

Hitachi Australia Ltd.
Level 3, 82 Waterloo Road,
North Ryde, N.S.W. 2113
TEL: +61 (2) 9888-4100
FAX: +61 (2) 9888-4188

China

Hitachi East Asia Ltd.
4th Floor, North Tower World Finance Centre,
Harbour City, Canton Road,
Tsim Sha Tsui, Kowloon Hong Kong.
TEL: +852 2735-9218
FAX: +852 2735-6793

(Shanghai Office) (Hitachi (Shanghai) Trading Co., Ltd.)

14th Floor, Rui Jin Building No. 205,
Maoming Road (S) Shanghai, 200020
TEL: +86 (21) 6472-1002
FAX: +86 (21) 6472-4990

(Taipei Branch)

3rd Floor, Hung Kuo Building No. 167
Tun-Hwa North Road, Taipei (105) Taiwan
TEL: +886 (2) 2718-3666
FAX: +886 (2) 2718-8180

Indonesia

Hitachi Asia Ltd. (Jakarta Office)
10th Floor, Mid Plaza 1, JL. Jend.
Sudirman Kav. 10-11, Jakarta 10220
TEL: +62 (21) 574-4313
FAX: +62 (21) 574-4312

Singapore

Hitachi Asia Ltd.
24 Jurong Port Road, #03-05 Office Block,
CWT Distripark Singapore 619097
TEL: +65 (6305) 7400
FAX: +65 (6305) 7401

Thailand

Hitachi Asia (Thailand) Co., Ltd.
18th Floor, Ramaland Building, 952
Rama IV Road Bangrak, Bangkok 10500
TEL: +66 (2) 632-9292
FAX: +66 (2) 632-9299

Information in this brochure is subject to change without notice.

Hitachi Industrial Equipment Systems Co., Ltd.

For further information, please contact your nearest sales representative.

The business facilities and other establishments of Hitachi Equipment Systems Co., Ltd. are certified under ISO 14001 (the international standard for environmental management systems).



JACO-EC97J1095 Narashino Division
JACO-EM5428 Nakajo Division
JACO-EC97J1107 Air Compressor System Division
JACO-EC98J2009 Energy Saving Systems Division
Principal Office
JQA-EM0449 Service station (50 Hz region)
Kansai Business Facility

In terms of quality, the company is certified under ISO 9001 (the international for quality management system) and works to provide high quality in goods and service.