

CABLE TRUNKING SYSTEM

STRAIGHT TRUNKING



STANDARD LENGTH : 2,44 MM.

MATERIAL : SHEET STEEL

FINISHING : EC (EPOXY POWDER COATING)

HD (HOT DIPPED GALVANISED)

AL (ALUZINC)

ZI (ZINC)

COLOR : DARK GRAY, WHITE, ETC.

THICKNESS : 1.0, 1.2, 1.5, 1.6, 2.0 MM

Code No.	Width (mm.)	Height (mm.)	Length (mm.)
UI-W / WW-202	50	50	2,440
UI-W / WW-302	75	50	2,440
UI-W / WW-402	100	50	2,440
UI-W / WW-403	100	75	2,440
UI-W / WW-404	100	100	2,440
UI-W / WW-604	150	100	2,440
UI-W / WW-606	150	150	2,440
UI-W / WW-804	200	100	2,440
UI-W / WW-806	200	150	2,440
UI-W / WW-1004	250	100	2,440
UI-W / WW-1006	250	150	2,440
UI-W / WW-1204	300	100	2,440
UI-W / WW-1206	300	150	2,440
UI-W / WW-1208	300	200	2,440



บริษัท ซีที อิเล็กทริก ซัพพลาย จำกัด
CT ELECTRIC SUPPLY CO., LTD.

โทร : 02 550 9555

CABLE TRUNKING SYSTEM ACCESSORIES

HORIZONTAL ELBOW

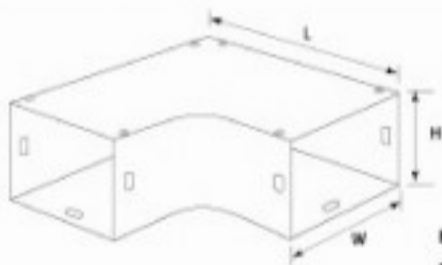
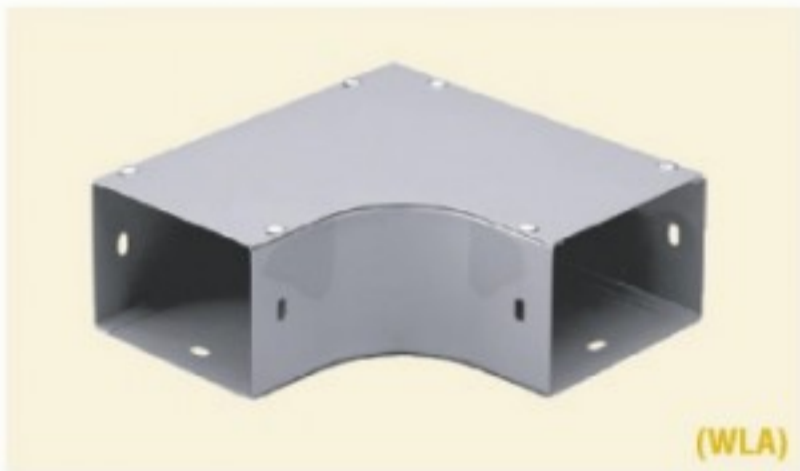

MATERIAL : SHEET STEEL

FINISHING : EC (EPOXY POWDER COATING)

HD (HOT DIPPED GALVANISED)

AL (ALUZINC)

ZI (ZINC)

COLOR : DARK GRAY, WHITE, ETC.

THICKNESS : 1.0, 1.2, 1.5, 1.6, 2.0 MM

Code No.	Width (mm.)	Height (mm.)	Length (mm.)
UI-W / WLA-202	50	50	180
UI-W / WLA-302	75	50	205
UI-W / WLA-402	100	50	230
UI-W / WLA-403	100	75	230
UI-W / WLA-404	100	100	230
UI-W / WLA-604	150	100	280
UI-W / WLA-606	150	150	280
UI-W / WLA-804	200	100	330
UI-W / WLA-806	200	150	330
UI-W / WLA-1004	250	100	380
UI-W / WLA-1006	250	150	380
UI-W / WLA-1204	300	100	430
UI-W / WLA-1206	300	150	430
UI-W / WLA-1208	300	200	430

INSIDE VERTICAL RISER

Code No.	Width (mm.)	Height (mm.)	Length (mm.)
UI-W / WRI-202	50	50	180
UI-W / WRI-302	75	50	180
UI-W / WRI-402	100	50	180
UI-W / WRI-403	100	75	205
UI-W / WRI-404	100	100	230
UI-W / WRI-604	150	100	230
UI-W / WRI-606	150	150	280
UI-W / WRI-804	200	100	230
UI-W / WRI-806	200	150	280
UI-W / WRI-1004	250	100	230
UI-W / WRI-1006	250	150	280
UI-W / WRI-1204	300	100	230
UI-W / WRI-1206	300	150	280
UI-W / WRI-1208	300	200	330



(WRI)

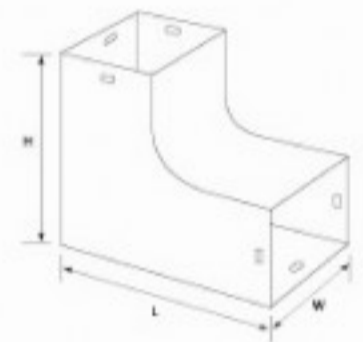

MATERIAL : SHEET STEEL
FINISHING : EC (EPOXY POWDER COATING)
 HD (HOT DIPPED GALVANISED)
 AL (ALUMINUM)
 ZI (ZINC)
COLOR : DARK GRAY, WHITE, ETC.
THICKNESS : 1.0, 1.2, 1.5, 1.8, 2.0 MM.



บริษัท ซีที อิเล็กทริก ซัพพลาย จำกัด
 CT ELECTRIC SUPPLY CO., LTD.

OUTSIDE VERTICAL RISER

โทร : 02 550 9555

Code No.	Width (mm.)	Height (mm.)	Length (mm.)
UI-W / WRO-202	50	50	180
UI-W / WRO-302	75	50	180
UI-W / WRO-402	100	50	180
UI-W / WRO-403	100	75	205
UI-W / WRO-404	100	100	230
UI-W / WRO-604	150	100	230
UI-W / WRO-606	150	150	280
UI-W / WRO-804	200	100	230
UI-W / WRO-806	200	150	280
UI-W / WRO-1004	250	100	230
UI-W / WRO-1006	250	150	280
UI-W / WRO-1204	300	100	230
UI-W / WRO-1206	300	150	280
UI-W / WRO-1208	300	200	330



(WRO)



MATERIAL : SHEET STEEL
FINISHING : EC (EPOXY POWDER COATING)
 HD (HOT DIPPED GALVANISED)
 AL (ALUMINUM)
 ZI (ZINC)
COLOR : DARK GRAY, WHITE, ETC.
THICKNESS : 1.0, 1.2, 1.5, 1.8, 2.0 MM.

HORIZONTAL TEE



(WWT)

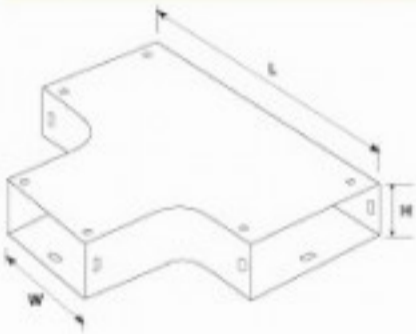

- MATERIAL** : SHEET STEEL
FINISHING : EC (EPOXY POWDER COATING)
 HD (HOT DIPPED GALVANISED)
 AL (ALUZINC)
 ZI (ZINC)
COLOR : DARK GRAY, WHITE, ETC.
THICKNESS : 1.0, 1.2, 1.5, 1.8, 2.0 MM

Code No.	Width (mm.)	Height (mm.)	Length (mm.)
UI-W / WWT-202	50	50	310
UI-W / WWT-302	75	50	335
UI-W / WWT-402	100	50	360
UI-W / WWT-403	100	75	360
UI-W / WWT-404	100	100	360
UI-W / WWT-604	150	100	410
UI-W / WWT-606	150	150	410
UI-W / WWT-804	200	100	460
UI-W / WWT-806	200	150	460
UI-W / WWT-1004	250	100	510
UI-W / WWT-1006	250	150	510
UI-W / WWT-1204	300	100	560
UI-W / WWT-1206	300	150	560
UI-W / WWT-1208	300	200	2440



บริษัท ซีที อิเล็กทริก ซัพพลาย จำกัด
 CT ELECTRIC SUPPLY CO., LTD.

HORIZONTAL CROSSES

โทร : 02 550 9555

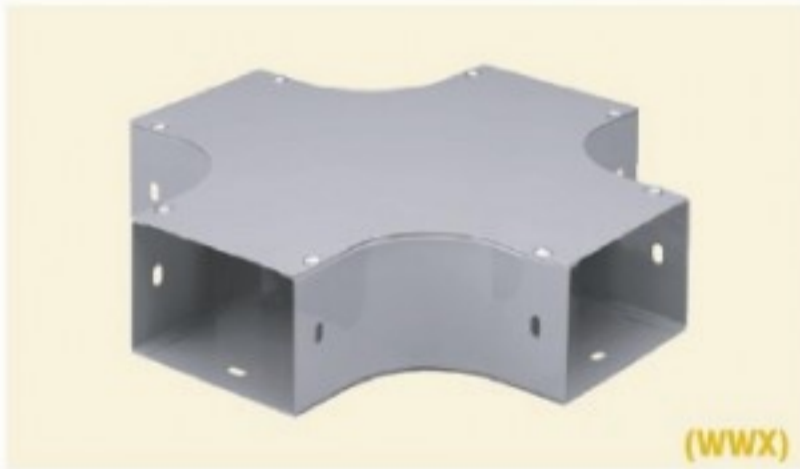

(WWX)

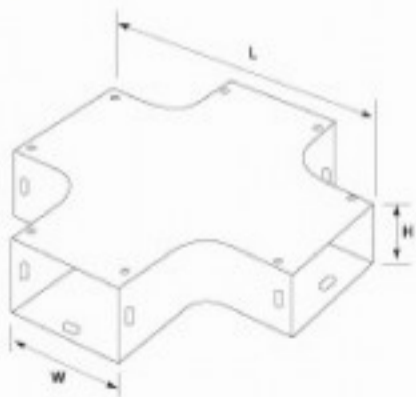

- MATERIAL** : SHEET STEEL
FINISHING : EC (EPOXY POWDER COATING)
 HD (HOT DIPPED GALVANISED)
 AL (ALUZINC)
 ZI (ZINC)
COLOR : DARK GRAY, WHITE, ETC.
THICKNESS : 1.0, 1.2, 1.5, 1.8, 2.0 MM

Code No.	Width (mm.)	Height (mm.)	Length (mm.)
UI-W / WWX-202	50	50	310
UI-W / WWX-302	75	50	335
UI-W / WWX-402	100	50	360
UI-W / WWX-403	100	75	360
UI-W / WWX-404	100	100	360
UI-W / WWX-604	150	100	410
UI-W / WWX-606	150	150	410
UI-W / WWX-804	200	100	460
UI-W / WWX-806	200	150	460
UI-W / WWX-1004	250	100	510
UI-W / WWX-1006	250	150	510
UI-W / WWX-1204	300	100	560
UI-W / WWX-1206	300	150	560
UI-W / WWX-1208	300	200	560

PULL BOX

Code No.	Size INC.
UI - SPB - 001	6" x 6" x 4"
UI - SPB - 001	6" x 8" x 4"
UI - SPB - 001	8" x 8" x 4"
UI - SPB - 001	8" x 10" x 4"
UI - SPB - 001	10" x 10" x 4"
UI - SPB - 001	10" x 12" x 4"
UI - SPB - 001	12" x 12" x 4"
UI - SPB - 001	14" x 14" x 4"
UI - SPB - 001	6" x 6" x 4"
UI - SPB - 001	8" x 8" x 4"
UI - SPB - 001	10" x 10" x 4"
UI - SPB - 001	12" x 12" x 4"
UI - SPB - 001	14" x 14" x 4"
UI - SPB - 001	16" x 16" x 6"



MATERIAL : SHEET STEEL
 FINISHING : EC (EPOXY POWDER COATING)
 HD (HOT DIPPED GALVANISED)
 AZ (ALUZINC)
 Z1 (ZINC)
 COLOUR : DARK GRAY
 THICKNESS : 1.2 X 20 20 20 20 20 20



บริษัท ซีที อีเล็คทริค ซัพพลาย จำกัด

CT ELECTRIC SUPPLY CO., LTD.

โทร : 02 550 9555

C-CHANNEL HANGER ROD

Code No.	Size	Length (mm.)
UI-33/CHD1010	3/8"	1000
UI-33/CHD1015	3/8"	1500
UI-33/CHD1110	1/2"	1000
UI-33/CHD1115	1/2"	1500



HEXAGON COUPLING

Code No.	Size
UI-33/CHC1010	3/8"
UI-33/CHC1015	3/8"

