

42CES Series



The Compact and Practical 42CES Fan Coil Units

The Carrier **42CES** horizontal furred-in Fan Coils are quiet, compact and flexible. Nominal air quantity range from 400 cfm to 1200 cfm. These units are engineered for industrial and commercial applications.

Features

- Ultra-compact design-saves installation space
- High efficiency heat transfer surface
- Super quiet operation
- Low installation and maintenance cost-easy wiring, piping connections
- Installed with direct driven forward curved centrifugal fan and 4-speed high efficient motor
- Minimum power requirement for significant money saving to the owners
- Insulated drain pan
- Factory leak test
- Requires no expensive ductwork
- Ideal for new construction or renovation

Physical Data

Specification (รายละเอียดของเครื่อง)			Chilled Water Coil - Conceal Ducted Type							
Model Name(ชื่อรุ่น) (เครื่องภายใน)	Indoor (เครื่องภายใน)	42CES004W		42CES006W		42CES008W		42CES012W		
		2Rows	3Rows	3Rows	4Rows	3Rows	4Rows	3Rows	4Rows	
Cooling Capacity (ความสามารถในการทำความเย็น)	W	3,930	4,610	5,510	6,160	7,040	8,040	10,090	11,550	
	Btu/hr.	13,400	15,700	18,800	21,000	24,000	27,400	34,400	39,400	
Power Supply (ระบบไฟฟ้า)	V/Ph/Hz	220/1/50								
Operating Current (กระแสไฟฟ้า)	Amp.	0.43		0.65		0.81		1.30		
Power Consumption (กำลังไฟฟ้า)	W	95.00		105.00		170.00		210.00		
Indoor Air Circulation, Max. (ปริมาณลมหมุนเวียน)	CFM	400		600		800		1,200		
Fan Motor	Type	Permanent Split Capacitor / 4 Speed								
	Power Supply	V/Ph/Hz	220/1/50							
	HP	1/2		1/15		1/8		1/15		
	Q'ty	1		1		1		2		
	RLA	Amp.	0.43		0.65		0.81		0.65	
Blower	Type	Centifugal Forward Curve Blade								
	Diameter	mm.	144		144		144		144	
	Width	mm.	188		162		188		162	
	Q'ty	2		2		2		4		
Dimension (ขนาดของเครื่อง)	Width	mm.	990		1,020		1,190		1,730	
	Depth	mm.	470		470		470		470	
	Height	mm.	250		250		250		250	
Gross weight	kg.	22.5		27		29		48.5		
Connecting Pipe (ขนาดท่อที่ใช้)	Water Inlet	inch	5/8		5/8		5/8		5/8	
	Water Outlet	inch	5/8		5/8		5/8		5/8	
	Drain O.D. (ท่อน้ำทิ้ง)(MPT)	inch	3/4		3/4		3/4		3/4	

RLA : Rated Load Amps

MPT : Male Pipe Thread

*Nominal Capacity based on : EAT 80 Fdb/67 Fwb, CHWT 44/54F

Unit dimensions

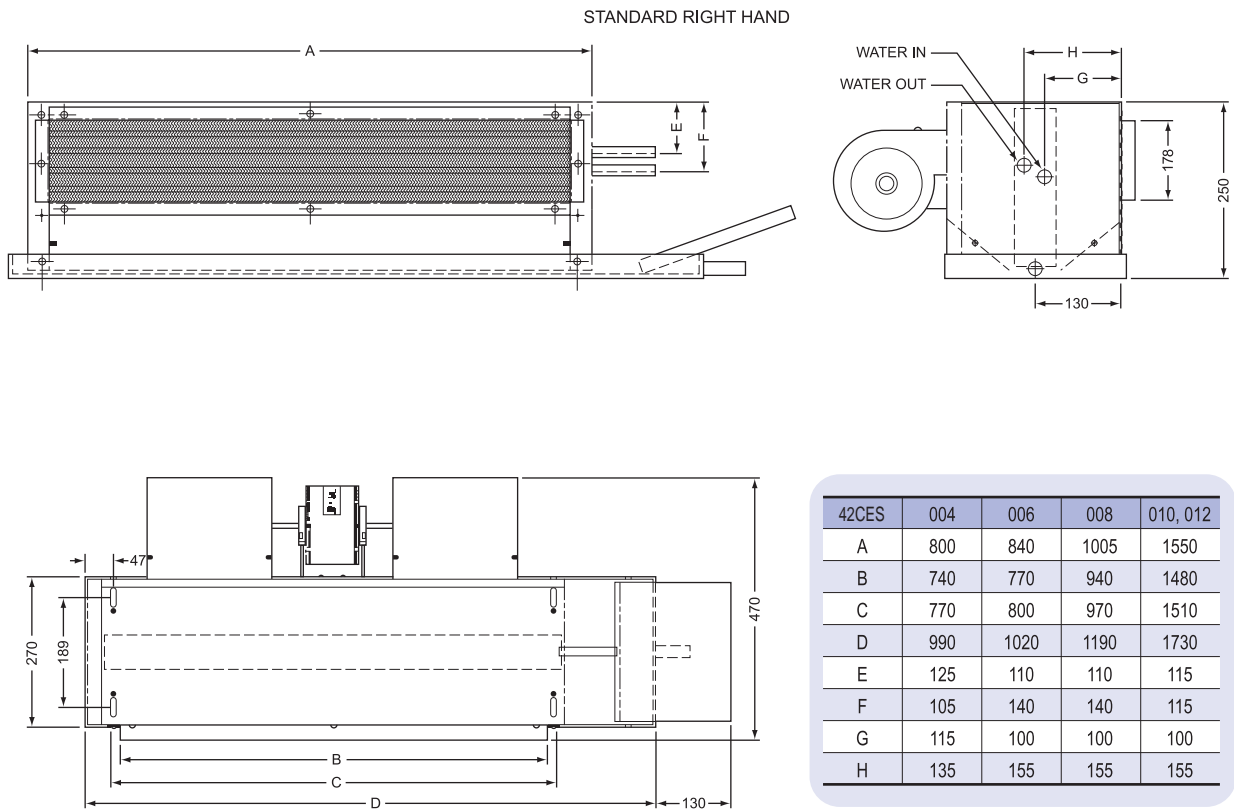

Performance data

Air Delivery (50 Hz)

Model	CFM AT 0.0 ESP			HIGH CFM AT ESP					
	High	Med	Low	0.05	0.10	0.15	0.20	0.25	0.30
42CES004 - 2 rows	630	570	500	560	490	420	345	260	170
42CES006 - 3 rows	870	670	540	800	730	650	570	485	400
42CES008 - 3 rows	1100	790	650	1020	940	850	755	660	550
42CES012 - 3 rows	1500	1050	860	1410	1320	1200	985	840	700
42CES004 - 3 rows	620	560	495	550	480	405	340	250	165
42CES006 - 4 rows	860	660	530	780	710	635	550	470	380
42CES008 - 4 rows	1050	770	640	1000	925	830	740	640	530
42CES012 - 4 rows	1480	970	845	1400	1300	1190	970	830	680

ESP. = External Static Pressure (in. wg)

Notes:

1. Airflow with dry coil conditions.
2. Wet coil cfm is approximately 92% of dry coil cfm.
3. All models without a factory plenum or casing should be operated with a filter and a minimum 0.05 ESP system.

Performance data

2 rows cooling coil for size 004, 3 rows cooling coil for size 006, 008, 012

42°F Enter Water Temperature																
Unit	Entering Temp.(°F)		Water Temperature Rise(°F)													
	WB	DB	6		8		10		12		14		16			
			TH	SH	TH	SH	TH	SH	TH	SH	TH	SH	TH	SH		
004	61	72	11.6	9.0	10.5	8.4	9.3	7.9	8.3	7.3	6.8	6.2	6.2			
006			16.3	12.6	14.7	11.8	13.1	11.0	11.7	10.2	10.3	9.5	8.8	8.7		
008			20.7	15.8	18.7	14.9	16.8	14.0	15.1	13.1	13.5	12.2	11.8	11.4		
012			29.7	22.9	26.8	21.5	23.9	20.2	21.5	18.8	19.1	17.4	16.7	16.1		
004	61	74	11.6	9.7	10.6	9.2	9.7	8.7	8.8	8.2	7.9	7.6	7.0	7.0		
006			16.2	13.6	14.9	12.8	13.5	12.1	12.3	11.4	11.1	10.6	9.9	9.8		
008			20.5	17.0	18.8	16.2	17.1	15.3	15.7	14.5	14.4	13.6	13.0	12.8		
012			29.9	24.9	27.3	23.5	24.8	22.2	22.6	20.9	20.5	19.5	18.4	18.1		
004	63	74	13.7	9.6	12.3	9.0	10.9	8.5	9.7	7.9	8.6	7.3	7.4	6.8		
006			19.1	12.5	17.2	12.2	15.4	11.8	13.7	11.1	12.1	10.3	10.5	9.5		
008			24.1	16.9	21.9	16.0	19.7	15.0	17.8	14.1	15.9	13.2	14.1	12.3		
012			35.0	24.6	31.7	23.2	28.4	21.7	25.5	20.3	22.6	19.0	19.8	17.6		
004	63	76	13.6	10.4	12.3	9.8	11.1	9.3	10.1	8.7	9.0	8.2	7.9	7.7		
006			19.0	14.5	17.3	13.7	15.6	12.9	14.2	12.2	12.7	11.5	11.3	10.7		
008			24.0	18.2	21.9	17.3	19.9	16.3	18.2	15.5	16.6	14.7	15.0	13.8		
012			34.6	26.5	31.5	25.1	28.5	23.6	26.0	22.4	23.6	21.1	21.1	19.8		
004	65	76	15.7	10.3	14.3	9.7	12.9	9.1	11.6	8.5	10.3	7.9	9.0	7.3		
006			21.9	14.3	20.0	13.5	18.2	12.8	16.3	11.9	14.4	11.1	12.5	10.3		
008			27.6	18.0	25.4	17.1	23.2	16.2	21.1	15.2	19.0	14.3	16.9	13.4		
012			40.0	26.2	36.5	24.7	33.0	23.3	29.9	21.4	26.7	19.4	23.5	17.5		
004	65	78	15.7	11.0	14.3	10.4	12.8	9.8	11.7	9.3	10.5	8.7	9.4	8.2		
006			21.8	15.4	19.9	14.6	18.1	13.8	16.4	13.0	14.8	12.2	13.2	11.5		
008			27.5	19.3	25.3	18.4	23.1	17.4	21.2	16.5	19.3	15.7	17.5	14.8		
012			39.9	28.1	36.6	26.6	33.3	25.2	30.4	23.9	27.6	22.5	24.8	21.2		
004	67	80	17.7	11.6	16.4	11.1	15.0	10.5	13.6	9.9	12.3	9.3	10.9	8.8		
006			24.7	16.2	22.9	15.4	21.1	14.7	19.2	13.8	17.4	12.8	15.6	11.9		
008			31.0	20.3	28.9	19.4	26.8	18.5	24.6	17.6	22.5	16.2	20.3	15.7		
012			45.1	29.6	41.6	28.2	38.0	26.8	34.9	25.4	31.7	24.0	28.5	22.6		
004	67	82	17.7	12.4	16.3	11.8	14.9	11.2	13.8	10.7	12.6	10.2	11.4	9.6		
006			24.5	17.2	22.7	16.4	20.9	15.7	19.2	14.9	17.6	14.2	16.0	13.4		
008			30.8	24.2	28.8	23.3	26.8	22.4	25.3	21.6	23.8	20.8	22.4	20.0		
012			45.0	31.5	41.6	30.1	38.2	28.6	35.3	27.3	32.4	26.0	29.5	24.6		
004	69	82	19.9	12.2	18.5	11.7	17.2	11.1	15.7	10.5	14.2	9.9	12.7	9.3		
006			27.6	17.0	25.9	16.3	24.1	15.5	22.1	14.7	20.1	13.9	18.1	13.1		
008			-	-	32.6	20.5	30.6	19.6	28.2	18.7	25.8	17.7	23.5	16.8		
012			-	-	47.3	29.8	44.0	28.4	40.6	27.0	37.1	25.6	33.7	24.2		
004	69	84	19.8	13.0	18.5	12.4	17.2	11.9	15.8	11.3	14.4	10.7	13.0	10.2		
006			27.6	18.1	25.8	17.3	24.0	16.6	22.1	15.8	20.3	15.0	18.4	14.2		
008			-	-	32.6	21.8	30.5	20.9	28.2	20.0	25.9	19.0	23.7	18.1		
012			-	-	47.1	31.7	43.9	30.3	40.5	28.9	37.1	27.5	33.8	26.1		
004	71	84	-	-	20.8	12.3	19.4	11.7	17.9	11.1	16.5	10.6	15.0	10.0		
006			-	-	28.9	17.1	27.2	16.4	25.1	15.6	23.1	14.8	21.1	14.0		
008			-	-	36.4	21.5	34.4	20.7	32.0	19.7	29.7	18.8	27.3	17.9		
012			-	-	52.9	31.3	49.6	29.9	45.9	28.5	42.2	27.0	38.4	25.6		
004	71	86	-	-	20.7	13.0	19.4	12.5	17.9	11.9	16.4	11.3	14.9	10.7		
006			-	-	28.9	18.1	27.1	17.4	25.1	16.6	23.1	15.8	21.1	15.0		
008			-	-	36.4	22.8	34.3	21.9	31.9	21.0	29.6	20.1	27.2	19.1		
012			-	-	52.7	33.2	49.5	31.8	46.0	30.4	42.5	29.0	39.0	27.5		

43°F Enter Water Temperature																
Unit	Entering Temp.(°F)		Water Temperature Rise(°F)													
	WB	DB	6		8		10		12		14		16			
			TH	SH	TH	SH	TH	SH	TH	SH	TH	SH	TH	SH		
004	61	72	10.9	8.7	9.8	8.1	8.8	7.6	7.8	7.0	6.8	6.4	5.8	5.8		
006			15.3	12.1	13.8	11.3	12.3	10.6	10.9	9.8	9.6	9.0	8.3	8.2		
008			19.4	15.2	17.6	14.3	15.7	13.4	14.2	12.5	12.6	11.6	11.1	10.7		
012			27.9	22.1	25.2	20.7	22.5	19.4	20.1	18.0	17.8	16.5	15.5	15.1		
004	61	74	11.0	9.4	10.0	8.9	9.1	8.4	8.3	7.8	7.5	7.2	6.7	6.7		
006			15.4	13.1	14.1	12.4	12.7	11.7	11.6	10.9	10.5	10.1	9.3	9.3		
008			19.4	16.5	17.8	15.6	16.2	14.8	14.9	13.9	13.6	13.0	12.3	12.1		
012			28.2	24.0	25.8	22.7	23.4	21.4	21.4	20.0	19.4	18.6	17.3	17.2		
004	63	74	12.9	9.3	11.6	8.7	10.2	8.2	9.1	7.6	8.0	7.0	6.9	6.5		
006			18.0	12.5	16.2	12.0	14.4	11.4	12.9	10.6	11.3	9.8	9.8	9.1		
008			22.8	16.3	20.6	15.4	18.5	14.5	16.7	13.6	14.9	12.7	13.2	11.8		
012			33.0	23.7	29.8	22.3	26.6	20.9	23.9	19.5	21.2	18.1	18.4	16.7		
004	63	76	12.8	10.0	11.7	9.5	10.5	9.0	9.5	8.4	8.5	7.9	7.5	7.3		
006			17.9	14.0	16.4	13.3	14.8	12.5	13.4	11.8	12.1	11.0	10.7	10.3		
008			22.7	17.6	20.7	16.7	18.8	15.8	17.3	15.0	15.7	14.1	14.1	13.3		
012			32.8	25.6	29.9	24.2	27.0	22.9	24.6	21.6	22.3	20.2	19.9	18.9		
004	65	76	14.9	9.9	13.5	9.4	12.2	8.8	10.9	8.2	9.6	7.6	8.4	7.0		
006			20.8	13.9	18.9	13.1	17.1	12.3	15.3	11.5	13.5	10.7	11.7	9.9		
008			26.2	17.4	24.0	16.5	21.9	15.6	19.8	14.7	17.8	13.7	15.8	12.8		
012			38.0	25.3	34.6	23.9	31.2	22.5	28.1	20.8	25.0	19.1	22.0	17.5		
004	65	78	14.9	10.7	13.5	10.1	12.2	9.5	11.1	9.0	10.0	8.4	8.8	7.9		
006			20.7	14.9	18.9	14.1	17.1	13.3	15.6	12.6	14.0	11.8	12.4	11.0		
008			26.1	18.7	24.0	17.8	21.8	16.9	20.1	16.0	18.3	15.1	16.5	14.3		
012			37.9	27.2	34.7	25.8	31.5	24.4	28.8	23.1	26.0	21.7	23.3	20.4		
004	67	80	16.9	11.3	15.6	10.7	14.2	10.2	12.9	9.6	11.6	9.0	10.3	8.5		
006			23.6	15.7	21.8	15.0	19.9	14.2	18.2	13.4	16.4	12.5	14.6	11.7		
008			29.7	19.8	27.6	18.9	25.4	18.0	23.3	17.1	21.2	16.1	19.2	15.2		
012			43.1	28.8	39.7	27.4	36.2	26.0	33.1	24.6	30.1	23.2	27.0	21.8		
004	67	82	16.9	12.0	15.5	11.5	14.2	10.9	13.1	10.4	12.0	9.8	10.8	9.3		
006			23.5	16.8	21.7	16.0	19.9	15.2	18.3	14.5	16.7	13.8	15.2	13.0		
008			29.6	22.3	27.5	21.4	25.4	20.5	23.8	19.7	22.2	18.9	20.6	18.1		
012			43.0	30.7	39.7	29.2	36.4	27.8	33.6	26.5	30.8	25.2	28.0	23.9		
004	69	82	19.1	11.9	17.7	11.3	16.4	10.8	14.9	10.2	13.5	9.6	12.0	9.0		
006			26.6	16.6	24.8	15.8	23.0	15.1	21.0	14.3	19.0	13.5	17.1	12.7		
008			-	-	31.3	19.9	29.2	19.0	26.8	18.1	24.5	17.2	22.2	16.2		
012			-	-	45.2	28.9	41.9	27.6	38.5	26.2	35.1	24.8	31.7	23.4		
004	69	84	19.0	12.6	17.7	12.1	16.4	11.5	15.0	11.0	13.7	10.4	12.4	9.9		
006			26.5	17.6	24.7	16.9	22.9	16.1	21.1	15.3	19.3	14.6	17.5	13.8		
008			-	-	31.2	21.2	29.1	20.3	26.9	19.4	24.7	18.5	22.5	17.6		
012			-	-	45.1	30.8	41.8	29.5	38.6	28.1	35.3	26.7				

Performance data

3 rows cooling coil for size 004, 4 rows cooling coil for size 006, 008, 012

42°F Enter Water Temperature		Water Temperature Rise(°F)												
Unit	Entering Temp.(°F)		6		8		10		12		14		16	
	WB	DB	TH	SH	TH	SH	TH	SH	TH	SH	TH	SH	TH	SH
004	61	72	13.3	9.7	12.2	9.2	11.1	8.7	10.0	8.2	8.9	7.7	7.8	7.2
006			17.7	13.0	16.3	12.3	14.8	11.6	13.5	11.0	12.2	10.3	10.9	9.7
008			23.4	17.3	21.4	16.4	19.3	15.5	17.4	14.5	15.5	13.5	13.6	12.6
012			33.3	24.4	30.5	23.2	27.7	21.9	25.2	20.6	22.7	19.4	20.1	18.1
004	61	74	13.1	10.5	12.2	10.0	11.3	9.6	10.3	9.1	9.4	8.6	8.5	8.2
006			17.6	13.9	16.3	13.3	15.1	12.7	14.0	12.1	12.9	11.5	11.8	10.9
008			23.2	18.6	21.4	17.7	19.6	16.9	18.0	16.0	16.5	15.1	14.9	14.2
012			33.0	26.3	30.6	25.1	28.2	23.9	26.1	22.8	23.9	21.6	21.8	20.5
004	63	74	15.4	10.4	14.1	9.9	12.9	9.4	12.5	8.8	12.1	8.3	11.7	7.8
006			20.5	13.9	19.0	13.2	17.6	12.5	16.1	11.8	14.5	11.2	13.0	10.5
008			27.0	18.5	24.7	17.5	22.5	16.5	20.5	15.5	18.4	14.6	16.4	13.6
012			38.5	26.1	35.5	24.8	32.5	23.5	29.7	22.2	26.9	20.9	24.1	19.6
004	63	76	15.3	11.2	14.2	10.7	13.0	10.2	12.0	9.7	11.0	9.2	9.9	8.7
006			20.4	14.9	19.0	14.2	17.6	13.6	16.3	13.0	14.9	12.3	13.6	11.7
008			26.9	19.9	24.9	18.9	22.9	18.0	21.0	17.1	19.1	16.2	17.2	15.3
012			38.5	28.1	35.6	26.8	32.8	25.5	30.2	24.3	27.7	23.1	25.1	21.9
004	65	76	-	-	16.4	10.6	15.2	10.1	13.9	9.5	12.7	9.0	11.4	8.5
006			-	-	14.1	20.4	13.5	18.7	12.8	17.0	12.0	15.3	11.3	
008			30.8	19.7	28.7	18.8	26.5	17.8	24.1	16.8	21.8	15.8	19.4	14.8
012			43.8	27.8	41.0	26.6	38.3	25.4	35.0	24.0	31.7	22.6	28.4	21.2
004	65	78	-	-	16.3	11.2	15.1	10.6	14.0	10.2	12.8	9.8	11.7	9.3
006			-	-	15.1	20.2	14.4	18.8	13.8	17.3	13.1	15.8	12.5	
008			30.7	21.1	28.5	20.1	26.3	19.2	24.2	18.2	22.1	17.3	20.1	16.3
012			43.6	29.7	40.8	28.4	37.9	27.2	35.1	25.9	32.3	24.6	29.5	23.4
004	67	80	-	-	18.5	12.0	17.4	11.5	16.1	11.0	14.9	10.5	13.6	9.9
006			-	-	16.0	23.3	15.4	21.7	14.7	20.1	14.0	18.6	13.3	
008			-	-	21.3	30.4	20.4	28.1	19.4	25.9	18.4	23.6	17.4	
012			-	-	30.1	43.7	29.0	40.6	27.6	37.5	26.3	34.3	25.0	
004	67	82	-	-	18.4	12.8	17.3	12.4	16.2	11.9	15.1	11.3	14.0	10.8
006			-	-	16.9	23.1	16.3	21.6	15.7	20.2	15.0	18.7	14.4	
008			-	-	22.7	30.4	21.8	28.2	20.8	26.1	19.9	24.0	18.9	
012			-	-	31.9	43.1	30.7	40.3	29.5	37.6	28.2	34.8	27.0	
004	69	82	-	-	-	-	19.7	12.2	18.4	11.7	17.0	11.1	15.7	10.5
006			-	-	-	-	16.3	24.7	15.6	23.0	14.9	21.3	14.2	
008			-	-	22.5	34.4	21.6	31.9	20.6	29.5	19.5	27.0	18.5	
012			-	-	31.8	49.4	30.6	46.1	29.3	42.8	27.9	39.6	26.5	
004	69	84	-	-	-	-	19.7	12.9	18.4	12.4	17.1	11.9	15.8	11.3
006			-	-	-	-	17.2	24.7	16.6	23.1	15.9	21.6	15.2	
008			-	-	23.8	34.3	22.9	32.0	21.9	29.8	21.0	27.6	20.0	
012			-	-	33.6	49.3	32.5	46.2	31.2	43.1	29.9	40.0	28.6	
004	71	84	-	-	-	-	22.1	12.9	20.8	12.3	19.5	11.8	18.1	11.3
006			-	-	-	-	17.1	27.8	16.4	26.2	15.8	24.6	15.1	
008			-	-	23.6	38.7	22.7	36.3	21.8	33.9	20.8	31.6	19.9	
012			-	-	33.4	55.3	32.2	52.1	30.9	48.8	29.6	45.6	28.3	
004	71	86	-	-	-	-	22.0	13.6	20.7	13.1	19.4	12.5	18.1	12.0
006			-	-	-	-	18.1	54.9	17.4	28.1	16.7	24.4	16.1	
008			-	-	25.0	38.6	24.1	36.2	23.1	33.8	22.1	31.4	21.1	
012			-	-	35.2	55.1	34.1	52.0	32.8	48.8	31.5	45.6	30.2	

43°F Enter Water Temperature		Water Temperature Rise(°F)												
Unit	Entering Temp.(°F)		6		8		10		12		14		16	
	WB	DB	TH	SH	TH	SH	TH	SH	TH	SH	TH	SH	TH	SH
004	61	72	12.5	9.4	11.4	8.9	10.4	8.4	9.4	7.9	8.4	7.4	7.3	6.9
006			16.7	12.5	15.3	11.8	13.9	11.2	12.7	10.5	11.4	9.9	10.2	9.2
008			22.0	16.7	20.0	15.8	18.1	14.8	16.3	13.9	14.5	12.9	12.7	11.9
012			31.3	23.5	28.6	22.3	26.0	21.1	23.6	19.8	21.2	18.5	18.8	17.3
004	61	74	12.4	10.1	11.5	9.7	10.6	9.2	9.8	8.8	8.9	8.3	8.0	7.8
006			16.6	13.5	15.5	12.9	14.3	12.3	13.2	11.7	12.2	11.1	11.1	10.5
008			21.9	18.0	20.2	17.2	18.5	16.3	17.0	15.4	15.5	14.5	14.1	13.5
012			31.2	25.4	29.0	24.0	26.7	23.1	24.6	22.0	22.6	20.8	20.5	19.6
004	63	74	14.6	10.1	13.4	9.5	12.2	9.0	11.5	8.5	10.9	8.0	10.3	7.5
006			19.4	13.4	18.0	12.7	16.5	12.1	15.1	11.4	13.6	10.7	12.1	10.1
008			25.6	17.9	23.4	16.9	21.2	15.9	19.2	15.0	17.2	14.0	15.3	13.0
012			36.5	25.2	33.6	24.0	30.6	22.7	27.9	21.4	25.2	20.1	22.5	18.8
004	63	76	14.5	10.8	13.4	10.3	12.3	9.8	11.3	9.3	9.4	10.3	8.9	9.3
006			19.4	14.4	18.0	13.0	16.6	13.1	15.4	12.5	14.1	11.9	12.8	11.3
008			25.5	19.2	23.6	18.3	21.6	17.4	19.8	16.5	18.0	15.6	16.2	14.7
012			36.4	27.2	33.7	25.9	31.0	24.7	28.6	23.5	26.1	22.3	23.7	21.1
004	65	76	-	-	15.5	10.2	14.3	9.7	13.1	9.2	11.9	8.7	10.6	8.1
006			-	-	13.6	19.3	13.0	17.7	12.3	16.0	11.6	14.4	10.9	
008			29.4	19.1	27.2	18.1	25.0	17.2	22.7	16.2	20.4	15.2	18.1	14.2
012			41.7	26.9	38.9	25.7	36.1	24.5	32.9	23.1	29.8	21.7	26.6	20.4
004	65	78	-	-	15.5	10.9	14.3	10.4	13.2	9.9	12.1	9.5	11.0	9.0
006			-	-	14.6	19.2	14.0	17.8	13.3	16.4	12.7	15.0	12.0	
008			29.3	20.4	27.1	19.5	25.0	18.5	22.9	17.6	20.9	16.7	18.9	15.7
012			41.6	28.8	38.8	27.5	35.9	26.3	33.2	25.1	30.5	23.8	27.8	22.6
004	67	80	-	-	17.7	11.7	16.5	11.2	15.3	10.6	14.1	10.1	12.8	9.6
006			-	-	15.5	22.2	14.9	20.6	14.2	19.1	13.6	17.5	12.9	
008			-	-	20.7	28.9	19.7	26.7	18.8	24.5	17.8	22.3	16.9	
012			-	-	29.2	41.6	28.0	38.5	26.7	35.5	25.4	32.4	24.1	
004	67	82	-	-	17.6	12.4	16.5	12.0	15.4	11.5	14.3	11.0	13.2	10.5
006			-	-	16.5	22.1	15.9	20.6	15.2	19.2	14.6	17.8	14.0	
008			-	-	22.0	28.9	21.1	26.9	20.2	24.8	19.3	22.8	18.4	
012			-	-	31.1	41.2	29.8	38.5	28.6	35.8	27.4	33.1	26.2	
004	69	82	-	-	20.0	12.3	18.9	11.8	17.5	11.3	16.2	10.8	14.8	10.2
006			-	-	16.4	25.2	15.8	23.5	15.1	21.9	14.4	20.2	13.7	
008			-	-	21.8	32.9	20.9	30.5	19.9	28.1	18.9	25.7	17.9	
012			-	-	30.9	47.3	29.7	44.0	28.4	40.8	27.0	37.5	25.7	
004	69	84	-	-	19.9	13.1	18.8	12.6	17.5	12.1	16.3	11.5	15.0	11.0
006			-	-	17.4	25.2	16.8	23.6	16.1	22.0	15.4	20.5	14.8	
008			37.1	24.1	35.0	23.2	32.8	22.3	30.6	21.3	28.4	20.4	26.2	19.4
012			-	-	32.7	47.1	31.6	44.1	30.3	41.1	29.0	38.0	27.7	
004	71	84	-	-	-	-	21.2	12.5	19.9	12.0	18.6	11.4	17.2	10.9
006			-	-	-	-	16.7	26.7	16.0	25.0	15.3	23.3	14.6	
008			-	-	23.0	37.1	22.1	34.7	21.1	31.3	20.2	29.9	19.2	
012			-	-	32.5	53.2	31.4	49.9	30.0	46.6	28.7	43.4	27.4	
004	71	86	-	-	-	-	21.2	13.2	19.9	12.7	18.5	12.2	17.2	11.6
006			-	-	-	-	17.6	37.4	16.9	19.0	16.3	23.3	15.6	
008			-	-	24.3	37.0	23.4	34.6	22.5	32.3	21.5	29.9	20.5	
012			-	-	34.3	53.0	33.2	49.8	31.9	46.7	30.6	43.5	29.3	

44°F Enter Water Temperature		Water Temperature Rise(°F)											

Performance data

Chilled Water Coil Pressure Drop (Δp) (FT of Water)

Cv Factor	Water Flow Rate (GPM)																									
	0.5	1.0	1.5	2.0	2.5	3.0	3.5	4.0	4.5	5.0	5.5	6.0	6.5	7.0	7.5	8.0	8.5	9.0	9.5	10.0	10.5	11.0	11.5	12.0	13.0	14.0
0.8	0.9	3.6	8.1	14.4	22.5	32.4	-	-	-	-	-	-	-	-	-	-	-	-	-	-	-	-	-	-	-	-
0.9	0.7	2.8	6.4	11.4	17.8	25.6	34.9	-	-	-	-	-	-	-	-	-	-	-	-	-	-	-	-	-	-	-
1.0	0.5	2.3	5.2	9.2	14.4	20.7	28.2	36.9	-	-	-	-	-	-	-	-	-	-	-	-	-	-	-	-	-	-
1.1	0.4	1.9	4.2	7.6	11.9	17.1	23.3	30.5	-	-	-	-	-	-	-	-	-	-	-	-	-	-	-	-	-	-
1.2	-	1.6	3.6	6.4	10.0	14.4	19.6	25.6	32.4	-	-	-	-	-	-	-	-	-	-	-	-	-	-	-	-	-
1.3	-	1.3	3.0	5.4	8.5	12.3	16.7	21.8	27.6	34.1	-	-	-	-	-	-	-	-	-	-	-	-	-	-	-	-
1.4	-	1.1	2.6	4.7	7.3	10.6	14.4	18.8	23.8	29.4	-	-	-	-	-	-	-	-	-	-	-	-	-	-	-	-
1.5	-	1.0	2.3	4.1	6.4	9.2	12.5	16.4	20.7	25.6	31.0	-	-	-	-	-	-	-	-	-	-	-	-	-	-	-
1.6	-	0.9	2.0	3.6	5.6	8.1	11.0	14.4	18.2	22.5	27.2	32.4	-	-	-	-	-	-	-	-	-	-	-	-	-	-
1.7	-	0.8	1.8	3.2	4.9	7.1	9.7	12.7	16.1	19.9	24.1	28.7	33.7	-	-	-	-	-	-	-	-	-	-	-	-	-
1.8	-	0.7	1.6	2.8	4.4	6.4	8.7	11.4	14.4	17.8	21.5	25.6	30.1	-	-	-	-	-	-	-	-	-	-	-	-	-
1.9	-	0.6	1.4	2.5	4.0	5.7	7.8	10.2	12.9	15.9	19.3	23.0	27.0	31.3	-	-	-	-	-	-	-	-	-	-	-	-
2.0	-	0.5	1.3	2.3	3.6	5.2	7.0	9.2	11.6	14.4	17.4	20.7	24.4	28.2	32.4	-	-	-	-	-	-	-	-	-	-	-
2.1	-	0.5	1.1	2.0	3.2	4.7	6.4	8.3	10.6	13.0	15.8	18.8	22.1	25.6	29.4	33.5	-	-	-	-	-	-	-	-	-	-
2.2	-	0.4	1.0	1.9	2.9	4.2	5.8	7.6	9.6	11.9	14.4	17.1	20.1	23.3	26.8	30.5	-	-	-	-	-	-	-	-	-	-
2.3	-	-	0.9	1.7	2.7	3.9	5.3	6.9	8.8	10.9	13.2	15.7	18.4	21.3	24.5	27.9	31.5	-	-	-	-	-	-	-	-	-
2.4	-	-	0.9	1.6	2.5	3.7	4.9	6.4	8.1	10.0	12.1	14.4	16.9	19.6	22.5	25.6	28.9	32.4	-	-	-	-	-	-	-	-
2.5	-	-	0.8	1.4	2.3	3.3	4.5	5.9	7.4	9.2	11.1	13.3	15.6	18.1	20.7	23.6	26.7	29.9	33.3	-	-	-	-	-	-	-
2.6	-	-	0.7	1.3	2.1	3.0	4.1	5.4	6.9	8.5	10.3	12.3	14.4	16.7	19.2	21.8	24.6	27.6	30.8	-	-	-	-	-	-	-
2.7	-	-	0.7	1.2	1.9	2.8	3.8	5.0	6.4	7.9	9.5	11.4	13.3	15.5	17.8	20.2	22.8	25.6	28.5	31.6	-	-	-	-	-	-
2.8	-	-	0.6	1.1	1.8	2.6	3.6	4.7	5.9	7.3	8.9	10.6	12.4	14.4	16.5	18.8	21.2	23.8	26.5	29.4	32.4	-	-	-	-	-
2.9	-	-	0.6	1.1	1.7	2.4	3.3	4.3	5.5	6.8	8.3	9.8	11.6	13.4	15.4	17.5	19.8	22.2	24.7	27.4	30.2	-	-	-	-	-
3.0	-	-	0.5	1.0	1.6	2.3	3.1	4.1	5.2	6.4	7.7	9.2	10.8	12.5	14.4	16.4	18.5	20.7	23.1	25.6	28.2	31.0	-	-	-	-
3.2	-	-	0.5	0.9	1.4	2.0	2.7	3.6	4.5	5.6	6.8	8.1	9.5	11.0	12.6	14.4	16.3	18.2	20.3	22.5	24.8	27.2	29.8	-	-	-
3.4	-	-	-	0.8	1.2	1.8	2.4	3.2	4.0	4.9	6.0	7.1	8.4	9.7	11.2	12.7	14.4	16.1	18.0	19.9	22.0	24.1	26.4	28.7	-	-
3.6	-	-	-	0.7	1.1	1.6	2.1	2.8	3.6	4.4	5.3	6.4	7.5	8.7	10.0	11.4	12.8	14.4	16.0	17.8	19.6	21.5	23.5	25.6	30.1	-
3.8	-	-	-	0.6	1.0	1.4	1.9	2.5	3.2	4.0	4.8	5.7	6.7	7.8	9.0	10.2	11.5	12.9	14.4	15.9	17.6	19.3	21.1	23.0	27.0	31.3
4.0	-	-	-	0.5	0.9	1.3	1.7	2.3	2.9	3.6	4.3	5.2	6.1	7.0	8.1	9.2	10.4	11.6	13.0	14.4	15.9	17.4	19.0	20.7	24.4	28.2

Note: Interpolation is permitted; do not extrapolate. To calculate pressure drop for Cv factors and flow rates not shown in the table, use the following formula

$$\Delta P = \frac{(\text{GPM})^2}{(\text{Cv})^2} \times 2.31$$

Chilled Water Coil Cv Factors

Unit Size	2-Row	3-Row	4-Row
42CES004	1.2	0.9	-
42CES006	-	2.4	2.0
42CES008	-	2.2	1.9
42CES012	-	3.2	3.0

Metric conversion chart

Metric Tech	x	=	English Unit	x	=	SI Unit
Area						
cm ²				100		mm ²
cm ²	0,1550		in. ²	645.2		mm ²
m ²				1.0		m ²
m ²	10,76		ft ²	0,09290		m ²
Length						
μm				1.0		μm
μm	39.37		micro-inch	0.0254		μm
mm				1.0		mm
mm	0,03937		in.	25.4		mm
m	0,003281		ft	304.8		m
m				1.0		m
m	3,281		ft	0,3048		m
m	1,094		yd	0,9144		m
Mass						
g				1.0		g
g	0,03527		oz	28.35		g
kg				1.0		kg
kg	2,205		lb	0,4536		kg
tonne, Mg				1.0		tonne, Mg
tonne, Mg	1,102		U.S. ton (2000 lb)	0,9072		tonne, Mg
Power						
kcal/h				1,163		W
kcal/h	3,968		Btu/h	0,2931		W
Hp metric				0,7355		kW
Hp metric	0,9863		HP (550 $\frac{ft \cdot lb}{S}$)	0,7457		kW
Mcal/h				1,163		kW
Mcal/h	0,3307		Ton refr.	3,517		kW
Pressure						
mm w.g. 4°C				9,806		Pa
mm w.g. 4°C	0,03937		in H ₂ O 39,2°F	249,1		Pa
mm Hg 0°C				0,1333		kPa
mm Hg 0°C	0,03937		in Hg 32°F	3,386		kPa
kgf/cm ²				98,07		kPa
kgf/cm ²	14,22		psi	6,895		kPa
mH ₂ O	3,281		ft H ₂ O	2,989		kPa

Prefixes

M	MEGA	- 10 ⁶
k	KILO	- 10 ³
d	DECI	- 10 ⁻¹
c	CENTI	- 10 ⁻²
m	MILLI	- 10 ⁻³
μ	MICRO	- 10 ⁻⁶

Legend

m	METER	K	KELVIN
cal	CALORIE	W	WATT
kg	KILOGRAM (mass)	Pa	PASCAL
kgf	KILOGRAM - FORCE	J	JOULE
L	LITER	N	NEWTON
°C	DEGRESS CELSIUS	h	HOUR

Metric Tech	x	=	English Unit	x	=	SI Unit
Temperature						
Interval						
°C				1.0		K
°C	1,8		°F	0,5556		°C
Velocity						
m/s				1,0		m/s
m/s	3,281		ft/s	0,3048		m/s
m/s	196,9		ft/min	0,00508		m/s
Volume						
mm ³				1,0 x 10 ⁻⁶		L
mm ³	6,102 x 10 ⁻⁵		in. ³	0,01639		L
L				1,0		L
L	0,03531		ft ³	28,32		L
m ³				1,0		m ³
m ³	1,308		yd ³	0,7646		m ³
L	0,2642		U.S. gal	3,785		L
L	2,113		U.S. pint	0,4732		L
mL, cm ³				1,0		mL
mL, cm ³	0,03381		U.S. oz	29,57		mL
Volume/Time						
m ³ /h				0,2778		L/s
m ³ /h	0,5886		ft ³ /min	0,4719		L/s
m ³ /h	4,403		U.S. gal/min	0,06309		L/s
L/h				2,778 x 10 ⁻⁴		L/s
L/h	4,403 x 10 ⁻³		U.S. gal/min	0,06309		L/s
(m ³ /h)/ (1000 kcal/h)	1,780		cfm/ton	0,1342		L/s kw

Metric Tech	Conversion Factor	=	English Unit	Conversion Factor	=	SI Unit
Temperature						
°C				°C + 273,15		K
°C	(°C x 1,8) + 32		°F	(°F - 32) ÷ 1,8		°C

Units

cP	CENTIPOISE	mm Hg	MILLIMETERS MERCURY
cSt	CENTISTOKE	tonne	= 1000 kg
HP metric = (PS, CV, ch)	METRIC HORSEPOWER	kcal	= fg FRIGORIE
mm w.g.	MILLIMETERS WATER GAUGE	bar	= 100 kPa



บริษัท บี.เค.แอร์ซัพพลาย จำกัด
611,613 ถนนพระราม3 แขวงบางโพงพาง เขตยานนาวา กรุงเทพมหานคร 10120
โทรศัพท์ 02-294-5260 02-294-5261 02-284-2826 02-294-2972 โทรสาร 02-294-2973
www.bkairsupply.com email : bkairsupply@hotmail.com LINE ID : Nick_arswin

Carrier reserves the right to make changes in specifications without prior notice.
บริษัทฯ ขอสงวนสิทธิ์ที่จะเปลี่ยนแปลงรายละเอียดข้างต้น โดยไม่ต้องแจ้งให้ทราบล่วงหน้า



YOUR CARRIER MAN :