

# BMS Series Amplifier Built-in Type By Side Sensing

## High Speed Response Type With Built-in Output Protection Circuit

### ■ Features

- Reverse power polarity and overcurrent
- Response time: Max. 1ms
- Light ON/Dark ON mode selectable by control wire
- Sensitivity adjuster (except for through-beam type)

 Please read "Safety Considerations" in operation manual before using.



(MS-2)

(MS-5)

(MST-□)

※MS-5, MST-□ is sold separately.

### ■ Specifications

Model	NPN open collector output	BMS5M-TDT	BMS2M-MDT	BMS300-DDT
	PNP open collector output	BMS5M-TDT-P	BMS2M-MDT-P	BMS300-DDT-P
Sensing type	Through-beam		Retroreflective	Diffuse reflective
Sensing distance	5m		2m <sup>※1</sup>	300mm <sup>※2</sup>
Sensing target	Opaque materials of Min. Ø10mm		Opaque materials of Min. Ø60mm	Translucent, Opaque materials
Hysteresis	—			Max. 20% at rated setting distance
Response time	Max. 1ms			
Power supply	12-24VDC $\pm$ 10% (ripple P-P: max. 10%)			
Current consumption	Max. 50mA		Max. 45mA	
Light source	Infrared LED (940nm)			
Sensitivity adjustment	—		Sensitivity adjuster	
Operation mode	Selectable Light ON or Dark ON by control wire			
Control output	NPN or PNP open collector output ●Load voltage: max. 30VDC $\pm$ ●Load current: max. 200mA ●Residual voltage - NPN: max. 1VDC $\pm$ , PNP: max. 2.5VDC			
Protection circuit	Reverse polarity protection circuit, output overcurrent (short-circuit) protection circuit			
Indicator	Operation indicator: red LED, power indicator: red LED (BMS5M-TDT1)			
Insulation resistance	Over 20MΩ (at 500VDC megger)			
Noise immunity	$\pm$ 240V the square wave noise (pulse width: 1μs) by the noise simulator			
Dielectric strength	1000VAC 50/60Hz for 1minute			
Vibration	1.5mm amplitude at frequency of 10 to 55Hz (for 1 min) in each X, Y, Z direction for 2 hours			
Shock	500m/s <sup>2</sup> (approx. 50G) in each X, Y, Z direction for 3 times			
Environment	Ambient illumination	Sunlight: max. 11,000lx, incandescent lamp: max. 3,000lx		
	Ambient temperature	-10 to 60°C, storage: -25 to 70°C		
	Ambient humidity	35 to 85%RH, storage: 35 to 85%RH		
Material	Case: acrylonitrile butadiene styrene, sensing part: polycarbonate, bracket: steel plate cold commercial, bolt: steel chromium molybdenum, nut: steel chromium molybdenum		Case: acrylonitrile butadiene styrene, sensing part: acryl, bracket: steel plate cold commercial, bolt: steel chromium molybdenum, nut: steel chromium molybdenum	
Cable	Ø5mm, 4-wire, 2m (emitter of through-beam type: Ø5mm, 2-wire, 2m) (AWG22, core diameter: 0.08mm, number of cores: 60, insulator out diameter: Ø1.25mm)			
Accessories	Individual	—	Reflector (MS-2), adjuster driver	Adjuster driver
	Common	Fixing bracket, bolts, nuts		
Approval				
Unit weight	Approx. 180g		Approx. 110g	Approx. 100g

※1: It is sensing distance between sensor and reflector MS-2 and it is the same when MS-5 is used. It is detectable under 0.1m.  
When using reflective tapes, the reflectivity will vary by the size of the tape. Please refer to the "Reflectivity By Reflective Tape Model" table before using the tapes.

※2: Non-glossy white paper 100×100mm.

※The temperature or humidity mentioned in Environment indicates a non freezing or condensation environment.

(A)	Photoelectric Sensors
(B)	Fiber Optic Sensors
(C)	Door/Area Sensors
(D)	Proximity Sensors
(E)	Pressure Sensors
(F)	Rotary Encoders
(G)	Connectors/ Connector Cables/ Sensor Distribution Boxes/ Sockets
(H)	Temperature Controllers
(I)	SSRs / Power Controllers
(J)	Counters
(K)	Timers
(L)	Panel Meters
(M)	Tacho / Speed / Pulse Meters
(N)	Display Units
(O)	Sensor Controllers
(P)	Switching Mode Power Supplies
(Q)	Stepper Motors & Drivers & Controllers
(R)	Graphic/ Logic Panels
(S)	Field Network Devices
(T)	Software

# BMS Series

## ■ Feature Data

### ◎ Through-beam type

- BMS5M-TDT
- BMS5M-TDT-P

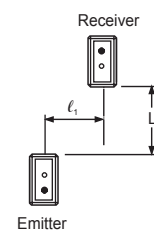
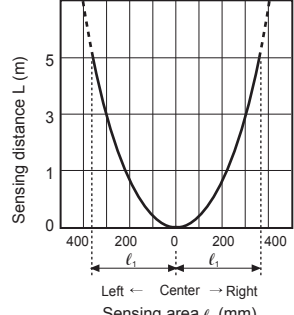
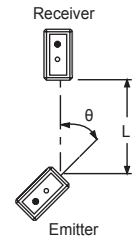
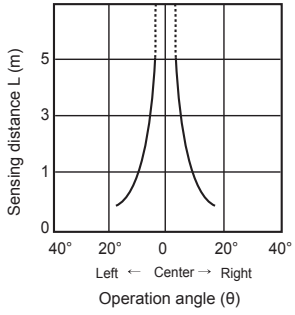
Parallel shifting characteristic		Angle characteristic	
Measuring method	Data	Measuring method	Data
			

### ◎ Retroreflective type

- BMS2M-MDT
- BMS2M-MDT-P

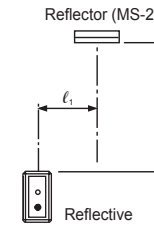
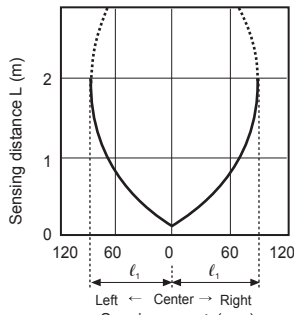
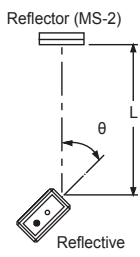
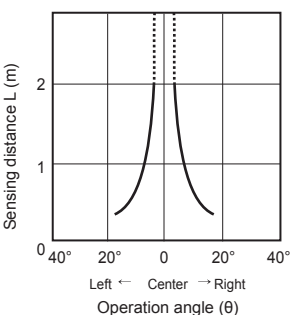
Parallel shifting characteristic		Sensor angle characteristic	
Measuring method	Data	Measuring method	Data
			

### ◎ Retroreflective type

- BMS2M-MDT
- BMS2M-MDT-P

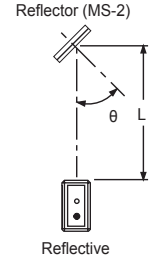
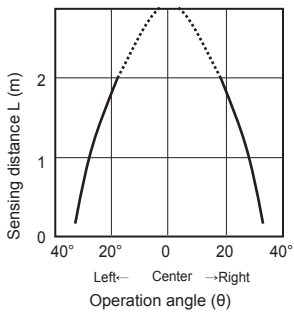
Reflector angle characteristic	
Measuring method	Data
	

### ◎ Diffuse reflective type

- BMS300-DDT
- BMS300-DDT-P

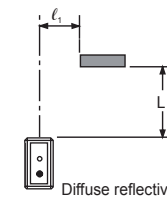
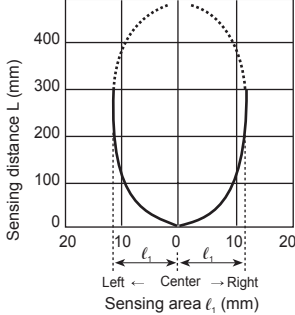
Sensing area characteristic	
Measuring method	Data
<p>Standard sensing target: Non-glossy white paper 100×100mm</p> 	

# Amplifier Built-in Type By Side Sensing

## Control Output Diagram

### • NPN open collector output

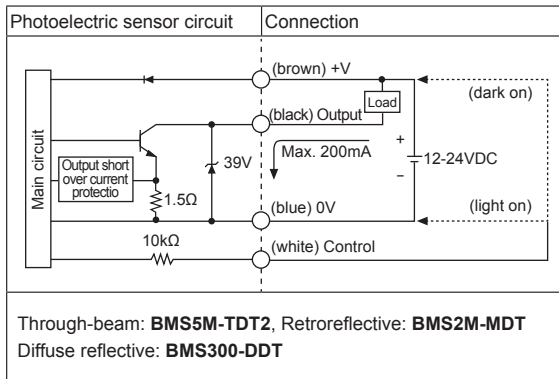

### • PNP open collector output

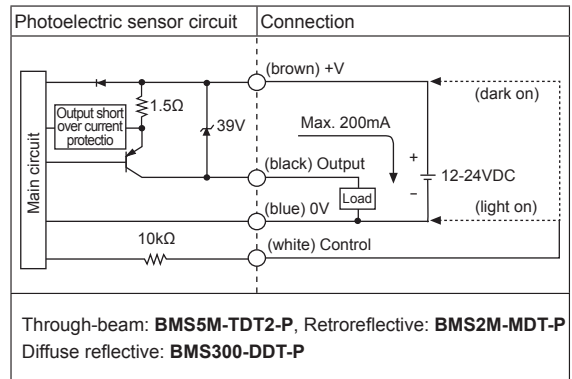

※Select Light ON / Dark ON by control wire. - Light ON: Connect control wire to 0V / Dark ON: Connect control wire to +V

## Operation Mode

Operation mode	Light ON	Dark ON
Receiver operation	Received light Interrupted light	Received light Interrupted light
Operation indicator (red LED)	ON OFF	ON OFF
Transistor output	ON OFF	ON OFF

※To prevent malfunction, this sensor maintains control output OFF for 0.5 sec. after supplying the power.

※If the control output terminal is short-circuited or overcurrent condition exists, the control output turns OFF due to protection circuit.

## Connections

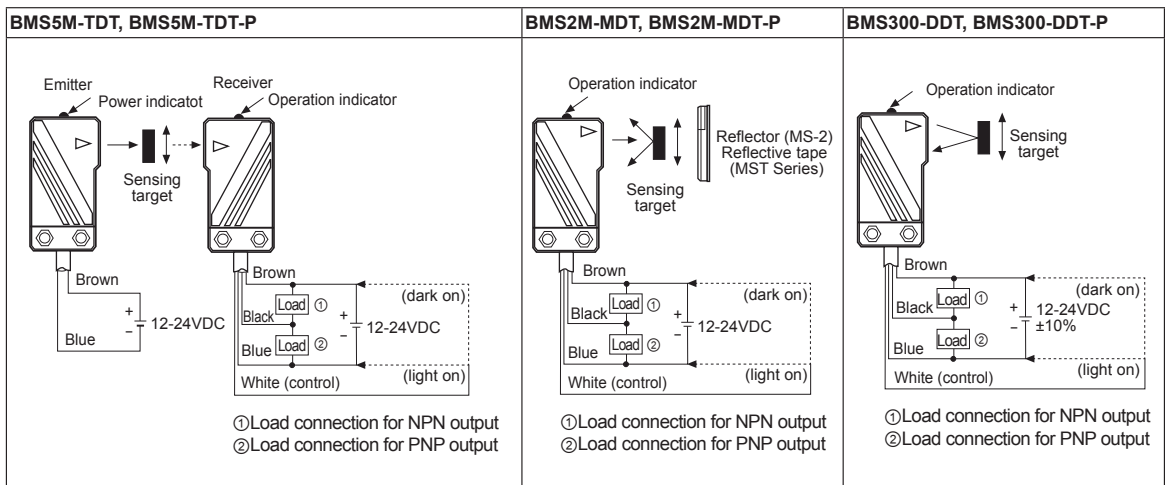

※Dark ON mode is on when control line is opened.

(A) Photoelectric Sensors
(B) Fiber Optic Sensors
(C) Door/Area Sensors
(D) Proximity Sensors
(E) Pressure Sensors
(F) Rotary Encoders
(G) Connectors/ Connector Cables/ Sensor Distribution Boxes/ Sockets
(H) Temperature Controllers
(I) SSRs / Power Controllers
(J) Counters
(K) Timers
(L) Panel Meters
(M) Tacho / Speed / Pulse Meters
(N) Display Units
(O) Sensor Controllers
(P) Switching Mode Power Supplies
(Q) Stepper Motors & Drivers & Controllers
(R) Graphic/ Logic Panels
(S) Field Network Devices
(T) Software

# BMS Series

## ■ Dimensions

(unit: mm)

### ● Connect the bracket

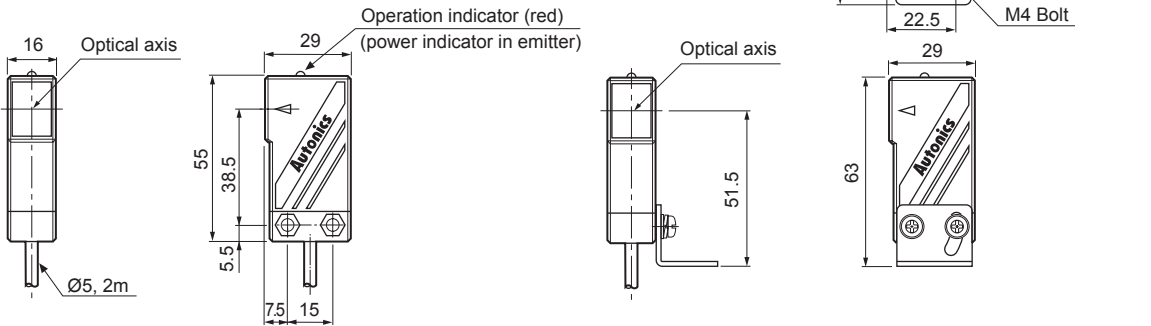

### ● Reflector

#### • MS-2

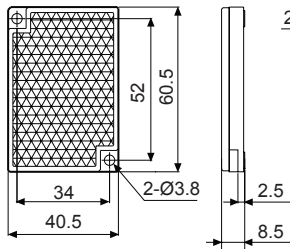

#### • MS-5

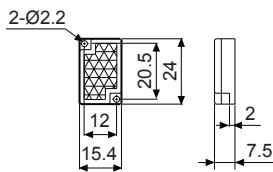

### ● Bracket

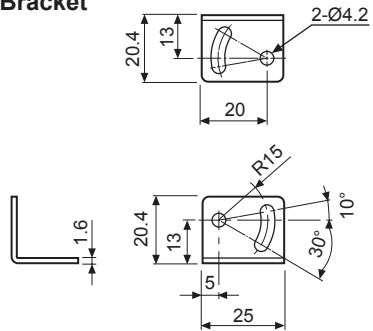

### ● Reflective tape (sold separately)

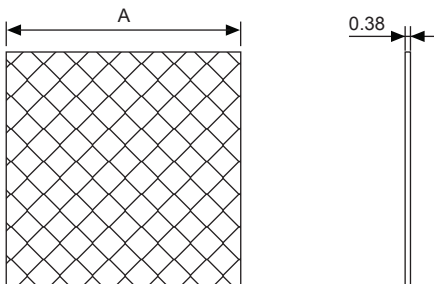

(unit: mm)

Model	A
MST-50-10	□50
MST-100-5	□100
MST-200-2	□200

# Amplifier Built-in Type By Side Sensing

## ■ Mounting and Sensitivity Adjustment

Install the sensor to the desired place and check the connections.  
Supply the power to the sensor and adjust the optical axis and the sensitivity as follow ;

### ◎ Optical axis adjustment

#### ● Through-beam type

Set the photoelectric sensor in the middle of the operation range of the operation indicator by adjusting the receiver or emitter right and left, up and down.

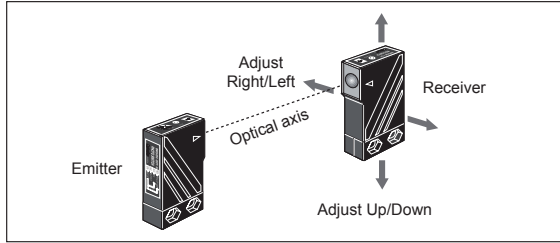

#### ● Retroreflective type

Mount the photoelectric sensor and the reflector or reflective tape facing each other then fix them in the middle of operation range of the operation indicator by adjusting the reflector (or reflective tape) right and left, up and down.

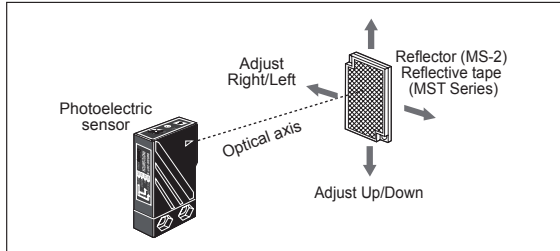

- ※If the mounting place is too narrow, please use MS-5 instead of MS-2.
- ※Please use reflective tape (MST series) for where a reflector is not installed.



#### ● Diffuse reflective type

Mount the photoelectric sensor and the target then fix them in the middle of operation range of the operation indicator by adjusting the photoelectric sensor right and left, up and down.

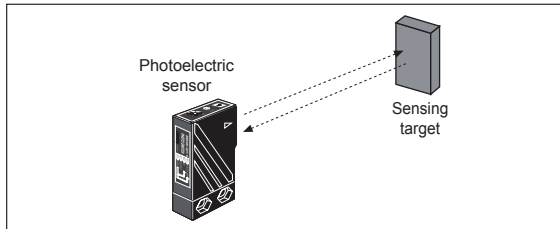

### ◎ Sensitivity adjustment

#### ● Retroreflective type

Fix the sensitivity adjuster at max. position and then check if the sensor operates normally to pass the target within sensing area of the sensor.

If the sensor does not work normally by noise or external light, turn the sensitivity adjuster slowly up to the position.

※If reflectance of target is higher than non-glossy white paper, it might cause malfunction by reflection from the target when the target is near to the photoelectric sensor. Therefore enough space between the target and the photoelectric sensor or the surface of the target should be mounted at angle of 30° to 45° against optical axis.

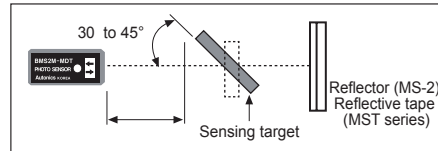

#### ● Diffuse reflective type

Set the target at a position to be detected by the beam, then turn the sensitivity adjuster until position ㊸ where the operation indicator turns ON from min. position of the sensitivity adjuster up to position ㊸ which the operation indicator turn ON from min.

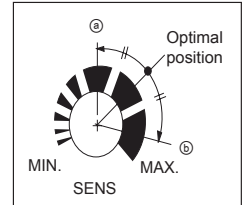

Take the target out of the sensing area, then turn the sensitivity adjuster until position where the indicator turns ON. If position ㊸ is not checked, the max. position is ㊹. Set the sensitivity adjuster in the middle of two switching position ㊸, ㊹.  
※Please be aware not to make the unstable operation of sensor by background and mounting side.

## ■ Reflectivity by Reflective Tape Model

MST-50-10 (50×50mm)	90%
MST-100-5 (100×100mm)	120%
MST-200-2 (200×200mm)	190%

- ※This reflectivity is based on the reflector (MS-2).
- ※Reflectivity may vary depending on usage environment and installation conditions.  
The sensing distance and minimum sensing target size increase as the size of the tape increases.  
Please check the reflectivity before using reflective tapes.
- ※For using reflective tape, installation distance should be min. 20mm.

(A)	Photoelectric Sensors
(B)	Fiber Optic Sensors
(C)	Door/Area Sensors
(D)	Proximity Sensors
(E)	Pressure Sensors
(F)	Rotary Encoders
(G)	Connectors/ Connector Cables/ Sensor Distribution Boxes/ Sockets
(H)	Temperature Controllers
(I)	SSRs / Power Controllers
(J)	Counters
(K)	Timers
(L)	Panel Meters
(M)	Tacho / Speed / Pulse Meters
(N)	Display Units
(O)	Sensor Controllers
(P)	Switching Mode Power Supplies
(Q)	Stepper Motors & Drivers & Controllers
(R)	Graphic/ Logic Panels
(S)	Field Network Devices
(T)	Software