

ROTARY SWITCH

MODEL

SR2512F-0206-(L)K0A-C9-S-3

SPECIFICATIONS

Rating	AC125V 0.3A
Contact Resistance	50 mΩ Max.
Insulation Resistance	DC500V-100 MΩ Min.
Withstand Voltage	AC500V-1 Minute
Rotation Torque	1.0±0.5 Kg-cm
Life cycle	10000 Cycle
Sizes (m.m.)	As Following Drawings

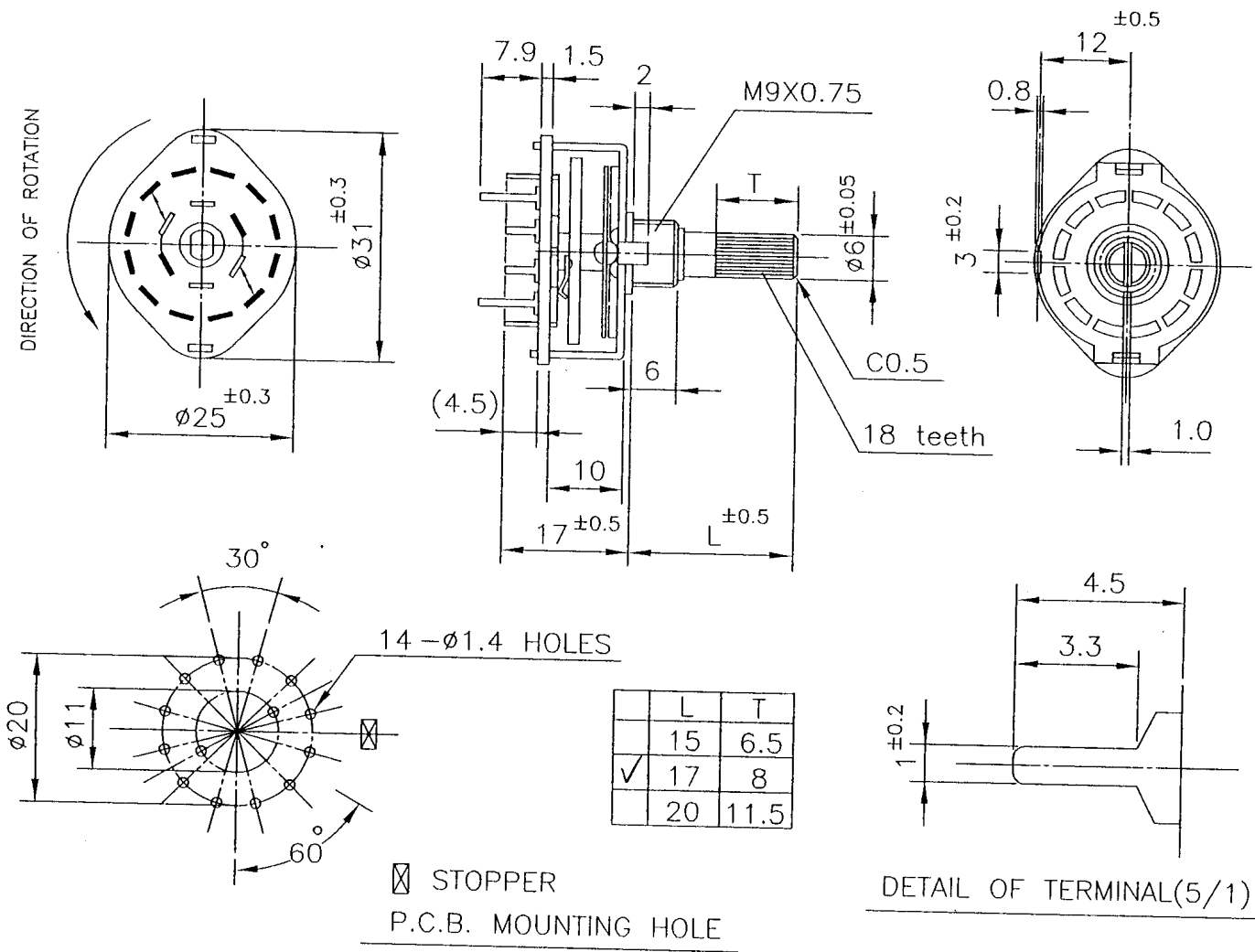

- NOTE:
1. TOLERANCES UNLESS OTHERWISE SPECIFIED: ± 0.4 mm
 2. ACCESSORY PARTS: $\phi 9$ HEXAGON NUT ONE PIECE & WASHER ONE PIECE
 3. TIMING: SHORTING

Date	2006.07.24	DWN	陳 99.7.2 筱婷	CHKD	APP'D	柯 99.7.2 建
------	------------	-----	-------------------	------	-------	------------------

TAIWAN ALPHA ELECTRONIC CO., LTD.

	Specification Rotary switch SR25XXF	DOC. No: Rev. A
		Date:
		Author: 何建志
		Approved: 王茂松

CONTENTS 内容

Section	Description	Page
1.0	Test Conditions	2
2.0	Outside Dimension	2
3.0	Mechanical Performance	2
4.0	Electrical Performance	3
5.0	Endurance Performance	3
6.0	Note	4

	Specification	DOC. No: _____	Rev. A
	Rotary switch	Date: _____	
	SR25XXF	Author: 何建志	
		Approved: 王茂松	

1. TEST CONDITIONS

Standard test conditions shall be 5-35°C in temperature and 45-85% RH in humidity.
Should any doubt arise in judgment test shall be conducted at 20±2°C and 65±5% RH.

2. OUTSIDE DIMENSION

Append drawing.

3. MECHANICAL PERFORMANCE

Item	Test Condition	Specification
3.1 Operating force	Operation temperature:-10°C ~ +70°C Storage temperature:-40°C ~ +85°C	1.0±0.5kgf-cm
3.2 Control strength	A static load of 1000gf-cm shall be applied in the operating direction and tensile direction of the unit for one minute.	N/A
3.3 Terminal strength	A static load of 1000gf-cm shall be applied to the tip of the terminal in a desired direction for one minute. The number of tests shall be one per terminal.	N/A
3.4 Control wobble	Shall be measured by applying a static load of 100gf-cm to the tip of control unit.	Less than 1 mm
3.5 Soldering	Regarding preheating, the entire flow duration should not exceed 2 minutes, and soldering surface temperature (undersurface of PCB) shall be settled within 100°C. Temperature of solder 260±5°C Duration of dipping 4±0.5 seconds	More than 90% of the dipped part shall be covered by solder

	Specification Rotary switch SR25XXF	DOC. No: _____ Rev. A
		Date: _____
		Author: 何建志
		Approved: 王茂松

Item	Test Condition	Requirement
3.6 Soldering heat resistance resistance	Flow soldering condition: to be performed in 4±0.5 seconds within 260±5°C Manual soldering condition: to be performed in 3±0.5 seconds Max within 350±5°C	No abnormalities shall be observed in appearance and operation shall be assured.

3.6 Shaft stopper strength: N/A More than 5kg-cm

3.7 Bushing mount strength N/A 9kgf-cm MIN .

4. ELECTRICAL PERFORMANCE

Item	Test Condition	Requirement
4.1 Rating	N/A	AC125V 0.3A
4.2 Contact resistance	Shall be measured at 1KHz±200Hz (Max 20mV, Max 50mA) or 5V DC, 1A by a voltage drop method	Less than 50mΩ
4.3 Insulation resistance	Shall be measured by applying 500V DC, between all terminals and between the terminal and the frame for 1 minute ± 5 seconds	More than 100MΩ
4.4 Withstand voltage	500V AC (50~60Hz, 2mA) Shall be applied between all terminals and between the terminal and frame for one minute	No function damage or breakdown.

5. DURABILITY

5.1 Operating life under no load	10,000 cycles of operation shall be performed continuously at a rate of 15-20 cycles per minute without load.	Contact resistance: less than 200mΩ Insulation resistance:
----------------------------------	---------------------------------------------------------------------------------------------------------------	------------------------------------------------------------------

	Specification Rotary switch SR25XXF	DOC. No: _____ Rev. A
		Date: _____
		Author: 何建志
		Approved: 王茂松

After operating life test, shall be in accordance with the following specifications.

more than 50MΩ
Withstand Voltage:
250V AC per one minute
Operating force:
less than +10%,-30%
for initial operating force

Item	Test Condition	Requirement
5.2 Operating life under load	10,000 cycles of operation shall be performed continuously at a rate of 15-20 cycles per minute with resistive load of AC125V 0.3A After operating life test , shall be in accordance with the following specifications.	Contact resistance : less than 500mΩ Other specifications are the same as operating life under no load.

6. NOTE

Terminals top side is covered by flux resist resin.