

Company Profile

บริษัทฯ ก่อตั้งขึ้นในปี 2008 มีความเชี่ยวชาญในการจำหน่ายเครื่องจักร และซ่อมบำรุงรักษาอุปกรณ์เครื่องจักรต่างๆ บริษัทฯ มีพื้นที่ 4,000 ตร.ม. และมีคลังสินค้ามากกว่า 7,000 ตร.ม. มีพนักงาน 62 คน รวมถึงวิศวกรหลังการขาย 26 คนพร้อมให้บริการลูกค้ามากกว่า 1,000 รายและกระจายอยู่ทั่ว 77 จังหวัดในประเทศไทย ในประสบการณ์การให้บริการระดับมืออาชีพมายาวนานถึง 12 ปี มีความมุ่งมั่นในการบริการรวดเร็วภายในเวลา 12-24 ชั่วโมง ในเขตกรุงเทพฯ และปริมณฑล เลือกรับเครื่องจักรและการบริการที่ดี เลือก LT GROUP ความต้องการของคุณลูกค้า คือ เป้าหมายของเรา และเป้าหมายของเรา คือ ความเชื่อมั่นของคุณลูกค้า



งานออกบูธจัดแสดงสินค้าที่ อิมแพ็ค เมืองทอง ,ไบเทค บางนา

งานบริการหลังการขาย



OUR PARTNERS



CUSTOMER



PRODUCT



**CJG1000-P Flatbed Laser Pipe Cutting Machine Loading
Semi-automatic Technical Solution Version V1.0**

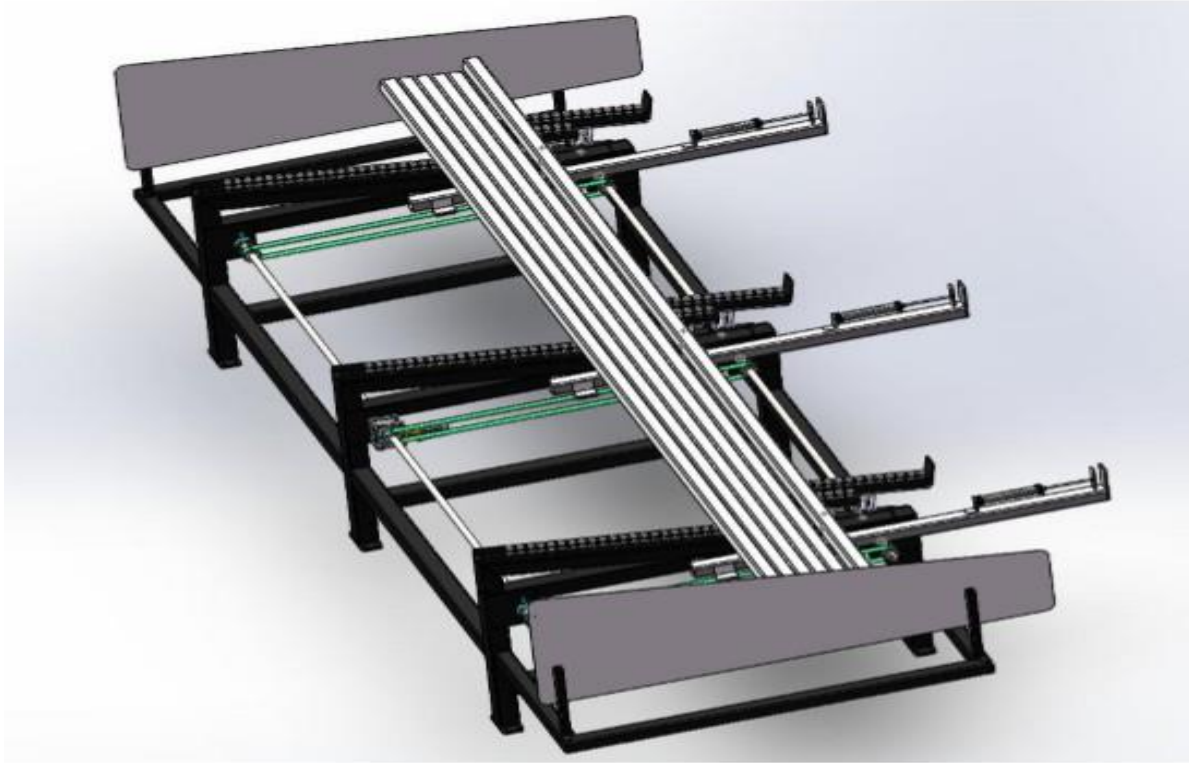

Overall program

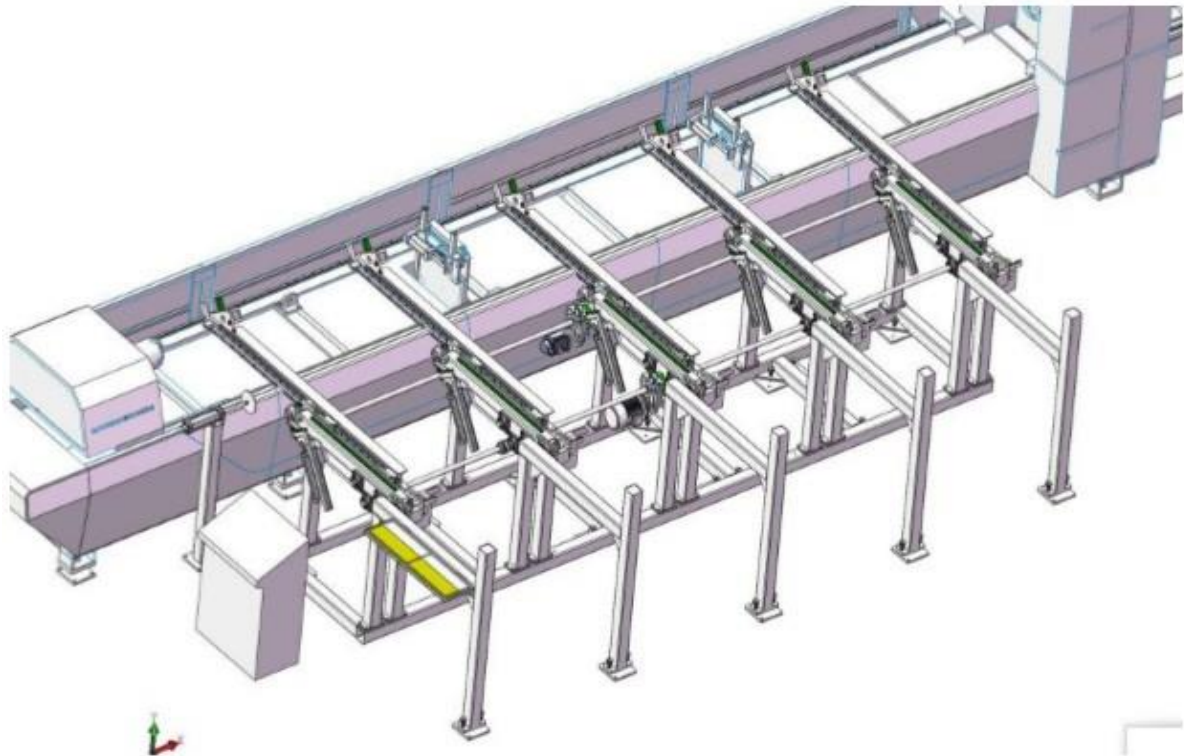

Dimensions

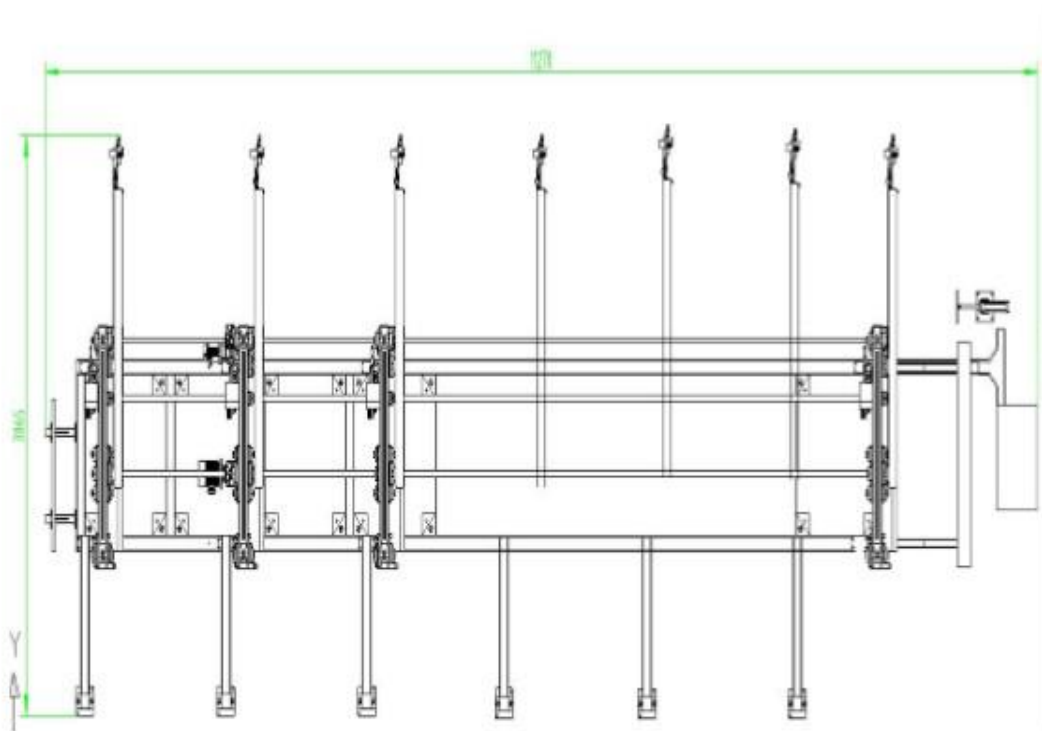

work process

1. Raw material palletizing

The pipes are transported to the pipe material area by driving to ensure that the plates are in the feeding area.

2. Pipe feeding

Manually push the pipe to the belt conveyor, and then drive it to the end through the belt, and the end is checked.

Turn off the trigger to start the ejector cylinder and push the material to the loading cylinder. The positioning cylinder is opened for positioning and positioning

After completion, the feeding device sends the pipe to the pipe cutting machine to be clamped out. When the pipe cutting machine finishes the clamping, the feeding device return.

1. Application range, processing technology

(1) Product design application scope

<ul style="list-style-type: none">• Material Stainless steel pipe, carbon steel pipe, aluminum pipe, etc.
<ul style="list-style-type: none">• Applicable pipe specifications
<ul style="list-style-type: none">• Round tube size 20mm-150mm
<ul style="list-style-type: none">• Tube length 6000mm
<ul style="list-style-type: none">• Material to load 2T
<ul style="list-style-type: none">• Maximum weight of single root 150KG
<ul style="list-style-type: none">• Axial error of clamping and feeding tube +/-3mm

(2) Processing technology

① Adjust the limit baffle → ② Board lifting cylinder to raise → ③ Coding in the material area → ④ Lift cylinder to raise → ⑤ Block

Cylinder descending → ⑥ Clamping cylinder clamping → ⑦ Conveying beam sends the pipe into place → ⑧ Laser cutting machine profiling wheel rises

(3) Matters needing attention

The loading code area is limited to materials of the same model and the same length.

Serial number	Important parts	Parts Brand	manufacturer
1	Variable frequency brake motor		Shanghai Saijing
2	servo motor		Delta
3	Reducer		Shanghai Saijing
4	Bearing		Japan NSK
5	Bearing seat		Misumi
6	Frequency converter		Schneider
7	Controller		Delta
8	Cable		Shanghai Qifan
9	Pneumatic Components		AirTAC

Equipment operation training

- 1. Party B shall complete the training of relevant technical personnel of Party A after the commissioning is completed.**
- 2. Party A can arrange suitable personnel, such as electrical engineers and mechanical engineers, to assist Party B in debugging and accept training**

Training.

- 3. Party B shall provide instructions, wiring diagrams, operation manuals, technical guides, etc. of the equipment, electrical system hardware and other related equipment.**
- 4. Party B provides system maintenance manuals, etc.**

After-sales service and quality assurance

(1) A solemn commitment and strict system (see the ISO9001 quality assurance system for after-sales service regulations).

- 1. Subject to the time the equipment is put into operation, within one year, a package repair will be implemented, and the machine will be guaranteed to receive a call or fax**

Reply within 24 hours.

- 2. The maintenance service personnel must make a detailed record of the completed maintenance tasks and the methods to solve the problems when they provide services to the user.**

Records, and users feedback their opinions to the unit, and implement strict assessment and control on the quality of service personnel.

(2) A full-time machine-electric-hydraulic integrated service team ensures the operability of the service network.

(3) Sufficient spare parts are available to ensure normal use by users.

Since our company's products have entered the mass production stage, a strong foundation has been established for the provision of spare parts.

Ensure the supply of spare parts within one operating cycle.



Contacts



LT INDUSTRIAL GROUP CO.,LTD.

จำหน่ายโดย : บริษัท แอลที อินดัสเทรียล กรุ๊ป จำกัด

Call: (+66) 093-7262495 (HOTLINE)

Call: (+66) 099-1283030 (HOTLINE)

Web: WWW.LTINDUSTRIALGROUP.COM

E-mail : LTINDUSTRIALGROUP.COM



Line ID: [@LTINDUSTRIALGROUP](https://www.line.me/@LTINDUSTRIALGROUP)