

# Electrical System

Edition 1

---

**MEMO**

---

# Table of Contents

## Electrical System

Safety Precautions .....	7
Applicable Models .....	7
Introduction .....	9
Electrical Supply System .....	10
Engine Starting Circuit .....	12
Start Operation .....	12
After Start .....	14
Engine Preheating System .....	16
Engine Stop .....	17
Charging System .....	18
Monitoring System .....	19
Instrument Panel .....	20
Monitoring System Schematic .....	22
Operation .....	24
Instruments .....	24
Warning and Indicator Lights .....	26
Indication of Warning Lights .....	26
Indication of Multifunction Gauge and Letter Information Area .....	27
Initial Operation .....	28
Mode Selector Switch .....	29
Graphic Information Area Display .....	30
Overview .....	30
Main Menus for the Graphic Display Area .....	31
Menu Selector Buttons .....	31
Main Menu .....	32
Language .....	32
Set Clock .....	33
Filter/Oil Info .....	33
Adjust Display .....	34

Set Password .....	35
Special Menu .....	36
Entering/Accessing and Exiting/Escaping Menus .....	36
Special Menu Selections .....	37
Electronic Hydraulic Control System (e-EPOS) ..	50
Control System Schematic .....	50
Power Mode Control .....	52
Operation .....	54
Power Mode Control - Circuit Diagram .....	56
Work Mode Control .....	57
Work Mode Control - Circuit Diagram .....	58
Engine Control System .....	59
Engine Control Dial .....	60
Engine Control Motor .....	61
Engine Control Circuit Diagram .....	62
Automatic Deceleration Control (Auto Idle Control)	
63	
Engine Overheat Protection System .....	64
Power Boost Mode .....	65
Operation .....	65
Power Boost Control - Circuit Diagram .....	66
Automatic Travel Speed Control .....	67
Automatic Travel Speed Control - Circuit Diagram .....	68
Adjust Engine Speed .....	72
Engine Throttle controller .....	73
Self-diagnostic Function .....	74
e-EPOS Controller .....	74
Air Conditioner System .....	75
Outline .....	75
Internal and External Filters .....	76
Air-Conditioning System Layout .....	78

Air Conditioner/heater Circuit Diagram.....	79
Air Conditioner/heater Unit .....	80
Ambient Air Temperature Sensor.....	85
Sun Sensor.....	86
Control Panel.....	86
Compressor .....	94
Receiver Dryer .....	94
<b>Wiper System .....</b>	<b>95</b>
Wiper Circuit.....	95
Wiper operation .....	96
<b>Lighting System .....</b>	<b>98</b>
Lighting System Circuit Diagram .....	98
Kind of Light .....	99
Operation.....	99
<b>Overload Warning Device.....</b>	<b>100</b>
Overload Warning Device Circuit Diagram.....	100
<b>Audio Controller .....</b>	<b>101</b>
Audio Controller Circuit Diagram.....	101

---

**MEMO**

---

# SAFETY PRECAUTIONS

---



## CAUTION!

---

Follow all safety recommendations and safe shop practices outlined in the front of this manual or those contained within this section.

Always use tools and equipment that are in good working order.

Use lifting and hoisting equipment capable of safely handling load.

Remember, that ultimately safety is your own personal responsibility.

---

## APPLICABLE MODELS

The contents of this section apply to the following models and serial number ranges.

MODEL	SERIAL NUMBER RANGE
DX225LCA	5167 and Up



# INTRODUCTION

The electrical system for this equipment is DC 24 volts. The rated voltage for all electric components is 24 volts with the exception of the stereo and the air-conditioning control actuator. The system contains two 12 volt batteries connected in series and a three phase AC generator with a rectifier. The electric wiring used in the system is easily identifiable by the insulator color. The color symbols used in the electrical system are listed in the following chart.

## Electric Wire Color

Symbol	Color
W	White
G	Green
Or	Orange
B	Black
L	Blue
Lg	Light green
R	Red
Gr	Gray
P	Pink
Y	Yellow
Br	Brown
V	Violet

**NOTE:** *RW: Red wire with White stripe  
R - Base Color, W - Stripe Color*

**NOTE:** *0.85G: Nominal sectional area of wire core less insulator = 0.85 mm<sup>2</sup>*

# ELECTRICAL SUPPLY SYSTEM

The electric power circuit supplies electric current to each electric component. It consists of a battery, battery relay, starter switch, circuit breaker, fusible link and fuse box.

The negative terminal of the battery is grounded to the vehicle body.

Even when the starter switch (5) is in the "OFF" position, electric current is supplied to the following components through battery (1) → fusible link (3) → fuse box (6).

1. Terminal "1" of DC-DC converter (for memory backup of stereo)
2. Terminal "B" of starter switch
3. Hour meter
4. Engine controller
5. Fuel feeder pump switch
6. Terminal "6" of wiper motor
7. Terminal "13" of wiper controller
8. Terminal "CN6-11" of instrument panel
9. Terminal "CN9-6" of air conditioner panel
10. Cabin light

When the starter switch (5) is in the "ON or START" positions, the current flows from the battery (1) → fusible link (3) → fuse box (6) → "B" terminal of starter switch (5) → "BR" terminal of starter switch (5) → "BR" terminal of battery relay (2) which activates the coil of the battery relay and the electric supply system is energized.

When the battery relay's contacts are connected, all electric devices can be operated.

While the engine is not running, the electric power for all electric devices are supplied by the battery. Once the engine is started the power is supplied from the alternator (7).

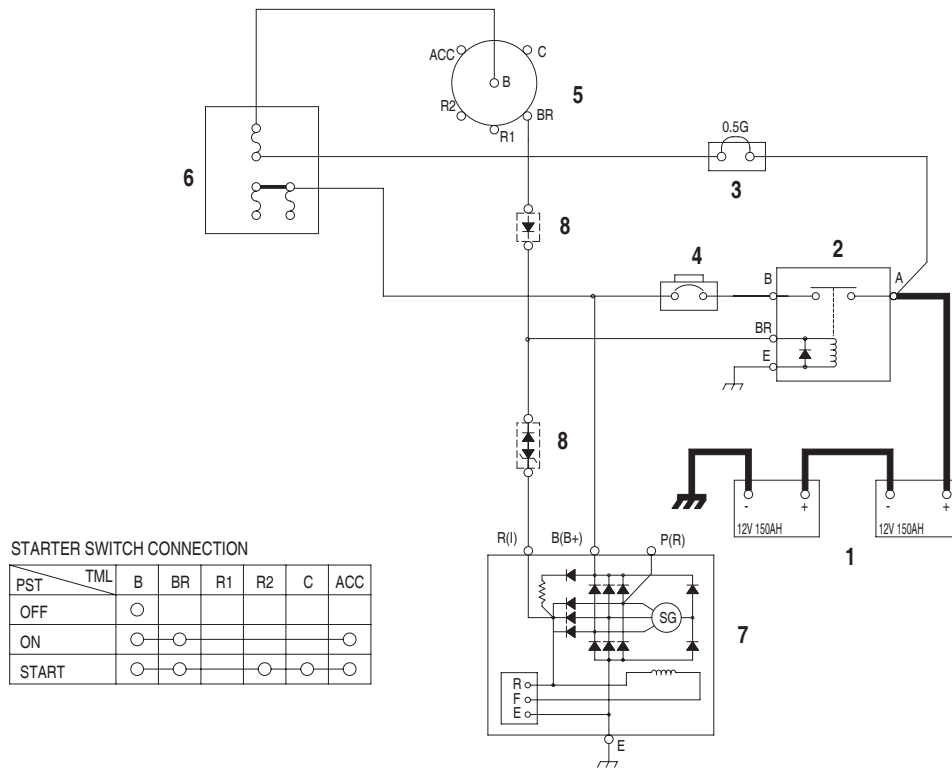

FG001476

**Figure 1** ELECTRIC POWER CIRCUIT DIAGRAM

Reference Number	Description
1	Battery
2	Battery Relay
3	Fusible Link
4	Circuit Breaker

Reference Number	Description
5	Starter Switch
6	Fuse Box
7	Alternator
8	Diode

# ENGINE STARTING CIRCUIT

## Start Operation

When the starter switch is turned to the "START" position, the "S" and "E" terminals of the starter controller (7) are connected. At this time the contacts in the starter relay (8) are closed by the current flow from the battery (1) → fusible link (3) → fuse box (6) → "B" terminal of starter switch (5) → "C" terminal of starter switch (5) → "30" terminal of starter relay (12) - "87a" terminal → "C" terminal of starter relay (8) - "D" terminal → "S" terminal of starter controller (7) - "E" terminal → ground.

When the contact point "B" and "PP" of starter relay (8) are connected, the pinion gear of the starter (9) is pushed forward and makes contact with the ring gear of the flywheel and the internal contacts of the starter are connected. The current flows from the battery (1) → "A" terminal of the battery relay (2) → "B" terminal of the battery relay (2, Figure 3) → "B" terminal of the starter (9). The starter motor is rotated and the engine is started.

If the instrument panel has the password function activated , input number should match the set number, otherwise the start circuit closes and the engine does not start.

**NOTE:** *If the security system is "LOCKED," a four-digit password will be required to start the engine. If the system is "UNLOCKED," no password will be required and this display screen will not appear.*

*In the event the security system is locked, current flows from battery (1) → fusible link (3) → fuse box (6) → "B" terminal of starter switch (5) → "ACC" terminal of starter switch (5) → "86" terminal of starter relay (12) → "85" terminal of starter relay (12) → "CN1-15" terminal of e-EPOS (13) → ground. This current flow causes the coil in starter relay (12) to be activated, opening contacts at "87a" terminal. This prevents starter relay (8) from functioning.*

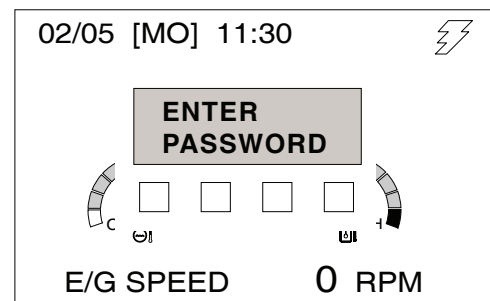

FG001445

Figure 2

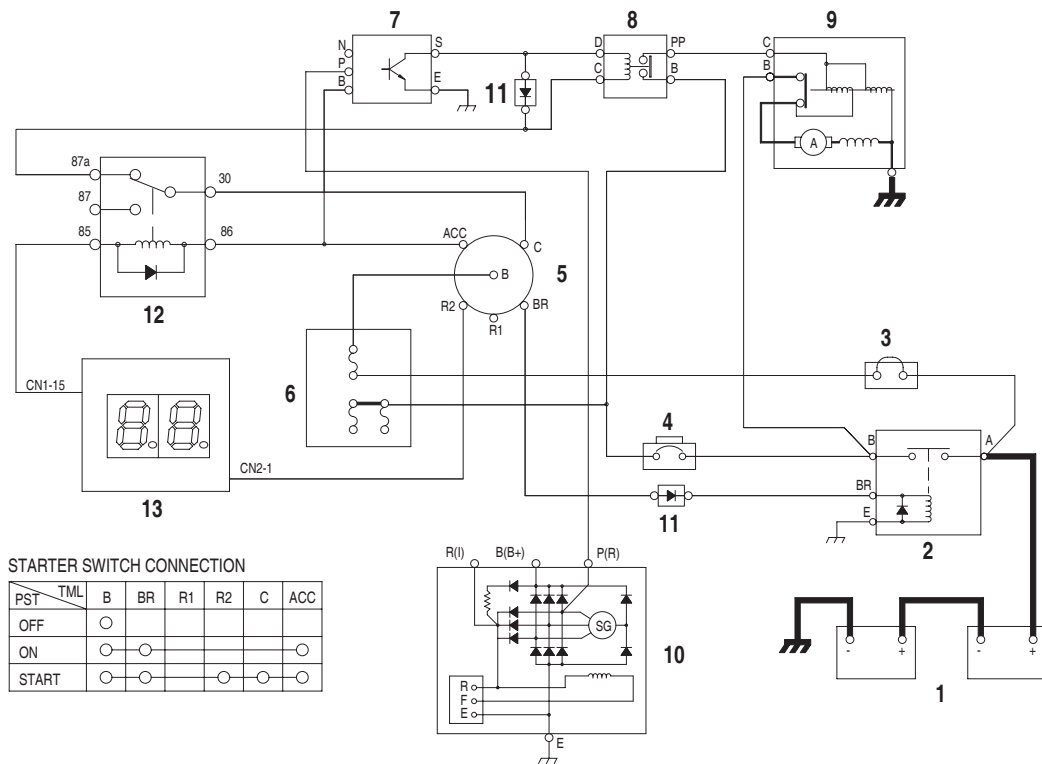

FG003926

**Figure 3** STARTER CIRCUIT (1) - WHILE STARTING

Reference Number	Description
1	Battery
2	Battery Relay
3	Fusible Link
4	Circuit Breaker
5	Starter Switch
6	Fuse Box
7	Starter Controller

Reference Number	Description
8	Starter Relay
9	Starter
10	Alternator
11	Diode
12	Starter Relay 2
13	e-EPOS Controller

## After Start

Once the engine has been started, the belt driven alternator (10) generates a current.

The output generated by the alternator (10) is a square wave pulse voltage through the "P" terminal and the frequency of the pulse voltage is proportional to the rotation of the alternator.

The starter controller (7) monitors the frequency of the output current. Once the frequency is equivalent to 500 rpm, it is sensed and the connection between "S" and "E" terminals and the connection between "B" and "PP" terminals are opened. As a result the rotation of the starter (9) is stopped. Once the engine is running, the starter (9) will not operate even if the starter switch (5) is moved to the start position, preventing possible damage to the starter.



# ENGINE PREHEATING SYSTEM

An air heater (8) is installed in the intake manifold of the engine. When the starter switch (5) is turned to "PREHEAT" the current flows from the battery (1) → fusible link (3) → "B" terminal of starter switch (5) → "R1" terminal of starter switch (5) → "C" terminal of preheat relay (7) → ground. This current flow causes the coil in the preheat relay (7) to be activated, closing contact.

When the contacts of the preheat relay (7) are closed, the heating coils of the air heating device are heated by current flowing from the battery (1) → battery relay (2) → preheat relay (7) → air heater (8) → ground.

The duration of the heating time is approximately 20 seconds. After 20 seconds later to start preheating, the preheat indicator light will be turned "OFF" by the timer in the e-EPOS controller.

If the starter switch (5) turns to "START", the heating process will go on because the current flows into the coil in preheat relay (7) through "R2" terminal of starter switch (5).

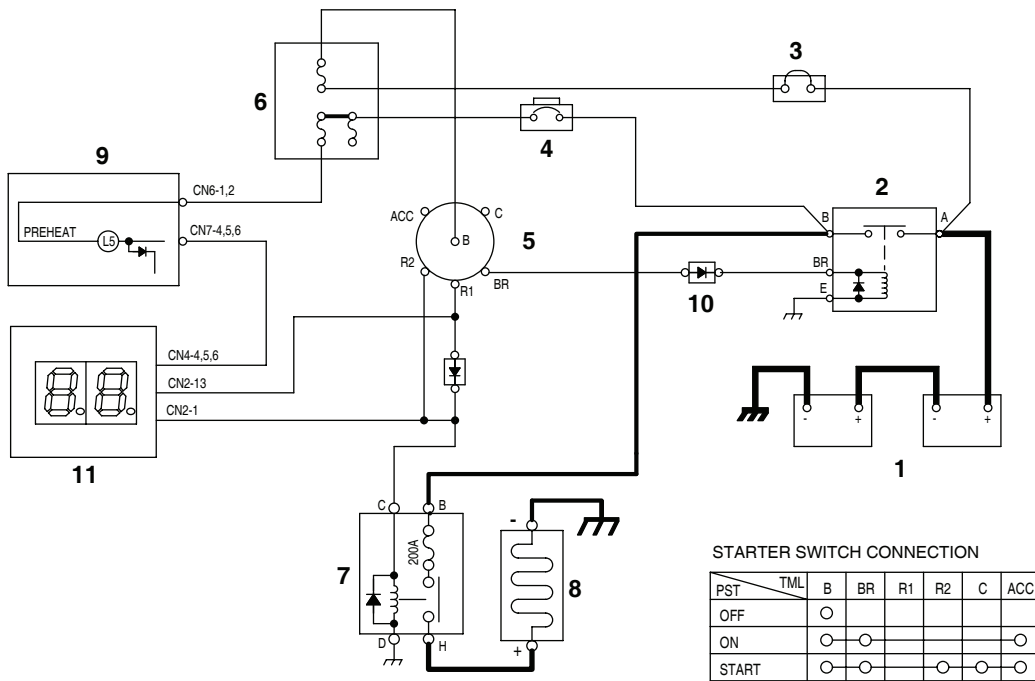

FG002088

Figure 5 ENGINE PREHEAT CIRCUIT

Reference Number	Description
1	Battery
2	Battery Relay
3	Fusible Link
4	Circuit Breaker
5	Starter Switch
6	Fuse Box

Reference Number	Description
7	Preheat Relay
8	Air Heater
9	Preheat Indicator Light
10	Diode
11	e-EPOS Controller

# ENGINE STOP

Engine Stop circuit consists of starter switch (5), engine stop motor (9), engine stop relay (8). The current flowing into the "ACC" terminal of starter switch allows the engine's start and stop function.

The stop Motor is decelerated by the worm gear by itself and converts the rotary motion into a back-and-forth motion to pull and push the engine stop lever.

If the starter switch turns "ON", the motor will stop automatically after revolving  $0^\circ \rightarrow 180^\circ$ , and if the starter switch turns "OFF", the motor will stop at the engine stop position by revolving  $180^\circ \rightarrow 360^\circ$

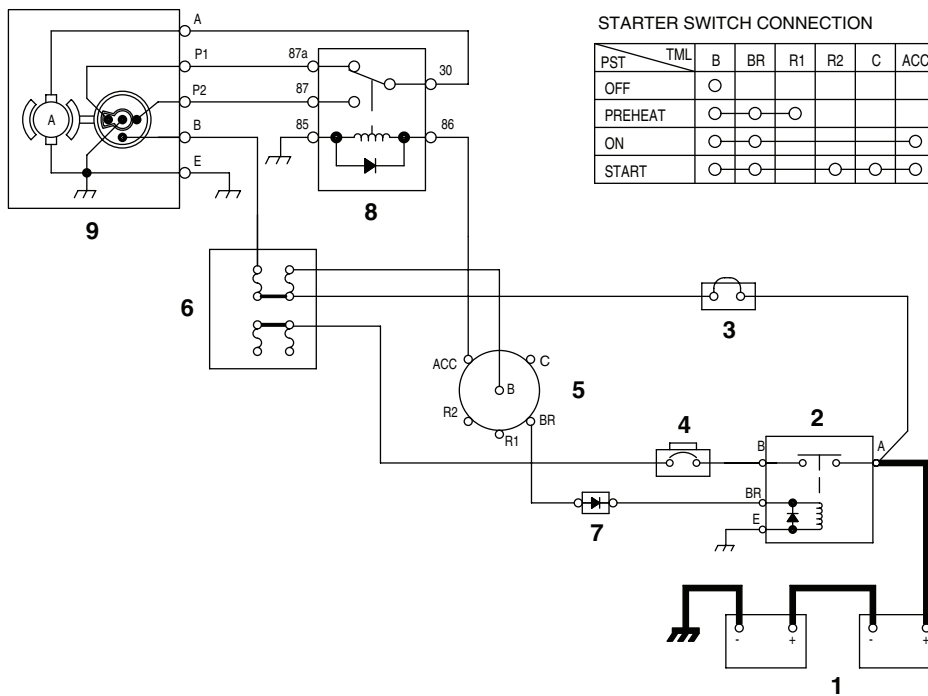

FG002089

Figure 6 ENGINE STOP CIRCUIT

Reference Number	Description
1	Battery
2	Battery Relay
3	Fusible Link
4	Circuit Breaker
5	Starter Switch

Reference Number	Description
6	Fuse Box
7	Diode
8	Injector Solenoid
9	Engine Stop Motor

# CHARGING SYSTEM

When the starter switch (5) is turned to the "ON" position, an initial excited current flows to the field coil of the alternator (7) through the battery relay (2) and circuit breaker (4). When the engine is started from this condition the alternator (7) starts charging. The current flows from the "B(B+)" terminal of alternator (7) → circuit breaker (4) → battery relay (2) → battery (1).

The alternator also supplies electric current to other electrical components. When the alternator (7) starts to operate, a current flows from the "R(I)" terminal of alternator → diode (8) → battery relay (2) coil securing a path for the charging current to the battery (1). Thus preventing the possibility of a high voltage build up and possible damage to the electric system.

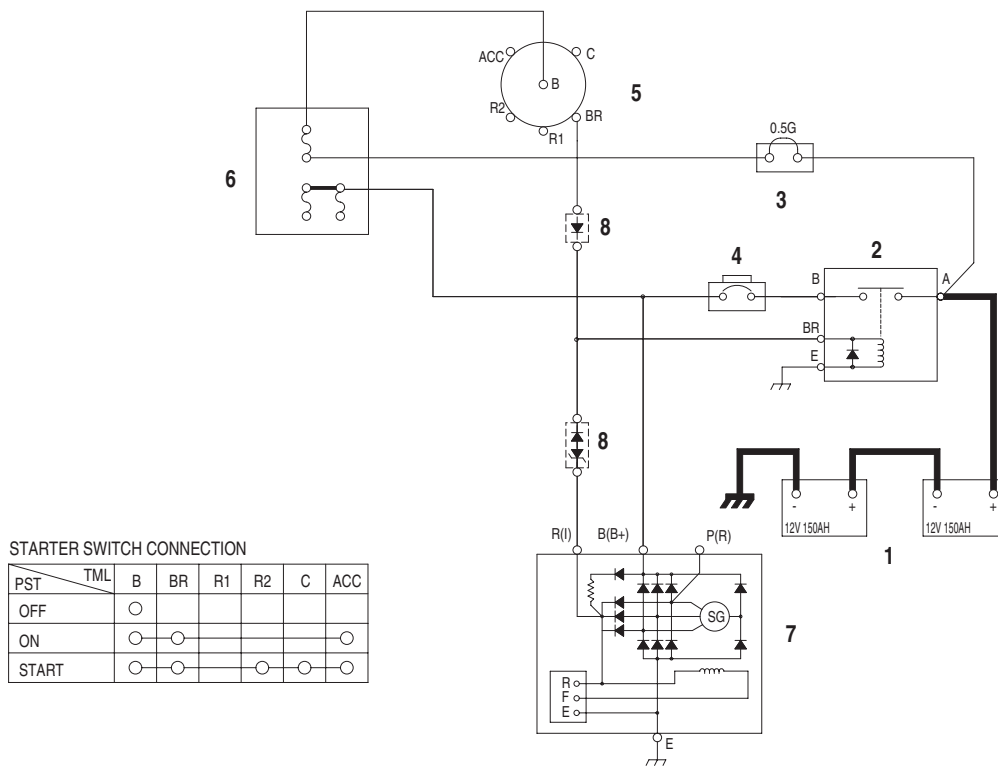

FG001474

Figure 7 CHARGING CIRCUIT

Reference Number	Description
1	Battery
2	Battery Relay
3	Fusible Link
4	Circuit Breaker

Reference Number	Description
5	Starter Switch
6	Fuse Box
7	Alternator
8	Diode

# MONITORING SYSTEM

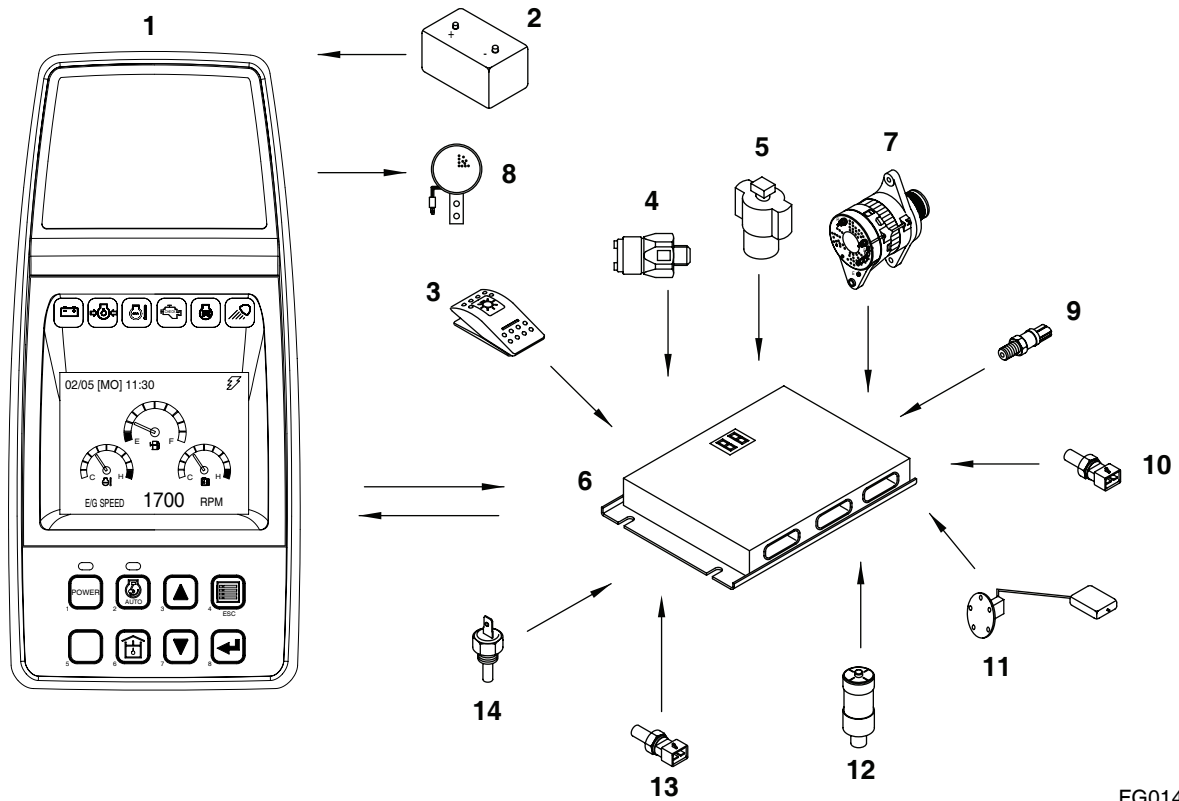

FG014297

Figure 8

Reference Number	Description
1	Instrument Panel
2	Battery
3	Light Switch
4	Return Filter Switch
5	Pilot Filter Switch
6	e-EPOS Controller
7	Alternator

Reference Number	Description
8	Warning Buzzer
9	Pump Discharge Pressure Sensor
10	Hydraulic Oil Temperature Sensor
11	Fuel Sensor
12	Air Cleaner Indicator
13	Engine Coolant Temperature Sensor
14	Engine Oil Pressure Switch

The monitoring system displays the various data and warning signals onto the instrument panel by processing the information gathered from the e-EPOS controller. It displays information selected by the operator.

# Instrument Panel

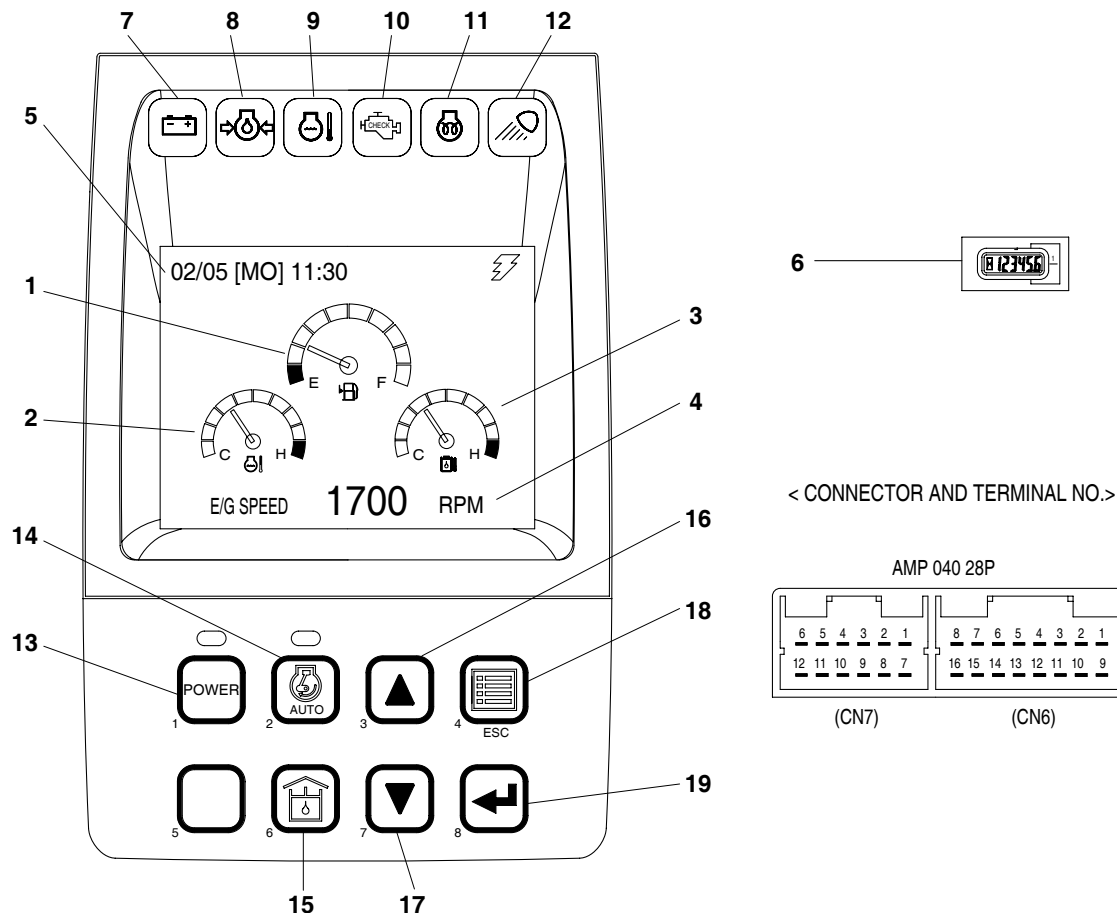

Figure 9

FG014290

Gauges	Warning Lights	Mode Selector Switches
1. Fuel Gauge	7. Charge Warning Light	13. Power Mode Selector Switch and Indicator
2. Engine Coolant Temperature Gauge	8. Engine Oil Pressure Warning Light	14. Auto Idle Switch and Indicator
3. Hydraulic Oil Temperature Gauge	9. Coolant Temperature Warning Light	15. Flow Adjusting Switch
4. Multifunction Gauge and Letter Information Area	10. Engine Check Warning Light	16. Up Button Switch
5. Digital Clock	11. Preheat Indicator Light	17. Down Button Switch
6. Hour Meter	12. Work Light Indicator Light	18. Display Selector Switch
		19. Selector Button Switch

When the engine starter switch is turned to the "I" (ON) position, all gauge bands, switch/button indicator lights and indicator/warning lights will turn "ON" and the alarm buzzer will sound about two seconds.

During this functional check, a LOGO will appear on the multi function gauge in the graphic information area



# Monitoring System Schematic

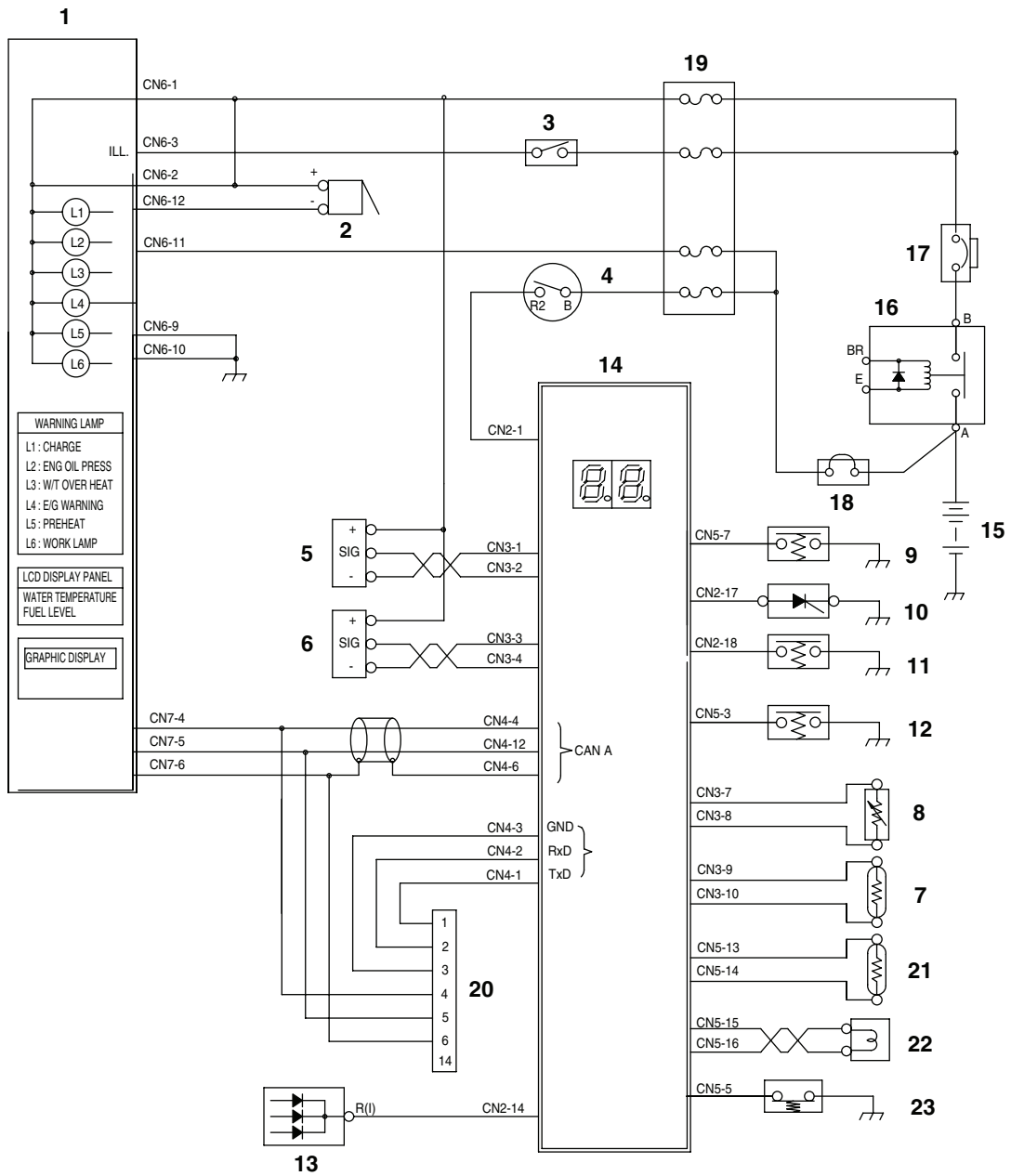

Figure 10

FG002093

Reference Number	Description
1	Instrument Panel
2	Pilot Buzzer
3	Light Switch
4	Starter Switch
5	Front Pump Pressure Sensor
6	Rear Pump Pressure Sensor
7	Hydraulic Oil Temperature Sensor
8	Fuel Sensor
9	Pedal Pressure Switch (Optional)
10	Air Cleaner Indicator
11	Pilot Filter Switch

Reference Number	Description
12	Return Filter Switch
13	Alternator
14	e-EPOS Controller
15	Battery
16	Battery Relay
17	Circuit Breaker
18	Fusible Link
19	Fuse Box
20	Check Connector
21	Coolant Temperature Sensor
22	Engine Speed Sensor
23	Engine Oil Pressure Switch

# OPERATION





## Instruments

Function	Display	Sensor Specification	
		Input Terminal	Input Specification
Coolant Temperature		ECU-CAN Communication	41°C (106°F) → 1,372 ohms 61°C (142°F) → 855 ohms 102°C (216°F) → 160 ohms 105°C (221°F) → 147 ohms 107°C (225°F) → 128 ohms (When reading increase)
Fuel Level		CN3-7 CN3-8	1/10 LCD (Red Zone) Blinking → over 5K ohms FULL → under 525 ohms
Hydraulic Oil Temperature		CN3-9 CN3-10	40°C (104°F) → 1,397 ohms 50°C (122°F) → 1,139 ohms 60°C (140°F) → 881 ohms 94°C (201°F) → 190 ohms 96°C (205°F) → 177 ohms (When reading increase)
Flow Adjusting		(Output Terminal) CN1-19 CN1-20	48 l/min → 615 mA 70 l/min → 583 mA 90 l/min → 555 mA 130 l/min → 495 mA (Default Set) 210 l/min → 376 mA 244 l/min → 260 mA

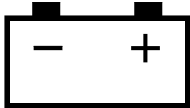

Function	Display	Sensor Specification	
		Input Terminal	Input Specification
Tachometer	<b>E/G SPEED 1750 RPM</b>  FG013531	ECU-CAN Communication	$N = 129 f / 60$ N = Engine speed (rpm) f = Frequency of engine speed sensor (Hz)
Voltmeter	<b>BATTERY 28.0 VOLT</b>  FG000050	CN2-14	0 - 32 VDC
Main pump discharge pressure (front pump)	<b>FRONT PUMP 320 BAR</b>  FG000051	CN3-1 CN3-2	$V = 0.00816 \times P + 1.0$ V: Sensor output voltage (V) P: Displayed pressure (Bar)
Main pump discharge pressure (rear pump)	<b>REAR PUMP 313 BAR</b>  FG000052	CN3-3 CN3-4	



# WARNING AND INDICATOR LIGHTS

## Indication of Warning Lights

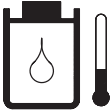
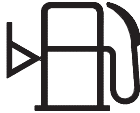
Description	Symbol	Input Terminal	Operation	Remarks
Charge	 <small>HAOA610L</small>	CN2 - 14 CN1 - 8 (9)	It lights in case of no charge [voltage of "R(l)" terminal is below $12 \pm 1V$ ] or overcharge [voltage of "R(l)" terminal is above 33(V)].	Normally, it lights when starting engine and is out after engine starts.
Engine Oil Pressure	 <small>HAOA620L</small>	CN5 - 5 CN1 - 8 (9)	It lights when engine oil pressure is below the reference.	After starting engine, if engine oil pressure is insufficient after 8 seconds, a warning buzzer will sound.
Coolant Temperature	 <small>HAOD350L</small>	CN5 - 13 CN5 - 14	It lights when engine coolant temperature sensor resistant is below about 128 ohms.	
Preheating	 <small>HAOA639L</small>	CN2 - 13 CN1 - 8 (9)	It lights during preheating and turns "OFF" after completion of preheating.  (After 20 sec preheating)	
Work Light	 <small>HB4O2003</small>	CN2 - 6 CN1 - 8 (9)	It lights when work light turns "ON" (24V applied).	

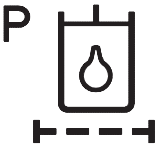
## Indication of Multifunction Gauge and Letter Information Area

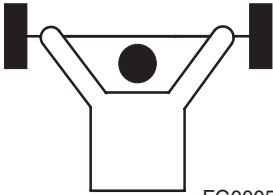
Description	Symbol	Input Terminal	Operation	Remarks
Hydraulic Oil Temperature	 <small>FG000056</small>	CN3 - 9 CN3 - 10	When hydraulic oil temperature is above about 96°C.	
Fuel Exhausted	 <small>FG000057</small>	CN3 - 7 CN3 - 8	When fuel is almost exhausted.	
Air Cleaner	 <small>FG000053</small>	CN2 - 17 CN1 - 8 (9)	When air cleaner is clogged.	
Return Filter	 <small>FG000054</small>	CN5 - 3 CN1 - 8 (9)	When return filter pressure is above about 1.50 kg/cm <sup>2</sup> (21 psi)	
Pilot Filter	 <small>FG000055</small>	CN2 - 18 CN1 - 8 (9)	When pilot filter pressure is above about 1 kg/cm <sup>2</sup> (14 psi)	

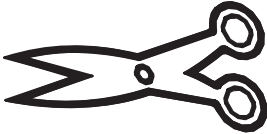
Boost	 FG000554	CN2 - 2 CN1 - 8 (9)	It lights when boost is selected.	
Breaker	 FG001470	CN2 - 10 CN1 - 8 (9)	It lights when breaker is selected.	
Shear	 FG001471	CN2 - 9 CN1 - 8 (9)	It lights when shear is selected.	

## INITIAL OPERATION

Item	Input (Terminal)	Output (Operation and initial setting mode)
Initial Operation	When "CN6-1,2" is applied battery voltage (starter switch shifts from "OFF" to "ON")	<ul style="list-style-type: none"> <li>LCD, all of LED and warning lights are turned "ON" and turned "OFF" after about 2 seconds.</li> <li>Warning buzzer is activated and turned "OFF" after about 2 seconds.</li> <li>Power mode: Standard mode.</li> <li>Work Mode: Digging mode.</li> <li>Auto Idle: High Output (Activation).</li> <li>Display: Indicating coolant temperature, Fuel level, Hydraulic oil temperature, Engine speed.</li> <li>Clock: Current time display.</li> </ul>

**NOTE:** Refer to method for setting clock in operation manual for setting time.

# MODE SELECTOR SWITCH

## Power Mode Switch

Operation Mode		Output Check (Operation mode display LED)	e-EPOS Output		
			Electromagnetic Proportional Pressure Reducing Valve (E.P.P.R Valve) Current (mA)	Swing Priority Solenoid Valve	7-Segment Display
Power Mode	Power Mode	ON	No-load: 200 ±20mA Load: Variable output (Max. current: 600 ±20mA)	-	9 x
	Standard Mode	OFF	No-load: 300 ±20mA Load: Variable output (Max. current: 600 ±60mA)	-	7 x

**NOTE:** When the engine speed is below 1,000 rpm, the output current of E.P.P.R valve is fixed to be 600 ±60mA.

## Auto Idle Switch

Operation Mode		Output Check (Operation mode display LED)
Auto Idle	Activation	ON
	Cancellation	OFF

# GRAPHIC INFORMATION AREA DISPLAY

## Overview

Many kinds of condition of machine are displayed on the letter information display department. The information display department is divided into two menus. One is main menu for user and the other is special menu for specialist. These menus can be moved from normal display mode by the combination of selector buttons.

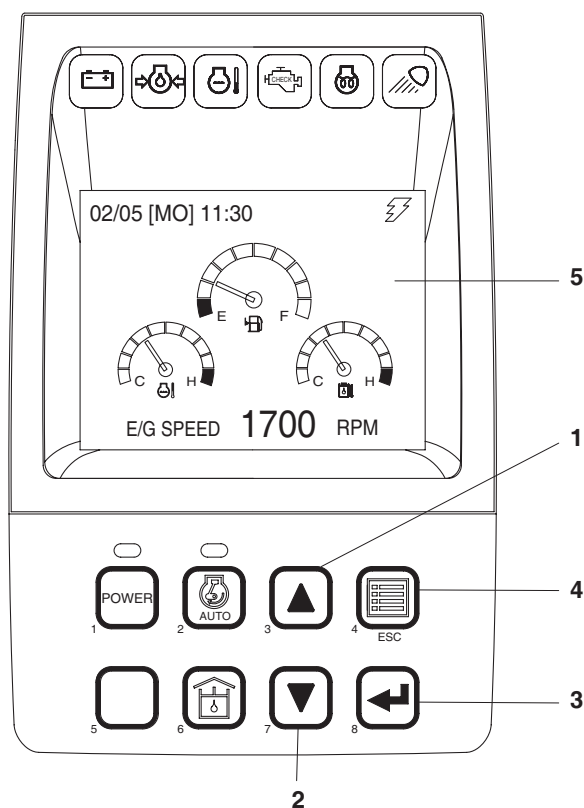

Figure 11

FG014291

Selector Buttons	Graphic Display Area
1. Up Arrow Button	5. Letter Information Display Department
2. Down Arrow Button	
3. Enter Button	
4. Escape Button	

## Main Menu for the Graphic Display Area

1. Main menu: Language setting, Time setting, Filter/Oil information, Brightness adjustment, Password
2. Special menu: Information of machine status, failure information, Information of machine operation.

## Menu Selector Buttons

1. Up Arrow Button (▲, 1 on Figure 11): Move the cursor to up, left and previous screen.
2. Down Arrow Button (▼, 2 on Figure 11): Move the cursor to down, right and next screen.
3. Enter Button (↵, 3 on Figure 11): Move the menu to selected mode. When setting the menu, this button is used to function as the selector button.
4. Escape Button (ESC, 4 on Figure 11): Move a screen to previous menu or main menu.

# MAIN MENU

When the "ESC" button is pressed for more than 3 seconds, the main menu screen is displayed.

Main menu offers sub-menus (language setting, time setting, or filter/oil information, brightness adjustment, password) to the operator.

Refer to the "Operation and Maintenance Manual" for details.

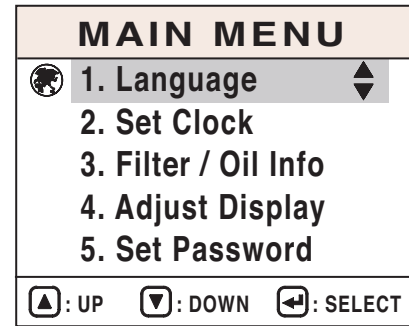

FG000072

Figure 12

## Language

Put the cursor on Language in the main menu and put the Enter Button (↵, 3 on Figure 11) and the language select view appears.

The default language is Korean, but it will memorize and use the newly set language.

Use the Up Arrow Button (▲, 1 on Figure 11) or Down Arrow Button (▼, 2 on Figure 11) to move cursor to a language to be selected on the Language Select display and press the Enter Button (↵, 3 on Figure 11) and the selected language is indicated in the right bottom of the screen.

At this point pressing the Enter Button (↵, 3 on Figure 11) or the Escape Button (ESC, 4 on Figure 11) more than 1 second brings the main menu with changed language and then pressing the ESC button again shows the default view.

Without pressing a button more than 20 seconds, the default view appears.

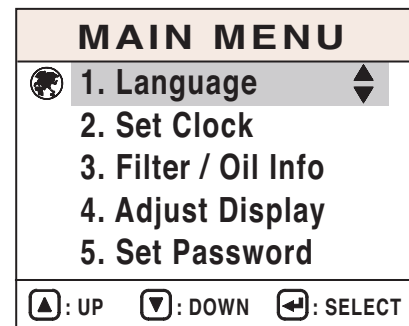

FG000072

Figure 13

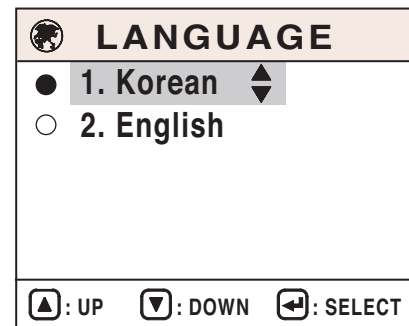

FG000783

Figure 14

## Set Clock

It is used to adjust time of the digital clock.

Pressing the Enter Button (↵, 3 on Figure 11) in the Main Menu after putting cursor on Set Clock brings Set Clock display.

Without pressing a button more than 20 seconds, the default view appears.

Please refer to the Operation Manual for detailed information on Time Setting.

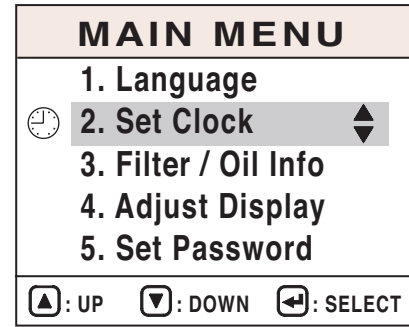

FG000075

Figure 15

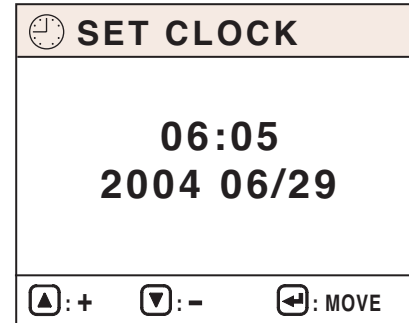

FG000076

Figure 16

## Filter/Oil Info

This mode displays total operating hours of filters and oils.

After changing the filter and oil, reset the operating hour and then the operating hours until the next service interval can be easily checked.

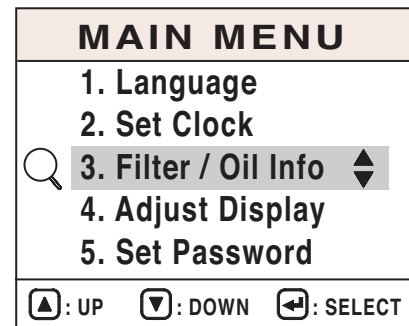

FG000077

Figure 17

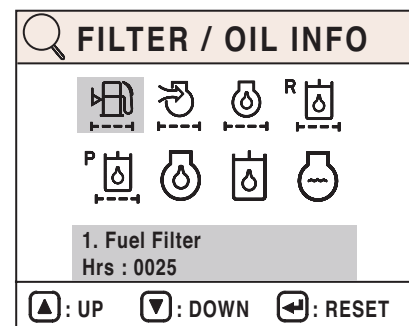

FG000078

Figure 18

## Menu Display Order and Icon Explanation

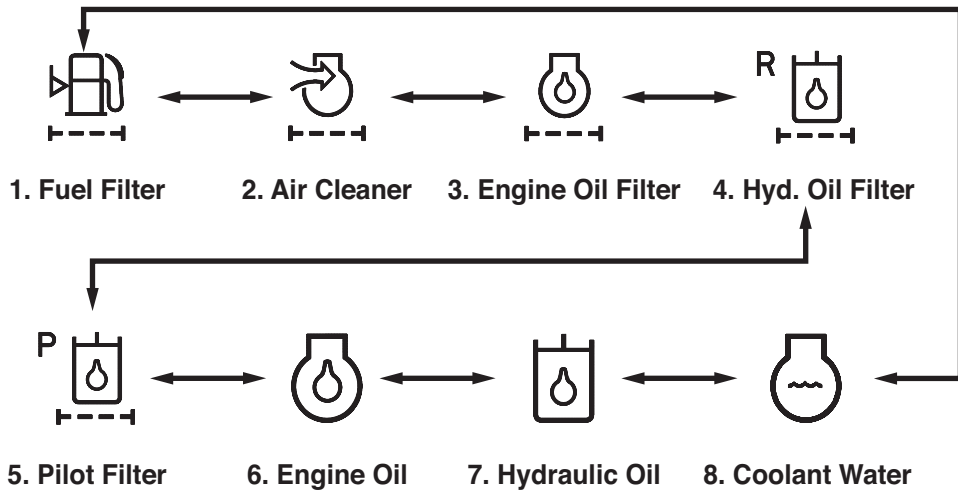

FG001358

Figure 19

## Adjust Display

Pressing the Enter Button (↵, 3 on Figure 11) in the main menu after putting cursor on Adjust Display brings Adjust Display.

Screen brightness can be adjusted using the Up Arrow Button (▲, 1 on Figure 11) or the Down Arrow Button (▼, 2 on Figure 11).

The default brightness is set to 50%.

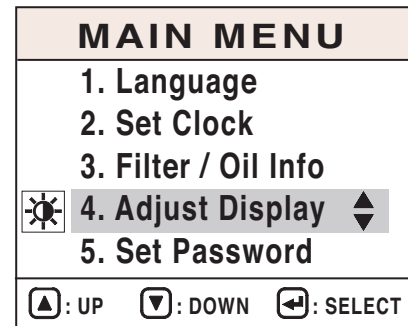

FG000080

Figure 20

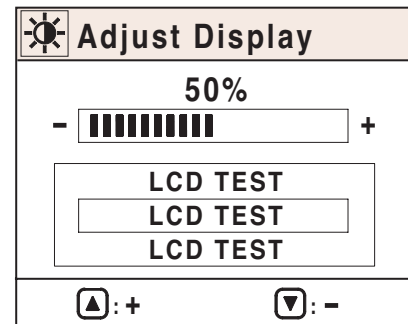

FG000081

Figure 21

## Set Password

This menu is used to apply (lock), release, or change password.

Please refer to the Operation Manual for detailed information on Password Setting.

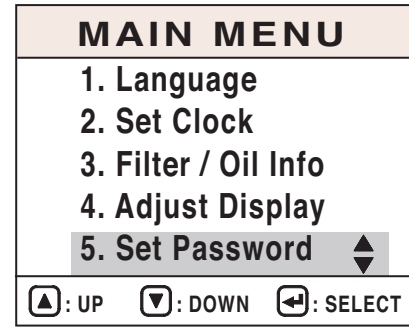

FG000227

Figure 22

# SPECIAL MENU

In this menu, many types of operating conditions and functions can be accessed and displayed, including the e-EPOS controller. This menu is mainly used for machine testing and failure diagnostics.

The special menu offers three sub-menus:

1. Machine status.
2. Failure information.
3. Information on machine operation.

## Entering/Accessing and Exiting/Escaping Menus

### Entering/Accessing Menus

When normal mode screen is displayed, if the enter button (↵, 4) and escape button (ESC, 3) are pressed simultaneously for more than 3 seconds, normal mode screen (Figure 24) will be changed to special menu screen (Figure 25).

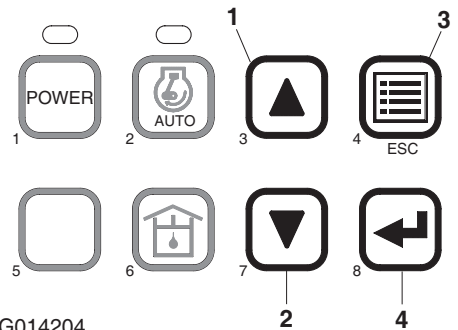

FG014204

Figure 23

### Normal Mode Screen

**NOTE:** Normal mode screen can display many kinds of display mode by selecting, for example, engine speed (RPM), battery voltage (VOLT), front pump pressure (BAR), rear pump pressure (BAR) and so on by selecting.

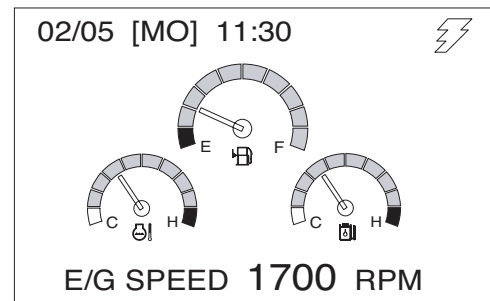

FG000043

Figure 24

## Special Menu Screen

**NOTE:** Displayed language on the special menu screen consists of Korean and English.

If any language except for Korean is selected during language selection mode of main menu, only English will be displayed on special menu screen.

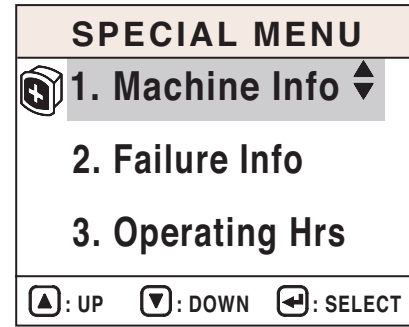

FG000558

Figure 25

## Exiting/Escaping Menus

1. If escape button (ESC, 4 on Figure 23) is pressed for more than 1 second, the special menu screen will be returned to the normal mode screen.
2. If this special menu is "ON" without any activity, for more than 20 seconds, it will turn to the normal mode screen.
3. After the turning starter switch to the "OFF" position, turn it back to the "ON" position, and the normal mode screen displayed once again.

## Special Menu Selections

### Submenu Selection Method

Various sub-menus can be selected by pressing "Up (▲, 1 on Figure 23)" and "Down (▼, 2 on Figure 23)" button.

Move the cursor to desired menu and a selected menu will be inverse displayed.

When the selected menu is inverse displayed, press the "Enter (◀, 3 on Figure 23)" button for menu selection.

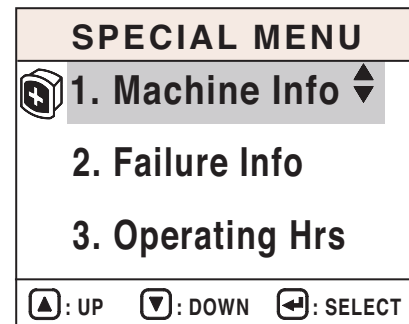

FG000558

Figure 26

## Information of Machine Status

1. Entering Sub-menus: When cursor is located on "Machine Info" of special menu screen, press "Enter (◀, 3 on Figure 23)" button and the "Machine Info" will be displayed.
2. Exiting Sub-menus: If escape button (ESC, 4 on Figure 23) is pressed for more than 1 second, display will be turned to previous screen.

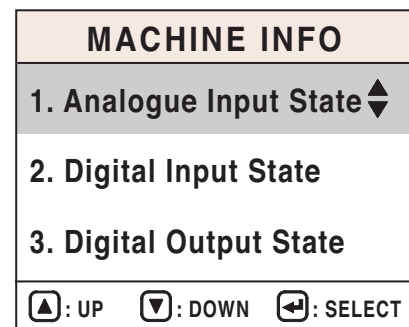

FG000559

Figure 27

**Analog Inputs Description**

Analog Input Items	Display	Remark
1. Pump P/V	mA	Current in pump proportional valve.
2. Cooling Fan P/V	mA	N.A.
3. Flow Control P/V	mA	Current in flow control proportional valve.
4. Dial	mV	Indicating dial voltage.
5. TPS	mV	N.A.
6. E/G Control Motor	mV	N.A.
7. Boom Pressure	BAR	Boom cylinder head pressure.
8. Pilot Gear Pump Press	BAR	N.A.
9. Boost Pressure	BAR	Pump pressure for boost.
10. Intake Manifold Temperature	°C	Temperature of air incoming to intake manifold.
11. E/G Oil Pressure	BAR	Engine oil pressure.
12. Fuel Temperature	°C	Fuel temperature.
13. E/G Oil Temperature	°C	Engine oil temperature.
14. Load At Cur. Spd	%	Current load ratio of equipment.

**Submenu Selections**

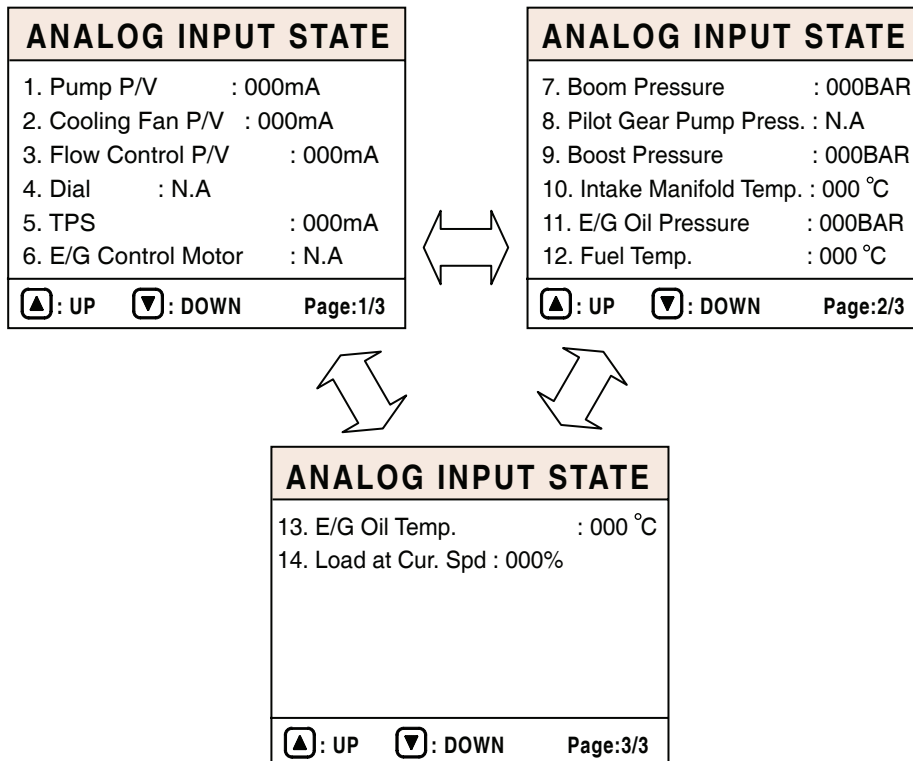

FG003928

**Figure 28**

## Digital Inputs Descriptions

Digital Inputs Items	Mark	Remark
1. Alternator	ON / OFF	Lights up when output at alternator "R(I)" terminal is above 12 ±1V.
2. Travel Select SW		N.A. (only for wheel type equipment)
3. High Speed Sel. SW (M)		Lights up when the travel speed selector switch is set to the "I" position.
4. High Speed Sel. SW (A)		Lights up when the travel speed selector switch is set to the "II" position.
5. Pressure SW (Py)		Lights up when the pressure switch (Py) is "ON."
6. Pressure SW (Px)		Lights up when the pressure switch (Px) is "ON."
7. E/G Oil Press. SW		Lights up when the engine oil pressure switch is "ON."
8. Air Cleaner Clogged		Lights up when the air cleaner indicator contact is "ON."
9. Return Filter Clogged		Lights up when the return filter pressure switch is "ON."
10. Pilot Filter Clogged		Lights up when the pilot filter pressure switch is "ON."
11. OWD Warning SW		Lights up when the overload warning selector switch is "ON."
12. Brake Oil Press. SW		N.A. (only for wheel type equipment)
13. Pedal Press. SW		Lights up when the pedal pressure switch is ON.
14. One Way Sel. SW		Lights up when the selector switch is turned to breaker.
15. Two-way Sel. SW		Lights up when the Selector Switch is turned to "SHEAR."
16. Power Max. SW		Lights up when the boost button is "ON" with the Select switch turned to "BOOST."
17. Breaker SW		Lights up when the boost button is "ON" with the selector switch turned to "BREAKER."
18. Preheat Select		Lights up during preheating (CN5-2) terminal voltage is below 2V.
19. Quick Coupler		Lights up when the Quick Coupler switch is "ON."
20. F and R Lever		N.A. (only for wheel type equipment)
21. Preheat Select		N.A.
22. Reverse Fan SW		N.A.
23. Pilot Cutoff SW		Lights up when pilot cutoff switch is "ON."

**Menu Select**

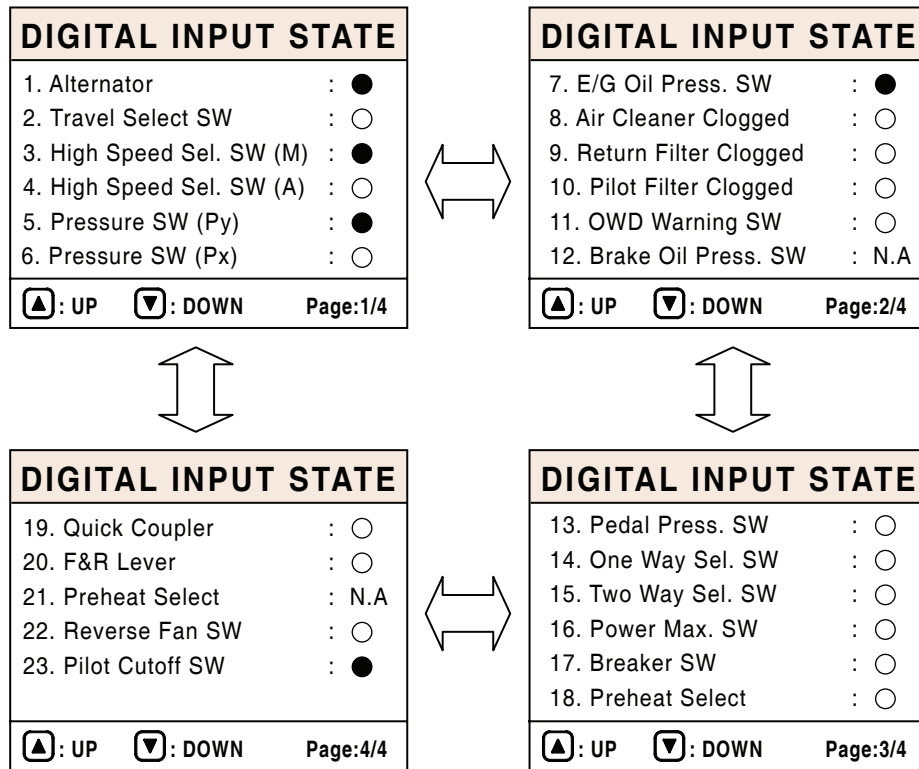

FG003929

**Figure 29**

## Digital Outputs Descriptions

Digital Outputs Items	Mark	Remark
1. Relief Press. Up S/V	ON / OFF	Lights up when the relief press up solenoid valve is "ON."
2. High Speed S/V		Lights up when the high speed solenoid valve is "ON."
3. Reverse Fan S/V		N.A.
4. Starter Relay		When the starter relay is "ON."
5. After Heat Relay		N.A.

## Menu Select

DIGITAL OUTPUT STATE	
1. Relief Press. Up S/V	: ●
2. High Speed S/V	: ○
3. Reverse Fan S/V	: N.A
4. Starter Relay	: ●
5. Afterheat Relay	: N.A
▲: UP ▼: DOWN Page:1/1	

FG014293

Figure 30

## Failure Information

- Entering Sub-menus: When a cursor is located in "Failure Info" of special menu screen press enter button (↵, 3 on Figure 23) and "Failure Info" screen is displayed.
- Exiting Sub-menus: If escape button (ESC, 4 on Figure 23) is pressed for more than 1 second, this information screen will be returned to previous screen.

SPECIAL MENU	
1. Machine Info	
2. Failure Info	◆
3. Operating Hrs	
▲: UP ▼: DOWN ↵: SELECT	

FG000563

Figure 31

- \* Real-time Failure:  
Current status of failure is displayed.
- \* Failure Log:  
Memorized record of past failure is displayed.
- \* Delete Fail Log:  
This mode is used to delete all of the memorized record of past failure.

FAILURE INFO	
1. Realtime Fail	◆
2. Failure Log	
3. Delete Fail Log	
▲: UP ▼: DOWN ↵: SELECT	

FG000564

Figure 32

A. Current failure information

Current status of failure is displayed (Failure code, failure contents).

When a number of failures are produced, failure information can be checked using "UP" (▲, 1 on Figure 23) or "DOWN" (▼, 2 on Figure 23) button.

\* 1/2: A serial number of current failure/ total quantity of failure.

\* Vxxx-xx: Vxxx is a unique code and xx is a FMI (Failure Mode Identifier) number.

- V: Machine related failure code
- E: Engine related failure code

Refer to the failure information code for unique codes and FMI numbers.

This example shows one of two failures.

B. Past failure information

Memorized record of past failure is displayed (Failure code, failure contents).

When a number of failures are produced, failure information can be checked using "UP" (▲, 1 on Figure 23) or "DOWN" (▼, 2 on Figure 23) button.

**NOTE:** " Number: xxx ": "xxx" means that the totally counted number of the same failure.

" Period:xxxxxHrxxm ": It indicates the period for which machine has operated until a failure takes place. (For more than two occurrences of the same failure, until the first occurrence time.)

C. Failure record deletion

This mode is used to delete the memorized record of past failure. If this mode is selected, all records will be deleted.

When "YES" (←, 3 on Figure 23) button is pressed, the memorized record will be deleted.

At this time, deletion signal will be displayed and the screen will move to previous menu after deletion.

This screen will be displayed during 3 seconds.

REALTIME FAIL	
1/2	CODE : V204-05
2/2	CODE : E011-04
Relief Pressure Up S/V	
Current below normal (CURRENT BELOW NORMAL or open circuit)	
▲: UP	▼: DOWN

FG000565

Figure 33

FAILURE LOG	
1/2	CODE : V204-05
2/2	CODE : E011-04
Period:00254Hr 29m Number:08	
Relief Pressure Up S/V	
Current below normal (CURRENT BELOW NORMAL or open circuit)	
▲: UP	▼: DOWN

FG000566

Figure 34

DELETE FAIL LOG	
▲ All Fail Log will be DELETED.	
←: Yes	ESC: No

FG000567

Figure 35

Input your password with one of No. 1 - 8 switches.

When "NO" (ESC, 4 on Figure 23) button is pressed, the screen will recover to previous menu without deletion.

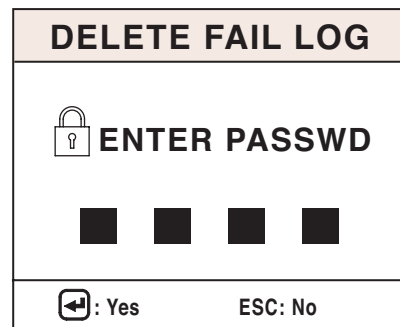

FG000568

Figure 36

Delete Completed screen will appear 3 seconds and the screen will move to Failure Info screen.

It has been shown 3 seconds upon deleting Fail Log.

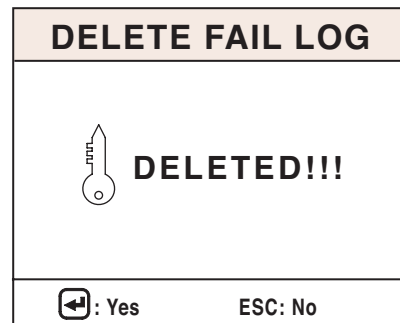

FG000569

Figure 37

The screen shown on the left will appear 3 seconds in case of wrong password input and then Enter Password screen appears again.

It has been shown 3 seconds in case of password failure.

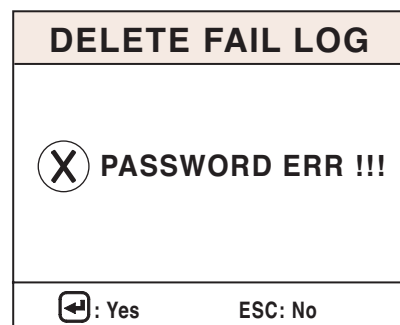

FG000570

Figure 38

### Failure Information Code at Machine Side

Code	Failure Component	Measuring Points	Correct Value		Remarks
			Active	Passive	
V201	Gauge Panel Communication Error	CN7-4 CN7-5	-	R = 60 ±5 Ω	It is a composite resistance of CAN line. This value has to be measured by connected condition of CAN line.
V202	Ecu Communication Error	CN4-4 CN4-5	-	R = 60 ±5 Ω	
V210	Pump P/V	CN1-10 CN1-21	-	R = 18 ±2 Ω (25°C (77°F))	Pump proportional pressure reducing valve.
V211	Cooling Fan P/V		-	-	N.A.
V212	Flow Control P/V	CN1-19 CN1-20	-	R = 14 ±2 Ω (25°C (77°F))	Flow control proportional pressure reducing valve.
V213	Relief Pressure Up S/V	CN1-1 CN1-11	V = V_volt (Note 4.)	R = 26.2 ±2 Ω (25°C (77°F))	Breaker/boost/shear selector switch has to be selected as a boost function and the boost switch on the right-hand joystick is "ON" status.
V214	High Speed S/V	CN1-1 CN1-12	V = V_volt	R = 26.2 ±2 Ω (25°C (77°F))	Voltage is only measured when the pressure switch (Py) is turned "ON."
V215	Swing Priority S/V	CN1-1 CN1-13	V = V_volt	R = 26.2 ±2 Ω (25°C (77°F))	Work mode has to be selected as a trenching mode.
V216	Reverse Fan Speed S/V		-	-	N.A.
V217	Starter Relay	CN1-1 CN1-15	V = V_volt	-	It has to be measured in engine start up state.
V218	After Heat Relay	1-16 1-04	-	-	N.A.

Code	Failure Component	Measuring Points	Correct Value		Remarks
			Active	Passive	
V220	Front Pump Press. Sensor	CN3-1 CN3-2	V = IV	-	It has to be measured in engine stop state.
V221	Rear Pump Press. Sensor	CN3-3 CN3-4	V = IV	-	
V222	Hyd. Oil Temperature Sensor	CN3-9 CN3-10	-	R = 2.45 ±0.25 kΩ (25°C (77°F)) R = 320 ±32 Ω (80°C (176°F))	
V223	Water Temperature Sensor		-	-	N.A.
V224	Engine Speed Sensor		-	-	N.A.
V225	Fuel Level Sensor	CN3-7 CN3-8	-	Empty: 5 ±0.25 kΩ Full: 320 ±32 Ω	
V226	Alternator Potential	CN2-14 CN1-8	V = 2 ±1V	-	It has to be measured in engine stop state.
V227	Dial	CN3-16 CN3-7	-	R = 1.0 ±0.3 kΩ R = 4.0 ±1.5 kΩ	
V228	Tps (Wheel)		-	-	N.A.
V229	Parking Brake Press. Sensor		-	-	N.A.
V230	E/g Control Motor Sensor		-	-	N.A.

- NOTE:**
1. Active value: Starter switch has to be turned "ON"  
Measuring points between component and wire harness have to be connected.
  2. Passive value: Starter switch has to be turned "OFF"  
Measuring points between component and wire harness have to be disconnected.
  3. Measuring points are engine controller's points and passive value is each component's value.
  4. V\_batt: Source power of equipment.

**FMI (Failure Mode Identifier)**

<b>FMI 0</b>	Above normal range (DATA VALID but ABOVE NORMAL OPERATIONAL RANGE)
<b>FMI 1</b>	Below normal range (DATA VALID but BELOW NORMAL OPERATIONAL RANGE)
<b>FMI 2</b>	Incorrect signal (DATA ERRATIC, INTERMITTENT OR INCORRECT)
<b>FMI 3</b>	Voltage above normal (VOLTAGE ABOVE NORMAL OR SHORTED TO HIGH SOURCE)
<b>FMI 4</b>	Voltage below normal (VOLTAGE BELOW NORMAL OR SHORTED TO LOW SOURCE)
<b>FMI 5</b>	Current below normal (CURRENT BELOW NORMAL OR OPEN CIRCUIT)
<b>FMI 6</b>	Current above normal (CURRENT ABOVE NORMAL OR GROUNDED CIRCUIT)
<b>FMI 8</b>	Abnormal signal (ABNORMAL FREQUENCY OR PULSE WIDTH OR PERIOD)
<b>FMI 11</b>	Failure mode not identifiable (ROOT CAUSE NOT KNOWN - Malfunction)
<b>FMI 31</b>	NOT AVAILABLE OR CONDITION EXISTS

**Information of Machine Operation**

Accumulated operation hour of each mode and status is displayed.

1. Operating Hour Information

- A. Entering Sub-menus: When a cursor is located in "Operating Hrs" of special menu screen (Figure 39) press enter button (↵, 3 on Figure 23) and "Operating Hrs" screen will be displayed (Figure 40).

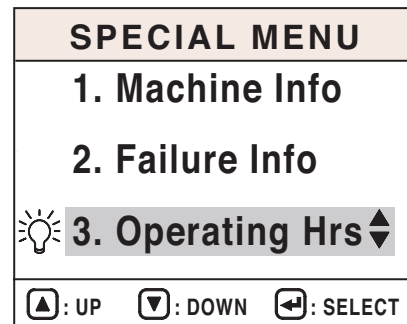

FG000571

Figure 39

- B. Information screen of machine operation (Figure 40).

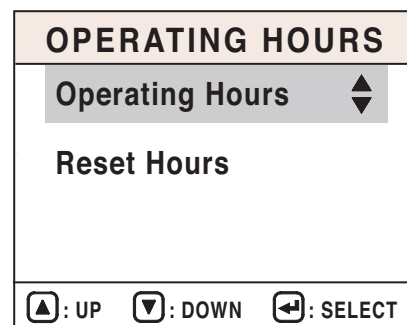

FG000572

Figure 40

- C. Operating Hours Screen
- D. Exiting Sub-menus: If escape button (ESC, 4 on Figure 23) is pressed for more than 1 second, this information screen will be returned to previous screen.

<b>OPERATING HOURS</b>	
1. Power	: 00042 Hr
2. Auto idle	: 00005 Hr
3. Travel speed	
I speed	: 00007 Hr
II speed	: 00001 Hr
<span>▲</span> : UP <span>▼</span> : DOWN <span>⏏</span> : SELECT	

FG014294

**Figure 41**

**Information contents of operation hour**

Item	Information Contents	Detection Method
Power Mode	Operation hours used power mode are displayed.	Power mode switch (Instrument panel) - "ON" status and Alternator signal (CN2-14) is "HI"
Auto Idle	Operation hours used auto idle status are displayed.	Auto idle switch (Instrument panel) - "ON" status and Alternator signal (CN2-14) is "HI"
Travel Speed: -1st - 2nd	Operation hours used low speed and high speed are displayed.	1st: High speed s/v "OFF" status 2nd: High speed s/v and travel pressure switch "Py" (control valve) - "ON" status.
Hydraulic Oil Temperature Distribution (°C (°F))	Temperature of hydraulic oil is classified 6 steps. And operation hours of each step are displayed  Under 30°C (87°F) 31 - 50°C (88 - 123°F) 51 - 75°C (124 - 168°F) 76 - 85°C (169 - 186°F) 86 - 95°C (187 - 203°F) Over 96°C (204°F)	The resistance delivered from temperature sensor of hydraulic oil is classified 6 steps. And operation hours of each step are displayed. (Alternator output HI status)
Coolant Temperature Distribution (°C (°F))	Temperature of coolant is classified 6 steps. And operation hours of each step are displayed.  Under 40°C (105°F) 41 - 60°C (106 - 141°F) 61 - 85°C (142 - 186°F) 86 - 95°C (187 - 204°F) 96 - 105°C (205 - 222°F) Over 106°C (223°F)	The resistance delivered from coolant sensor is classified 6 steps. And operation hours of each step are displayed. (Alternator output HI status)

**Menu Selection of Operation Hour Information**

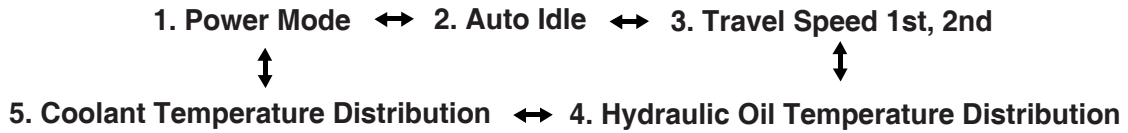

FG014295

Figure 42

**Example of Machine Operation Info Screen**

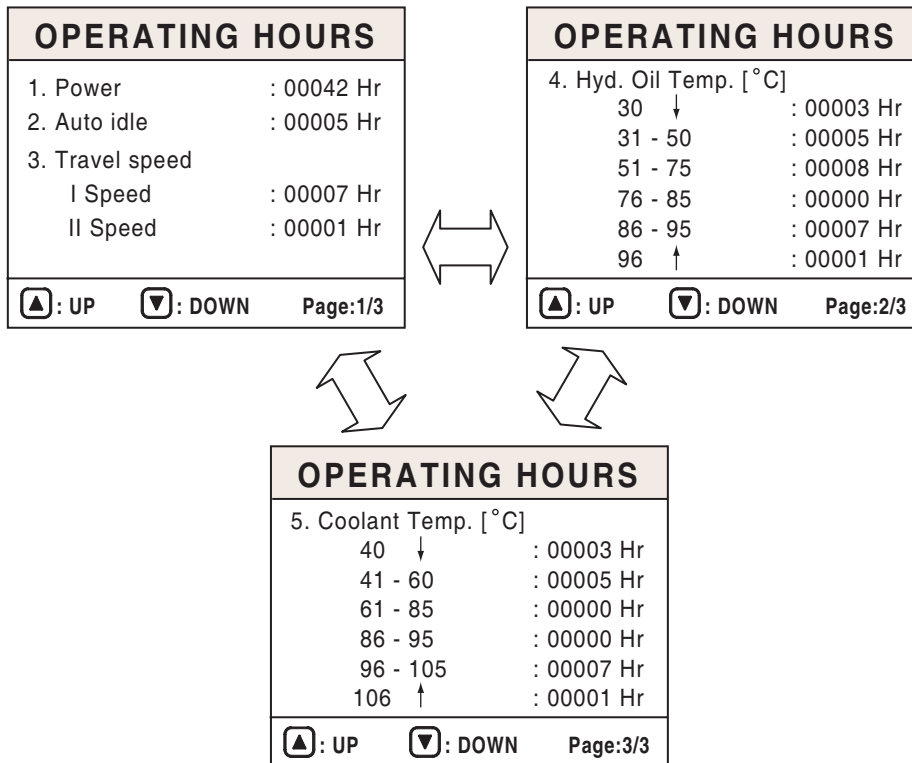

FG014296

Figure 43

2. Operation hour reset

- A. Entering Sub-menus: When cursor is located in "Reset Hrs" of information screen of operating hours press enter button (↵, 3 on Figure 23) and "Machine Operation Info" screen will be displayed.

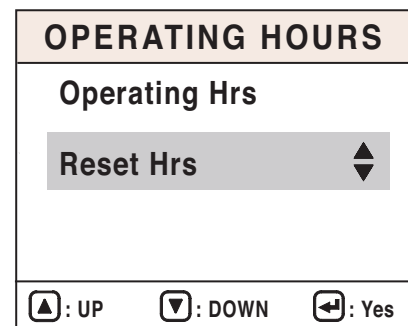

FG000578

Figure 44

- B. Reset screen of operation hour
- C. Exiting Sub-menus: If escape button (ESC, 4 on Figure 23) is pressed for more than 1 second, this information screen will be returned to previous screen.

**NOTE:** When "YES" (←, 3 on Figure 23) button is pressed, operation hours will reset. At this time, resetting signal will be displayed and the screen will move to previous menu after resetting.

**NOTE:** When "NO" (ESC, 4) button is pressed, the screen will recover to previous menu without resetting.

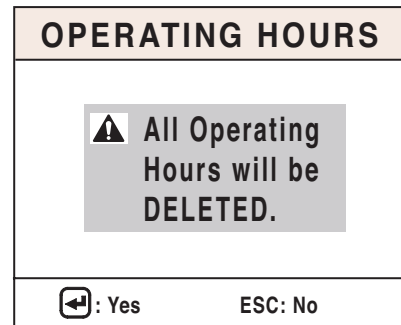

FG000579

Figure 45

### Machine Operation Info Screen

1. If you press the YES" (←, 3 on Figure 23) button, password entrance screen appears.

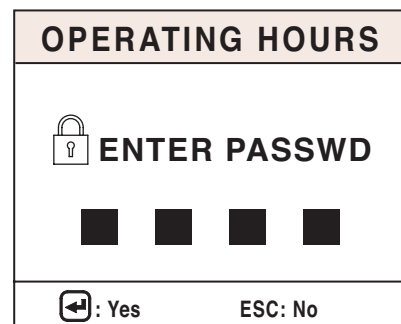

FG000576

Figure 46

2. When right password is input, machine operation periods will be deleted and Reset Completed screen will appear 3 seconds.

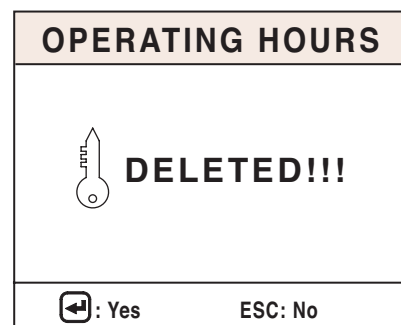

FG000577

Figure 47

3. If you press the "NO" (ESC, 4) button, the previous screen appears without resetting operation periods.

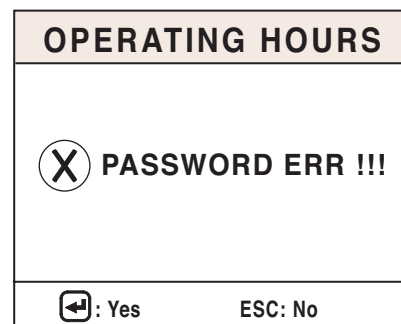

FG001086

Figure 48

# ELECTRONIC HYDRAULIC CONTROL SYSTEM (e-EPOS)

## Control System Schematic

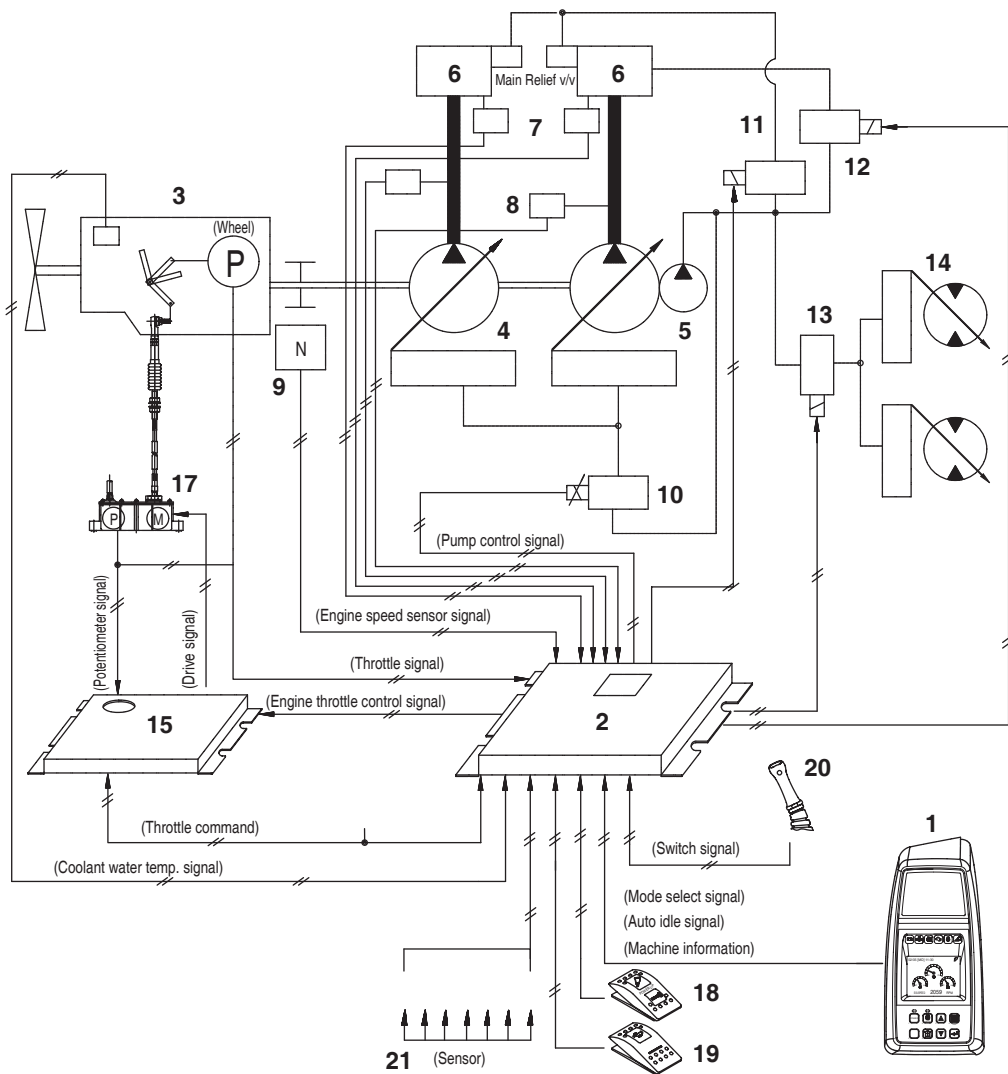

Figure 49

FG014292

Reference Number	Description
1	Instrument Panel
2	e-EPOS Controller
3	Engine
4	Main Pump
5	Aux Pump
6	Control Valve
7	Pressure Switch
8	Pump Pressure Sensor
9	Engine Speed Sensor
10	Electromagnetic Proportional Pressure Reducing Valve
11	Solenoid Valve (Boost)

Reference Number	Description
12	Solenoid Valve (Swing Priority)
13	Solenoid Valve (High Speed)
14	Travel Motor
15	Engine Throttle Controller
16	Engine Control Dial
17	Engine Control Motor
18	Breaker/Boost/Shear Selector Switch
19	Auto Travel Selector Switch
20	Boost Switch (Right Work Lever)
21	Sensor

# POWER MODE CONTROL

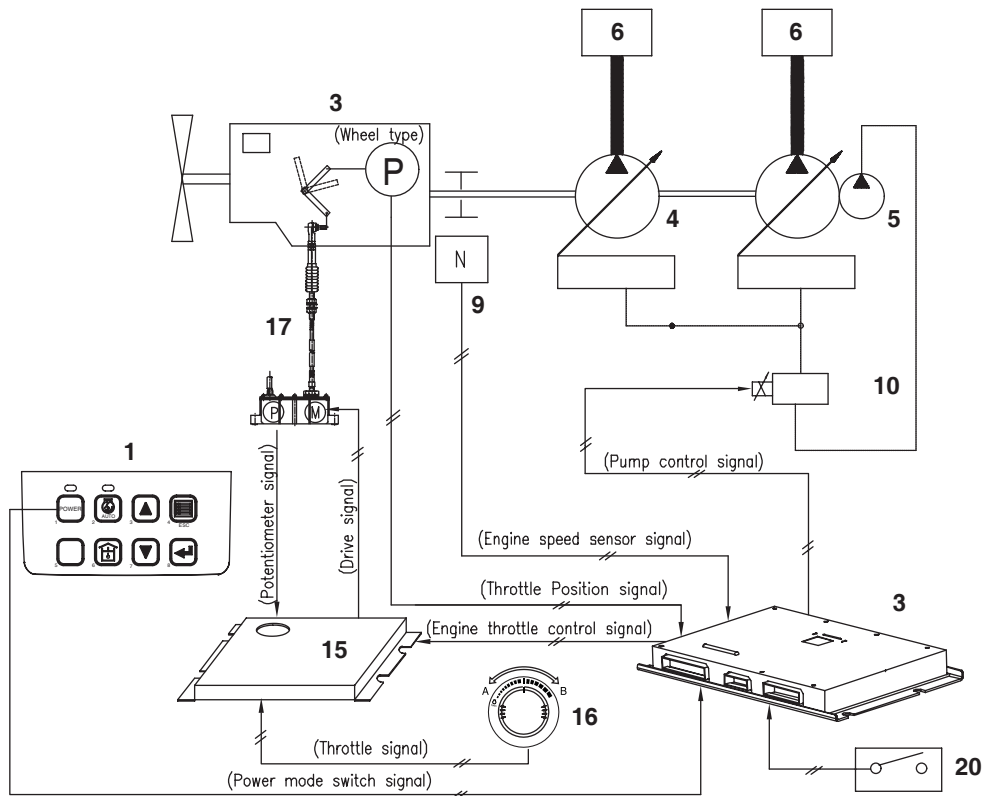

FG014334

Figure 50

Reference Number	Description
1	Instrument Panel (Power Mode Selector Switch)
2	e-EPOS Controller
3	Engine
4	Main Pump
5	Aux Pump
6	Control Valve

Reference Number	Description
9	Engine Speed Sensor
10	Electromagnetic Proportional Pressure Reducing Valve
15	Engine Throttle Controller
16	Engine Control Dial
17	Engine Control Motor
20	Work/Travel Selector Switch (Wheel type)

The power mode switch permits the selection of the appropriate engine power depending on the working condition. One of the two, Power Mode or Standard Mode, setting can be selected. When the engine starter switch is turned "ON," the power mode is automatically defaulted to standard mode. The desired mode can be selected by pressing the selector button on the instrument panel. When the power mode is selected, the indicator light will turn "ON" to display the selected mode.

The quantity of oil discharged by the pump and the engine speed are determined by the mode selected by the operator. The pump output in each mode is determined by the mode selection and is listed in the following table

<b>Mode</b>	<b>Standard Mode</b>	<b>Power Mode</b>
<b>Output (%)</b>	Approximately 85%	100%

# Operation

## 1. Power Mode

This mode should be selected for high speed work. In this mode the engine output is most efficiently utilized due to the discharged oil volume being controlled based on the equivalent horsepower curve at various loaded pressures. The e-EPOS controller compares the target engine speed with the actual engine speed and controls the signal to the E.P.P.R. (Electromagnetic Proportional Pressure Reducing) valve which in turn varies the pump output quantity.

If the load increases, the engine speed will fall below the rated speed. When this occurs, the controller senses this decrease and immediately reduces the pump discharge volume to maintain the engine speed at the rated level.

On the other hand, if the load is decreased the controller increases the discharge volume of the pump to maintain the engine speed at the rated level.

By repeating these control operations, the engine speed is maintained at the rated speed so that maximum power can be generated.

In Power Mode, the e-EPOS controller receives engine speed signals from the engine control dial and the engine controller (ECU) and converts it to an operating signal current and is then transferred to the pump's E.P.P.R valve. At this time the E.P.P.R. valve converts the electric signal to the corresponding control pressure and sends it to the two pumps, adjusting the pump discharge volume to the desired level.

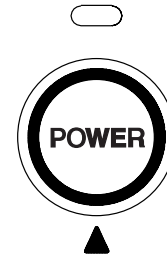
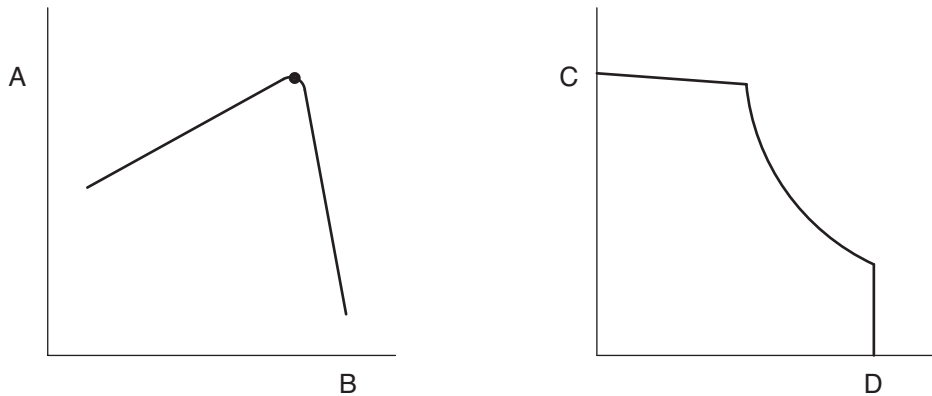

Figure 51

ARO0260L



FG000580

Figure 52

Reference Number	Description
A	Engine Horsepower (hp)
B	Engine Speed (rpm)

Reference Number	Description
C	Pump Discharge Volume (lpm)
D	Pump Discharge Pressure (kg/cm <sup>2</sup> )

## 2. Standard Mode

Standard Mode is used for general work. When this mode is selected it will reduce noise and fuel consumption in comparison with Power Mode. The current to the E.P.P.R. valve is shut off and pump discharge volume is controlled by pump regulator.

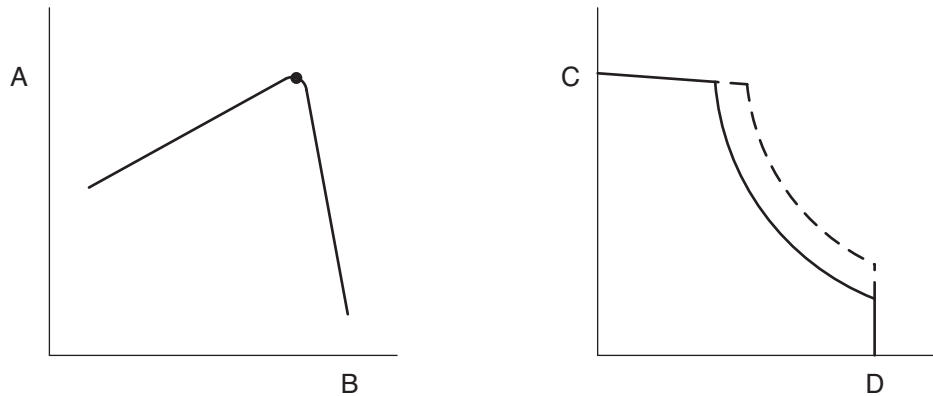

FG000581

Figure 53

Reference Number	Description
A	Engine Horsepower (hp)
B	Engine Speed (rpm)

Reference Number	Description
C	Pump Discharge Volume (lpm)
D	Pump Discharge Pressure (kg/cm <sup>2</sup> )

## 3 Operation in case of failure in the control system (Aux mode operation)

Though it is impossible to control current of the E.P.P.R (Electromagnetic Proportional Pressure Reducing) Valve controlling the discharge volume of pump due to fault in control system, the machine can be operated in the aux mode.

Upon turning "ON" the aux mode switch, the E.P.P.R Valve controlling the discharge volume of pump comes into contact with the aux mode resistor to let current of a certain value flow. At this time, the discharge volume of pump follow the control by the pump regulator, nearly at quantity roughly similar to that in the standard mode.

# POWER MODE CONTROL - CIRCUIT DIAGRAM

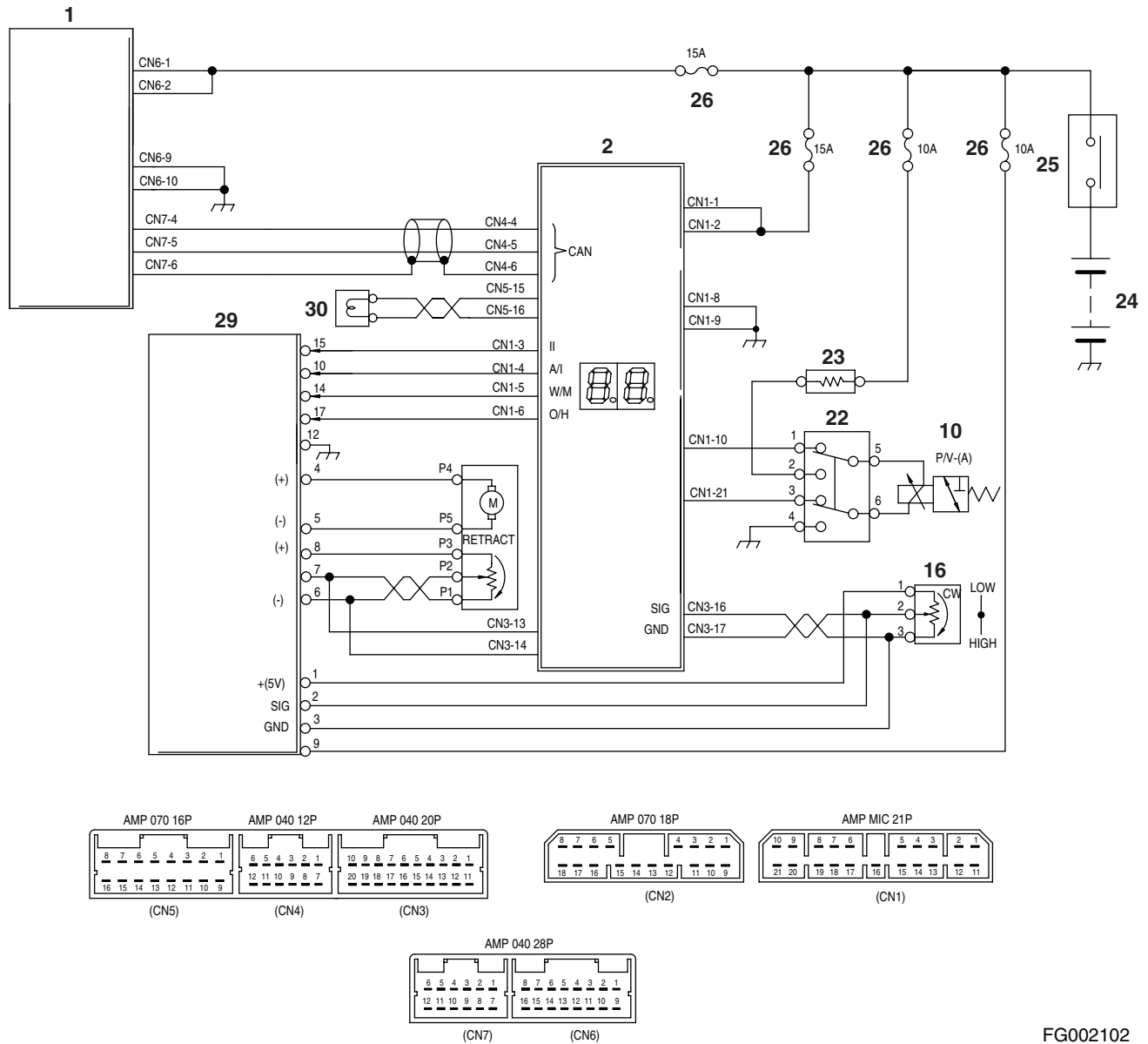

Figure 54

FG002102

Reference Number	Description
1	Instrument Panel
2	e-EPOS Controller
10	E.P.P.R. Valve (Electromagnetic Proportional Pressure Reducing)
16	Engine Control Dial
22	Aux Mode Switch

Reference Number	Description
23	Aux Mode Resistor
24	Battery
25	Battery Relay
26	Fuse
29	Engine Throttle Controller
30	Engine Speed Sensor

# WORK MODE CONTROL

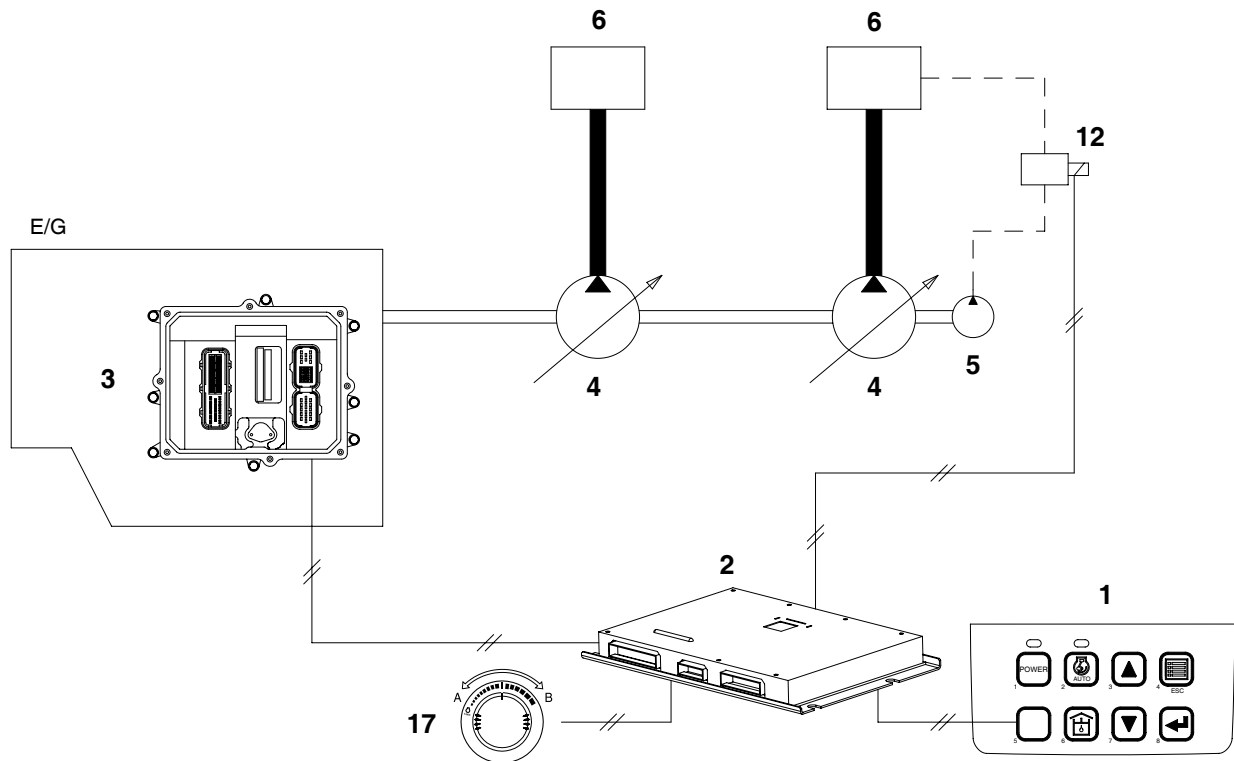

FG014335

Figure 55

Reference Number	Description
1	Instrument Panel (Trenching Mode Selector Switch)
2	e-EPOS Controller
3	Engine Controller
4	Main Pump

Reference Number	Description
5	Aux Pump
6	Control Valve
12	Solenoid Valve
17	Engine Control Dial

Depending on the working condition, one of two work modes, "DIGGING" or "TRENCHING" can be selected from the instrument panel.

When the engine starter switch is turned "ON," the work mode is automatically defaulted to digging mode.

Depending on the trenching mode selected, the control valve solenoid adjusts the assignment of hydraulic oil flow to each device on the equipment.

# WORK MODE CONTROL - CIRCUIT DIAGRAM

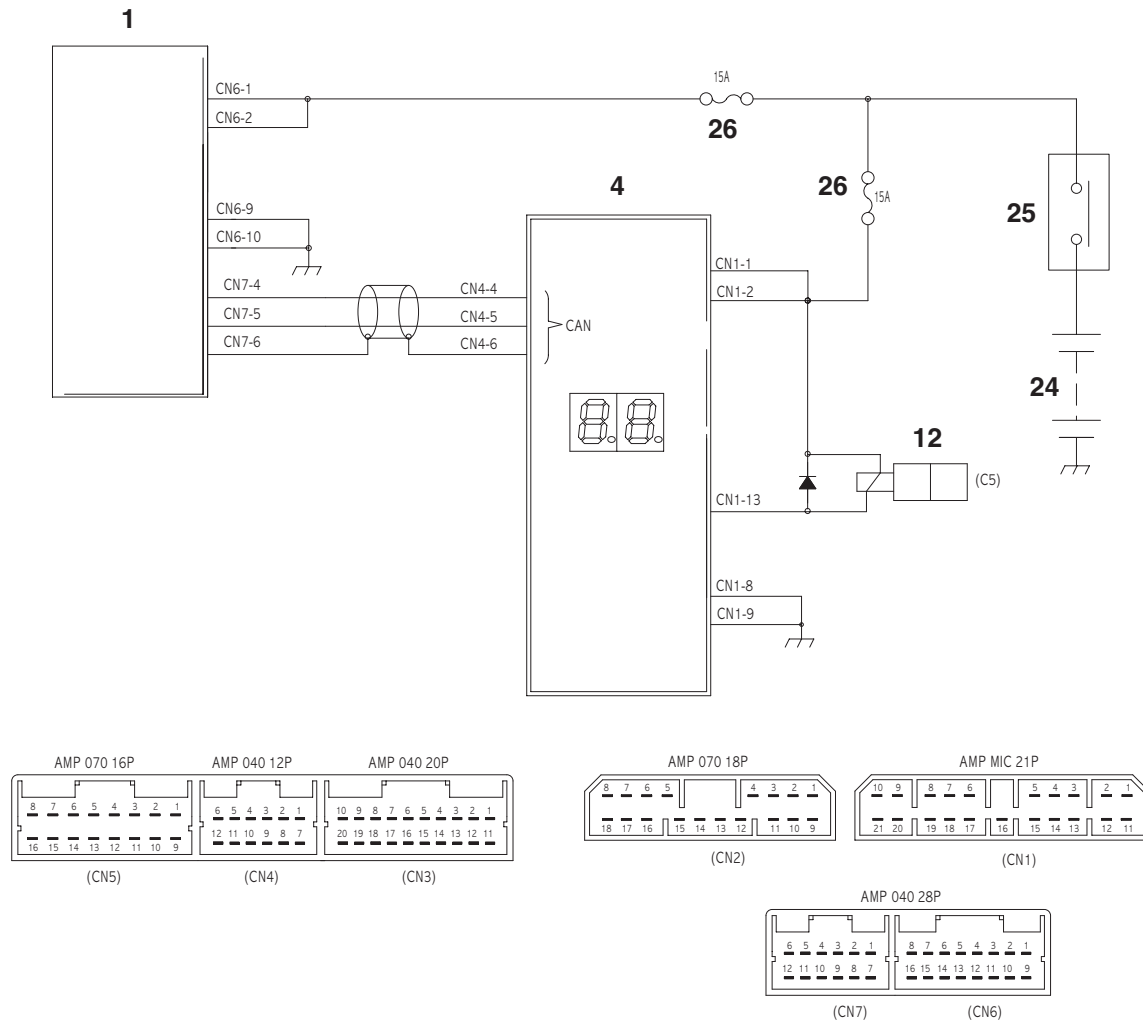

FG000583

Figure 56

Reference Number	Description
1	Instrument Panel
2	e-EPOS Controller
12	Solenoid Valve (Swing Priority)

Reference Number	Description
24	Battery
25	Battery Relay
26	Fuse

# ENGINE CONTROL SYSTEM

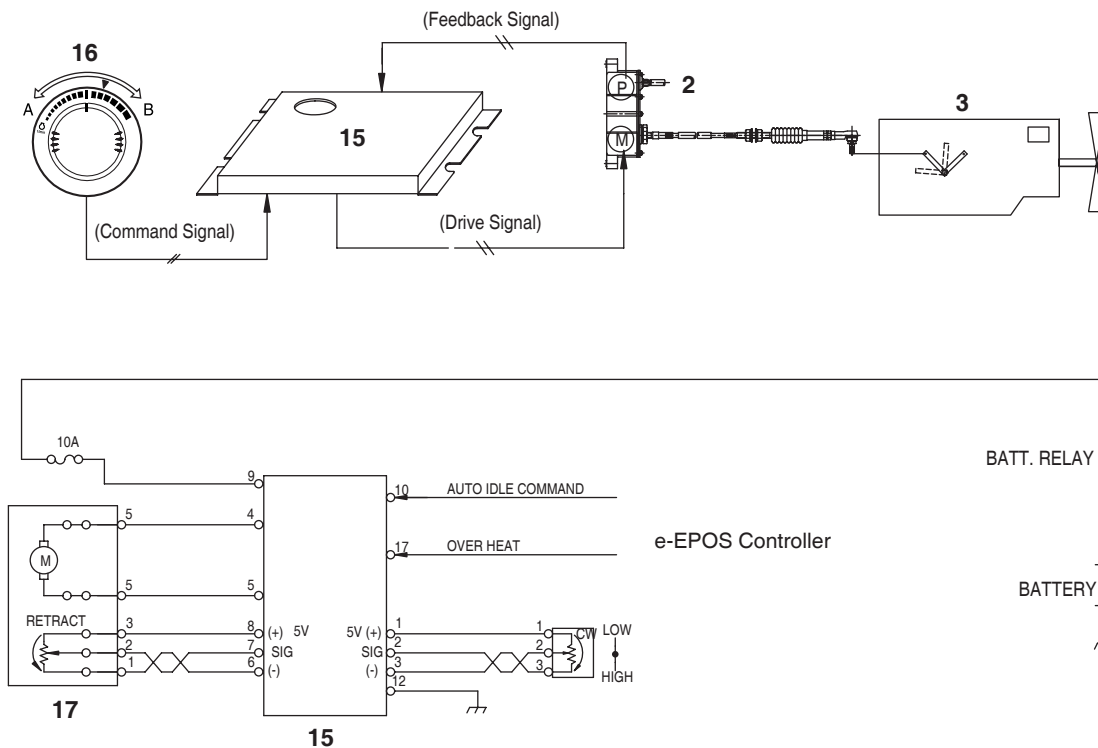

FG014301

**Figure 57**

Reference Number	Description
3	Engine
15	Engine Throttle Controller

Reference Number	Description
16	Engine Control Dial
17	Engine Control Motor

When the engine control dial is moved, the output voltage changes according to the dial position, and this signal enters the engine throttle controller. The engine throttle controller drives the motor according to the dial command position by comparing the value of dial voltage and the value of potentiometer voltage which is used to observe the motor position (Feedback signal) contained within the engine control motor.

The throttle controller stops the motor by cutting off the motor drive current when dial command signal and feedback signal are the same.

A cable is attached to the engine control motor and the end of this cable is connected with the lever which adjusts fuel injection of engine. Thus, this lever is always driven with motor, so the speed of the engine is controlled.

# ENGINE CONTROL DIAL

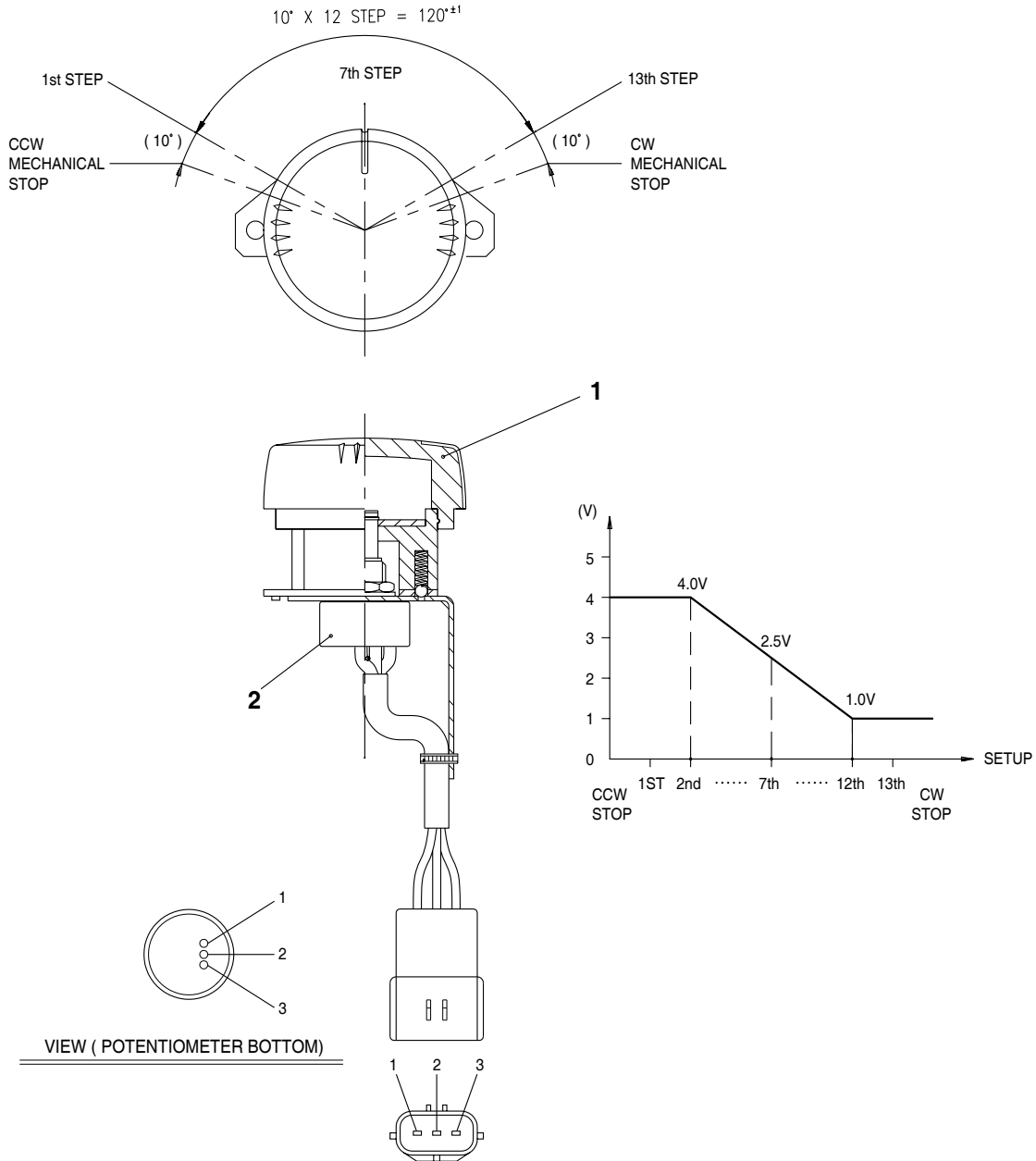

FG000866

**Figure 58**

Reference Number	Description
1	Knob

Reference Number	Description
2	Potentiometer (Variable Resistor)

The engine control dial has a built in potentiometer. When the control knob is moved the output voltage (through "2 and 3" terminals) will vary from the 5 V supplied from the e-EPOS controller as shown in the graph.

# ENGINE CONTROL MOTOR

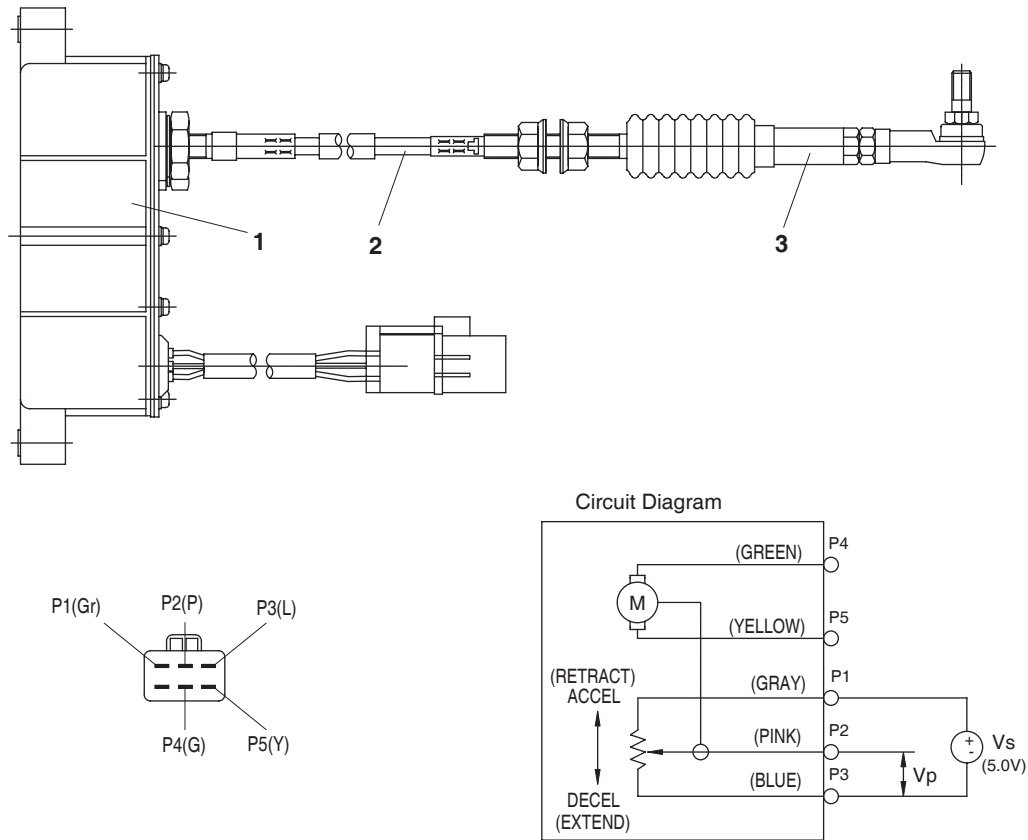

FG014302

**Figure 59**

The engine control motor uses the DC motor and has a potentiometer (a variable resistor) that is used to observe the position within it. When the engine control motor has unusual loads (in case of aging of control cable or folded cable), the engine throttle controller shuts off current to the engine control motor for protecting the system in the event the engine control motor does not drive. In this situation, it can drive normally if the start switch is moved from OFF position to ON position after removing the cause of unusual loads.

**NOTE:** *Change or Adjust the engine control motor in accordance with adjustment way of engine control device. Wrong adjustment causes unexpected performance of the equipment.*

# ENGINE CONTROL CIRCUIT DIAGRAM

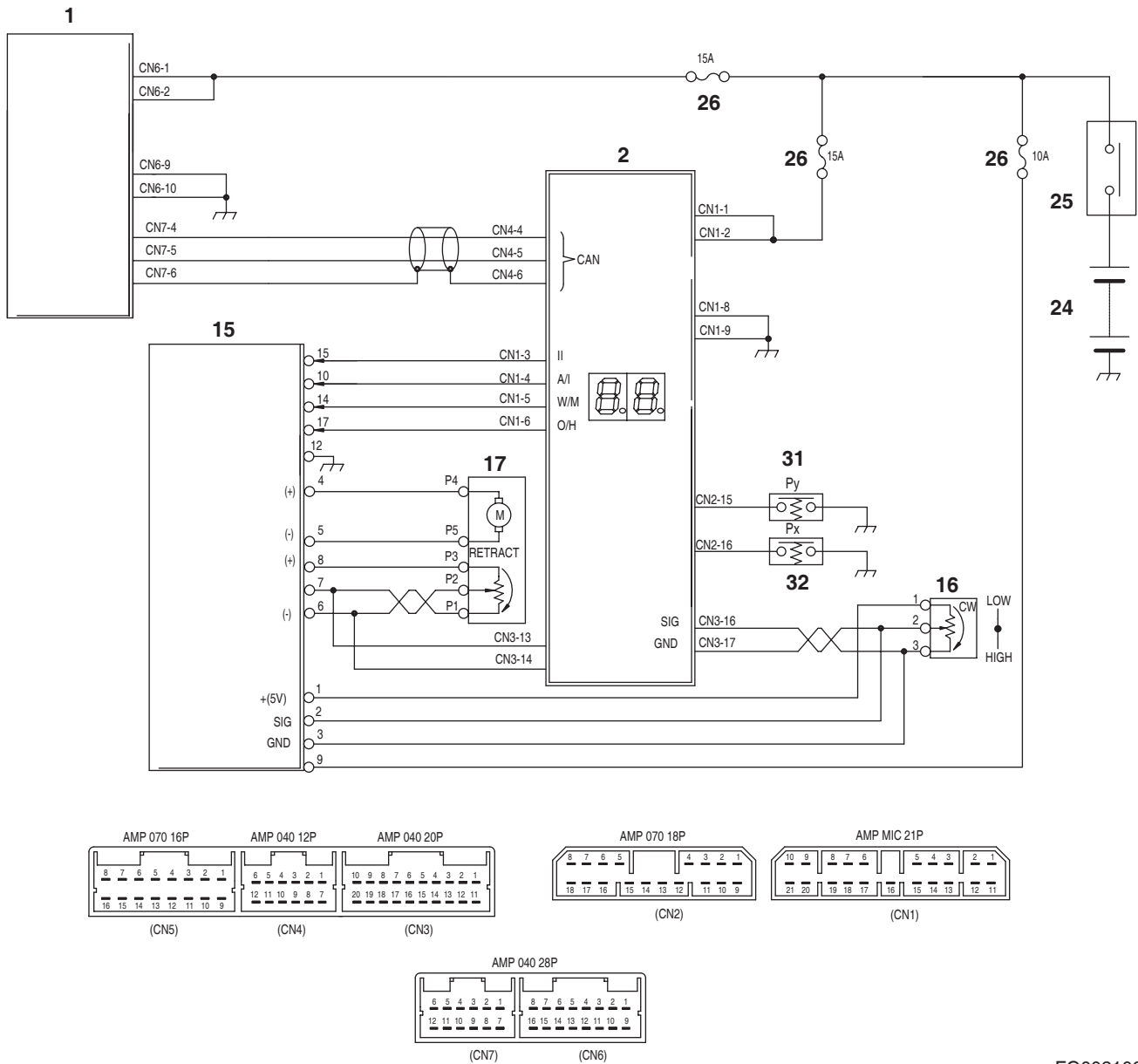

Figure 60

FG002106

Reference Number	Description
1	Instrument Panel
2	e-EPOS Controller
15	Engine Throttle Controller
16	Engine Control Dial
17	Engine Control Motor

Reference Number	Description
24	Battery
25	Battery Relay
26	Fuse
31	Pressure Switch (Py)
32	Pressure Switch (Px)

# AUTOMATIC DECELERATION CONTROL (AUTO IDLE CONTROL)

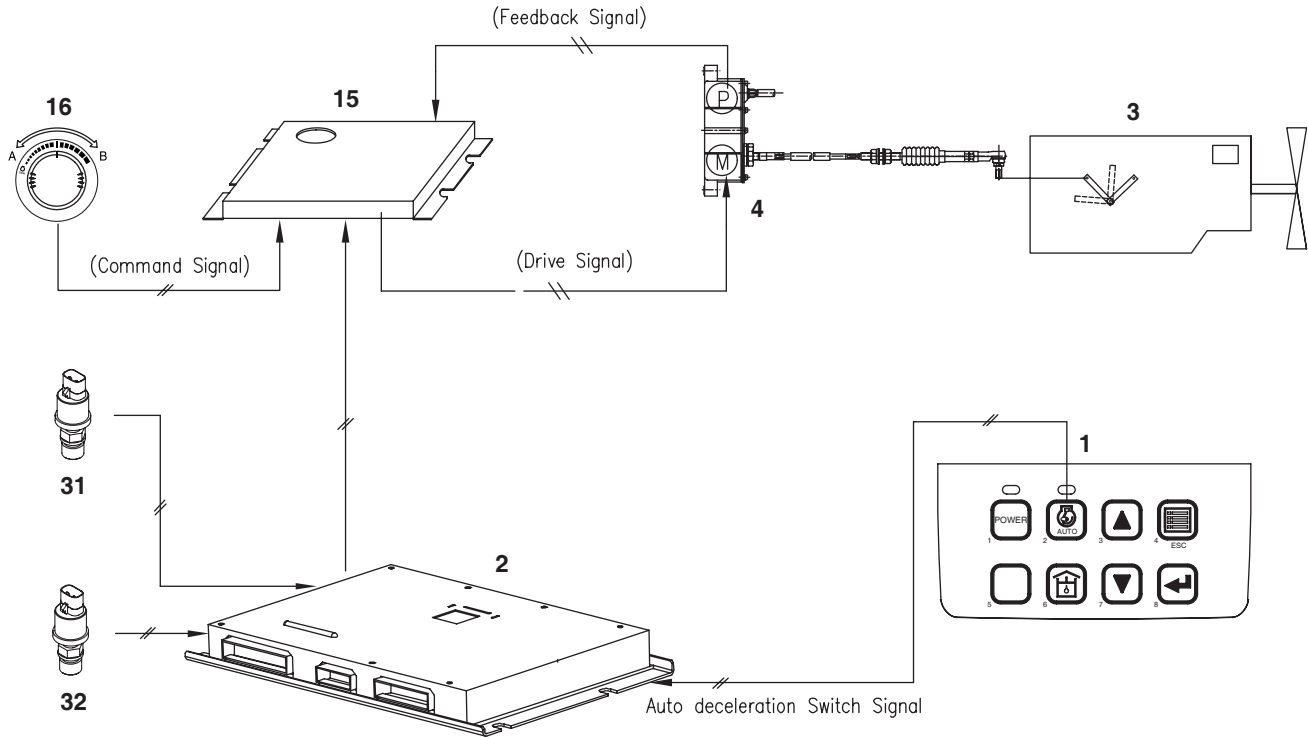

FG014303

Figure 61

Reference Number	Description
1	Instrument Panel (Auto Idle Switch)
2	e-EPOS Controller
3	Engine

Reference Number	Description
15	Engine Throttle Controller
16	Engine Control Dial
31	Pressure Switch
32	Pressure Switch

If the machine is idling without the controls being operated or is waiting for a dump truck the engine speed is automatically lowered. Once the controls are operated and work is being started the machine will be restored to the previous settings. As a result, noise and fuel consumption will be reduced. This function can be selected or cancelled through the Auto Idle Selector Switch on the instrument panel.

The initial setting at start-up is with this switch in the select position. Approximately 4 seconds after this function is selected, if all work levers are in the neutral position, the e-EPOS controller compares the automatic reduction signal with the signal set by engine control dial. The lower of the two signals is selected, the e-EPOS controller sends a signal to the engine controller to control the engine speed.

The neutral status of the machine is detected by the two pressure switches in the control valve. When the work levers are in the neutral position, the switch is in the "OFF" position.

# ENGINE OVERHEAT PROTECTION SYSTEM

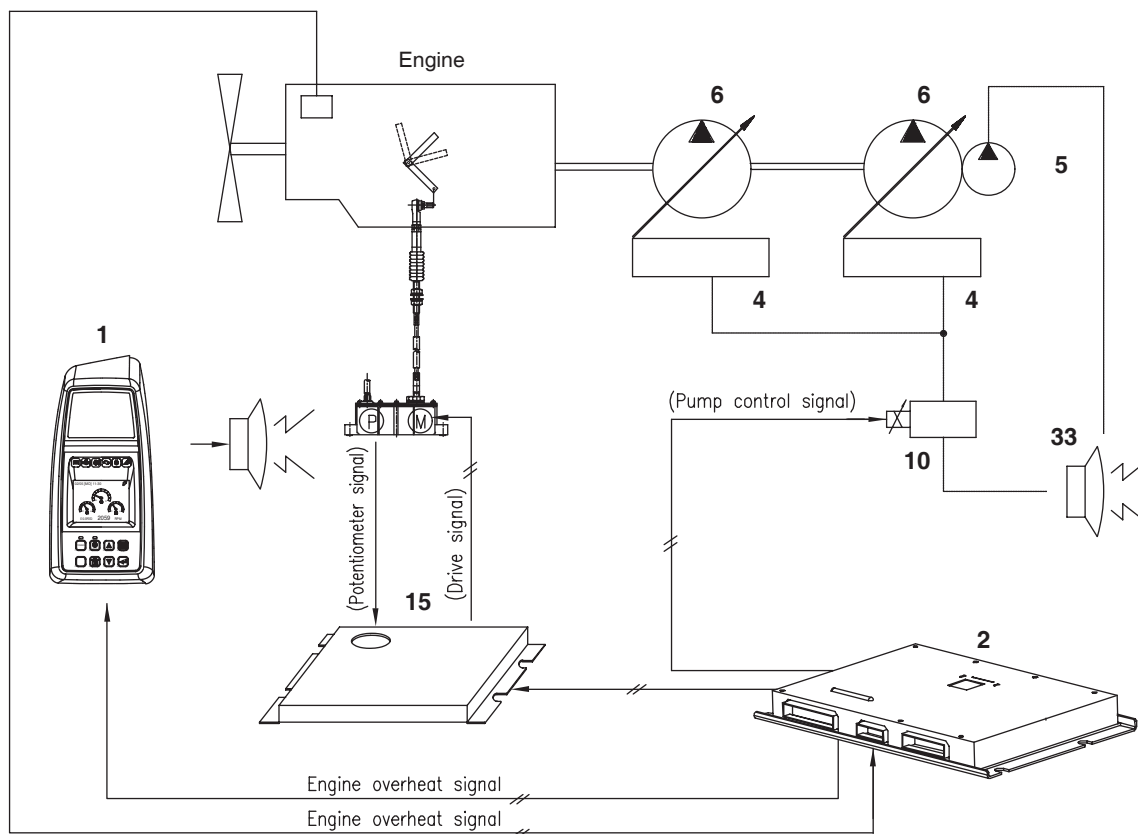

FG014304

Figure 62

Reference Number	Description
1	Instrument Panel
2	e-EPOS Controller
3	Main Pump
4	Aux Pump
6	Control Valve

Reference Number	Description
10	E.P.P.R. Valve (Electromagnetic Proportional Pressure Reducing Valve)
15	Engine Throttle Controller
33	Warning Buzzer

When the engine coolant temperature increases to over 107°C (225°F), the gauge panel detects it from the sensor mounted in the coolant line of engine and send a signal to the e-EPOS controller and turns on the buzzer simultaneously.

The e-EPOS controller returns an overheat signal to the engine throttle controller and changes from power mode to standard mode. The engine speed is then set to a low speed by the engine throttle controller. That is, when the engine coolant temperature increases, a warning buzzer turns on, power mode is changed to standard mode and engine speed set to a low speed.

When coolant temperature falls below 95°C (203°F), normal operation will resume.

# POWER BOOST MODE

## Operation

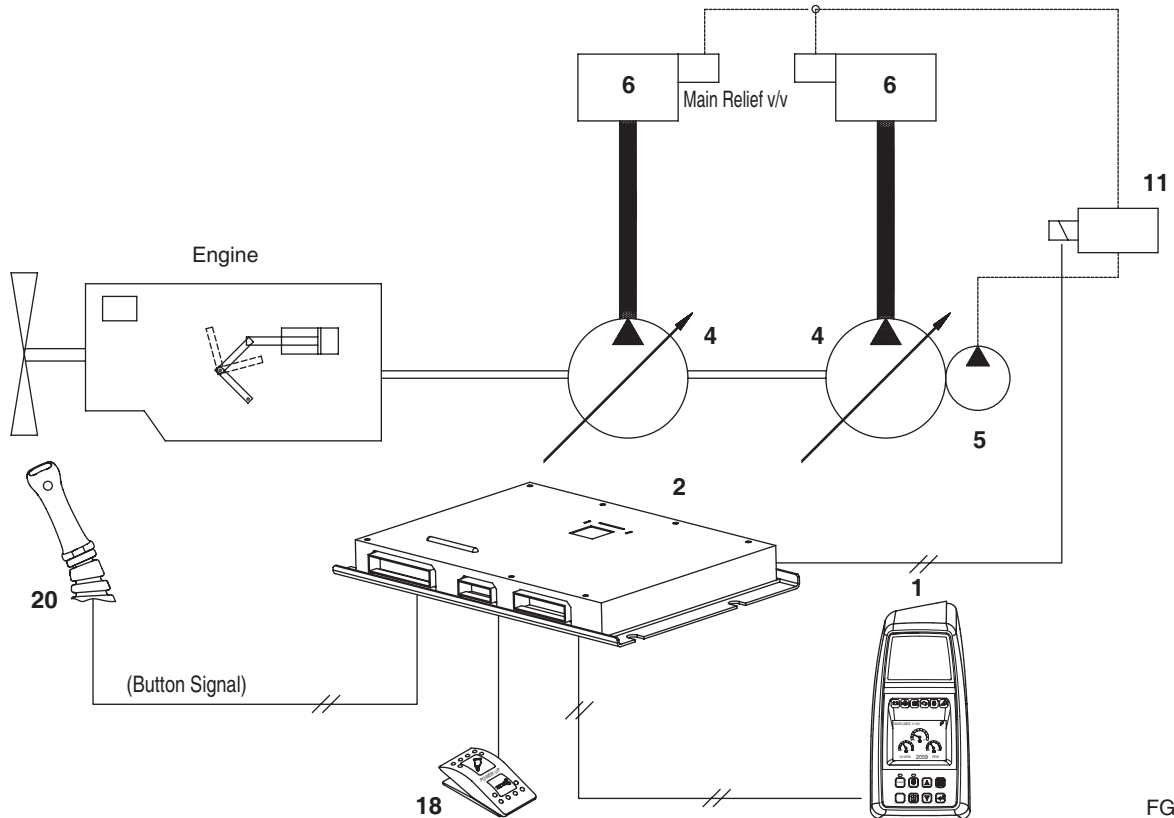

FG014305

Figure 63

Reference Number	Description
1	Instrument Panel
2	e-EPOS Controller
4	Main Pump
5	Aux Pump
6	Control Valve

Reference Number	Description
11	Solenoid Valve (Boost)
18	Breaker/Boost/Shear Selector Switch
20	Power Boost Switch (Top of Right Work Lever)

The Power Boost function is used to temporarily increase the main relief pressure to enhance excavation ability. When the breaker/boost/shear selector switch is set to "BOOST" and the power boost button on the center of the right-hand work lever (joystick) is pressed during work, the e-EPOS controller will activate the power boost solenoid valve and increase the relief valve pressure from 330 - 350 kg/cm<sup>2</sup> (4,700 - 5,000 psi). The excavation ability is increased by approximately 6%.

When the power boost function is in activated, a power boost symbol appears on the information display department of instrument panel.

**NOTE:** Do not use this switch for more than 10 seconds.

# Power Boost Control - Circuit Diagram

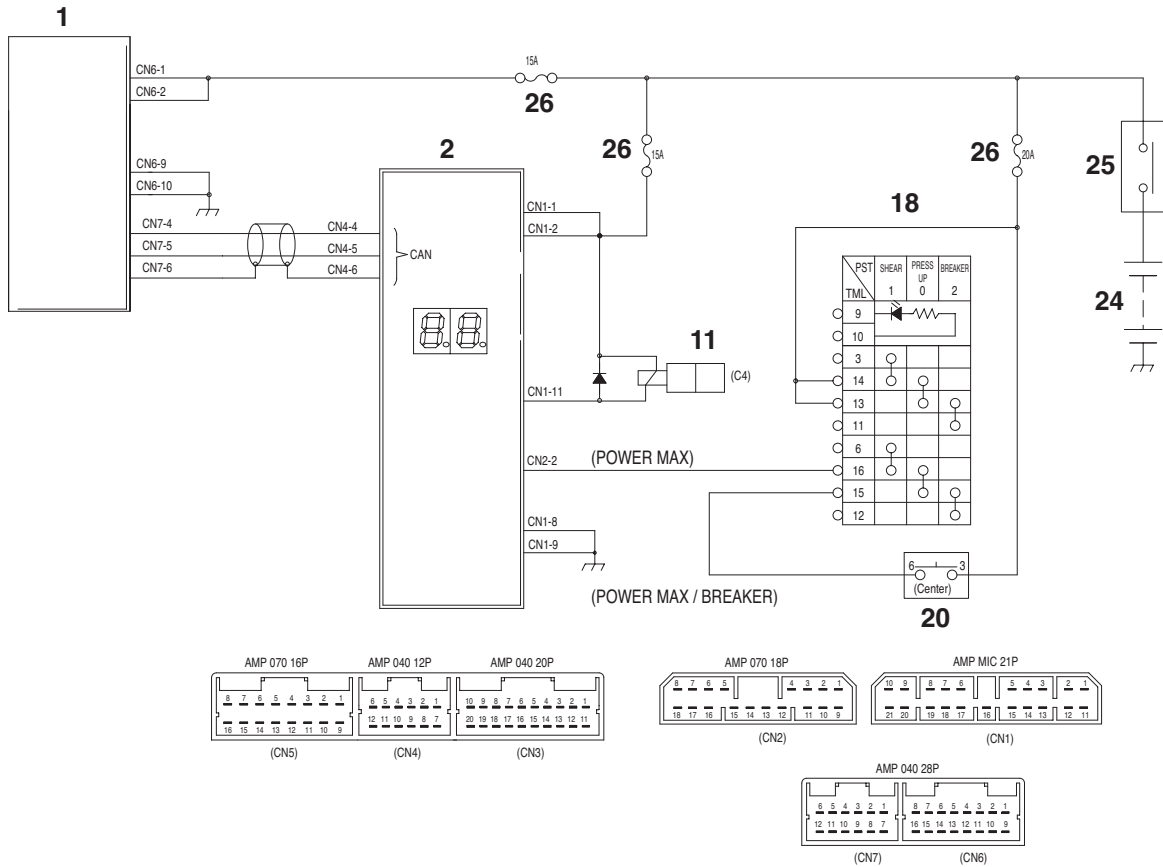

FG000586

Figure 64

Reference Number	Description
1	Instrument Panel
2	e-EPOS Controller
11	Solenoid Valve (Pressure Up)
18	Breaker/Boost/Shear Selector Switch

Reference Number	Description
20	Power Boost Switch (Top of Right Work Lever)
24	Battery
25	Battery Relay
26	Fuse

# AUTOMATIC TRAVEL SPEED CONTROL

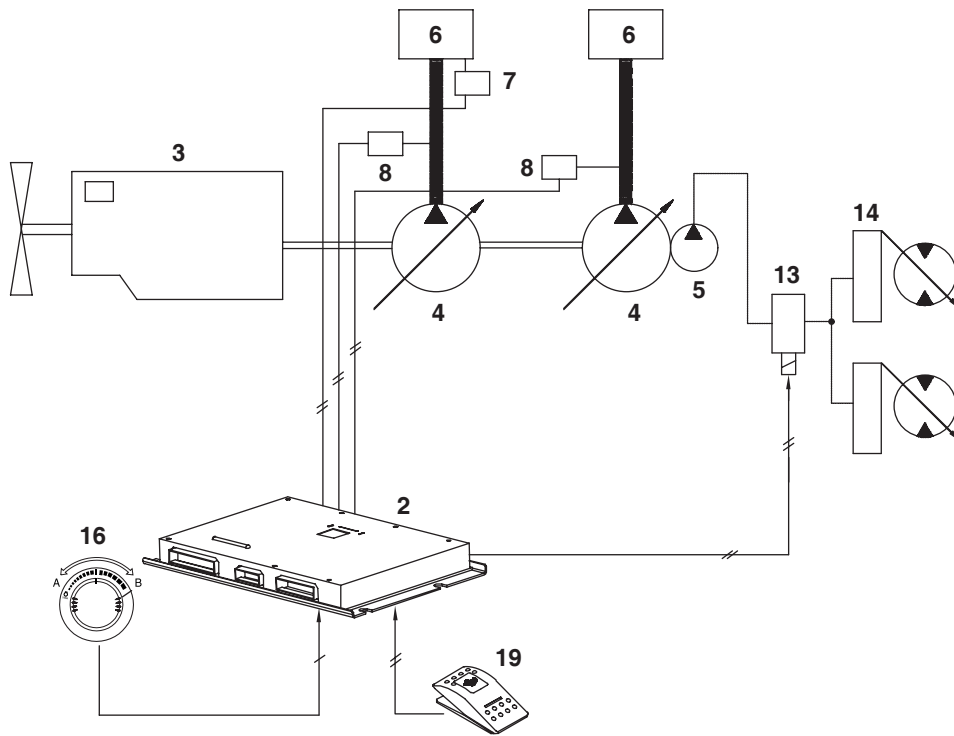

FG002110

Figure 65

Reference Number	Description
2	e-EPOS Controller
3	Engine
4	Main Pump
5	Aux Pump
6	Control Valve
7	Pressure Switch (Py Port)

Reference Number	Description
8	Pump Pressure Sensor
13	Solenoid Valve (High speed)
14	Travel Motor
16	Engine Control Dial
19	Selector Switch For Automatic Travel

If the automatic travel speed control switch is set to the "OFF" position, the travel motor will run in the I-speed (low speed) range. If the selector switch is set to the "I" position, the travel motor will run in the II-speed (high speed) range. If the selector switch is set to the "II" position, the e-EPOS controller will monitor the main pump discharge pressure and automatically select the "ON" - "OFF" status of the II - speed travel solenoid valve based on the travel load. The travel speed is changed between the I-speed and the II-speed mode.

The travel load is monitored by the two pressure sensors in the discharge lines of the front (upper) and rear (lower) pumps. When the travel load is high (pressure over 300 kg/cm<sup>2</sup> (4,300 psi) the solenoid valve is turned "OFF" and I-speed (low) is selected. In the case when the travel load is low (pressure under 160 kg/cm<sup>2</sup> (2,280 psi), the solenoid valve will be turned "ON" and the II-speed will be selected. But, if the engine speed control switch dial is set below approximately 1400 rpm, the travel speed will be set to I-speed mode.

# Automatic Travel Speed Control - Circuit Diagram

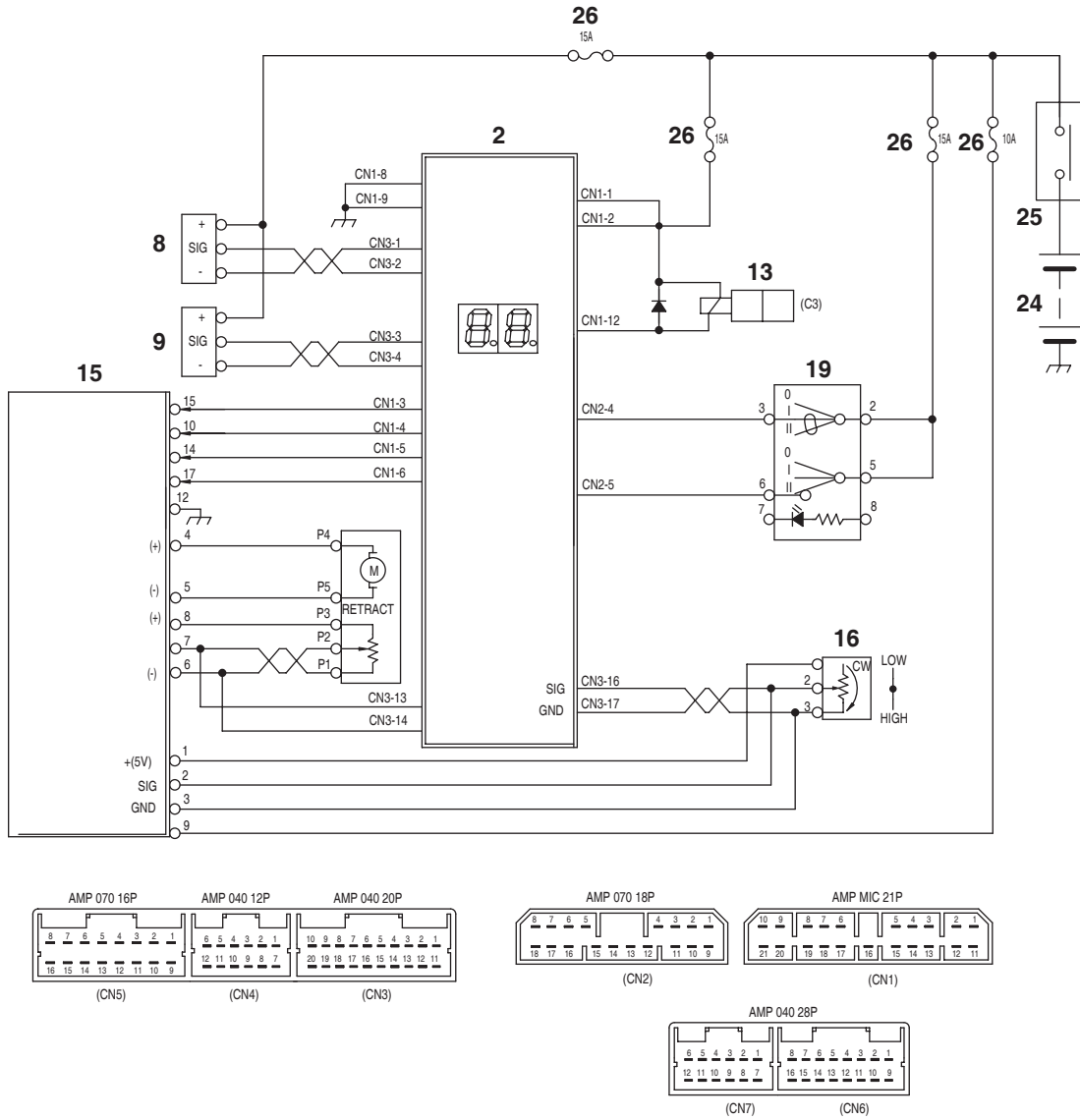

Figure 66

Reference Number	Description
2	e-EPOS Controller
8	Pressure Sensor (Front Pump)
9	Pressure Sensor (Rear Pump)
13	Solenoid Valve (High speed)
15	Engine Throttle Controller
16	Engine Control Dial

Reference Number	Description
19	Selector Switch For Automatic Travel
24	Battery
25	Battery Relay
26	Fuse

FG002111



# HOW TO ADJUST THE ENGINE CONTROL DEVICE

The engine speed adjustment is done following order.

1. High Idle speed adjustment
  - 1) Set to the H-mode by pushing the power mode switch after turning the start switch ON.
  - 2) Set the engine control dial to MAX position to make #01 motor cable pulled up initially.
  - 3) Adjust #01 motor cable in #32 bracket to make the engine governor lever reach the high stopper.
2. Low Idle speed adjustment
  - 1) Set the engine control dial to MIN position to make #01 motor cable lengthened maximum. At this time, the stroke of cable is approximately 37mm.
  - 2) Check whether the engine governor reaches to the low stopper and the cable hang down properly.
  - 3) If the lever doesn't reach the low stopper, move the #01 cable to the hole located one step down at the lever. In contrast, if the cable hangs down too much, move the #01 cable to the hole which is located on step up at the lever and repeat 1), 2)
  - 4) After doing above action, turn the adjustment nut of #01 motor cable 2/3~1 rotate and make it pull up 1~1,025mm and finish the adjustment.
3. Adjustment speed of automatic deceleration and standard mode
  - 1) Adjust the regulation speed with the following adjusting method (or opposite direction) after removing the rub bushing attached to the cover of engine throttle controller. (clockwise → increase speed, counterclockwise → decrease speed)
  - 2) Let the engine control dial be in max position, set up the select condition of power mode and auto idle following chart, respectively and set speed by adjusting screws of variable resistors (VR1, VR2). The established speed is written on the name plate attached on the cover of throttle controller.

Section	Variable Resistor	Dial position and set the mode			Regulated engine speed
		Dial	Power mode Switch	Auto Idle	
Set auto deceleration speed	VR1	MAX speed position	ON (Select the power mode)	ON	Written on the name plate of throttle controller
Set standard mode speed	VR2	MAX speed position	OFF (select the standard mode)	OFF	Written on the name plate of throttle controller

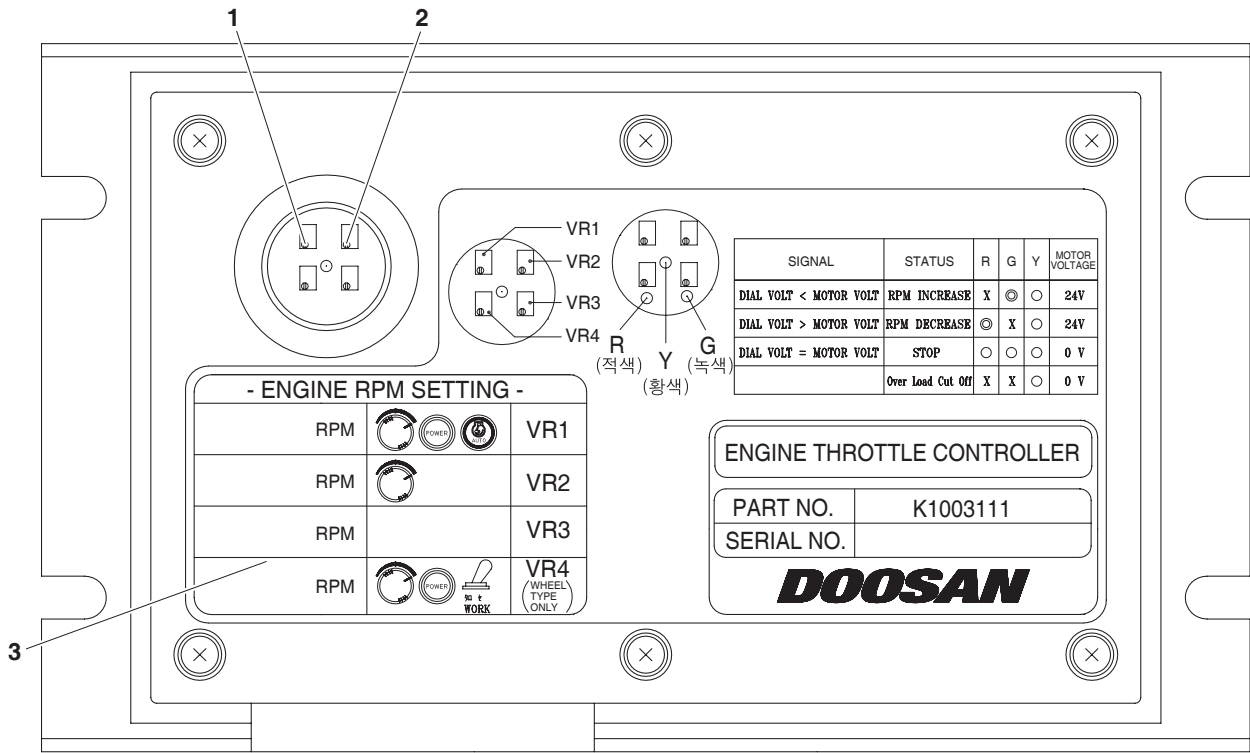

FG002112

Figure 67

Reference Number	Description
1	VR1 (set auto deceleration speed)
2	VR2 (set Power mode speed)

Reference Number	Description
3	Name plate

# ADJUST ENGINE SPEED

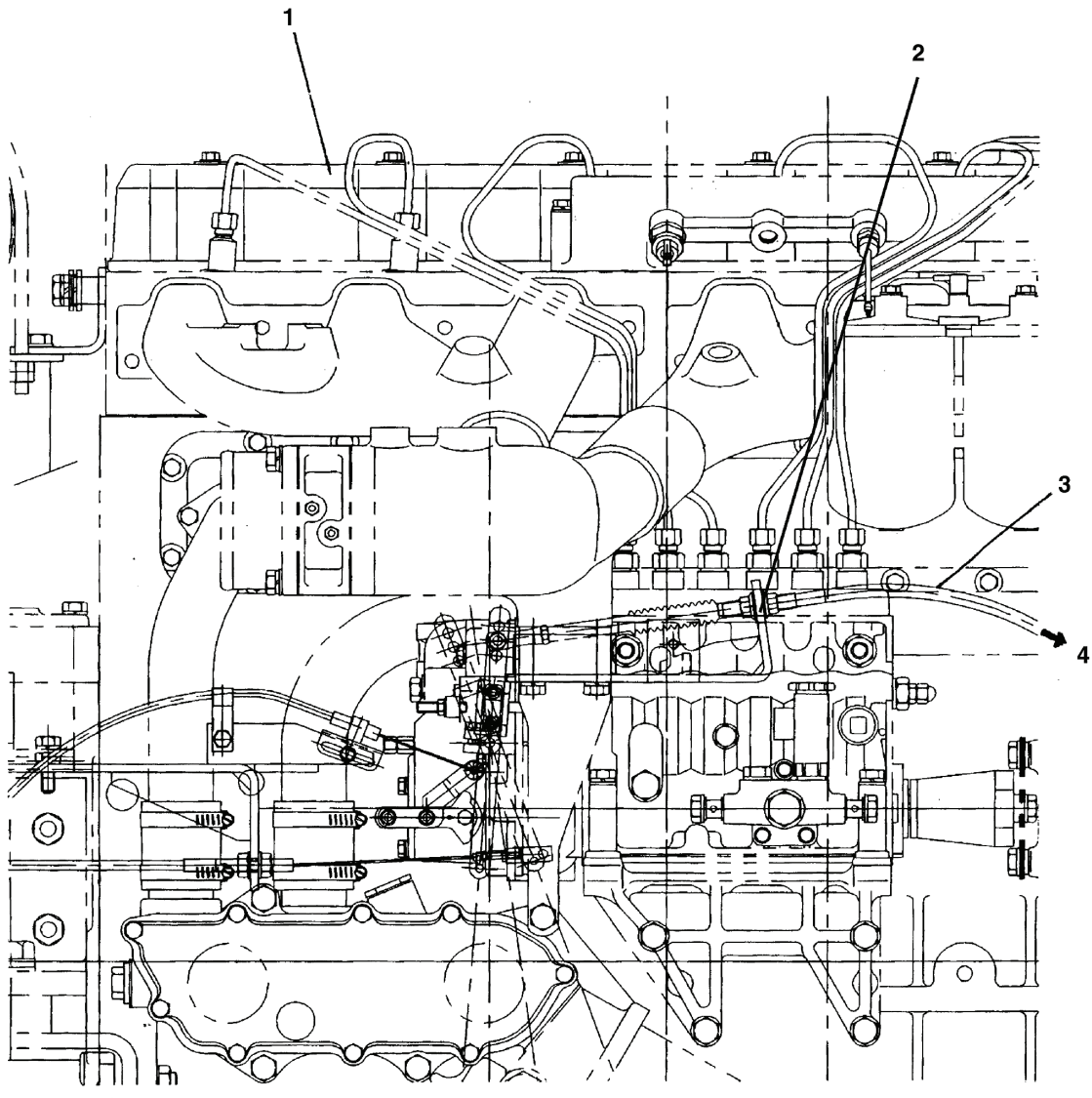

HBOC760S

Figure 68

Reference Number	Description
1	Engine Fuel Control Lever
2	Control Motor Cable Bracket

Reference Number	Description
3	Engine Speed Adjusting Cable
4	Engine Control Motor

# ENGINE THROTTLE CONTROLLER

When the rub cap on the upper part of controller is removed, three LED are shown in it.

LED works following chart with the condition of equipment (start switch is OFF).

Input signal of throttle controller	State	LED sign			Control motor terminal voltage
		Red	Green	Yellow	
Dial voltage < motor potentiometer voltage	Control motor is working on (RPM is increasing)	X	☉	O	Approximately + 24(V)
Dial voltage > motor potentiometer voltage	Control motor is working on (RPM is increasing)	☉	X	O	Approximately - 24(V)
Dial voltage = motor potentiometer voltage	Stop state	O	O	O	0 (V)
-	Motor overload (cut off current)	X	X	O	0 (V)
-	Error on controller voltage source (is low or no input)	X	X	X	0 (V)



## WARNING!

1. "☉" turn on brightly, "O" turn on, "X" turn off.
2. Measured terminal of motor voltage, 4(+), 5(-) terminal of throttle controller.
3. Yellow LED is used to show the Power on.
4. In motor overload current cut off mode, remove the cause of overload, and turn the start switch off and then on normal work should resume.

# SELF-DIAGNOSTIC FUNCTION

## e-EPOS Controller

The system operation status and malfunction codes can be checked through the display on top of the e-EPOS controller box the rear cover behind the operator's seat.

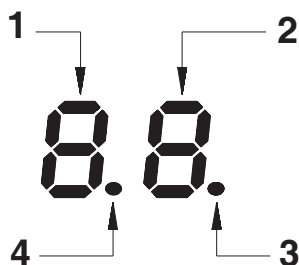

Figure 69

FG000588

Reference Number	Description
1	Upper Digit
2	Lower Digit
3	Engine Speed Monitor LED (Flash Interval Increases With Engine Speed.)

Reference Number	Description
4	Power Monitor (Stays "ON" While Power Is In Normal Range.)

### 1. Power Monitor

This LED is turned "OFF" when the input voltage to the e-EPOS controller is below  $18.5 \pm 1$  V or above  $32.5 \pm 1$  V. Stays "ON" while in normal range.

### 2. Engine Speed Monitor

This LED light flashes according to the engine speed. The flashing interval is proportional to the engine speed.

### 3. Normal Operation Display Readout

Mode Selection		Display Readout		Operation Status
		Upper Digit	Lower Digit	
Power Mode	Power Mode	9 HAOH340L	0 HAOH370L	Normal Operation Power Mode
	Standard Mode	7 HAOH350L	0 HAOH370L	Normal Operation Standard Mode

### 4. Communication Monitor

What are shown in the 7-SEGMENT LED are same as those in the Error Codes.

Error Code	Indication Code	Fault Location
V201	01	Communication error in instrument panel.
V202	02	Communication error in engine controller.

# AIR CONDITIONER SYSTEM

## Outline

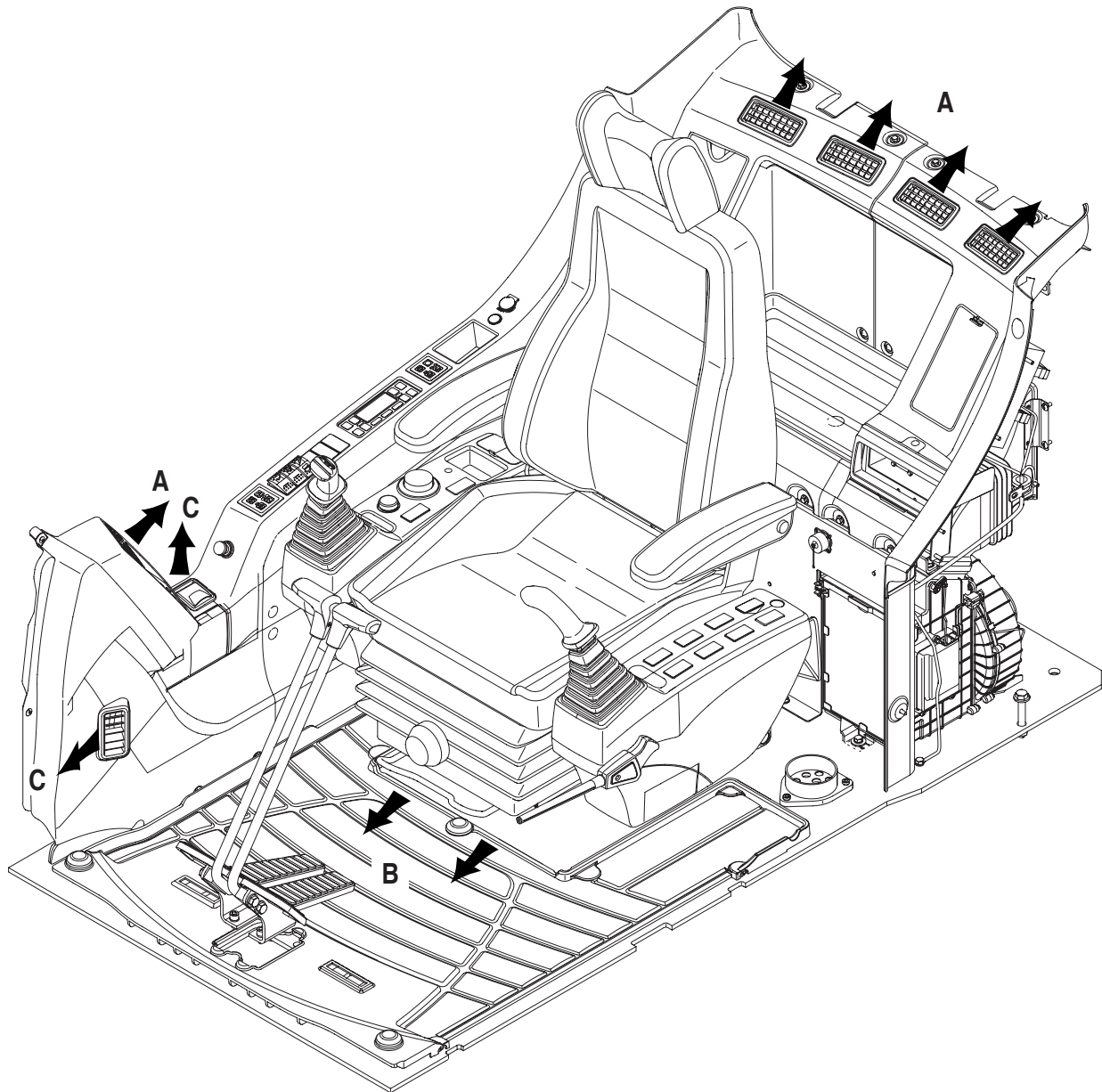

FG000784

**Figure 70**





Solid-type heater and air conditioner are installed in the cover behind the operator's seat.

Temperature of the operator's room is adjusted automatically to the temperature set by operator.

(Please refer to the Operation Manual for detailed full automatic control.

Vent mode selects the direction of discharged air.

## Outlets by vent modes

Modes					
Outlets	A	A+B	B	B+C	C

## Internal and External Filters

Internal and external air purification filters are installed for the operator's room.

Filters should be cleaned every 500 hours.

If machine operates in an excessively contaminated environment, filters should be cleaned more frequently and if necessary, replaced with new ones.

### How to Check Internal Air Filter

1. Press both levers on the left and right side at the top of the filter installed at the rear of the operator's seat.

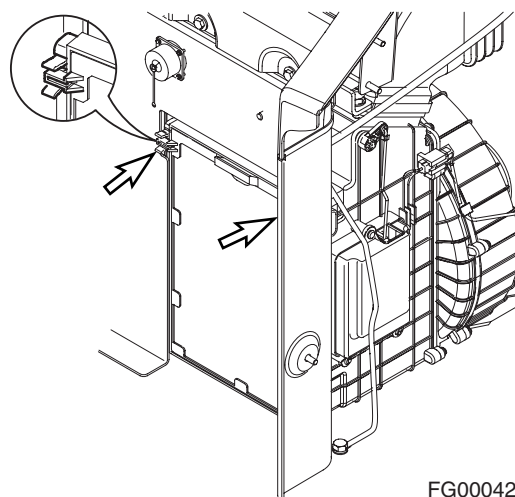

Figure 71

FG000422

### How to Check External Air Filter

1. Open the door at the left side of machine and loosen four marked bolts to remove the cover (1, Figure 72).

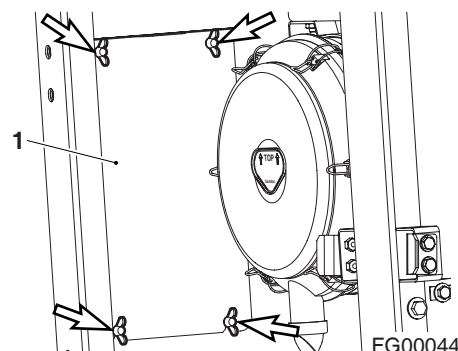
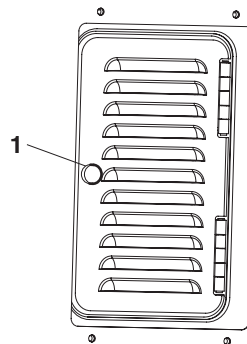

Figure 72

FG000440

2. Turn marked knobs (1, Figure 73) at the rear side of the cabin to open the cover.



FG000441

**Figure 73**

3. Remove the filter attached to the cover and clean the contaminated filter using compressed air.
4. Close the cover, replace the knobs, and secure the cover to the support with butterfly bolts.

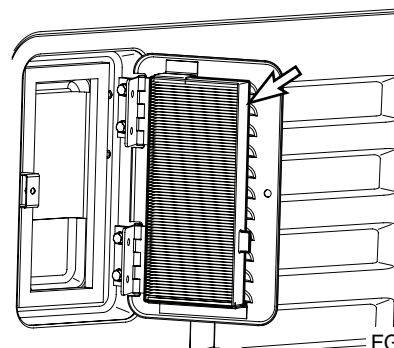

FG000342

**Figure 74**

# Air-Conditioning System Layout

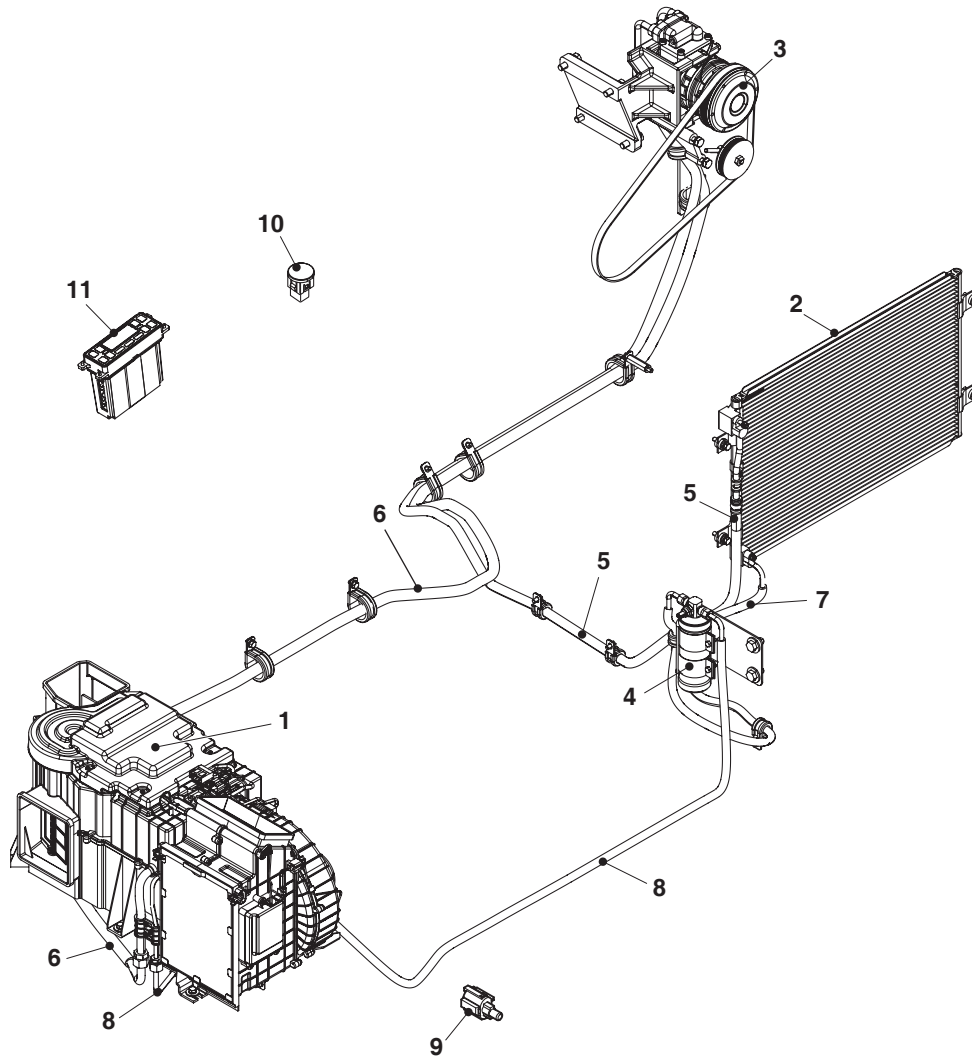

FG001464

Figure 75

Reference Number	Description
1	Air Conditioner/heater Unit
2	Condenser
3	Compressor
4	Receiver Dryer
5	Discharge Hose
6	Suction Hose

Reference Number	Description
7	Liquid Hose (1)
8	Liquid Hose (2)
9	Ambient Temperature Sensor
10	Sun Sensor
11	Control Panel

# Air Conditioner/heater Circuit Diagram

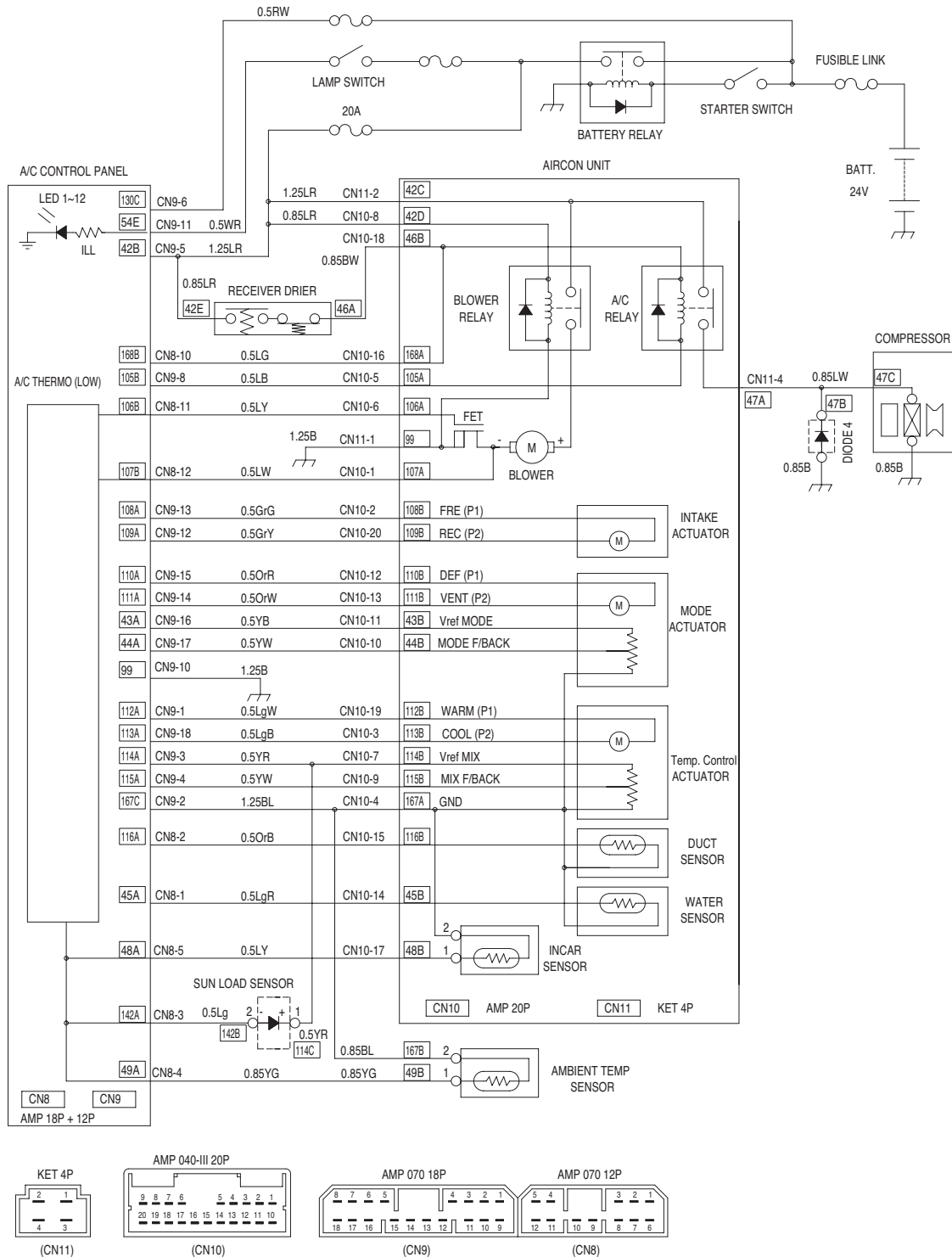
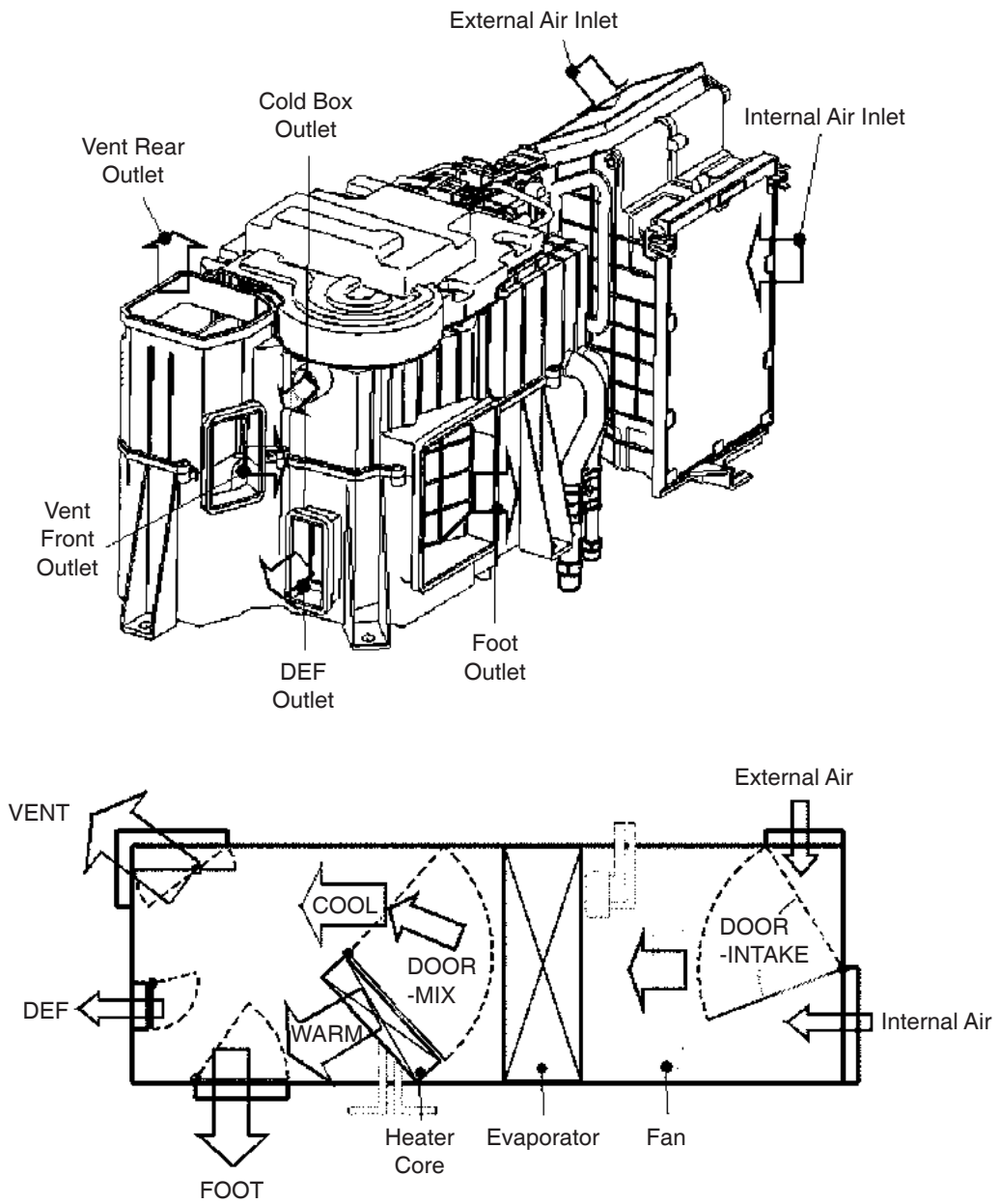

Figure 76

FG001463

# Air Conditioner/heater Unit

## Air Flow Diagram



FG001359

Figure 77

## Door Open by Vent Modes

Door	Mode				
	Vent	Bi-level	Foot	Def/foot	Def
Vent	100	60	0	0	0
Foot	0	40	100	80	60
Def	0	0	0	20	40

## Main Components

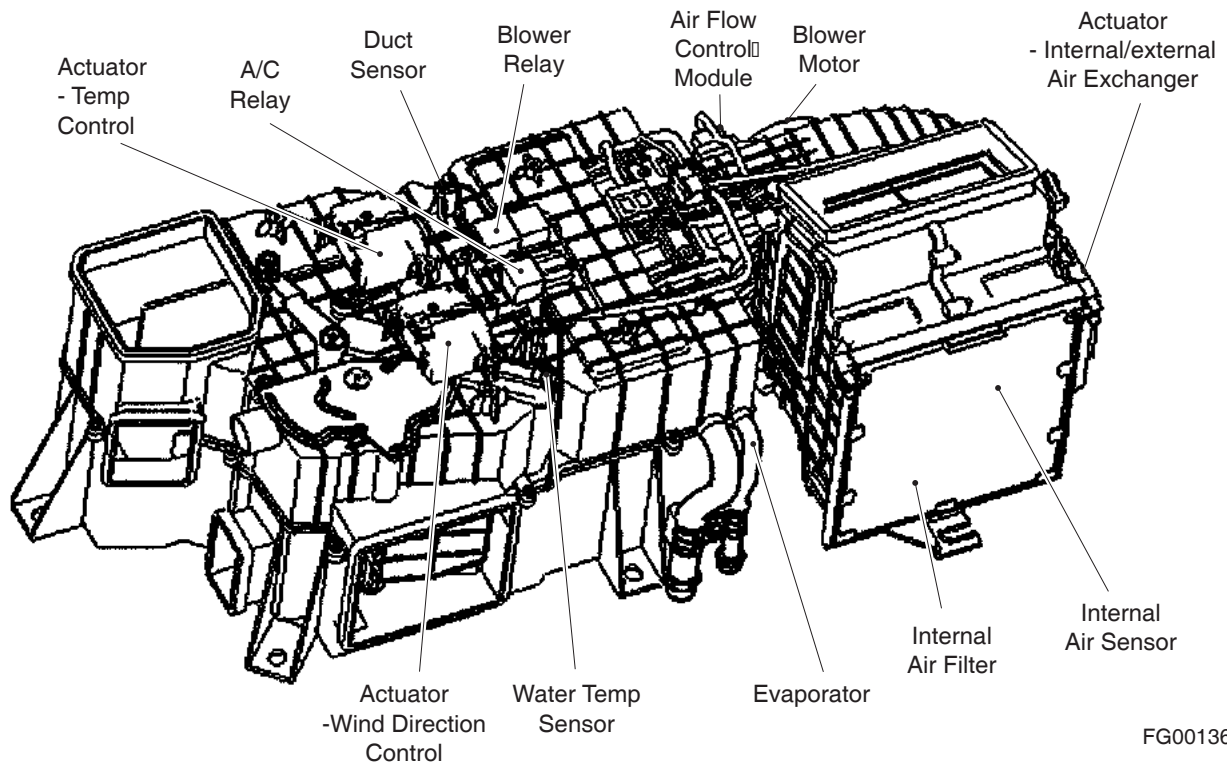

Figure 78

**Actuator - Wind Direction Control**

Change of discharged air flow according to selected wind direction mode

Change of wind direction: Direction changes in the order of VENT→ BI-LEVEL → FOOT → FOOT/DEF → VENT.

**Actuator - Temperature Control**

Change of discharged air temperature by controlling the position of temperature control door.

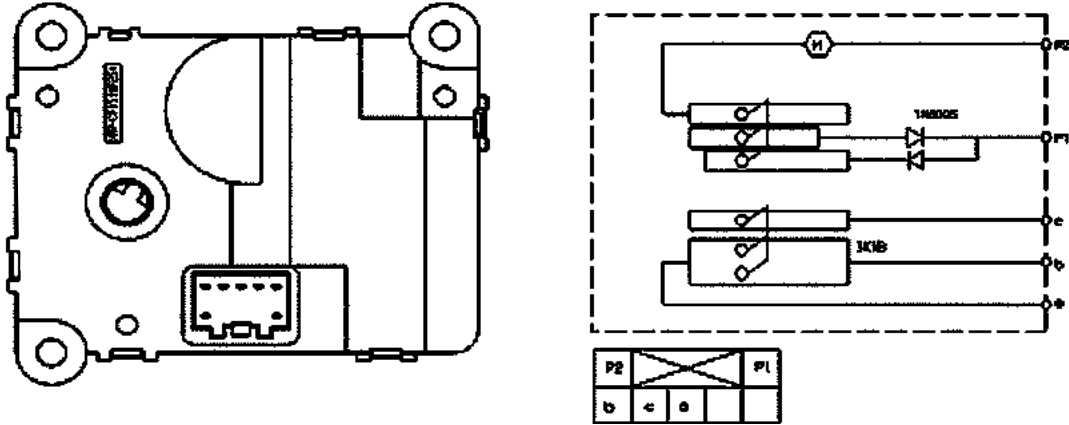

FG001361

Figure 79

**Actuator - Wind Direction Control**

Wind Direction Mode	Output Terminal	Voltage
Vent	c(+): CN10-10 b(-): CN10-4	0.5 ±0.2V
Bi-level		1.3 ±0.2V
Foot		2.45 ±0.2V
Foot/def		3.5 ±0.2V
Def		4.5 ±0.2V

**Actuator - Temperature Control**

Set Temperature	Output Terminal	Voltage
Max cooling	c(+): CN10-9	Below 0.4V
Max heating	b(-): CN10-4	Above 4.5V

## Actuator - Internal/external Air Exchange

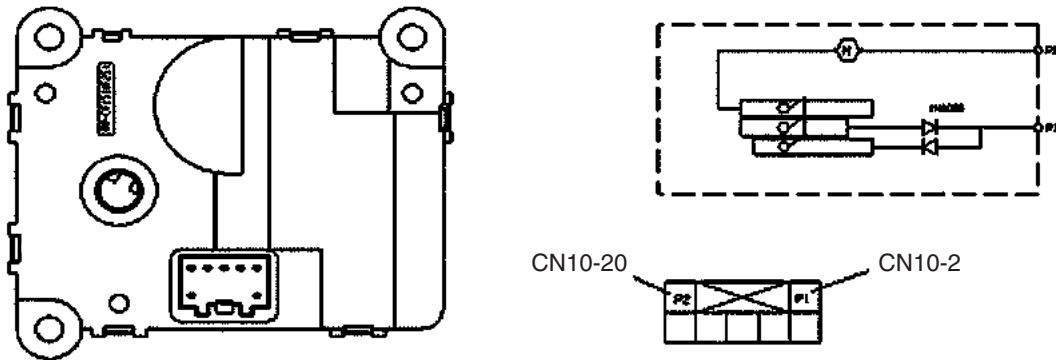

FG001055

Figure 80

Mode	Output Terminal	Output
Intake	P1(+), P2(-)	Moving of exchange door by selecting intake.
Recirculate	P1(-), P2(+)	Moving of exchange door by selecting recirculate.

## Air Flow Control Module

Air flow is controlled through the control of voltage between GATE and SOURCE.

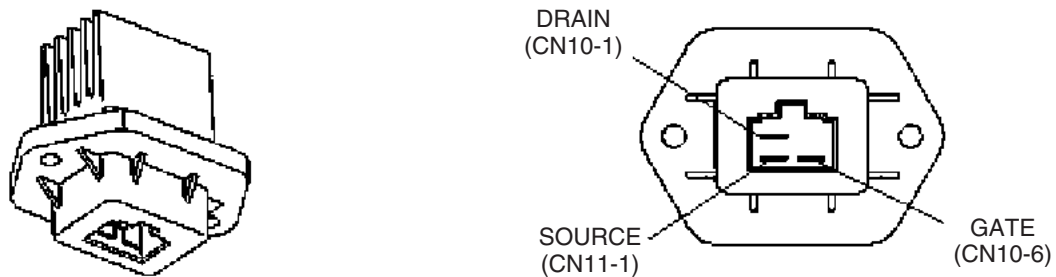

FG001056

Figure 81

Air flow	Output Terminal		Output
1st	CN11-2	CN10-1	10 ±0.5V
2nd			12.5 ±0.5V
3rd			15 ±0.5V
4th			17.5 ±0.5V
5th			20.0 ±0.5V
6th			22.0 ±0.5V
7th			More than 25V

Input voltage is 27.5V.

The air flow is based on manual set.

**Relay - Blower:** Power is supplied to the blower motor when the system is turned "ON."

Specifications	
Rated voltage	24V
Rated current	20A

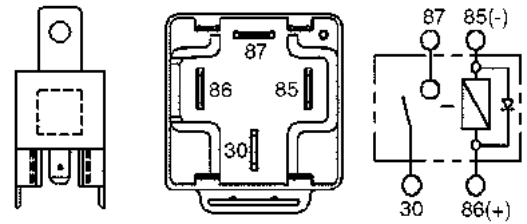

Figure 82

FG001057

**Relay - A/C:** Power is supplied to the magnetic clutch of the compressor.

Specifications	
Rated voltage	24V
Rated current	10A

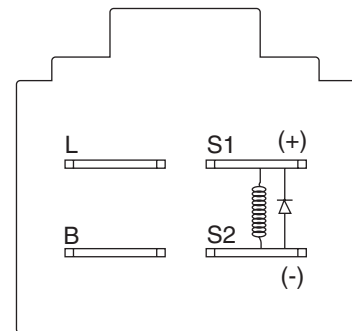

Figure 83

FG001058

**Duct Sensor:** It is inserted in the core of the evaporator to prevent freezing of the evaporator.

The sensor consist of negative characteristic thermistor that resistant value increases and decreases when the temperature rises and falls, respectively.

Temperature (°C)	Resistance (KΩ)
0	11.36 ±0.1
2	10.39 ±0.2
2.5	10.17 ±0.2
3	9.95 ±0.2
3.5	9.73 ±0.2
4	9.52 ±0.2
5	9.12 ±0.2
10	7.36 ±0.15
25	4.02 ±0.08
30	3.33 ±0.07

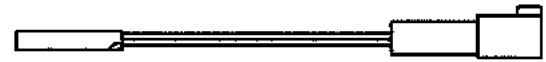

Figure 84

FG001059

**Water Temperature Sensor:** It senses the temperature of coolant water in the heater core.

Temperature (°C)	Resistance (KΩ)
-10	55.8 ±1.7
0	32.9 ±0.9
15	15.76 ±0.5
25	10.0 ±0.3
35	6.5 ±0.2



FG001060

Figure 85

**Internal Air Temperature Sensor:** Built in the internal air filter, it senses the internal temperature.

Temperature (°C)	Resistance (KΩ)
-15	218.2 ±7.5
0	97.83 ±0.9
15	47.12 ±0.7
25	30.0 ±0.36
35	19.60 ±0.3

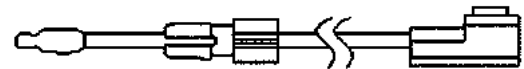

FG001061

Figure 86

## Ambient Air Temperature Sensor

Built at the bottom of the cockpit, it senses the temperature of external air.

Temperature (°C)	Resistance (KΩ)
-10	163 ±4.9
0	96.9 ±2.9
10	59.4 ±1.8
20	37.4 ±1.1
25	30 ±0.9
30	24.2 ±0.7

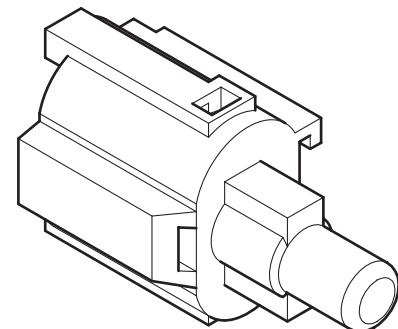

FG001064

Figure 87

## Sun Sensor

Built beside the socket of spare power, it senses the quantity of the sun radiation to optimize discharge temperature and air flow as set by operator.

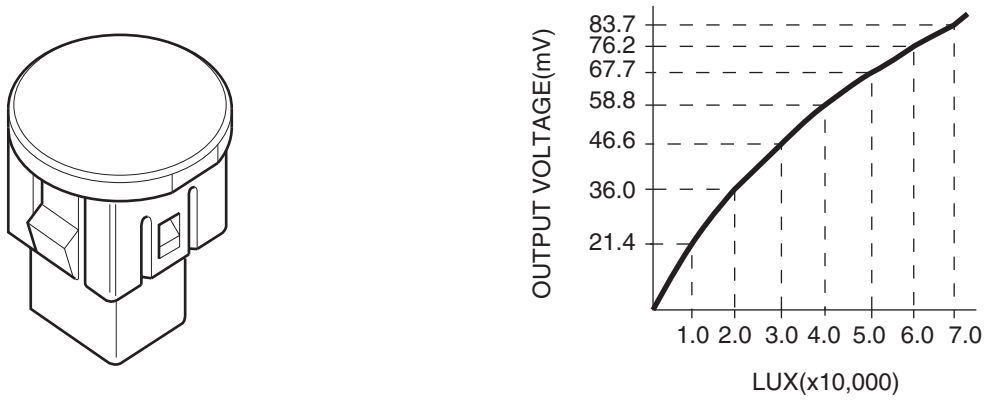

Figure 88

FG001062

## Control Panel

### Appearance and Terminal Arrangement

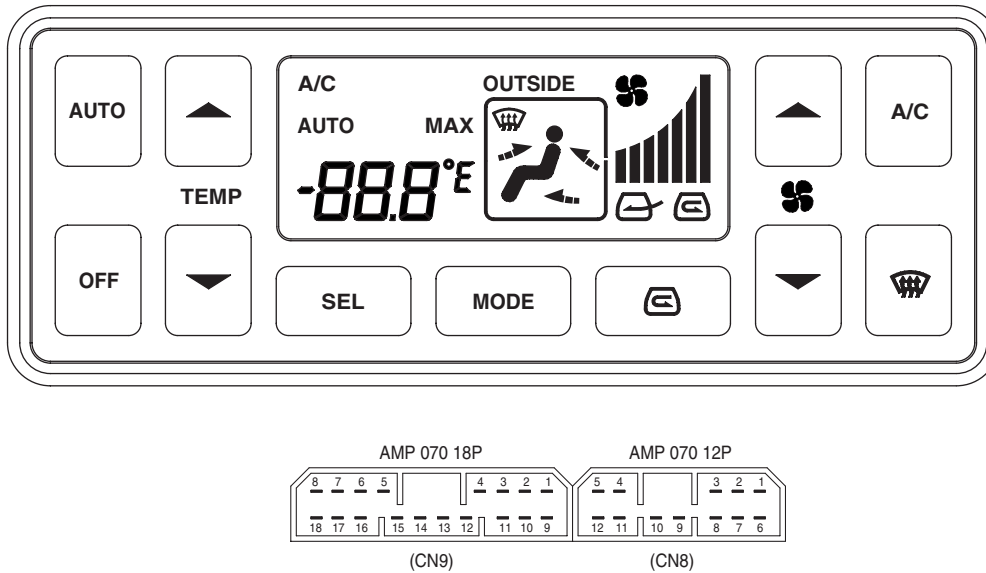

Figure 89

FG001063

Refer to "Air Conditioner and Heater" of operation manual.

## Terminal Terms

CN	Term No.	Terms
CN9	1	Temperature control (warm)
	2	Sensor ground
	3	Temperature control Power (5V)
	4	Mix feedback
	5	Power (KEY "ON")
	6	Back-up
	7	-
	8	A/C output (LOW)
	9	-
	10	Ground
	11	Illumination
	12	Intake/Recirculate (Recirculate)
	13	Intake/Recirculate (Intake)
	14	Wind direction control (VENT)
	15	Wind direction control (DEF.)
	16	Wind direction control Power (5V)
	17	Wind direction control (feedback)
	18	Temperature control (cool)

CN	Term No.	Terms
CN8	1	Water temperature sensor
	2	Duct sensor
	3	Sun sensor
	4	Ambient air temperature sensor
	5	Internal air temperature sensor
	6	-
	7	-
	8	-
	9	-
	10	D.P.S CHECK
	11	Air flow module (gate)
	12	Blower motor (feedback)

## Control Logic

Categories	Inputs	System Operation																		
AUTO	Set temperature Internal air temperature sensor Ambient air temperature sensor Water temperature sensor Sun sensor	<ol style="list-style-type: none"> <li>1. Automatically adjust room temperature as set and then next items. Temperature, Wind direction, Recirculate/Intake, Air flow, Compressor</li> <li>2. Auto mode is released when manually setting any switch except, Temperature Control switch in Auto mode.</li> <li>3. Upon the releasing of Auto mode, all of functions except selected switch are controlled automatically.</li> </ol>																		
Sensor compensation	Set temperature Internal air temperature sensor Ambient air temperature sensor Water temperature sensor	<ol style="list-style-type: none"> <li>1. In case of sensor failure, following defaults are applied:            Internal air temperature sensor: 25°C, Ambient air temperature sensor: 25°C, Duct sensor: -2°C            Temperature control actuator:            - Set Temperature 17 - 24.5°C: Max cooling, Set Temperature 25 - 32°C: Max heating            Wind direction mode actuator            - VENT: VENT fix, modes other than VENT: Fixed to DEF            * Sun sensor is not compensated.</li> </ol>																		
Max cooling/heating control	Auto Setting	<ol style="list-style-type: none"> <li>1. Set Temperature 32°C: Max heating</li> <li>2. Set Temperature 17°C: Max cooling</li> </ol> <table border="1" data-bbox="716 1005 1395 1377"> <thead> <tr> <th></th> <th>Max Cooling (17 °C)</th> <th>Max Heating (32 °C)</th> </tr> </thead> <tbody> <tr> <td>Temp Control Actuator</td> <td>FULL COOL</td> <td>FULL HOT</td> </tr> <tr> <td>Air Flow</td> <td>MAX HI</td> <td>AUTO HI</td> </tr> <tr> <td>Compressor</td> <td>Forced ON</td> <td>OFF</td> </tr> <tr> <td>Intake/Recircle</td> <td>Recircle</td> <td>Intake</td> </tr> <tr> <td>Wind Direction Mode</td> <td>VENT</td> <td>FOOT</td> </tr> </tbody> </table> <p>* Max cooling/heating control is possible only in Auto mode.</p>		Max Cooling (17 °C)	Max Heating (32 °C)	Temp Control Actuator	FULL COOL	FULL HOT	Air Flow	MAX HI	AUTO HI	Compressor	Forced ON	OFF	Intake/Recircle	Recircle	Intake	Wind Direction Mode	VENT	FOOT
	Max Cooling (17 °C)	Max Heating (32 °C)																		
Temp Control Actuator	FULL COOL	FULL HOT																		
Air Flow	MAX HI	AUTO HI																		
Compressor	Forced ON	OFF																		
Intake/Recircle	Recircle	Intake																		
Wind Direction Mode	VENT	FOOT																		

Categories	Inputs	System Operation
Starting Control of Cooling	Auto mode Duct sensor	<ol style="list-style-type: none"> <li>1. Prevention of discharge of hot air before discharge temperature drops enough in hot summer weather</li> <li>2. Start conditions (AND condition)               <ol style="list-style-type: none"> <li>(1) A/C on (AUTO or manual)</li> <li>(2) Temperature sensed by the duct sensor is above 30°C</li> <li>(3) Air flow: Auto mode</li> </ol> </li> <li>3. One time control in the cycle of engine OFF → engine run</li> <li>4. Initial cooling control is executed when the Auto switch is "ON" in the manual status (A/C "OFF" and manual control of air flow) in 5 seconds after engine run.</li> <li>5. Initial cooling control should be before max cooling.</li> <li>6. Release condition (OR condition)               <ol style="list-style-type: none"> <li>(1) A/C "OFF"</li> <li>(2) Air flow: Manual control</li> <li>(3) Release is possible with the "OFF" switch but not allowed within 12 seconds (after Start "ON") while the system is off using the "OFF" switch and during the time of initial cooling control.</li> </ol> </li> </ol>

Categories	Inputs	System Operation
Starting control of heating (1)	Water temperature sensor Internal air temperature sensor Auto mode Set Temperature	<ol style="list-style-type: none"> <li>1. Start condition (AND condition) <ul style="list-style-type: none"> <li>(1) When wind direction mode is one of the following modes in the Auto or manual control mode <ul style="list-style-type: none"> <li>- BI-LEVEL, FOOT or FOOT/DEF</li> </ul> </li> <li>(2) The Water temperature sensor is stable and the water temperature &lt; 73°C</li> <li>(3) Air flow: Auto mode</li> <li>(4) Set temperature &gt; Internal air temperature + 3°C</li> </ul> <p>* Air flow falls gradually up to 12 seconds when operation released.</p> </li> <li>2. One time control in the cycle of engine OFF → engine run</li> <li>3. Initial heating control should be before max heating.</li> <li>4. Air flow is controlled only when the wind direction is in the manual mode and BI-LEVEL, FOOT, or FOOT/DEF is set.</li> <li>5. Control through the water temperature sensor for start.</li> <li>6. Starting control of heating (2) starts in case of fault of the water temperature sensor during controlling.</li> <li>7. Operation release (OR condition) <ul style="list-style-type: none"> <li>(1) Only air flow is released if it is selected manually.</li> <li>(2) When handling the wind direction mode switch, only wind direction is released but the air flow control is performed only for the remaining period of the starting control of heater.</li> <li>(3) When Max Cooling (17°C) is selected.</li> <li>(4) Water temperature sensor &gt; 73°C.</li> </ul> </li> </ol>

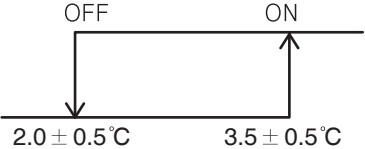
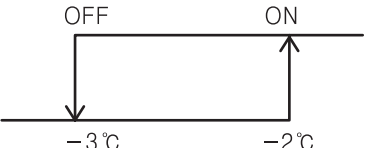
Categories	Inputs	System Operation
Starting control of heating (2)	Water temperature sensor Ambient air temperature sensor Internal air temperature sensor Auto mode	<ol style="list-style-type: none"> <li>1. Entry condition (AND condition)               <ol style="list-style-type: none"> <li>(1) Auto Mode</li> <li>(2) Ambient air temperature &lt; 5°C and difference between ambient and internal air temperature &gt; 5°C</li> <li>(3) Failure of water temperature sensor</li> </ol> </li> <li>2. Only one time of engine OFF → engine run</li> <li>3. Starting control of heating is before max heating.</li> <li>4. Operation release (OR condition)               <ol style="list-style-type: none"> <li>(1) Air flow: Manual selection</li> <li>(2) When handling the wind direction mode switch, only wind direction is released but the air flow control is performed only for the remaining period of the starting control of heater.</li> <li>(3) Difference between internal and ambient air temperature &gt; 15°C</li> <li>(4) When Max Cooling (17°C) is selected.</li> </ol> </li> <li>5. Exceptional case                Starting control of heating is performed only once during the remaining period if the entry condition is satisfied within the starting control period that is the accumulation of initial start times.                 (Inclusive of Auto mode "ON" case within the period of starting control of heater.)                 * Air flow should be reduced slowly for up to 12 seconds in case of exceptional entry case.             </li> </ol>
Compressor control	Duct sensor	<ol style="list-style-type: none"> <li>1. Function: Magnetic clutch of compressor is turned "ON/OFF" depending on temperature of the duct sensor to prevent the freezing of the evaporator with A/C being "ON."</li> <li>2. Control pattern.</li> </ol> 
	External temperature sensor	<ol style="list-style-type: none"> <li>1. Function: Prevention of compressor in winter.</li> <li>2. Control pattern.</li> </ol>  <p>*Only for Auto mode.</p>

## Self Diagnosis

How to start self diagnosis

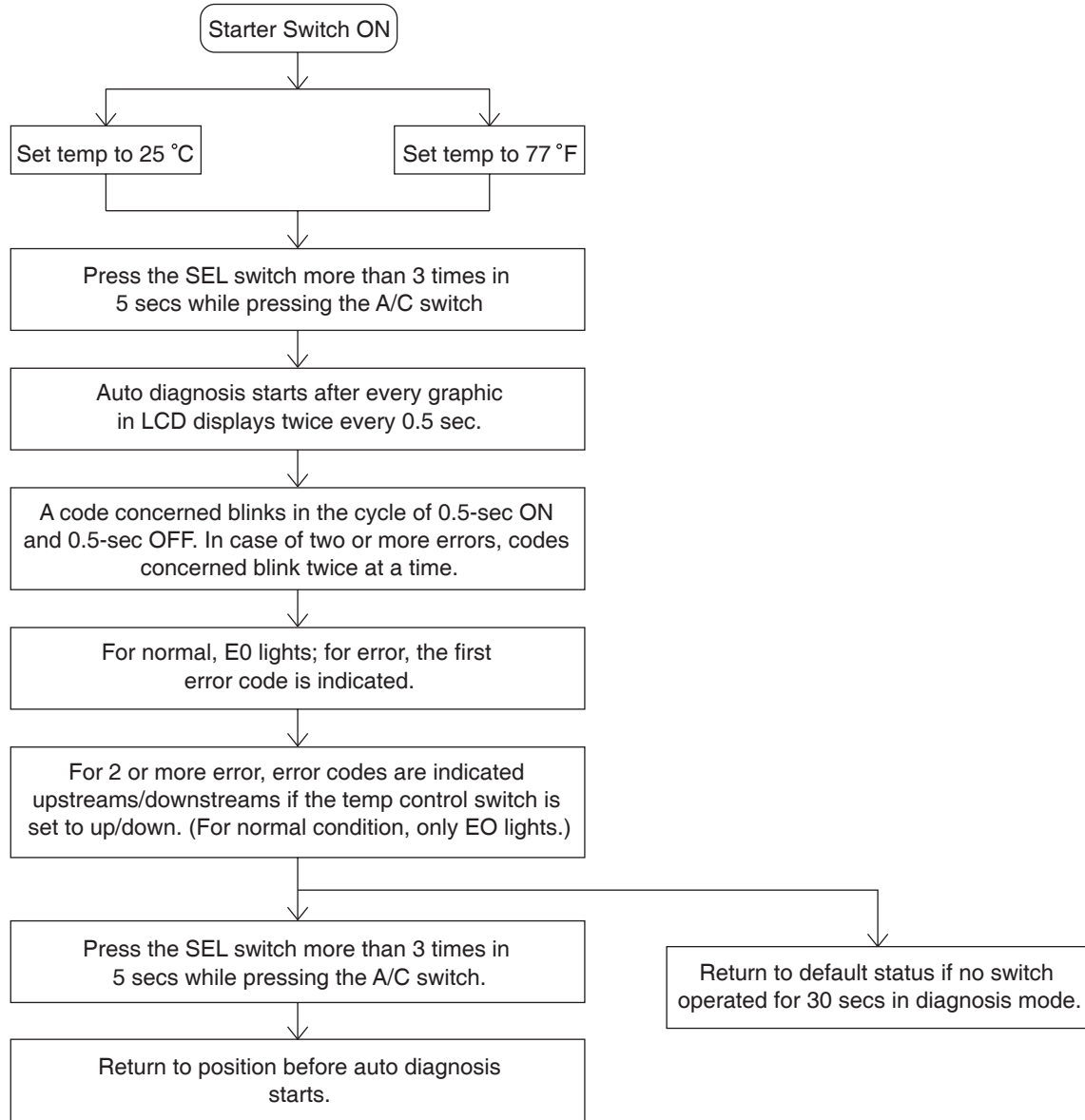

Figure 90

FG001367

## Error codes

Code	Description
E0	Normal
E1	Internal air temperature sensor short
E2	Internal air temperature sensor open
E3	Ambient air temperature sensor short
E4	Ambient air temperature sensor open
E5	Duct sensor short
E6	Duct sensor open
E7	Sun sensor short
E8	Sun sensor open
E9	Water temperature sensor short
E10	Water temperature sensor open
E11	D.P.S open
E12	Position error of wind direction actuator
E13	Position error of temperature control actuator

**NOTE:** *The position error means that it fails to move to designated place in 40 seconds.*

*Sun sensor displays E8 in case of no sunlight.*

*2 and more fails: Codes concerned blinks twice at a time.*

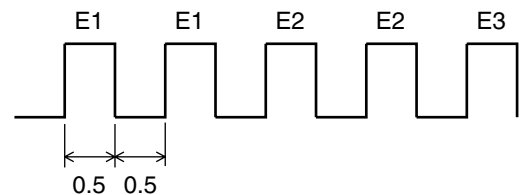

FG001067

**Figure 91**

## Ambient Temperature Display

Selection of both the SEL and MODE switch for more than 3 seconds indicates the ambient temperature in the set temperature display department.

- Range of temperature display: -40 - +60°C

**NOTE:** *Display of ambient temperature may be released in the same way for its entry way.*

*It returns automatically to default mode 5 seconds after entering the ambient air temperature display mode.*

# Compressor

Categories	Specifications
Output	155.3 cc/rev
Oil Level	120 cc (ND-OIL8)
Refrigerant	R134a
Rated Voltage	24V
Relief Valve	Open: 35 - 42.2 kg/cm <sup>2</sup> G Close: 28.1 kg/cm <sup>2</sup> G

Compressor sucks in refrigerant which evaporates completely in the evaporator and discharges it to the condenser.

Refrigerant undergoes repeated status change in the order of liquid, gas, and liquid in the freezing cycle, and the compressor makes evaporated refrigerant a high temperature and high-pressured gas to freeze it in the condenser.

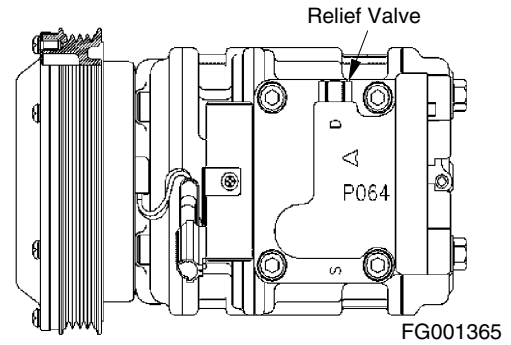

Figure 92

# Receiver Dryer

The receiver dryer reserves refrigerant enough to ensure smooth freezing cycle responding immediately to the change of level in the freezing cycle.

As liquid refrigerant from the condenser may contain refrigerant gas with bubbles whose presence in the expansion valve decreases the freezing power excessively, it separates liquid and gas and sends liquid only to the expansion valve.

Water in refrigerant shall be eliminated with dryer and through filter.

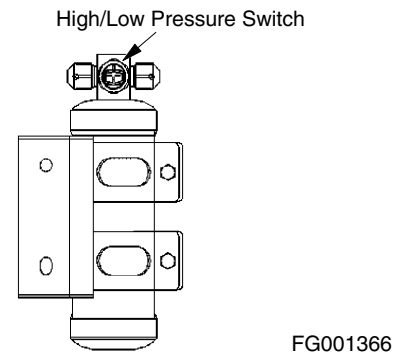

Figure 93

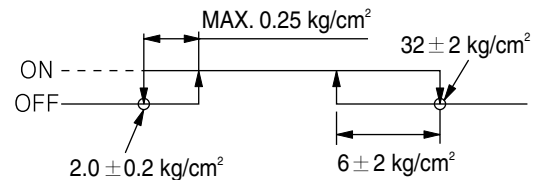

Figure 94

## Volume of refrigerant by model

Model	Volume of Refrigerant
DX300LC	800 ±20 grams
DX340LC	800 ±20 grams

# WIPER SYSTEM

## Wiper Circuit

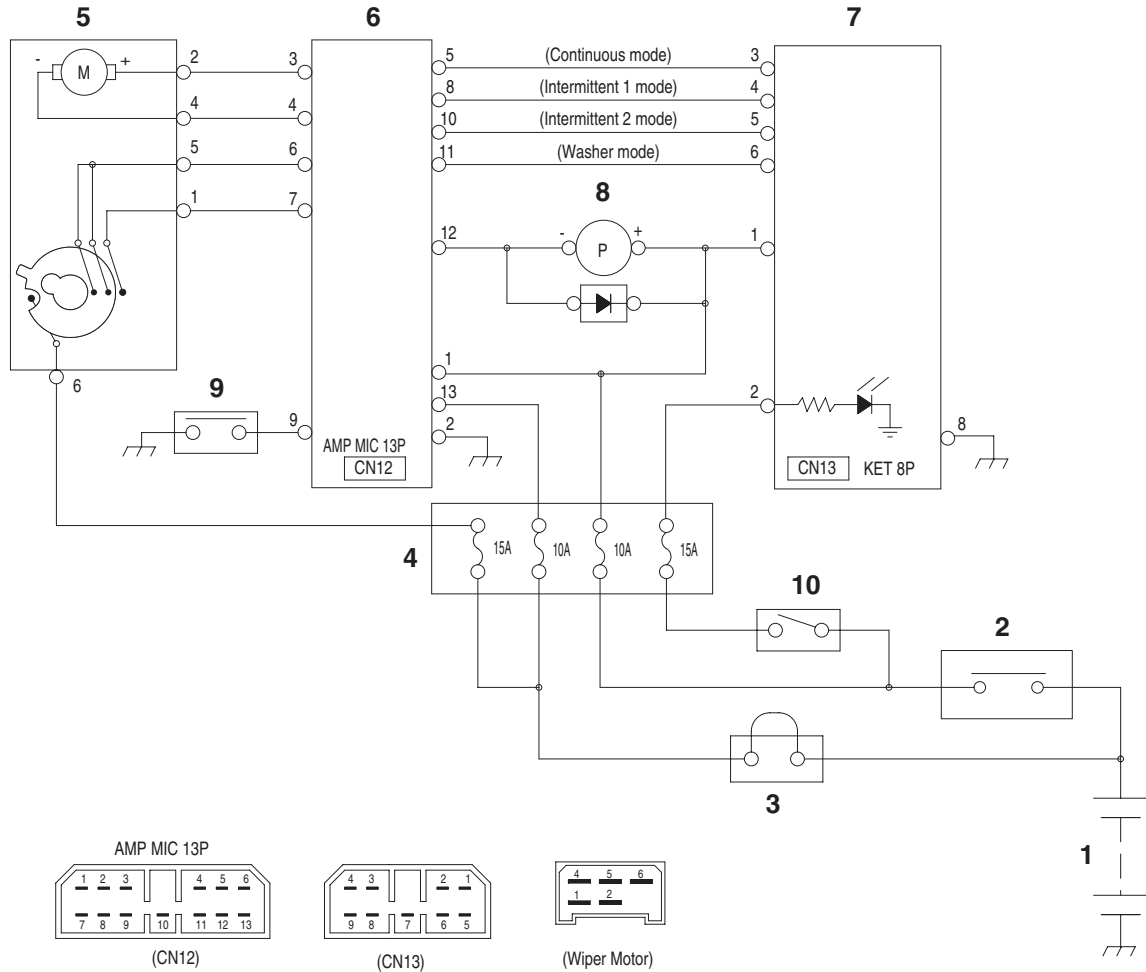

FG000589

Figure 95

Reference Number	Description
1	Battery
2	Battery Relay
3	Fusible Link
4	Fuse Box
5	Wiper Motor

Reference Number	Description
6	Wiper Controller
7	Wiper Switch Panel
8	Window Washer
9	Wiper Cutoff Switch
10	Light Switch

# Wiper operation

## Continuous operation

### - Operation of wiper motor

Pressing the successive operation switch on the wiper switch panel (7) changes the voltage of the "5" terminal of the wiper controller (6) from HIGH (about  $5.5 \pm 0.5V$ ) to LOW ( $0+0.5V$ ) and also current flows via the "3" terminal of the wiper controller (6) → the "2" and "4" terminals of the wiper motor (5) → the "4" terminal of the wiper controller (6) to run the wiper motor (5) continuously.

### - Stop of wiper motor

Pressing again the successive operation switch on the wiper switch panel (7) changes the voltage of the "5" terminal of the wiper controller (6) from LOW ( $0+0.5V$ ) to HIGH (about  $5.5 \pm 0.5V$ ). As the "5" and "6" terminals of the wiper motor are connected still that power is supplied to the "6" terminal of the wiper controller (6),

However, the controller (6) runs the wiper motor continuously and then rotates the motor reversely by "letting current flow via the "4" terminal of the wiper controller (6) → the "2" and "4" terminals of the wiper motor (5) → the "3" terminal of the wiper controller (6) when the "1" and "6" terminals of the wiper motor (5) are connected and thus power voltage is supplied to the "7" terminal of the wiper controller (6).

The Wiper motor (5) stops reverse revolution when the contact of a cam switch connected to the "6" terminal of the wiper motor (5) moves to an insulation area of the cam plate to disconnect the "5" and "6" terminals of the wiper motor (5).

When the wiper motor (5) stops, arm and blade connected to it move to the stop positions of the right pole in the cabin.

## Intermittent operation

### - Intermittent 1st (3-second)

Pressing once the Intermittent switch in the switch panel (7) changes voltage of the "8" terminal in the wiper controller (6) from HIGH (about  $5.5 \pm 0.5V$ ) to LOW ( $0+0.5V$ ) and current flows through the "3" terminal in the wiper controller (6) → the "2" and "4" terminals in the wiper motor (5) → the "4" terminal in the wiper controller (6) to start the cycle that wiper stops 3 seconds after every operation.

### - Intermittent 2nd (6-second)

Pressing twice the Intermittent switch in the switch panel (7) changes voltage of the "10" terminal in the wiper controller (6) from HIGH (about  $5.5 \pm 0.5V$ ) to LOW ( $0+0.5V$ ) and current flows through the "3" terminal in the wiper controller (6) → the "2" and "4" terminals in the wiper motor (5) → the "4" terminal in the wiper controller (6) to start the cycle that wiper stops 6 seconds after every operation.

**- Stopping the intermittent action**

Pressing three times the Intermittent switch in the switch panel (7) while the wiper is operating stops the action of the wiper motor.

**NOTE:** *The wiper system does not work when the wiper cutoff switch (9) is "ON."*

# LIGHTING SYSTEM

## Lighting System Circuit Diagram

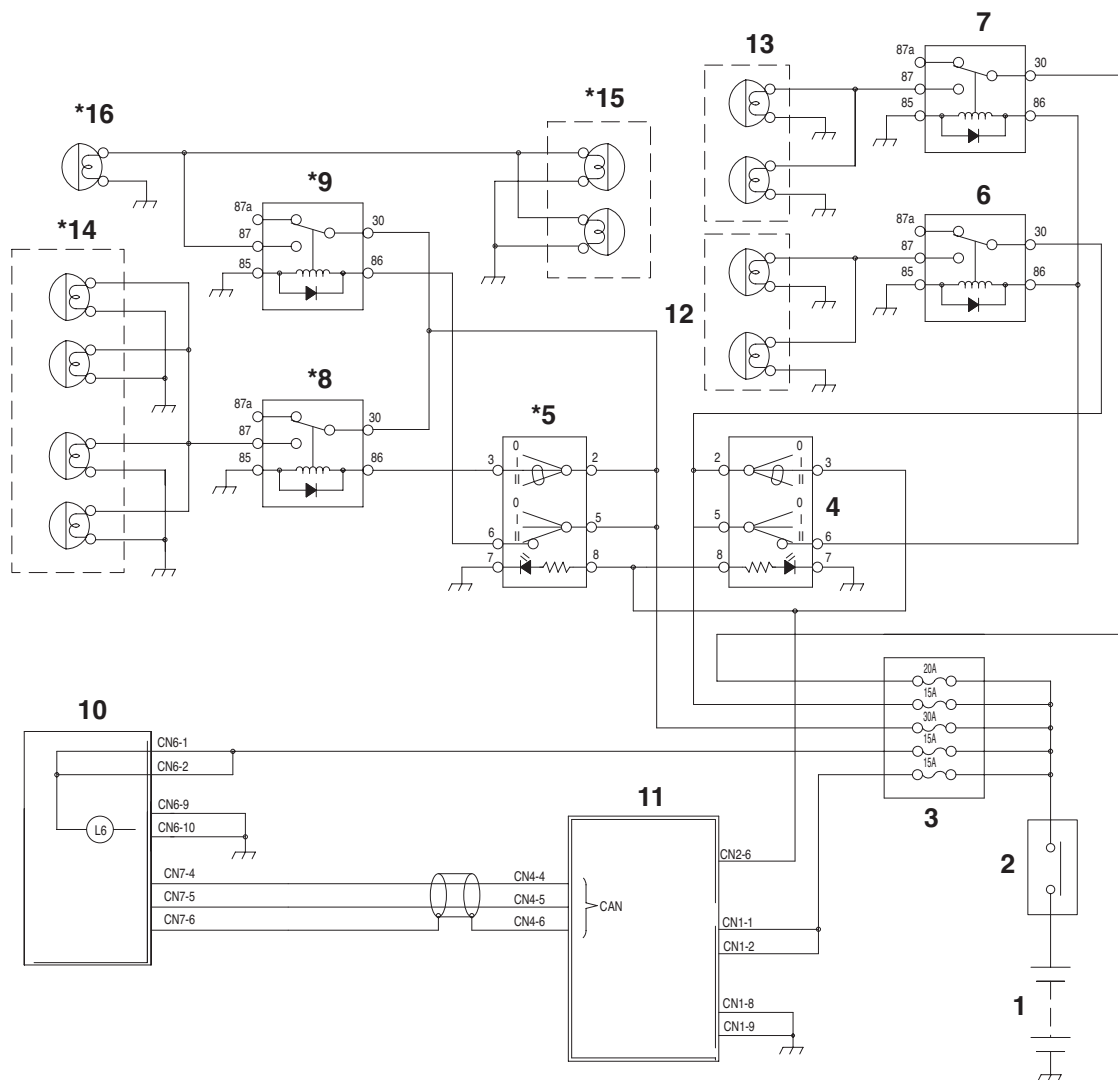

FG000590

Figure 96

Reference Number	Description
1	Battery
2	Battery Relay
3	Fuse Box
4	Light Switch
5	Cabin Light Switch
6	Headlight Relay (Work Light Indicate Light)
7	Work Light Relay
8	Front Cabin Light Relay

Reference Number	Description
9	Front Cabin Light / Rear Work Light Relay
10	Instrument Panel
11	e-EPOS Controller
12	Headlight (2 ea.)
13	Work Light (2 ea.)
14	Front Cabin Light (4 ea.)
15	Rear Cabin Light (2 ea.)
16	Rear Work Light (1 ea.)

**NOTE:** The "\*" mark are optional parts.

## Kind of Light

The lighting system is consists of headlights, work lights, cabin lights (optional), relays and switches.

## Operation

Switch	Position	Connected Terminal of switch	Activated Relay	Lit Light
Light Switch	1	"2-3" Terminal	-	Illumination Light of Switch
	2	"2-3" Terminal	-	Illumination Light of Switch
		"5-6" Terminal	Headlight Relay	Headlight (2 Ea.)
			Work Relay	Work Light (2 Ea.) Indicator Light of Work Light (L6)
Cabin Light Switch	1	"2-3" Terminal	Front Cabin Light Relay	Front Cabin Light (2 Ea.) or Front Cabin Light (4 Ea.)
	2	"2-3" Terminal	Front Cabin Light Relay	Front Cabin Light (2 Ea.) or Front Cabin Light (4 Ea.)
		"5-6" Terminal	Rear Cabin Light Relay / Rear Work Light Relay	Rear Cabin Light (2 Ea.) and Rear Work Light (1 Ea.)

# OVERLOAD WARNING DEVICE

## Overload Warning Device Circuit Diagram

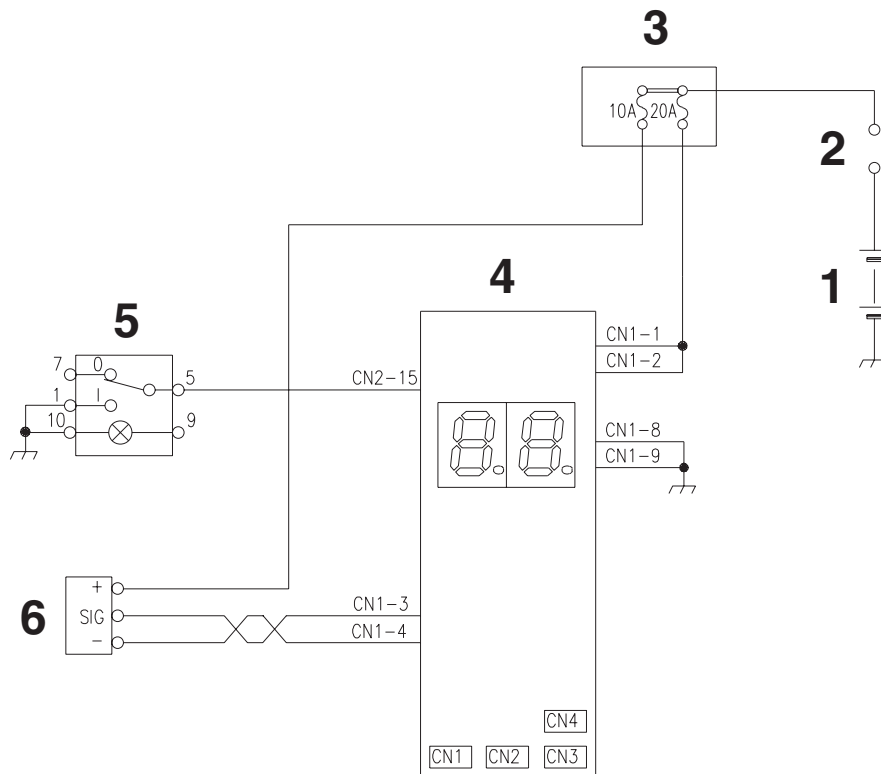

ARS1260L

Figure 97

Reference Number	Description
1	Battery
2	Battery Relay
3	Fuse Box

Reference Number	Description
4	e-EPOS Controller
5	OWD Selector Switch
6	Pressure Sensor

# AUDIO CONTROLLER

## Audio Controller Circuit Diagram

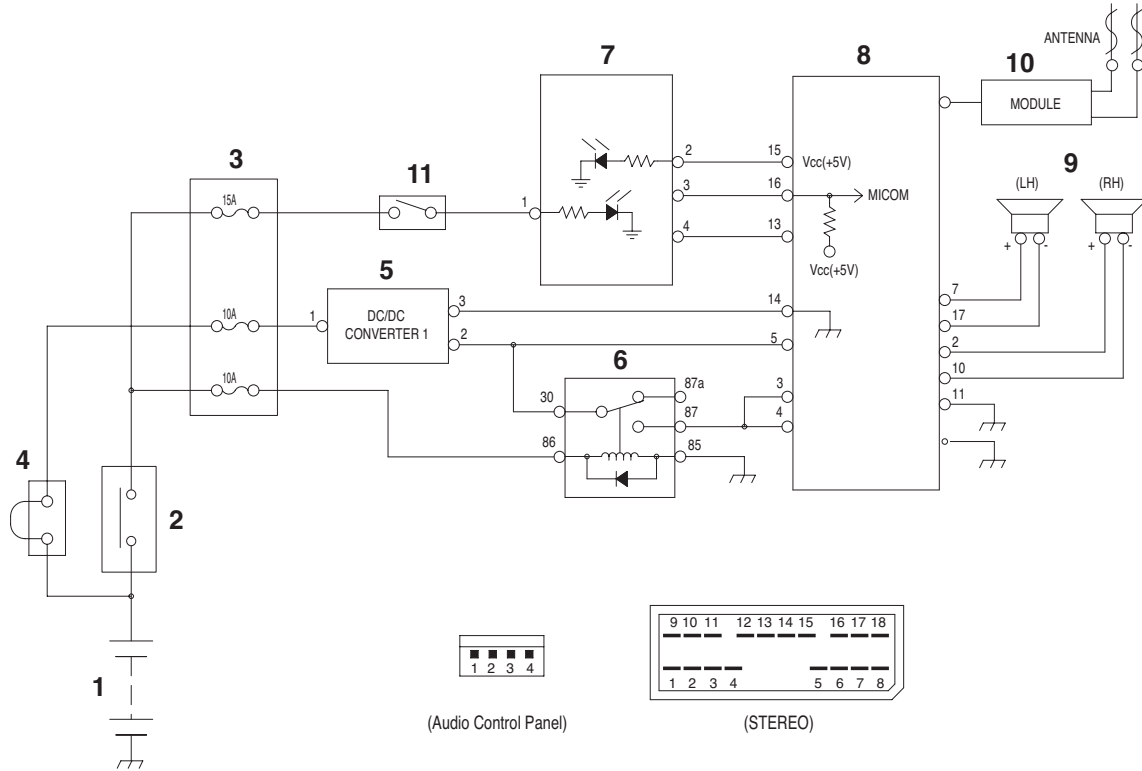

Figure 98

FG000591

Reference Number	Description
1	Battery
2	Battery Relay
3	Fuse Box
4	Fusible Link
5	Converter
6	Stereo Relay

Reference Number	Description
7	Audio Control Panel
8	Stereo
9	Speaker
10	Antenna Module
11	Light Switch

### Operations Via Audio Control Panel

Switch	Connected Terminal of switch	Measured values	Operations
PWR	"3-4"	4.36 ±0.2V	Stereo ON, OFF
▲		1.24 ±0.2V	Volume up
▼		0±0.2V	Volume down
SCAN		2.49 ±0.2V	Frequency selection



# Electrical Schematic (DX225LCA)

Edition 1

---

**MEMO**

---

# Table of Contents

## Electrical Schematic (DX225LCA)

Safety Precautions .....	5
Applicable Models .....	5
DX225LCA.....	7

---

**MEMO**

---

# SAFETY PRECAUTIONS

---



## CAUTION!

---

Follow all safety recommendations and safe shop practices outlined in the front of this manual or those contained within this section.

Always use tools and equipment that are in good working order.

Use lifting and hoisting equipment capable of safely handling load.

Remember, that ultimately safety is your own personal responsibility.

---

## APPLICABLE MODELS

The contents of this section apply to the following models and serial number ranges.

MODEL	SERIAL NUMBER RANGE
DX225LCA	5167 and Up



# DX225LCA

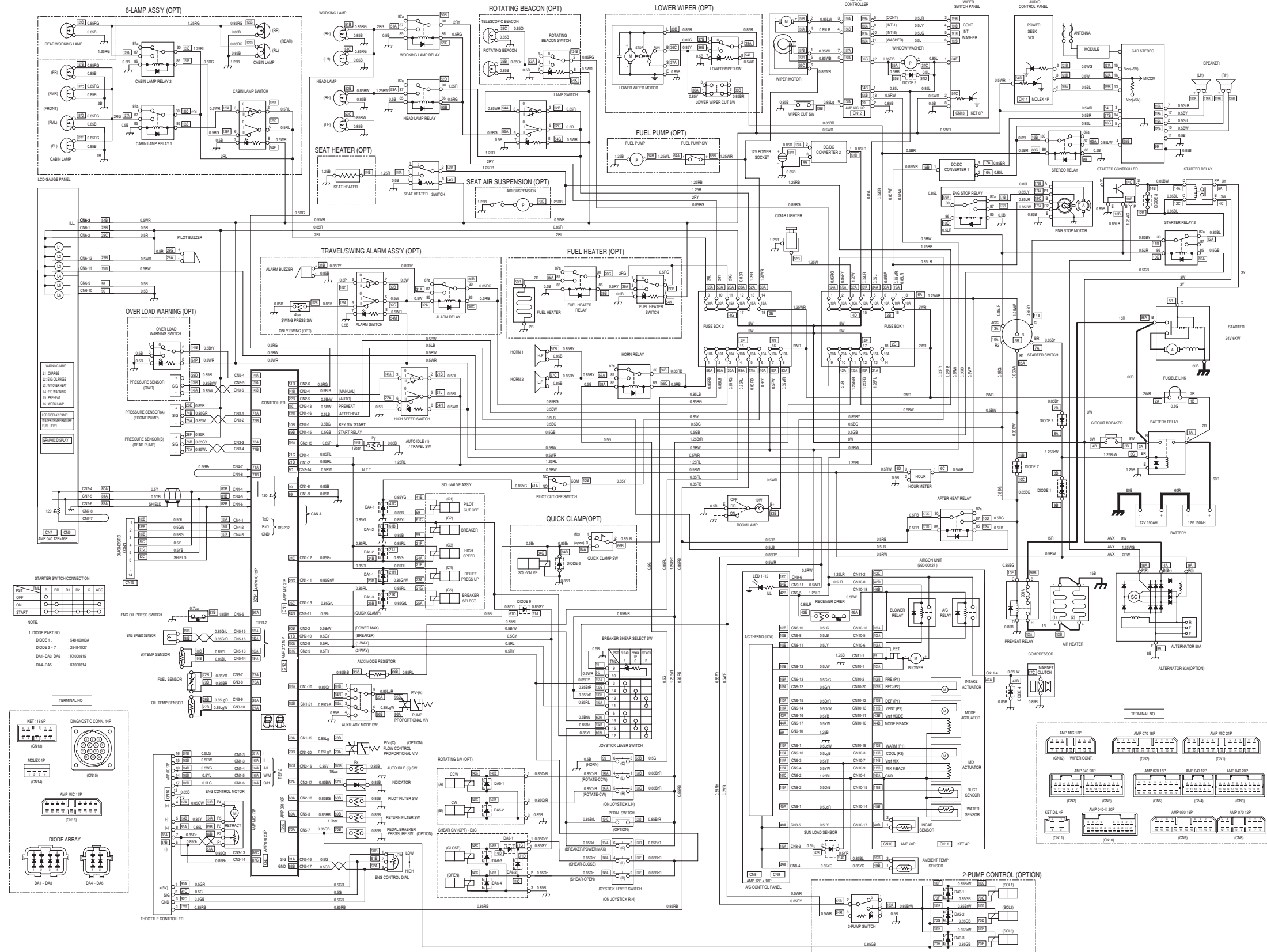

Figure 1

FG014344

# Attachments



# Boom and Arm

Edition 1

---

**MEMO**

---

# Table of Contents

## Boom and Arm

Safety Precautions .....	5
Applicable Models .....	5
Front Attachment Pin Specifications.....	7
Front Attachment - Removal and Installation.....	9
Arm Removal Procedure .....	9
Boom Removal Procedure .....	11
Installation .....	12
Arm Installation Procedure .....	12
Boom Installation Procedure .....	12
Start-up Procedures .....	12

---

**MEMO**

---

# SAFETY PRECAUTIONS

---



## CAUTION!

---

Follow all safety recommendations and safe shop practices outlined in the front of this manual or those contained within this section.

Always use tools and equipment that are in good working order.

Use lifting and hoisting equipment capable of safely handling load.

Remember, that ultimately safety is your own personal responsibility.

---

## APPLICABLE MODELS

The contents of this section apply to the following models and serial number ranges.

MODEL	SERIAL NUMBER RANGE
DX225LC	5001 and Up
DX225NLC	5001 and Up
DX225LCA	5167 and Up



# FRONT ATTACHMENT PIN SPECIFICATIONS

The table below has a complete listing of dimensional specifications for all mounting pins used on the front attachment.

**NOTE:** *Some mounting pins must be drilled and tapped for lubrication fittings and piping, or may have other required specifications. Consult DOOSAN After Sales Service for information on wear tolerances and replacement limits for mounting pins.*

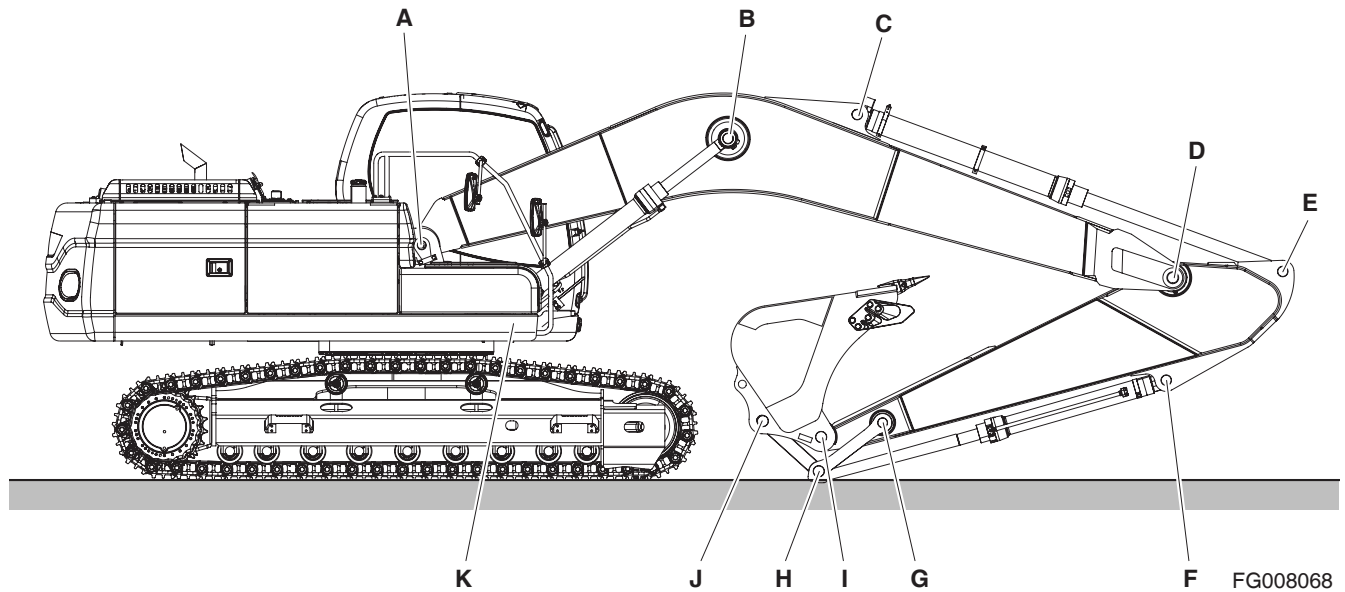

Figure 1

(Unit : mm)

Mark	Measuring Part	Criteria					Remedy
		Standard Size	Tolerance		Standard Clearance	Clearance Limit	
			Pin	Hole			
A	Boom Foot	90 mm (3.543")	-0.10 -0.15	+0.18 +0.03	0.13 to 0.33	1.5	Replace
B	Boom Cylinder Head	80 mm (3.150")	-0.06 -0.11	+0.18 +0.03	0.09 to 0.27	1.5	
C	Boom Center	80 mm (3.150")	-0.06 -0.11	+0.18 +0.03	0.09 to 0.27	1.5	
D	Boom End	90 mm (3.543")	-0.10 -0.15	+0.18 +0.03	0.13 to 0.33	1.5	
E	Arm Cylinder Head	80 mm (3.150")	-0.06 -0.11	+0.18 +0.03	0.09 to 0.27	1.5	
F	Arm Cylinder Rod	80 mm (3.150")	-0.06 -0.11	+0.18 +0.03	0.09 to 0.27	1.5	
G	Bucket Cylinder Head	80 mm (3.150")	-0.06 -0.11	+0.18 +0.03	0.09 to 0.27	1.5	
H	Arm Link	71 mm (2.795")	-0.06 -0.11	+0.18 +0.03	0.09 to 0.27	2.0	
I	Arm End	80 mm (3.150")	-0.06 -0.11	+0.18 +0.03	0.09 to 0.27	2.0	
J	Bucket Cylinder Rod	80 mm (3.150")	-0.06 -0.11	+0.18 +0.03	0.09 to 0.27	2.0	
K	Push Link to Bucket	80 mm (3.150")	-0.06 -0.11	+0.18 +0.03	0.09 to 0.27	2.0	

# FRONT ATTACHMENT - REMOVAL AND INSTALLATION

---

## DANGER!

---

*DOOSAN* warns any user, that the removal of the counterweight from the machine, front attachment or any other part, may affect the stability of the machine. This could cause unexpected movement, resulting in death or serious injuries. *DOOSAN* is not liable for any misuse.

Never remove the counterweight or front attachment unless the upper structure is in-line with the lower structure.

Never rotate the upper structure once the counterweight or front attachment has been removed.

---

## IMPORTANT

---

Always break down the front attachment by removing outermost sections first - the bucket before the arm, the arm before the boom. Reinstallation of the attachment should begin with the boom and end with the bucket.

---

Refer to the appropriate Bucket section for its removal and installation procedure before going onto the initial step of the front attachment removal or installation procedure.

## Arm Removal Procedure

---

## WARNING!

---

This procedure is only intended for routine removal or replacement of the attachment, while working under normal, safe operating conditions. In the event of a major structural collapse of some part of the attachment, an accident or complete loss of attachment hydraulic function, **DO NOT** proceed with attachment disassembly unless you are completely sure of what you are doing. Please call your local *DOOSAN* distributor or *DOOSAN* After Sales Service for assistance. **DO NOT** allow personnel to stand underneath a weakened or only partially supported attachment section. Keep clear of hydraulic lines that may have fluid escaping at high-pressure - it can cause severe or even fatal injuries.

---

Complete the bucket end removal procedure by pulling out the two bucket linkage pins and the bucket cylinder mounting pin, on the arm. Use an assist crane or hoist to lift the cylinder and relieve weight on mounting pins.

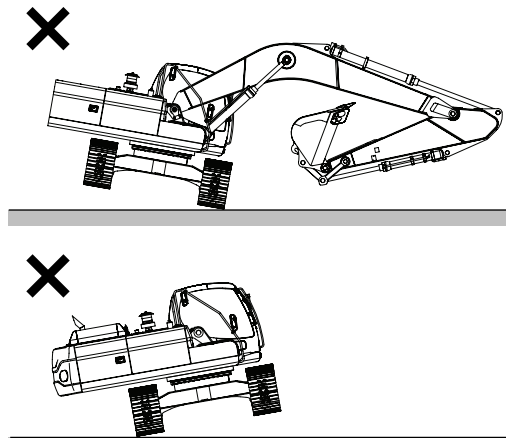

Figure 2

FG000371

Park the excavator away from obstructions and all traffic on clear, flat, level ground. Extend the arm cylinder and crowd the arm into the boom. Partially retract the boom cylinder so that the boom is stretched out in front of the excavator, as low to the ground as possible, with the arm crowded under the boom.

The tip of the arm point should be lowered to secure blocking that will safely support the weight of the arm. Place the blocking directly in front of the excavator and make sure that it will not be unbalanced with an initial weight load that is all to one end, under the arm point.

Shut off the engine and release hydraulic system pressure - move any of the control levers with the engine off to release pressure built up in the accumulator. Manually vent residual hydraulic pressure in the tank by moving the lever near the cap, on top of the reservoir.

---

 **WARNING!**

---

**Secure the swing lock and tag and lock out controls in the operator's cabin to keep anyone from moving or inadvertently starting the engine. Restrict access to the work site while sections of the attachment are in the air, or while they are being supported by the assist crane. The safe lifting capacity of the assist crane or hoist that is used must exceed the weight of the heaviest section of the attachment, the boom (approximately 1,500 kg [3,307 lb], not including the weight of accessories or fixtures).**

---

Before beginning the disassembly of attachment mounting pins, disconnect the arm cylinder hydraulic hose couplings and put a clean plug in the end of each one. Use any and all reasonable precautions necessary to avoid introducing dirt or other contaminants into the hydraulic system. Wipe down coupling points before disconnecting hydraulic lines and use evaporative type solvent spray cleaner. Tag and mark hoses for reassembly, if necessary.

Place a sling under the arm cylinder (the cylinder used to extend and retract the attachment arm, pinned to the top of the boom). Lift the sling so that the weight load on the rod end of the arm cylinder (pinned to the ears on the inner end of the arm) is released. Prepare blocking under the arm that will securely support the weight of the arm and arm cylinder.

---

 **CAUTION!**

---

To make sure that the polished surfaces of cylinder rod ends will not suffer accidental damage during disassembly or removal procedures, wrap exposed rod surfaces (especially those of boom cylinders) with a protective covering material. Immediately following disassembly and removal, cylinder rods should always be fully retracted. This eases handling problems and also avoids possible damage.

---

Remove retainers on the end of the mounting pin for the arm cylinder rod end. Use the assist crane to relieve the weight load and withdraw the pin. Lower the arm down to the blocking support for any continued disassembly procedures.

## Boom Removal Procedure

**NOTE:** *Boom removal may be simplified if the shell of the operator's cabin is taken off the turntable deck first. Refer to the Operator's Cabin Removal procedure before continuing, if both components are to be removed from the excavator.*

After the bucket, arm and arm cylinder have been removed, lower the end of the boom to a stable, secure blocking support.

Attach the assist crane sling to the body of either boom cylinder, break the mounting pin connection to the boom by tapping through the pin from the same side of the boom and repeat for the opposite cylinder.

Release hydraulic pressure and disconnect line couplings as previously outlined in the Arm Removal Procedure, observing the same precautions.

Disconnect wiring for work light assemblies and any other accessory lines or connections. Locate the sling of the assist crane near the center of gravity, optimum lift point for the boom, and use the crane to take pressure off the boom foot pin. Drive out the pin after disassembling retainers and carefully lift away the boom.

---

 **WARNING!**

---

Traveling the excavator, swinging the turntable or movement over bumps or sloping, uneven surfaces could all produce loss of control and possible accidents or injuries, if the turntable deck has been unbalanced by removal of weight from one end only.

---

To maintain stability, the counterweight should be removed whenever the front attachment is taken off the machine.

# INSTALLATION

## Arm Installation Procedure

Reattach the base of the arm cylinder to the mounting point on top of the boom.



---

**Before assembling the front attachment, make sure that the individual boom, arm and bucket sections are all compatible and can be used safely for work intended. Refer to the General Safety Pages, Lift Ratings, Working Range Diagrams and Weights of Materials sections in the Operation and Maintenance Manual. Consult your dealer or DOOSAN After Sales Service for more information if you have any questions or require more information.**

---

Begin with the arm securely supported on blocking in front of the excavator. Grease the mounting pin for the rod end of the arm cylinder and push it through the ears on the end of the arm. Attach a sling around that mounting pin and lift the arm with an assist crane until it is in position for the boom-arm pin connection to be made.

Relieve hydraulic pressure from all points of the system before any hydraulic lines are opened, then carefully assemble hydraulic connections to the arm cylinder.

Remove the sling from around the rod end arm cylinder pin, withdraw the pin and lift the body of the arm cylinder to re-pin the mounting connection.

## Boom Installation Procedure

Before reassembling the attachment, make sure to inspect all bushings and pivot points of each section. To avoid damaging the seats, bushings should never be hammered or chiseled out of their seats.

Installation is otherwise a reversal of the removal procedures.

## START-UP PROCEDURES

Once the boom has been serviced, it should be lubricated as outlined in the initial start-up procedures of the operation manual. Refer to the appropriate operation and maintenance manual for unit.

# Bucket

Edition 1

---

**MEMO**

---

# Table of Contents

## Bucket

Safety Precautions .....	5
Applicable Models .....	5
Bucket Tooth Inspection and Replacement.....	7
Bucket O-ring Replacement .....	8
Bucket Attachment, Removal and Reversal .....	10
Detaching the Bucket .....	10
Attaching the Bucket .....	10
Reversing the Bucket .....	11

---

**MEMO**

---

# SAFETY PRECAUTIONS

---



## CAUTION!

---

Follow all safety recommendations and safe shop practices outlined in the front of this manual or those contained within this section.

Always use tools and equipment that are in good working order.

Use lifting and hoisting equipment capable of safely handling load.

Remember, that ultimately safety is your own personal responsibility.

---

## APPLICABLE MODELS

The contents of this section apply to the following models and serial number ranges.

MODEL	SERIAL NUMBER RANGE
DX225LC	5001 and Up
DX225NLC	5001 and Up
DX225LCA	5167 and Up



# BUCKET TOOTH INSPECTION AND REPLACEMENT

There are several different types of attachment methods for replaceable bucket teeth. Some of the most common types are shown in the following drawings.

Bucket teeth are usually replaced in sets but it may sometimes be necessary to replace individual teeth.

Look for the following indications of wear or damage:

- Lock pins protrude unevenly on one side.
- Lock pins have been worn down so far that they no longer make full contact through the length of the pin hole.
- Lock washers or pins show obvious damage or weakness.
- Wear points on the working surfaces of tooth points - pits, cracks, chips or craters - are larger than 8 mm to 10 mm (1/3" to 1/2") across.

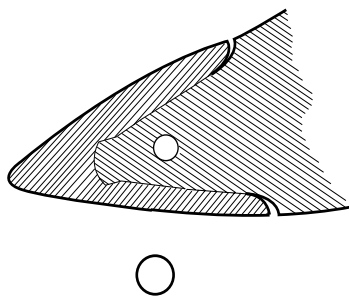
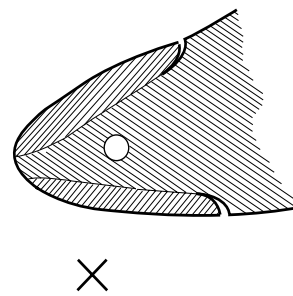

Figure 1



HAOC680L

1. On a routine basis, inspect the bucket teeth to make sure that tooth wear or breakage has not developed. Do not allow the replaceable bucket teeth to wear down to the point that the bucket adapter is exposed. See Figure 1.
2. To replace a tooth (1, Figure 2), use a hammer and punch to drive the locking pin (2) and lock washer (3) out of the tooth adapter (4).
3. Once the worn tooth has been removed, use a putty knife to scrape the adapter as clean as possible.
4. Slide the new tooth into position and insert the lock washer.
5. Insert the locking pin into the tooth and with a hammer, drive the pin in until the lock washer seats in the locking groove.

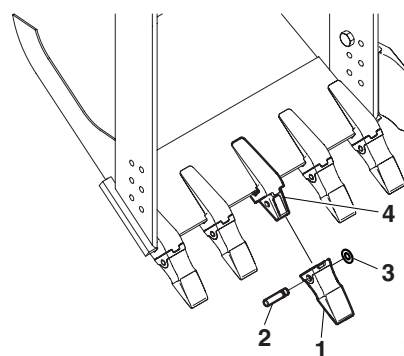

Figure 2

FG000346

# BUCKET O-RING REPLACEMENT

## WARNING!

Due to possibility of flying metal objects, always wear safety helmet, protective gloves and eye protection when changing pins.

1. Inspect the bucket O-rings on a routine basis. If worn or damaged, replacement is necessary.

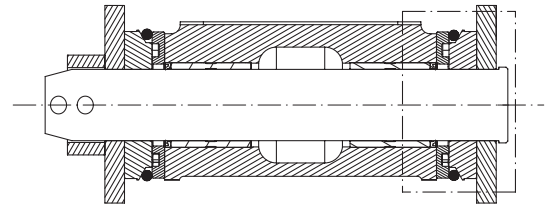

FG007780

Figure 3

2. Roll the old O-ring (1, Figure 4) onto the boss (2) around the bucket pin (3). Remove the bucket pin and move the arm or bucket link (4) out of the way.

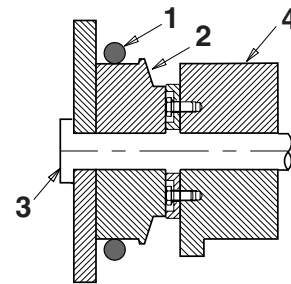

ARO1390L

Figure 4

3. Remove the old O-ring and temporarily install the new O-ring (1, Figure 5) onto the bucket boss (2). Make sure that the O-ring groove on both the bucket link (4) and boss have been cleaned.
4. Realign the arm or link with the bucket pin hole and insert the bucket pin (3, Figure 4).

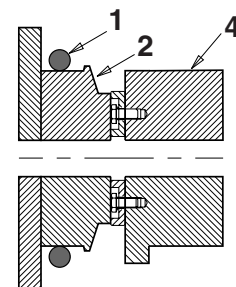

ARO1391L

Figure 5

5. Roll the new O-ring (1, Figure 6) into the O-ring groove.

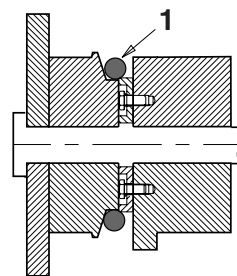

**Figure 6**

ARO1392L

# BUCKET ATTACHMENT, REMOVAL AND REVERSAL

## Detaching the Bucket

Park the excavator away from obstructions on clear, flat, level ground. Lower the bucket carefully to preassembled blocking on the ground. Brace the bucket so that there is no load weight on the pin connecting the bucket and arm. Disassemble the fasteners on the end of the bucket pin and pull out the pin.

If the pin sticks and resists normal withdrawal, there may be a load on it. Raise and lower the arm slightly until an unstressed pin position is located.



---

**Use care pulling out the pin to avoid damaging the dust seals on either end of the arm.**

---

When the pin has been withdrawn, move the operating joystick slightly to take weight off the remaining link pin. Disassemble the link pin end retainers and pull out the pin.

Lift the arm away from the bucket so that the bucket can be carried away or another end attachment can be put on the excavator.

## Attaching the Bucket

Carefully inspect all parts before reassembling the bucket linkage. Look for cracks or any other evidence of physical damage and replace any seal or O-ring that is not in like-new condition. Prelube linkage pins before reassembly.

Use an old cylinder rod, a long breaker bar or a similar, relatively thin diameter support bar for making the first (temporary) pin connection, between the bucket and arm. If the support bar is straight, the arm can be raised and the bucket will hang level, allowing direct insertion of the bucket ear-attachment linkage pin.

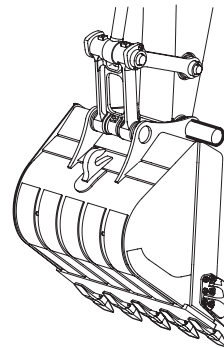

**Figure 7**

FG000606

When the link pin has been installed, withdraw the temporary support rod from the bucket pin holes, lower and raise the arm and boom and install the bucket pin.

---

**! WARNING!**

---

When making linkage alignments, never insert fingers into pin holes. The attachment or bucket could shift position and cause a severe injury. Match holes by visually lining them up. Use the sharp-tipped, soft point of a pencil or a similar tool to check for high spots or irregularities.

---

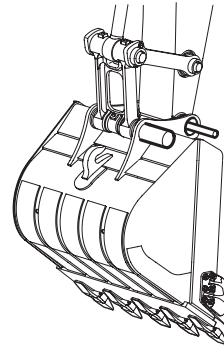

Figure 8

FG000607

## Reversing the Bucket

Follow instructions for "Detaching the Bucket" and remove both the bucket and link pins. Rotate the bucket 180° to change bucket configuration. This procedure is greatly simplified if some type of rotating or swiveling support can be used, on the ground underneath the bucket. Follow instructions for "Bucket Attachment" to replace pins.

---

**! WARNING!**

---

Bucket curl and dump levers must be used in opposite directions, after the bucket has been reversed.

---

