

FPA - 318

Feeder Precision Auto

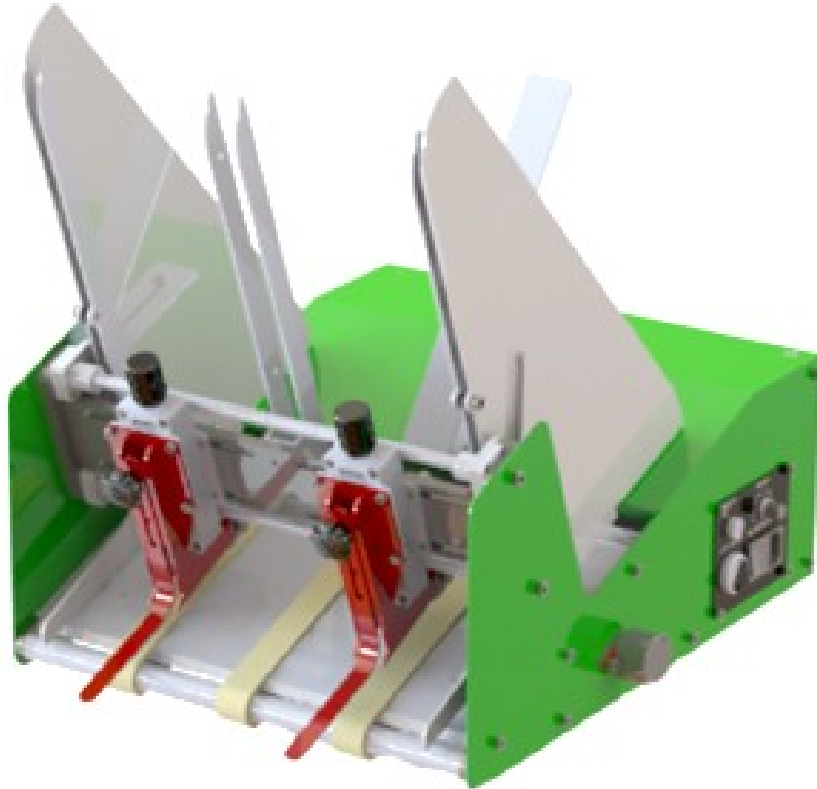

Overview

The most reliable and safest continuous IJ feeder in the market today!

With CE approval, you can be assured that you have the safest machine both mechanically and electrically and we back it with a two-year limited warranty. The V-1000 is capable of feeding flat and multi-thickness products into mail production streams consistently at high speeds with exceptional alignment qualities. The importance of straight feeding and minimizing skewing can help improve USPS® MERLIN™ verification results, leading to significant savings for a mailing service company.

Feed a wide variety of flat and multi-thickness products into production mail streams including inkjet addressing systems, tabbers, labelers, and more.

Standard Features

Repositionable feed belts , Independent side guide positioning ,Extended guide rails all the way through the feeder , Two independent adjustable product separators , Long lasting natural gum rubber feed belts , Variable speed control , Universal external run interface kit



Technical Data

FPA - 318

Specification

Maximum Product Size : 318W x 450L mm.

Minimum Product Size : 28W x 50L mm.

Product thickness : 0.055-12.000 mm.

Belt Speed : 60 m/min

Utilities : 220 Volt, 50/60 Hz. 3A

Weight 30.3 kg.

Warranty 1 Year

Applications *(ask us about your application)*

Addressing

Scanning

Coding

Labeling

Tabbing

Printing

Products *(ask us about your product)*

Sheet Paper

Backer Board

Folders

Manuals

Cardstock

Envelopes

Collapsed Cartons

Post Cards

Bookbank

Brochures

and more.....

Dimension

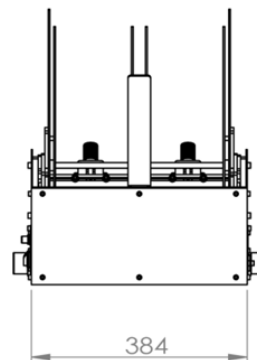
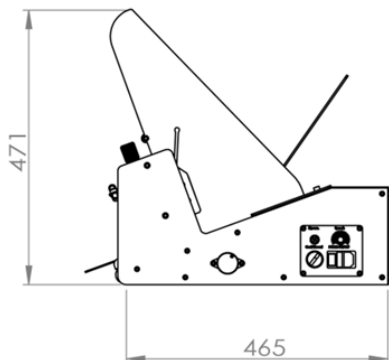
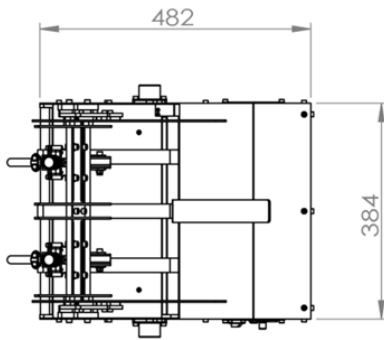

PRO PAK PRECISION
We will walk together with success

Pro Pak Precision Ltd.

555/112 Sai-Mai, Sai-Mai 10220

Thailand

Phon : +66(0)2-990-5986

E-Mail : salepropak@gmail.com