

Specifications

Model name	Handy Hardness Tester SONOHARD® SH-21(E) (Motorized/manual switchover type probe)	Display make-up	a. Measured value: 3 digits b. TIMES: 2 digits (measuring frequency) c. MAX value: 3 digits d. MIN value: 3 digits e. σ : 4 digits (standard deviation) f. \bar{x} : 4 digits (average value)
Measuring indenter	Diamond indenter for Micro-Vickers (facing to surface angle of 136°)	Set-up	a. UPPER (upper limit) b. LOWER (lower limit) c. TIMES (measuring frequency) d. CANCEL
Test load and control no. CE making complied models are required to add (CE) with control no.	1. Approx 2kgf (roughly 20N) SH-21-E2 2. Approx 1kgf (roughly 10N) SH-21-E1 3. Approx 4kgf (roughly 40N) SH-21-E4 (special type manual probe only)		
Measuring range	1. Rockwell hardness HRC 10.0~70.0 2. Vickers hardness HV 100~999 3. Shore hardness HS 20.0~99.9 4. Brinell hardness HB 85~550		
Reproducibility	HRC : ± 1.0 HRC, HV : $\pm (3\%rdg)$ HV, HS : ± 1.0 HS, HB : $\pm (3\%rdg)$ HB	Alarm	a. Alarm (buzzer sound)
Applicable test materials	With steel as the principle material, other metallic materials may also be measured by calibrating against a standard hardness test block.	Output	a. RS-232C output used for data transmission or printing
Display of measured values	Digital display (LCD, 4 digits) with EL backlight	Frequency	1. Motorized / manual switchover type approx 69~71kHz 2. Manual type (special type) approx 38~40kHz
Data memory	2,000 pieces		
Digital display units	1HV, 0.1HRC, 0.1HS, 1HB, 1N/mm ² (tensile strength)	Conversion	HV, HRC, HS, HB, N/mm ² according to JIS B 7731, ASTM E 140, DIN 50150
Allowable operating temperature	0~50°C		
Power source	AC adapter(100~240V) or lithium ion rechargeable battery	Options	Standard hardness test blocks HV600, HS50, HB300 used for scale calibration, Measuring stand for small objects (SH-S02), Probe attachment for pipes materials (UA4-4005), Probe attachment for inner races (UA4-4006), Printer model DPUH245AS with cable, Printer paper (TP-H241L), Stand for the main unit (SH-P03)
Continuous operating hours	5 hours when featuring a rechargeable BL; 8 hours without BL *BL= backlight		
Dimensions	Display unit: 97(W) x 50(D) x 170(H) mm, Probe diameter: 40mm, length: 164mm		
Weight	Display unit: approx. 400g (including battery), Probe and cable: approx. 400g		
Carrying case dimensions	400(W) x 220(D) x 140(H) mm		
Standard components	1 display unit, 1 probe (including standard attachment/UA5410), 1 hardness standard test block (around HRC55), 1 probe cable 1.5m, 1 AC adapter 100~240V (A05C1-09MI), 1 recharger (MK-8220), 1 lithium ion battery (MK-8401), 1 carrying case (MK-9701)		

- When using the tester installed in automated machinery, please contact our hardness tester sales department for specifications concerning the testers used for automatic machines.
- In order to make it possible to propose ideas regarding the unique loads, jigs and measuring methods to our customers, we humbly request that you fill out a specification confirmation form when making inquiries concerning usage.
- The SONOHARD SH-21(E) is calibrated using the standard hardness test block produced in compliance with JIS B7730/ ISO 6508-3 and JIS B7735/ ISO 6507-3 by Yamamoto Scientific Tool Laboratory Co., Ltd., Japan, who has the quality management system approved under ISO 9001. The values measured by SH-21(E) are therefore guaranteed by us.
(Measured values under the calibration using other makers' test blocks are out of our guarantee.)
- The model name on the catalog is SH-21(E), while it is referred to as SH-21 only in the relevant operation manual, test certificate and ISO certificate, etc.
- A standard export model of SH-21(E) is not CE-Marking complied, but a CE-Marking complied model is also available by factory modification on request and order beforehand.

* Please read the user's manual before undertaking operations.
* Specifications may be changed without prior notice due to product revisions.

JFE Advantech Co., Ltd.
formerly Kawatetsu Advantech Co., Ltd.
URL : <http://www.jfe-advantech.co.jp/>

Tokyo Head Office (Overseas Sales)
JFE Kuramae Bldg., 2-17-4 Kuramae, Taito-ku, Tokyo
111-0051, Japan
e-mail: tokyo@jfe-advantech.co.jp Tel. +81-3-5825-5577 Fax. +81-3-5825-5591

Head Office and Main Plant
3-48, Takahata-cho, Nishinomiya-shi, Hyogo Pref.
663-8202, Japan
e-mail: honsha@jfe-advantech.co.jp Tel. +81-798-66-1508 Fax. +81-798-65-7025

Handy Hardness Tester

SONOHARD® SH-21(E)



Perfect for use in making on-site measurements **CE**

Maintenance for large-scale structures, vehicles, ships, steel towers, bridges, aviation aircraft and so on carried out by making hardness measurements

Used for measuring the hardness difficult to get at areas, grooved areas and internal R-sections of compact parts, metal casts, gears, crank shafts and component parts

Special characteristics Strong points

- Measurement possible in just a few seconds.**
Makes it possible to reduce measurement time.
- Extremely minute indentations (approximately 0.1mm²).**
Can be used for product inspections, as indentations are virtually unnoticeable.
- Direct reading of hardness values (HV, HRC, HS, and HB).**
The hardness value can be obtained with one measurement without using calculation formulas.
- Conversion to tensile strength (N/mm²).**
The level of the strength of materials can be converted according to tensile strength values.
- Measuring tables (wooden, iron, resin, etc) do not affect measurement.**
Can be used without worrying about the location of measurement.
- The backsides of test samples do not affect measurement.**
Measurements can be made without being influenced by the backside of work pieces.
- Data can be stored in memory up to 2,000 pieces.**
Data can be managed easily using customer's own developed software of data transfer to PC.
- 10 pieces of calibration memory.**
It is not necessary to re-calibrate every time the nature of the work changes.
- The handy recharge pack makes it easy to carry out on-site measurements.**
This makes it possible to measure steel towers, ships, large-scale parts, complexly arranged parts and other items both indoors and outdoors in their natural state.
- Free measuring ability in all directions.**
Not only vertically and horizontally but all directional measurements can be made without any compensation.
- Beneficial to reducing costs by making periodic part replacement unnecessary.**
Static pressure types of loads eliminate the need for temporary parts and annual replacement.
- Hardening and annealing can be controlled according to hardness levels.**
It is possible to check the state of hardening and annealing of repaired metal casts according to their hardness levels.
- Possible to make output to an external printer (optional).**
This makes it possible to quickly record measurement data using a printer on site.
- Upper and lower limit alarms can be established.**
It is possible to set up alarms to notify if the allowable limits of a work piece have been surpassed.



Made in Japan by
JFE Advantech Co., Ltd.

The Handy Hardness Tester (SONOHARD®) model SH-21(E) differs completely from traditional hardness testers from a viewpoint that instead of measuring the size of the indentation of the test sample using a microscope, it employs a diamond indenter equipped with a vibrating rod that presses on the test surface at a fixed force and then measures its hardness by applying ultrasonic vibrations.

When the vibrating rod is applied to a soft-surfaced test sample with identical qualities and at a fixed force, it makes a deep indentation and gets locked into the groove. Due to this, the resonance frequency increases. Conversely, it does not get locked in when used on hard test samples and the resonance frequency drops. The test sample's hardness can be calculated using the correlation between this deviation and the tested hardness.

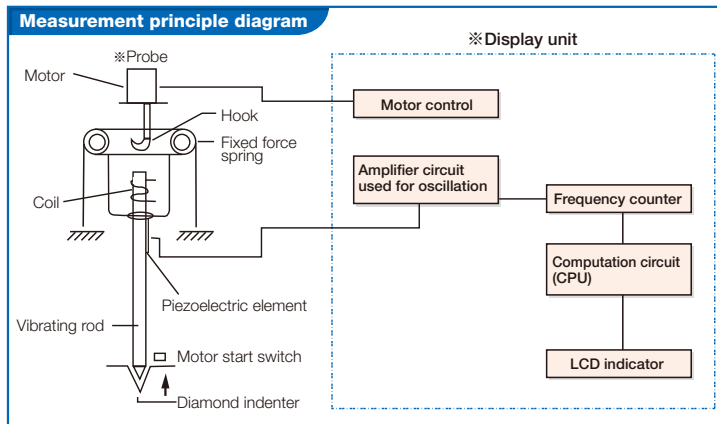
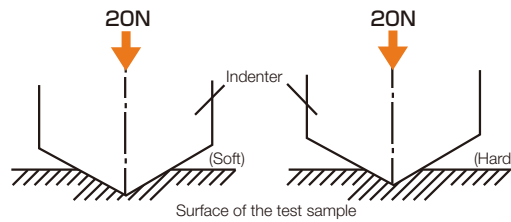

Calculation values of SH indentation

Load P= approx. 2kgf (approx. 20N)

Hardness HV	Calculation value, Size of indentation (mm)	Calculation value, Depth of indentation (mm)	Conversion value, HRC
100	0.193	0.028	—
200	0.136	0.019	15
300	0.111	0.016	31
400	0.096	0.014	41
500	0.086	0.012	49
600	0.079	0.011	55.5
700	0.073	0.010	60.5
800	0.068	0.010	64.5
900	0.064	0.009	67.5

Load P= approx. 1kgf (approx. 10N)

Hardness HV	Calculation value, Size of indentation (mm)	Calculation value, Depth of indentation (mm)	Conversion value, HRC
100	0.136	0.019	—
200	0.096	0.014	15
300	0.079	0.011	31
400	0.068	0.010	41
500	0.061	0.009	49
600	0.056	0.008	55.5
700	0.051	0.007	60.5
800	0.048	0.007	64.5
900	0.045	0.006	67.5

Probe dimensions

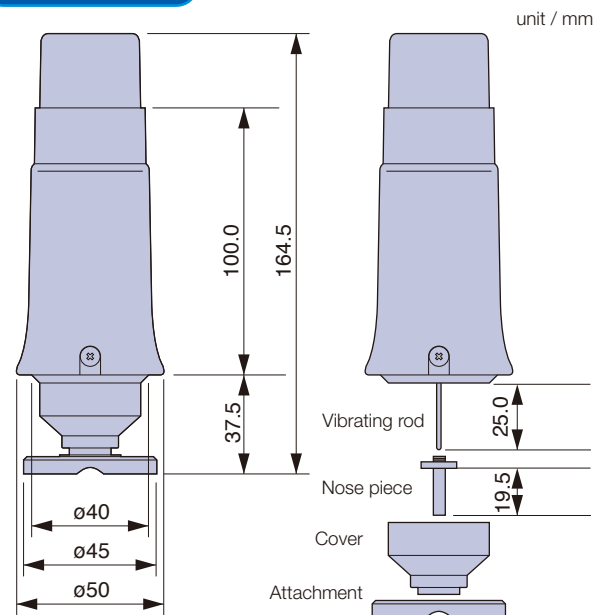

Precautions on measurements

1. The affect of surface roughness

Hardness	Surface roughness	Average value \bar{x} Standard deviation σ Measurement frequency per 100		
		0.8a	1.6a	3.2a
HRC31.5	\bar{x}	31.5	31.7	30.9
	σ	0.4	0.5	0.8
HRC50.8	\bar{x}	50.5	50.5	50.3
	σ	0.3	0.3	0.6
HRC65.5	\bar{x}	65.4	65.3	65.1
	σ	0.2	0.2	0.4

● For items with a roughness of 3.2a or greater, you will need to polish the surface before making measurements. If decarbonization occurs, make measurements after having removed it.

2. Measurable dimensions (For loading of 2kgf/approx. 20N)

- ① Size : 15mm wide x 15mm long or greater ② Thickness t= 7mm or greater
- For items smaller in dimension than those listed above, you will need to use a stand with dimensions of $\phi 50 \times 15$ mm or greater, and make measurements after securing the item to the stand by applying oil and after increasing the virtual mass.
- For loading of 1kgf/approx.10N, it is possible to make measurements even at t=7mm or less.

3. Angles and deviations

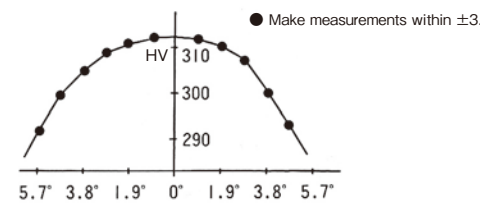

4. Reproducibility

When making measurements on a standard test block using a measuring stand

HV hardness	Average value	Standard block	Stand measurement	Hand-held measurement
		HV200	199	201
500	508	500	504	508
		800	806	790

※ 30 measurements

Utilization of the Handy Hardness tester SH-21

Examples of quality control and maintenance usage by measuring hardness



● Processed goods, Press parts, Metal mold



● Tapered parts



● Car wheels



● Diagnosing wear and tear using hardness measurements



● Drill blade



● Measuring the strength of welding sections (Checking tension strength)

Measuring metal fatigue in steel towers, bridges and reinforcing bars



Measurements with Measuring stand for small objects

