

FEATURES

คุณสมบัติพิเศษ

Twin impeller centrifugal pumps with hydraulic manufactured from cast iron, suitable irrigation and non-aggressive liquids for civil and industrial uses.

ปั๊มคอปเปลิ่งใบพัดคู่ โดยมีชิ้นส่วนการผลิตด้วยเหล็กหล่อ เหมาะสำหรับงานสวน ไร่เกษตร และของเหลวที่ไม่กัดกร่อนในงานอุตสาหกรรมทั่วไป

SPECIFICATIONS รายละเอียดเฉพาะ

- * Maximum working pressure : แรงดันในมตรทำงานสูงสุด
6 bar for CB 80-100
10 bar for other models
- * Maximum liquid temperature : อุณหภูมิของเหลวสูงสุด
45 °C for CB 150A - 200A - 300A
80 °C for CB 80-100-150-200-300-400-550-750, CB 750B -1000B - 1250B - 1500B



MATERIALS วัสดุ

- * pump body in cast iron
เสื้อปั๊มทำด้วยเหล็กหล่อ
- * Mechanical seal in carbon/ceramic/NBR
พนักเชิงกรทำด้วยคาร์บอน/เซรามิก/ยางNBR
- * Impeller :
in bronze for CB
in noryl for CB-A
in cast iron for CB-B
- * Shaft :
in AISI 304
เพลาทำด้วยสแตนเลส AISI 304
- * Bracket :
in cast iron
หมั้แปลนมอเตอร์ทำด้วยเหล็กหล่อ
- * Casing cover :
in cast iron
เสื้อสังปั๊มทำด้วยเหล็กหล่อ

TECHNICAL DATA ข้อมูลเทคนิค

- * T.E.F.C 2 poles motor
- * Insulation class F
- * Protection degree IP44 (IP55 on request)
- * 1~230V ± 10% 50Hz, 3~230/400V ± 10% 50Hz
- * Permanent split capacitor and automatic thermal overload protection for single-phase version
- * Thermal protection to be provided by the user for three-phase version

Note : Specification can be changed without any notice.
หมายเหตุ : สเปคต่างๆ เหล่านี้ อาจจะมีการเปลี่ยนแปลงโดยไม่ต้องแจ้งให้ทราบล่วงหน้า

PERFORMANCE CURVES

CB, CB-A, CB-B (according to ISO 9906 grade 2)

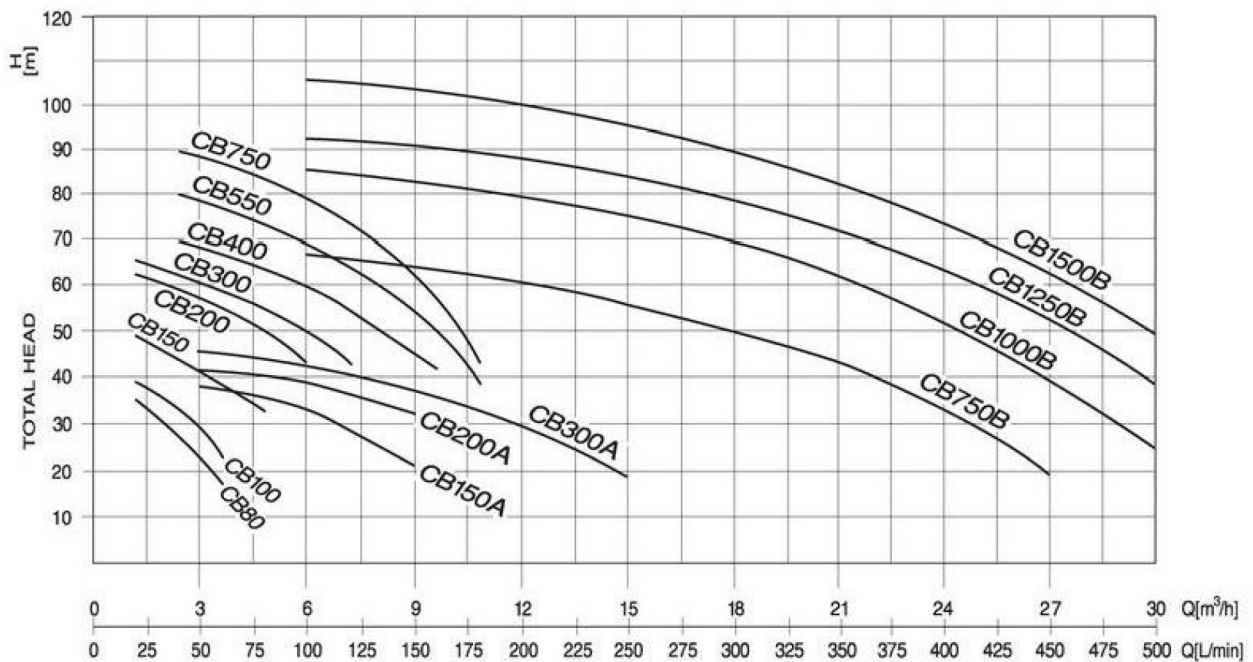

Series CB
Centrifugal Pumps with Two Impellers

เป็นทองเหลืองโดยมีใบพัดคู่เพื่อการส่งสูง

MOD	POWER		CAPACITOR	ABSORBED AMP			Q = DELIVERY												
	HP	KW		MF/450V	230V-M	230V-T	400V-T	M3/H	0.9	1.8	2.4	3.6	4.8	6	7.2	8.4	9.6	10.8	
							LT/MIN	15	30	40	60	80	100	120	140	160	180		
CB/80	0.75	0.55	16	4.5	2.6	1.5	H = MT	36	32	30	20								
CB/100	1	0.75	20	5.2	3.2	1.8		40	36	34	25								
CB/150	1.5	1.1	31.5	8	4.8	3		50	47	45	40	35							
CB/200	2	1.5	40	11.5	6.4	3.8		64	61	60	55	50	47						
CB/300	3	2.2	-	-	9.2	5.2		65	64	63	60	56	51	48					
CB/400	4	3	-	-	14	8			73	71	68	65	67	56	50	43			
CB/550	5.5	4	-	-	17	10			83	82	78	74	70	66	60	52	40		
CB/750	7.5	5.5	-	-	20	11.5			93	91	87	84	80	75	70	59	42		

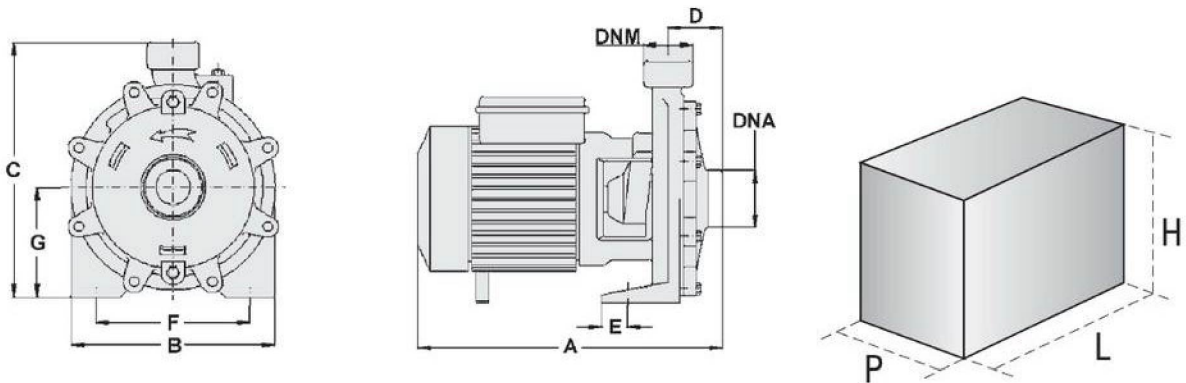
Dimensions
CB

TYPE	A mm	B mm	C mm	D mm	E mm	F mm	G mm	DNA	DNM	L mm	H mm	P mm	KG
CB/80	345	190	235	67	14	156	96.5	1" ¼	1"	365	255	200	15.4
CB/100	345	190	235	67	14	156	96.5	1" ¼	1"	365	255	200	16.4
CB/150	375	225	270	73.5	15	158	114	1" ¼	1"	390	295	235	25
CB/200	375	225	270	73.5	15	158	114	1" ¼	1"	390	295	235	27
CB/300	375	225	270	73.5	15	158	114	1" ¼	1"	390	295	235	28
CB/400	463	266	305	95.5	14	212	135	1" ½	1" ¼	540	360	290	44
CB/550	463	266	305	95.5	14	212	135	1" ½	1" ¼	540	360	290	46
CB/750	463	266	305	95.5	14	212	135	1" ½	1" ¼	540	360	290	46

Series CB-A
Centrifugal Pumps with Two Impellers

เป็นเครื่องกลที่นำพลังงานไฟฟ้าไปผลิต

MOD	POWER		CAPACITOR MF450V	ABSORBED AMP			Q = DELIVERY																
	HP	KW		230V-M	230V-T	400V-T	M3/H	0.9	1.8	2.4	3.6	4.8	6	7.2	8.4	9.6	10.8	12	13.5	15			
CB150A	1.5	1.1	31.5	9.5	5.5	3	15	30	40	60	80	100	120	140	160	180	200	225	250				
CB200A	2	1.5	35	10.5	6.6	3.8	39	38	37	36	35	32	29	24									
CB300A	3	2.2	40	12.5	8.5	5	43	43	42	41	40	38	36	33									
							45	45	44	44	43	42	40	38	36	33	30	25	20				

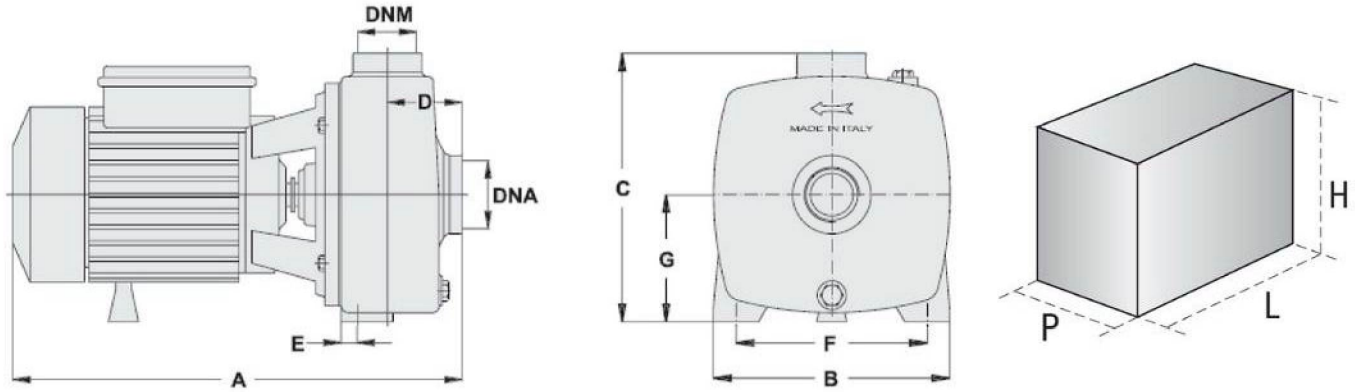

TYPE	A mm	B mm	C mm	D mm	E mm	F mm	G mm	DNA	DNM	L mm	H mm	P mm	KG
CB150A	398	205	225	65	14	166	110.5	1 1/2"	1 1/4"	420	295	235	23
CB200A	398	205	225	65	14	166	110.5	1 1/2"	1 1/4"	420	295	235	24
CB300A	398	205	225	65	14	166	110.5	1 1/2"	1 1/4"	420	295	235	25

Series CB-B
Centrifugal Pumps with Two Impellers

MOD	POWER		CAP MF450V	ABSORBED AMP			Q = DELIVERY																
	HP	KW		230V-M	230V-T	400V-T	M3/H	2.4	4.8	6	7.2	8.4	9.6	10.8	12	13.5	15	18	24	27	30		
CB750B	7.5	5.5	-	-	19	11	40	80	100	120	140	160	180	200	225	250	300	400	450	500			
CB1000B	10	7.5	-	-	28.4	16.4	H = mt			69	69	68	66	64	61	68	65	51	34	20			
CB1250B	12.5	9.2	-	-	32	19.4				87	86	85	84	83	81	79	75	70	52	40	25		
CB1500B	15	11	-	-	36.4	23				93	92	91	90	89	88	86	83	79	63	51	39		
										106	105	104	103	102	100	98	95	90	73	61	50		

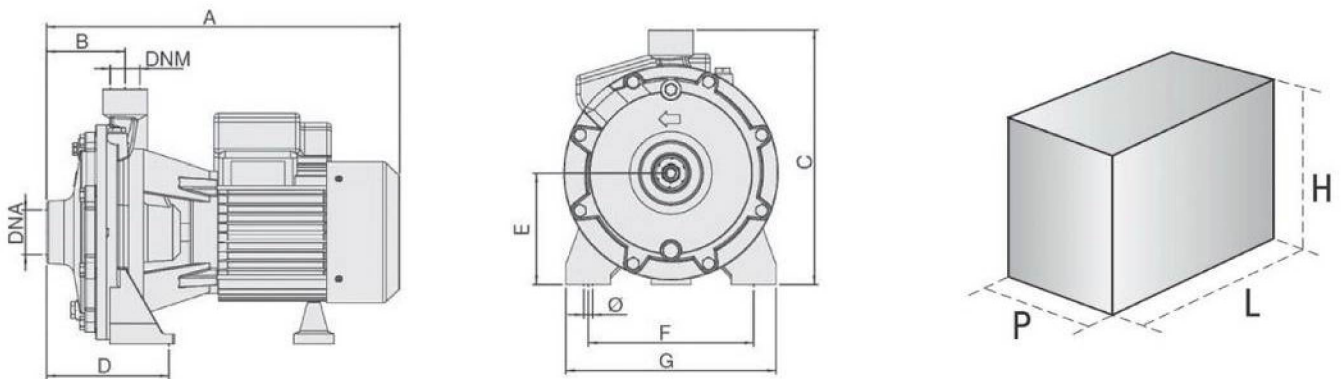

TYPE	A mm	B mm	C mm	D mm	E mm	F mm	G mm	Ø	DNA	DNM	L mm	H mm	P mm	KG
CB750B	540	117.5	345	179.5	160	230	295	13	2"	1 1/2"	650	450	370	65
CB1000B	608	117.5	345	179.5	160	230	295	13	2"	1 1/2"	650	450	370	81
CB1250B	608	117.5	345	179.5	160	230	295	13	2"	1 1/2"	650	450	370	87
CB1500B	646	117.5	345	179.5	160	230	295	13	2"	1 1/2"	720	451	430	95