

DIGITAL LOCK | WS 300

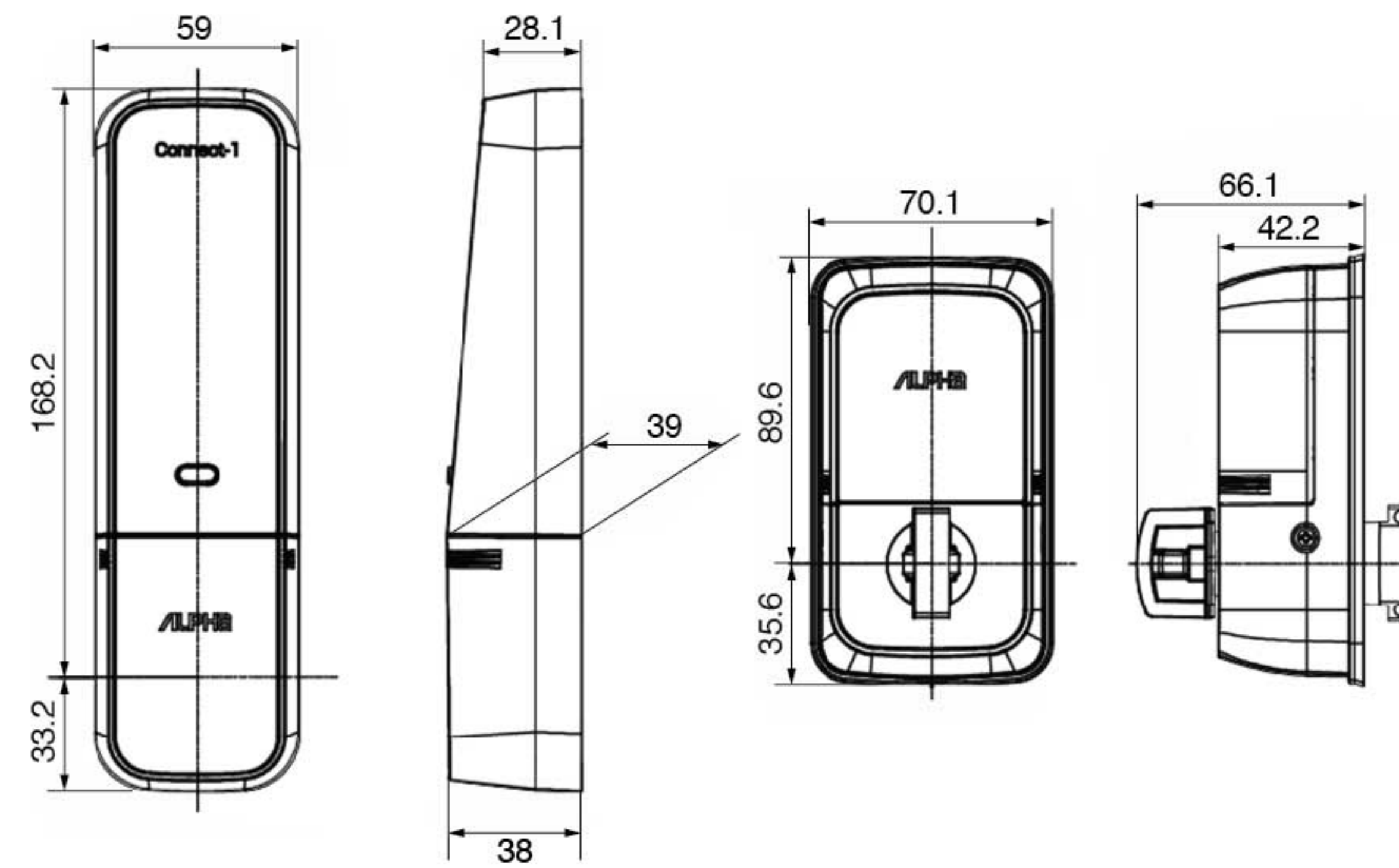

Outer Dimension



Color



SILVER

BLACK

WS300



Password



Card

Card Specification



User Card
(Sell Separately)



Registration card
(2 pcs included)

Feature

- Tamper alarm function**
 Tamper-proof Mode starts when improper operation is repeated 6 times
 When Start Button is pressed at Tamper-proof mode, tamper alarm is triggered and no operation is allowed.
- Auticrime function**
 Set as s factory default for higher security.
 Inputting random numbers can prevent your password form being stolen by fingerprints
- Emergency power supply function:**
 When the battery runs out and can't unlock,
 you can input power by USB-TypeC (Mobile Battery)
- Anti-theft thumbturn function**
 You can't lock or unlock the door if you don't press the thumb turn button.
 This function prevents unauthorized unlocking by turning the thumb turn.
- Timer lock function**
 Timer locking can be set to prevent forgetting to lock the door.
 The door will automatically lock 5 minutes after unlocked
 by password, user card, or manually.

List of Item No.

door thickness	Color	Item No.
32-40	SILVER	9QK18-00100
	BLACK	9QK18-10100

Basic Specification

Variable	:	D/T 32-40mm
Color	:	Silver / Black
password	:	Type Touch Sensor
	:	Digits 4 to 12
	:	ID 2 ID
Battery	:	Power AA alkaline 4 pcs
	:	Life Prox. 2years (5cycles per day)
Size	:	Outside 59mm(W) x 201mm(H) x 39mm(D)
	:	Inside 70mm(W) x 125mm(H) x 66mm(D)
Temperature	:	Unit -30~80°C (Outside)
	:	0~50°C (Inside)
	:	Card -25~50°C
	:	Tag -10~60°C
	:	Battery 5~45°C *The case of Panasonic battery