

Solenoid operated directional control valves DG4V-3

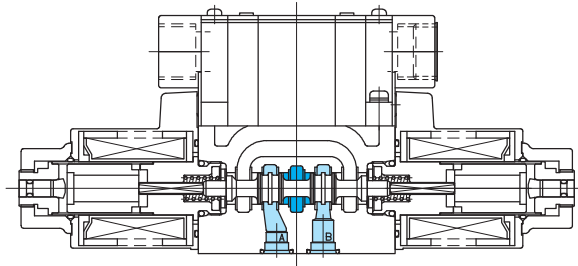
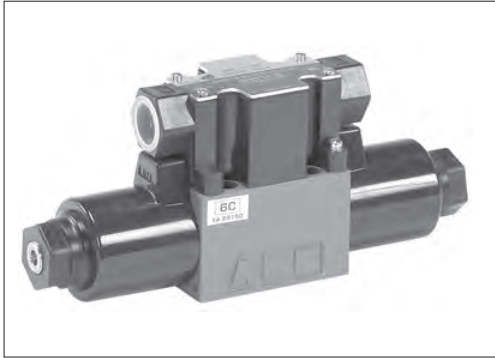

- Wet type solenoid valve boasts superior valve life with low switching noise. No seals on sliding surfaces eliminates leakage worries.
- Many valve options including 3 types of wiring connections, indicator lamp, surge suppressor, and AC/DC rectifier.

E
2-1

Directional Control Valves

Model Code

(F3)-DG4V-3-2A(L)-M-P2-T-7-(P08)-54

1 2 3 4 5 6 7 8 9 10 11 12

- 1 Hydraulic fluid
Omit: mineral oil based fluid, water-glycol based fluid
F3: Phosphate ester
- 2 Solenoid operated directional control valve (gasket mounting)
Wet armature type
- 3 Mounting dimensions
3: ISO 4401-03
- 4 Spool type
See page E2-4 to E2-7
- 5 Spool/spring arrangement
A: Spring offset, A type (2 position, single solenoid)
B: Spring offset, B type (2 position, single solenoid)
C: Spring centered type (3 position, double solenoid)
N: No spring detented type (2 position, double solenoid)
- 6 Solenoid assembly configuration (for spring sets, type A and B)
Omit: standard (energized: P to B, A to T)
L: Left hand build (energized: P to A, B to T)
- 7 Electrical wiring system
P: Plug-in solenoids, conduit box, G 1/2
U: DIN43650 connectors, Pg. 11
KU: Flying leads (standard lead wire length 350 mm, DC 12 V, 24 V only)
- 8 Electrical accessories
Omit: no accessories (electrical wiring P, KU) and for no connectors (electrical wiring U)
1: Connectors without accessories (electrical wiring U)
2: With indicator lamp (AC standard)
4: With surge suppressor (electrical wiring KU, slow solenoid deenergize)
7: With indicator lamp and surge suppressor (DC standard)
9: ADC solenoid rectifier (fast solenoid deenergization), indicator lamp and surge suppressor
12: ADC solenoid rectifier (slow solenoid deenergization), indicator lamp and surge suppressor

Table of electrical accessories which can be selected

Electrical Wiring System	Solenoid Power Supply	Electrical Accessories						
		Omitted	1	2	4	7	9	12
P	AC	○	×	◎	×	○	×	×
	DC	○	×	○	×	◎	×	×
	AC/DC conversion	×	×	×	×	×	○	○
U	AC	○	○	○	×	○	×	×
	DC	○	○	×	×	○	×	×
	AC/DC conversion	×	×	×	×	×	×	○
KU	DC	○	×	×	○	×	×	×

- ◎: Standard
○: Electrical accessory which can be selected
×: Electrical accessory which cannot be selected

- 9 Solenoid voltage
(See page E2-2)
- 10 Allowable T port back pressure
7: 20.6 MPa
- 11 Port orifice (option)
Omit: no port orifices (standard)
Port orifices
<Example 1> P08 (0.8 mm orifice in P port)
┌ Orifice diameter
└ Port (A, B, P and T)
<Example 2> B12 (1.2 mm orifice in B port)
<Example 3> 2 port combinations
Combination sequence, PTAB
P10T12, P08B10, etc.
- 12 Design no.

Specifications

Model Code	Max. Working Pressure MPa	Max. Flow L/min	Allowable Tank Port Back Pressure MPa	Max. Switching Frequency (cycles/min)			Weight kg			
				AC	DC	AC/DC Conversion	Single Solenoids		Double Solenoids	
DG4V-3	35	See "Pressure-Flow Characteristics"	20.6	300	300	120	AC	DC	AC	DC
							1.5	1.6	1.8	2.0

Solenoid Specifications

Power Supply	Voltage Code	Voltage V	Frequency Hz	Initial Current A	Holding Current A	Power Consumption W	Allowable Voltage Fluctuation %	Insulation Class (Allowable Temperature)
AC	T	100	50	2.42	0.52	22	+10, -15	H (180°C)
			60	2.10	0.40	19	+20, -10	
		110	60	2.32	0.46	23	+10, -15	
	B	110	50	2.20	0.47	22	+10, -15	
			60	2.00	0.36	21	+15, -10	
		120	60	2.10	0.42	23	+10, -15	
	V	200	50	1.21	0.26	22	+10, -15	
			60	1.05	0.20	19	+20, -10	
		220	60	1.16	0.23	23	+10, -15	
	D	220	50	1.10	0.24	22	+10, -15	
			60	1.00	0.18	21	+15, -10	
		240	60	1.05	0.21	23	+10, -15	
DC	G	12	—	—	2.36	29	±10	H (180°C)
	H	24	—	—	1.16	28		
	R	100	—	—	0.29	29		
AC ↓ DC (AC/DC conversion) (ADC)	TR	AC100 V 50/60 Hz ↓ DC90 V (coil)		—	0.33	30	±10	H (180°C)
	BR	AC110 V 50/60 Hz ↓ DC100 V (coil)		—	0.29	29		
	VR	AC200 V 50/60 Hz ↓ DC180 V (coil)		—	0.17	31		

- Note:
- Current values and power consumption varies with temperature conditions. Values shown in table are based on 30°C.
 - In the AC/DC conversion type, AC power is used to activate the DC solenoid by the built-in rectifier, and it comes with the characteristics featured by DC solenoids. This means that the items given for the DC solenoids apply for the maximum flow.
 - Consult Tokyo Keiki for details on solenoids for the supply voltages which are not listed above.

E
2-2

Directional Control Valves

Spool Types (Neutral Position)

Spool Types	Name	Functional Symbol	Spool Configuration Diagram	Functions and Applications
0	Open center			At the neutral position the pump is set to the unload status and the actuator to the floating status. In the case of the 2-position type, all the ports are connected to the tank during the course of switching so shock is reduced.
1	P-A-T connected			The valve is used when, at the neutral position, the pump is to be set to the unload status and the pressure oil is to be sent only in one direction, and the actuator is to be kept shut down.
2	Closed center			At the neutral position the pump pressure is maintained, and the actuator is locked. It must be borne in mind that all the ports are blocked during the course of switching so shock will be generated in the case of the 2-position type.
3	A-T connected			Slight movements in one direction of the actuator caused by leaks from the P port at the neutral position are prevented.
6	A-B-T connected			At the neutral position the pump pressure is maintained, and the actuator is set to the floating status. As is the case with spool type "2," the 2-position type is used when the pump pressure is to be maintained even during the course of switching. Shocks arise during the course of switching as well, but the shocks are less compared with spool type "2."
7	P-A-B connected			At the neutral position a differential circuit can be configured.
8	Tandem			At the neutral position the pump is set to the unload status, and the actuator is locked. A multiple number of the valves can be connected in series for use.
33	A-B-T connected w/restrictors			This type, which is a modified version of spool type "6," was created by adding restrictors between the A → T and B → T ports. The restrictors serve as brakes so when the actuator is to be shut down, it can be shut down faster than is the case with spool type "6."

Comparison of representative spool types

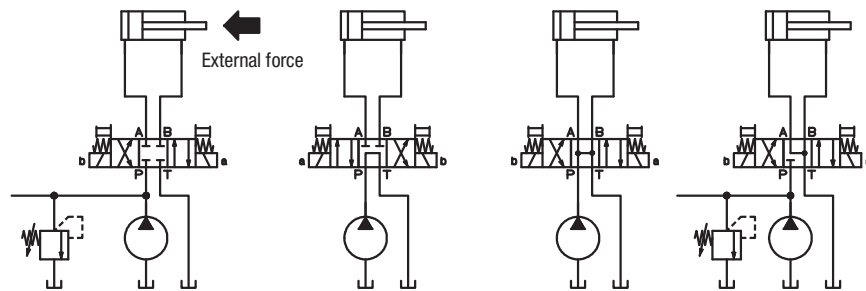

Spool Types	2	8	0	6
Name	Closed center	Tandem	Open center	A-B-T connected
Pump status	Pressure maintained	Unload	Unload	Pressure maintained
Actuator status	Locked	Locked	Floating	Floating

Spool Types and Pressure-Flow Characteristics

AC Solenoid (applied voltage is 90% of rated, frequency is 60 Hz)

Spool Center Position	Model Code, Functional Symbol			Max. Flow L/min														
	3 Position	2 Position		P → A → B → T					P → A (B port block)					P → B (A port block)				
	Spring Centered - C -	Spring Offset, B Type																
		- B -	- BL -	7MPa	14MPa	21MPa	28MPa	35MPa	7MPa	14MPa	21MPa	28MPa	35MPa	7MPa	14MPa	21MPa	28MPa	35MPa
0	 DG4V-3-0C 	DG4V-3-0B 	DG4V-3-0BL 	80	80	80	80	80	80	80	80	80	80	80	80	80	80	80
1	 DG4V-3-1C 	DG4V-3-1B 	DG4V-3-1BL 	45	45	45	30	25	70 (40)	25 (20)	20 (14)	20 (11)	18 (10)	45	45	45	45	45
2	 DG4V-3-2C 	DG4V-3-2B 	DG4V-3-2BL 	100	100	100	100	100	80	32	20	15	10	80	32	20	15	10
3	 DG4V-3-3C 	DG4V-3-3B 	DG4V-3-3BL 	80	80	50	20	10	80	22	10	5	5	80	26	18	10	5
6	 DG4V-3-6C 	DG4V-3-6B 	DG4V-3-6BL 	80	80	80	80	80	80	34	23	16	10	80	34	23	16	10
7	 DG4V-3-7C 	DG4V-3-7B 	DG4V-3-7BL 	100	100	100	100	100	70	21	14	12	10	70	21	14	12	10
8	 DG4V-3-8C 	DG4V-3-8B 	DG4V-3-8BL 	45	45	45	30	25	45 (45)	45 (45)	45 (38)	30 (33)	25 (30)	45	45	45	30	25
22	 DG4V-3-22C 	DG4V-3-22B 	DG4V-3-22BL 	—	—	—	—	—	80	20	10	5	5	80	20	10	5	5
31	 DG4V-3-31C 	DG4V-3-31B 	DG4V-3-31BL 	80	80	50	20	10	80	26	18	10	5	80	22	10	5	5
33 34	 DG4V-3-33/34C 	DG4V-3-33/34B 	DG4V-3-33/34BL 	80	80	80	80	80	80	32	20	15	10	80	32	20	15	10
52	 DG4V-3-52C 		DG4V-3-52BL 	80	80	80	10	5	80	20	10	8	5	80	20	10	8	5
56	 DG4V-3-56C 		DG4V-3-56BL 	80	80	80	10	5	80	20	10	8	5	80	20	10	8	5
62	 DG4V-3-62C 		DG4V-3-62BL 	80	80	80	10	5	80	25	20	15	10	80	25	20	15	10
63	 DG4V-3-63C 	DG4V-3-63B 		—	—	—	—	—	80	25	20	15	10	80	25	20	15	10
521	 DG4V-3-521C 	DG4V-3-521B 		80	80	80	10	5	80	20	10	8	5	80	20	10	8	5
561	 DG4V-3-561C 	DG4V-3-561B 		80	80	80	10	5	80	20	10	8	5	80	20	10	8	5
621	 DG4V-3-621C 			80	80	80	10	5	80	25	20	15	10	80	25	20	15	10

Note: • Values in () for spool types 1 and 8 are max. flows with A, B ports blocked.
• Max. flow refers to limit flow without valve malfunction for valve switching.

Spool Types and Pressure-Flow Characteristics

AC Solenoid (applied voltage is 90% of rated, frequency is 60 Hz)

Spool Transient Condition	Model Code, Functional Symbol			Max. Flow L/min														
	2 Position			N, A, AL					N, A		AL			N, A			AL	
	No Spring Detented	Spring Offset, A Type																
		- N -	- A -	- AL -	7MPa	14MPa	21MPa	28MPa	35MPa	7MPa	14MPa	21MPa	28MPa	35MPa	7MPa	14MPa	21MPa	28MPa
0	DG4V-3-0A 	DG4V-3-0AL 		80	80	80	80	80	60	60	60	60	60	80	80	80	80	80
	DG4V-3-0N 			70	70	70	70	70	60	60	60	60	60	60	60	60	60	60
2	DG4V-3-2A 	DG4V-3-2AL 		80	80	75	55	50	50	15	10	10	10	55	35	33	30	30
	DG4V-3-22A 	DG4V-3-22AL 		—	—	—	—	—	40	20	15	10	10	80	50	30	18	10
	DG4V-3-23A 	DG4V-3-23AL 		80	80	80	80	80	40	20	15	10	10	—	—	—	—	—
	DG4V-3-26A 	DG4V-3-26AL 		—	—	—	—	—	—	—	—	—	—	—	—	—	—	—
	DG4V-3-28A 	DG4V-3-28AL 		80	80	80	80	80	40	18	15	10	10	80	55	35	30	25
	DG4V-3-32A 	DG4V-3-32AL 		65	65	65	65	65	60	20	15	10	10	80	25	15	10	5
	DG4V-3-35A 	DG4V-3-35AL 		—	—	—	—	—	80	80	45	42	35	—	—	—	—	—
	DG4V-3-2N 			70	70	70	70	70	60	60	60	50	30	60	60	60	50	30
6	DG4V-3-6A 	DG4V-3-6AL 		80	80	80	80	80	40	20	15	10	10	80	35	30	25	25
	DG4V-3-6N 			80	80	80	80	80	50	50	50	50	50	50	50	50	50	50
7	DG4V-3-7A 	DG4V-3-7AL 		50	50	50	50	50	50	25	15	10	10	70	25	20	15	10
	DG4V-3-27A 	DG4V-3-27AL 		—	—	—	—	—	80	25	15	15	15	80	50	45	40	40
24	DG4V-3-24A 	DG4V-3-24AL 		60	60	60	60	60	60	25	15	10	10	—	—	—	—	—

Note: Max. flow refers to limit flow without valve malfunction for valve switching.

E
2-5

Directional Control Valves

Spool Types and Pressure-Flow Characteristics

DC, AC-DC Rectifier Solenoid (applied voltage 90% of rated)

E
2-6
Directional Control Valves

Spool Center Position	Model Code, Functional Symbol			Max. Flow L/min														
	3 Position	2 Position		P → A → B → T					P → A (B port block)					P → B (A port block)				
	Spring Centered - C -	Spring Offset, B Type																
		- B -	- BL -	7MPa	14MPa	21MPa	28MPa	35MPa	7MPa	14MPa	21MPa	28MPa	35MPa	7MPa	14MPa	21MPa	28MPa	35MPa
0	DG4V-3-0C	DG4V-3-0B	DG4V-3-0BL	80	80	80	80	80	80	80	80	80	80	80	80	80	80	80
1	DG4V-3-1C	DG4V-3-1B	DG4V-3-1BL	45	45	45	30	25	70 (40)	25 (20)	20 (14)	20 (11)	18 (10)	45	45	45	45	45
2	DG4V-3-2C	DG4V-3-2B	DG4V-3-2BL	100	100	100	100	100	80	45	30	23	19	80	45	30	23	19
3	DG4V-3-3C	DG4V-3-3B	DG4V-3-3BL	80	80	65	35	30	80	30	23	18	14	80	65	35	28	24
6	DG4V-3-6C	DG4V-3-6B	DG4V-3-6BL	80	80	80	52	42	80	60	38	27	23	80	60	38	27	23
7	DG4V-3-7C	DG4V-3-7B	DG4V-3-7BL	100	100	100	100	100	70	21	14	12	10	70	21	14	12	10
8	DG4V-3-8C	DG4V-3-8B	DG4V-3-8BL	45	45	45	30	25	45 (45)	45 (45)	45 (38)	30 (33)	25 (30)	45	45	45	30	25
22	DG4V-3-22C	DG4V-3-22B	DG4V-3-22BL	—	—	—	—	—	80	34	25	20	20	80	34	25	20	20
31	DG4V-3-31C	DG4V-3-31B	DG4V-3-31BL	80	80	65	35	30	80	65	35	28	24	80	30	23	18	14
33 34	DG4V-3-33/34C	DG4V-3-33/34B	DG4V-3-33/34BL	80	80	80	80	80	80	45	30	23	19	80	45	30	23	19
52	DG4V-3-52C		DG4V-3-52BL	80	80	40	27	22	80	37	25	20	20	80	37	25	20	20
56	DG4V-3-56C		DG4V-3-56BL	80	80	40	27	22	80	37	25	20	20	80	37	25	20	20
62	DG4V-3-62C		DG4V-3-62BL	80	80	40	27	22	80	37	25	20	20	80	37	25	20	20
63	DG4V-3-63C	DG4V-3-63B		—	—	—	—	—	80	37	25	20	20	80	37	25	20	20
521	DG4V-3-521C	DG4V-3-521B		80	80	40	27	22	80	37	25	20	20	80	37	25	20	20
561	DG4V-3-561C	DG4V-3-561B		80	80	40	27	22	80	37	25	20	20	80	37	25	20	20
621	DG4V-3-621C			80	80	40	27	22	80	37	25	20	20	80	37	25	20	20

Note: • Values in () for spool types 1 and 8 are max. flows with A, B ports blocked.
 • Max. flow refers to limit flow without valve malfunction for valve switching.
 • For KU4 coil, it may differ from this table.

Spool Types and Pressure-Flow Characteristics

DC, AC-DC Rectifier Solenoid (applied voltage 90% of rated)

Spool Transient Condition	Model Code, Functional Symbol		Max. Flow L/min															
	2 Position		N, A, AL					N, A			AL			N, A			AL	
	No Spring Detected	Spring Offset, A Type																
		7MPa	14MPa	21MPa	28MPa	35MPa	7MPa	14MPa	21MPa	28MPa	35MPa	7MPa	14MPa	21MPa	28MPa	35MPa		
0	DG4V-3-0A	DG4V-3-0AL	80	80	80	80	80	60	60	60	60	60	80	80	80	80	80	
	DG4V-3-0N		70	70	70	70	70	60	60	60	60	60	60	60	60	60	60	
2	DG4V-3-2A	DG4V-3-2AL	80	80	80	63	60	50	15	10	10	10	80	40	26	22	20	
	DG4V-3-22A	DG4V-3-22AL	—	—	—	—	—	40	20	15	10	10	80	50	30	25	20	
	DG4V-3-23A	DG4V-3-23AL	80	80	80	80	80	40	20	15	10	10	—	—	—	—	—	
	DG4V-3-26A	DG4V-3-26AL	—	—	—	—	—	—	—	—	—	—	—	—	—	—	—	
	DG4V-3-28A	DG4V-3-28AL	80	80	80	80	80	40	18	15	10	10	80	55	35	25	25	
	DG4V-3-32A	DG4V-3-32AL	65	65	65	65	65	60	20	15	10	10	80	40	30	25	20	
	DG4V-3-35A	DG4V-3-35AL	—	—	—	—	—	80	80	45	42	35	—	—	—	—	—	
DG4V-3-2N		70	70	70	70	70	60	60	60	50	30	60	60	60	50	30		
6	DG4V-3-6A	DG4V-3-6AL	80	80	80	80	80	40	20	15	10	10	80	40	35	30	30	
	DG4V-3-6N		80	80	80	80	80	50	50	50	50	50	50	50	50	50	50	
7	DG4V-3-7A	DG4V-3-7AL	50	50	50	50	50	50	25	15	10	10	80	27	17	12	10	
	DG4V-3-27A	DG4V-3-27AL	—	—	—	—	—	80	25	15	15	15	80	50	45	40	40	
24	DG4V-3-24A	DG4V-3-24AL	60	60	60	60	60	60	25	15	10	10	—	—	—	—	—	

Note: • Max. flow refers to limit flow without valve malfunction for valve switching.
 • For KU4 coil, it may differ from this table.

Characteristics Curve (viscosity 20 mm²/s, specific gravity 0.87) (typical examples)

Pressure Drop Characteristics

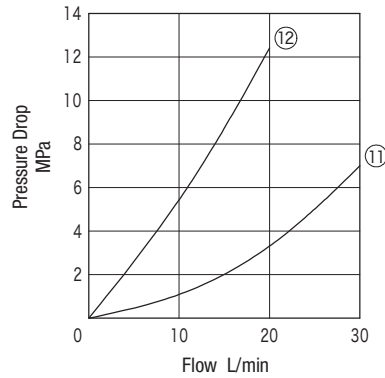
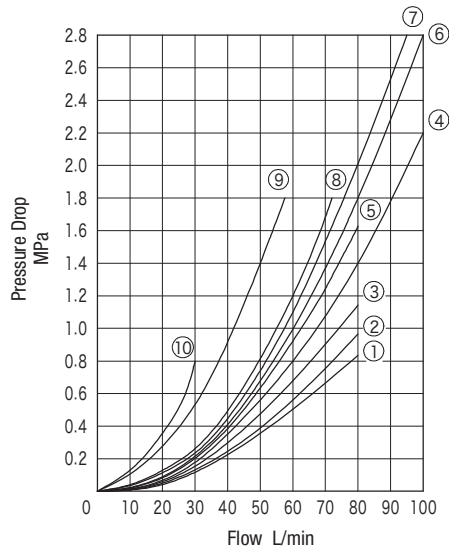

1. For pressure drops (ΔP_1) of viscosities other than 20 mm²/s, calculate using multiplier coefficients shown in below table.
2. The formula to calculate pressure drops (ΔP_1) for specific gravities other than 0.87 is as follows.
 $\Delta P_1 = \Delta P \times G_1 / G$
 ΔPValues according to characteristics curve
 G 0.87
 G_1Desired specific gravity value

Viscosity mm ² /s	10	20	30	40	50	60	70	80	90	100	110	120	130	140	150
Coefficient	0.85	1.00	1.09	1.17	1.24	1.29	1.34	1.38	1.42	1.46	1.49	1.52	1.56	1.59	1.62

Pressure Drop Curve Number

Spool Type	C, B, BL									A, AL				N					
	Switched Condition				Neutral Condition					Spool Type	Switched Condition			Spool Type	Switched Condition				
	P ↓ A	B ↓ T	P ↓ B	A ↓ T	P ↓ T	A ↓ T	B ↓ T	P ↓ A	P ↓ B		P ↓ A	B ↓ T	P ↓ B		A ↓ T	P ↓ B	A ↓ T		
0	④	③	④	③	④	①	①	④	④	0	⑤	④	⑤	④	0	④	③	④	③
1	④	③	④	③	⑧	②	—	④	—	2	⑦	⑥	⑦	⑧	2	⑦	④	⑦	④
2	⑥	④	⑥	④	—	—	—	—	—	6	⑦	④	⑧	④	6	⑧	②	⑧	②
3	⑥	④	⑧	②	—	④	—	—	—	7	⑤	⑧	⑤	⑨	—	—	—	—	—
6	⑧	②	⑧	②	—	④	④	—	—	22	⑥	—	⑦	—	—	—	—	—	—
7	④	⑥	④	⑥	—	—	—	⑦	⑦	23	⑦	⑤	—	⑦	—	—	—	—	—
8	⑦	⑤	⑦	⑤	⑧	—	—	—	—	24	⑦	④	⑦	④	—	—	—	—	—
22	⑦	—	⑦	—	—	—	—	—	—	26	—	④	—	⑥	—	—	—	—	—
31	⑧	②	⑥	④	—	—	④	—	—	27	⑤	—	⑤	—	—	—	—	—	—
33	⑥	④	⑥	④	—	⑫	⑫	—	—	28	⑦	—	⑧	⑦	—	—	—	—	—
34	⑥	④	⑥	④	—	⑪	⑪	—	—	32	⑦	⑤	⑧	—	—	—	—	—	—
52	⑦	—	⑦	③	—	—	—	—	—	35	⑦	④	—	—	—	—	—	—	—
56	⑥	—	②	③	—	⑩	⑧	—	—	—	—	—	—	—	—	—	—	—	—
62	⑧	—	⑧	②	—	④	⑥	—	—	—	—	—	—	—	—	—	—	—	—
63	⑧	—	⑧	—	—	⑥	⑥	—	—	—	—	—	—	—	—	—	—	—	—
521	⑦	③	⑦	—	—	—	—	—	—	—	—	—	—	—	—	—	—	—	—
561	⑦	③	⑦	—	—	⑧	⑩	—	—	—	—	—	—	—	—	—	—	—	—
621	⑧	②	⑧	—	—	⑥	④	—	—	—	—	—	—	—	—	—	—	—	—

Switching Times

Power Supply	Operation	De-energize Time	Unit: ms		
			Spring Offset Spring Centered C, B, BL	Spring Offset A, AL	No Spring Detented N
AC	Energize	/	10~15		10~15
	Spring Return		20		
DC	Energize		30		30
	Spring Return		15 * (90)		
AC/DC conversion with Rectifier	Energize			30	30
	Spring Return		Fast	20	
		Slow	90		

Conditions: No. 2 spool, open loop circuit, flow 40 L/min., supply pressure 17.5 MPa, fluid viscosity 20 mm²/s

[Circuit Example]

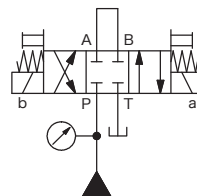

[Switching Time Definition]

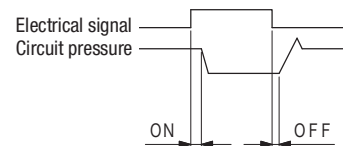

Note: • Values shown may vary according to spool type and circuit conditions.
 • * Indicates KU4 coil.

Notes on Operation

- **Mounting orientation**
To ensure sure switching of no spring detented type valves, mount valves so spool axis is horizontal. There are no mounting attitude restrictions for other spool/spring arrangements.
- **Solenoid energization**
Always ensure that one side of solenoid is deenergized before energizing the opposite side. For spring centered and spring offset valves, solenoid should be continuously energized during circuit switching. Deenergization of solenoid will cause spool to return to prescribed position by spring force. For no spring detented type valves, spool will be maintained in switched position by the detent but to ensure sure circuit switching, solenoid should be energized for more than 0.1 second.
- **T (tank) port piping**
Prevent abnormal pressure surges above the allowable back pressure rating from being generated in T port. Valve is wet armature type so ensure that valve is always filled with oil.
- **Using valves as two-way and three-way**
Valve is designed as four-way and max. flow is limited when using as two or three-way valves. Consult Tokyo Keiki for details.
- **Long periods of solenoid energization**
Care should be paid as long periods of solenoid energization at high pressure may cause spool sticking and switching malfunction.
- **Malfunctions due to surge pressure**
Avoid combining flows of tank lines prone to surge pressures. Surge pressures in T port may lead to spool malfunctions. No spring detented type valves are susceptible to such malfunctions during deenergization.
- **Manual operation**
For manual switching, push the manual override pin. Be aware that actuation force increases with higher back pressure. (See graph)

- **Solenoid indicator lamp**
For valves with indicator lamps, the lamps will light when current flows to the solenoid.
- **Electrical wiring**
Solenoid and conduit box are pre-wired. Refer to below diagrams for wiring from power source to conduit box and DIN connectors.

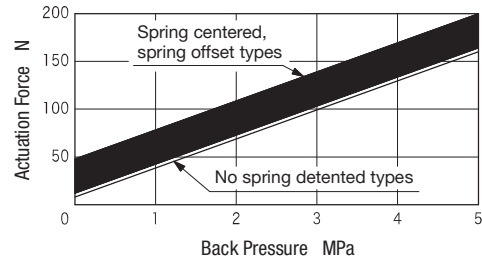
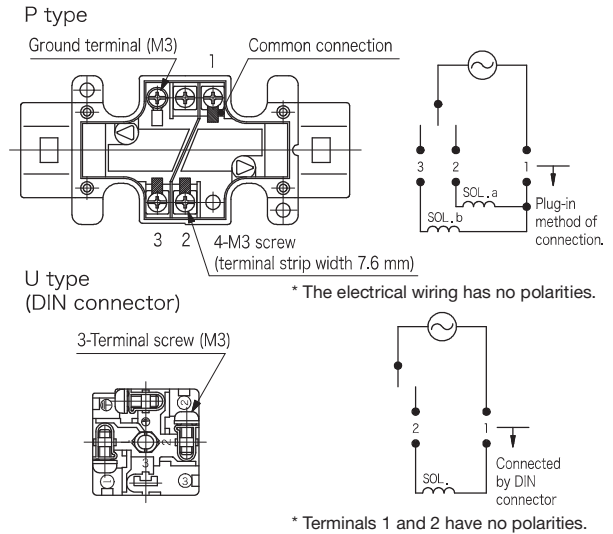

Mounting Bolts (JIS B 1176, Strength Class 12.9)

Hex Socket Bolts	Qty
M5 × 50	4

- Mounting bolts must be ordered separately.
- Tightening torque of mounting bolts: 7 to 8 N•m

● Mounting dimensions

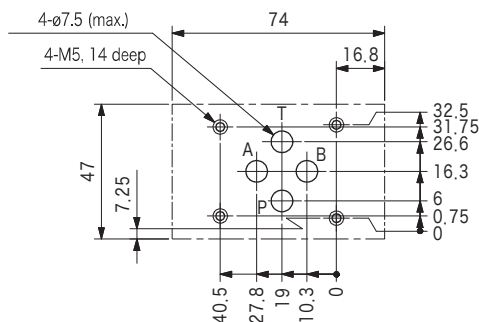

Subplate

Subplate		Connection Port Dia. Rc
Side Piping	DGMS-3-1E-10-T-JA-J	3/8
Bottom Piping	DGVM-3-10-T-JA-J	

- Subplate and bolts must be ordered separately.
- See page R6-6 for dimensions.
- See page R6-6 for plural mount subplates.
- Max. working pressure is 21 MPa. For higher pressures, valve should be mounted on manifold block.

● Mounting surface machining accuracy

Surface Roughness	1.6 μ m Ra	
Flatness	Less than 0.01 (\square per 100 mm)	
Permissible Tolerance	Mounting bolt hole: ± 0.1 Ports: ± 0.2	

Dimensions

● AC solenoid

Spring Offset DG4V-3-*A/B-M-P* (solid line)

Spring Offset DG4V-3-*AL/BL-M-P* (dashed line)

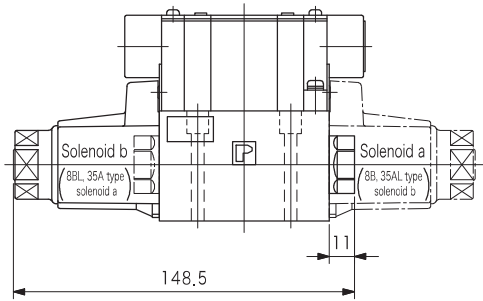

E
2-10

Directional Control Valves

Spring Centered DG4V-3-*C-M-P*

No Spring Detented DG4V-3-*N-M-P*

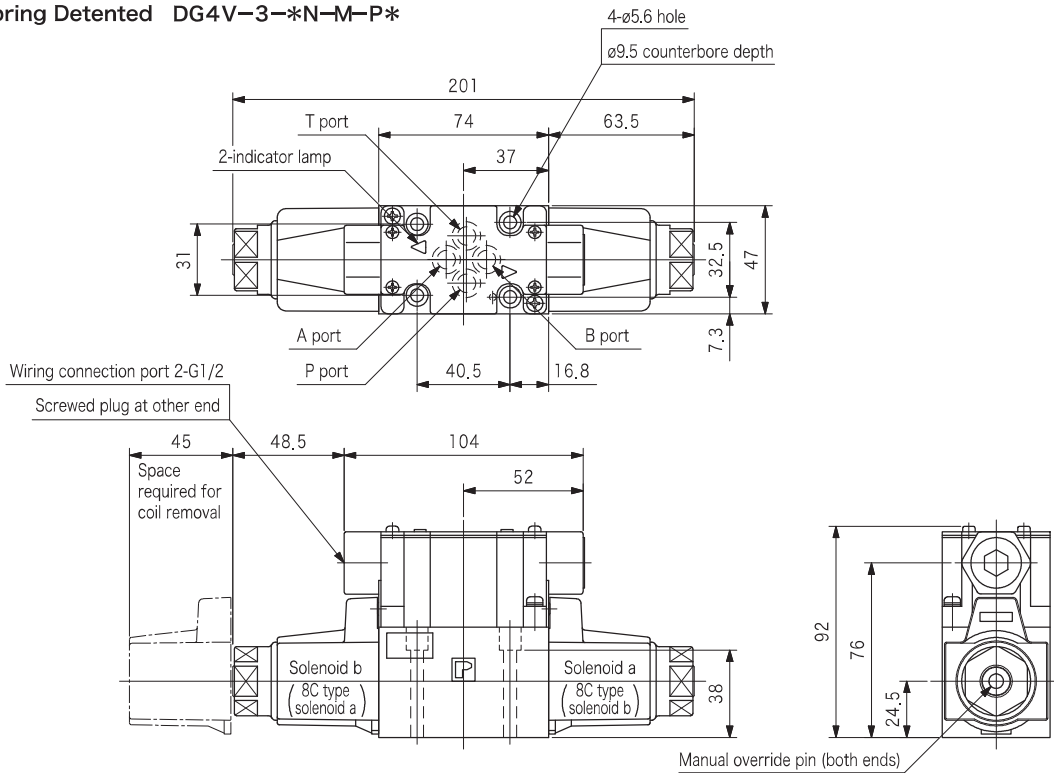

DG4V-3-*C/N-M-U*

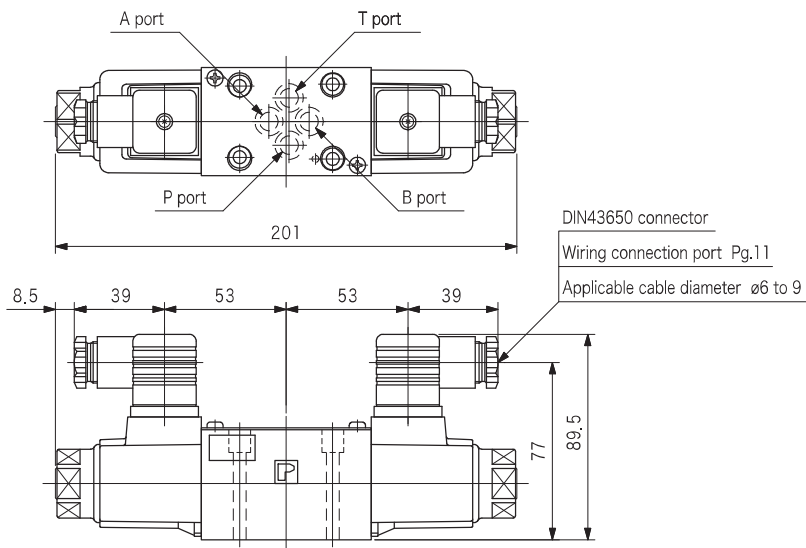

Dimensions

● DC solenoid

Spring Offset DG4V-3-*A/B-M-P* (solid line)

Spring Offset DG4V-3-*AL/BL-M-P* (dashed line)

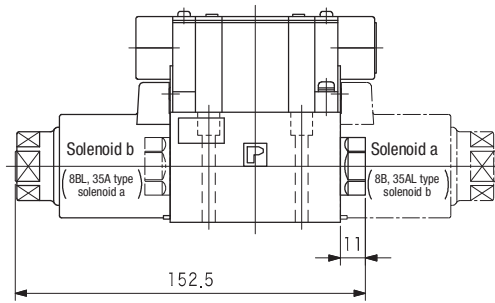

Spring Centered DG4V-3-*C-M-P*

No Spring Detented DG4V-3-*N-M-P*

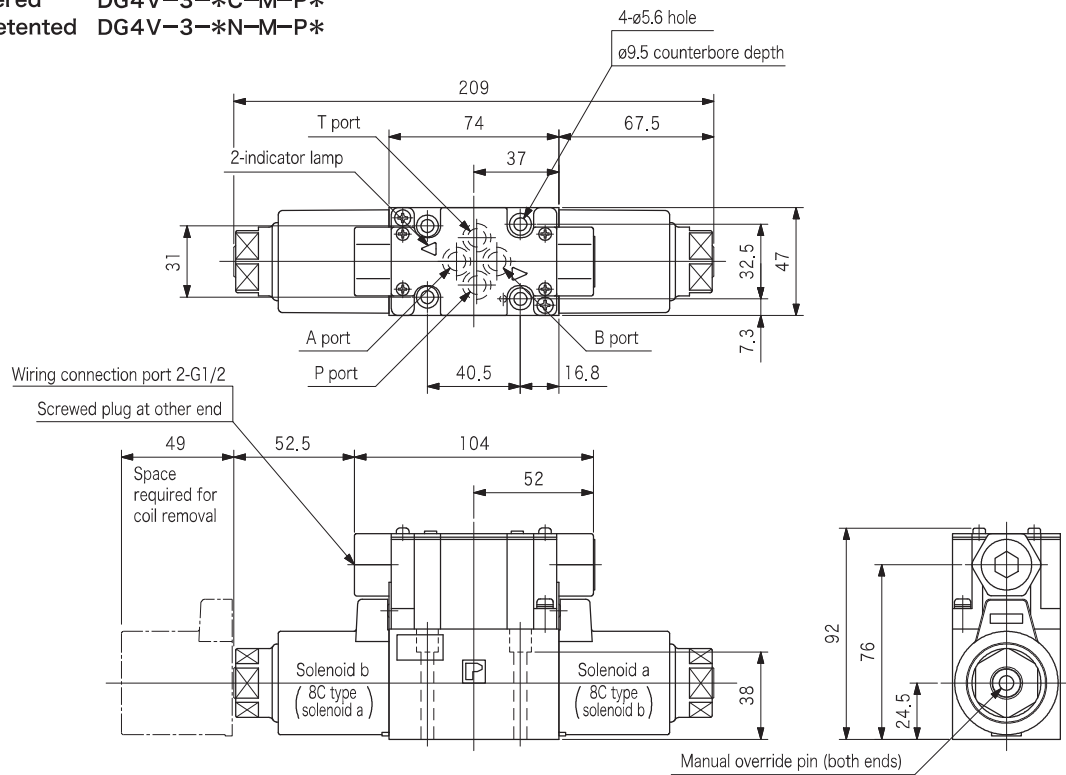

DG4V-3-*C/N-M-U*

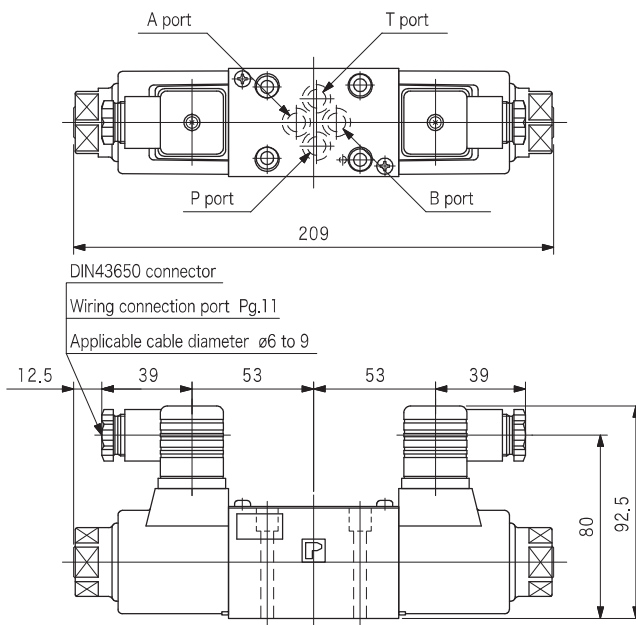

DG4V-3-*C/N-M-KU*

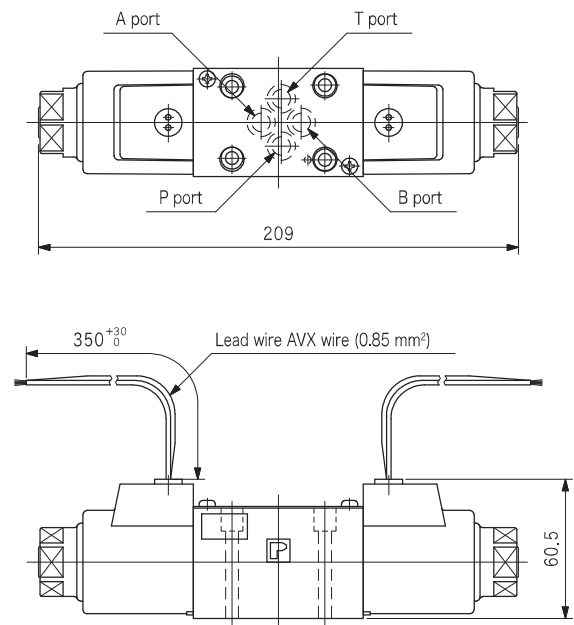

Construction

O-ring

No.	Part No.	Standard	Qty	
			A/B	C/N
2	008001817	JIS B 2401 1A-P20	1	2
4	008000217	JIS B 2401 1A-P4	2	4
5	007902617	AS568-026 (NBR, Hs70)	1	2
7	007911429	AS568-114 (FKM, Hs90)	1	2
12	007901219	AS568-012 (NBR, Hs90)	4	4
18	007911419	AS568-114 (NBR, Hs90)	1	—
27	007900817	AS568-008 (NBR, Hs70)	1	1

Solenoid coil (P type)

No.	Voltage Code	Part No.
3	T	40078310
	B	40078311
	V	40078312
	D	40078313
	G	40078304
	H	40078305
	R	40078307
	TR	40078308
	BR	40078307
VR	40078309	

P Type

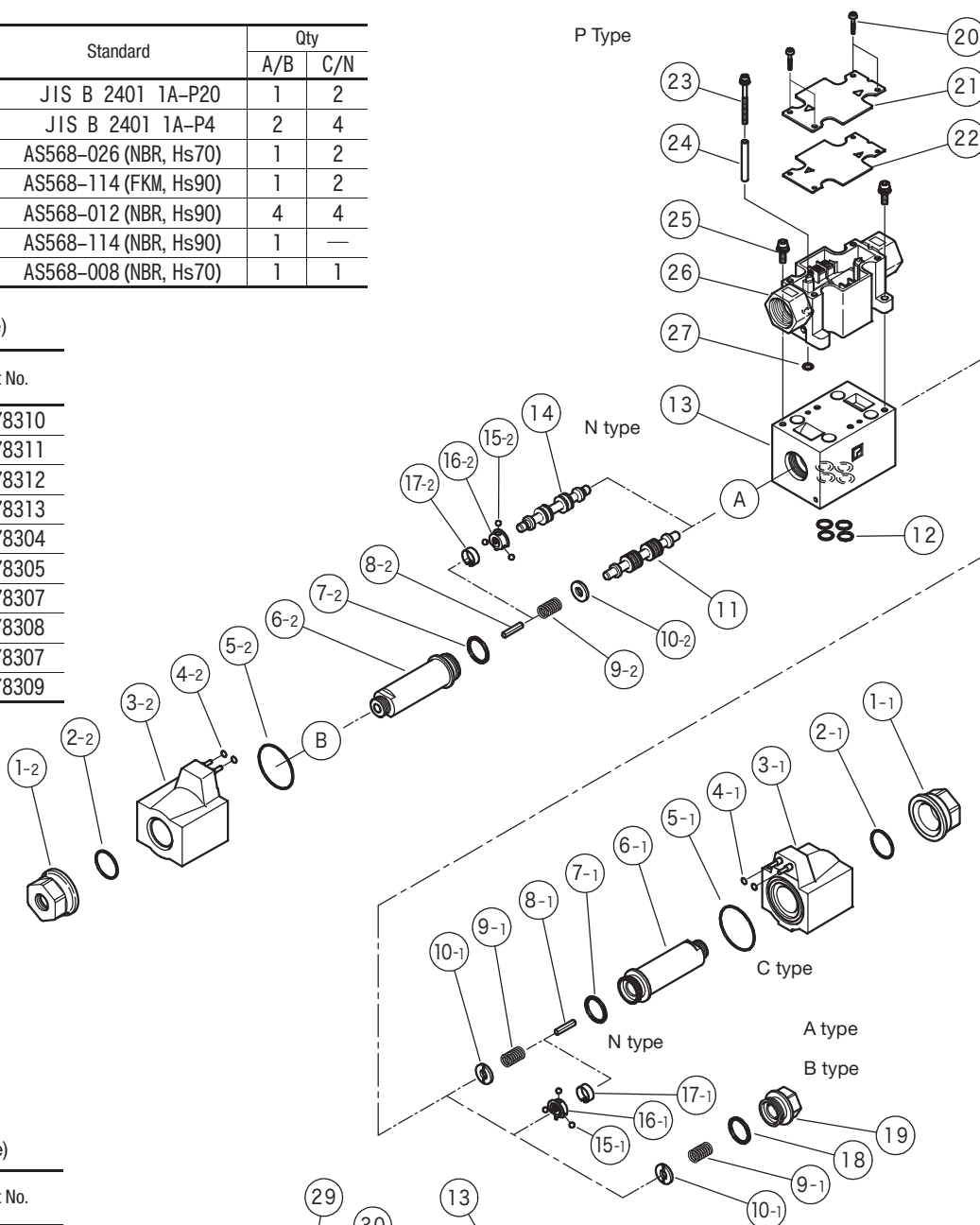

Solenoid coil (U type)

No.	Voltage Code	Part No.
28	T	40078320
	B	40078321
	V	40078322
	D	40078323
	G	40078314
	H	40078315
	R	40078317
	TR	40078318
	BR	40078317
VR	40078319	

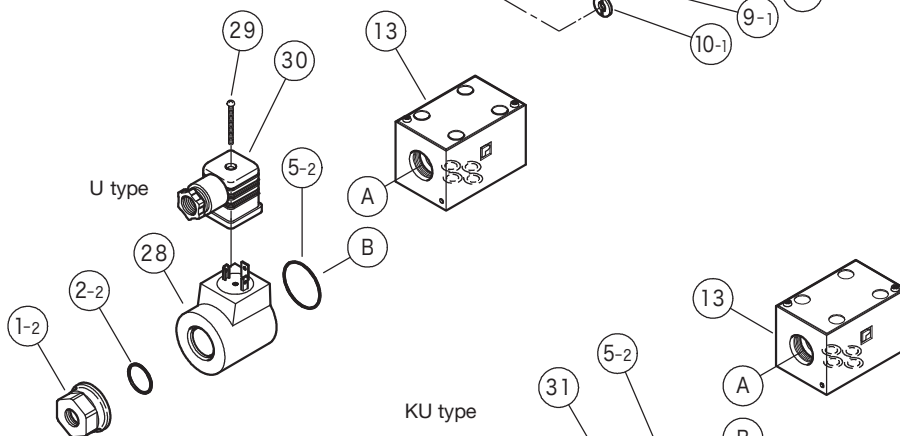

Solenoid coil (KU type)

No.	Electrical Accessories, Voltage Code	Part No.
31	KU-G	40078324
	KU-H	40078325
	KU4-G	40078326
	KU4-H	40078327

KU type

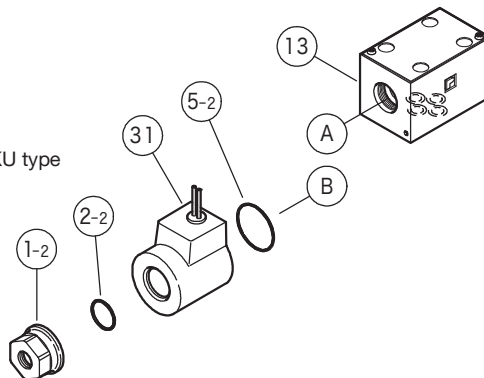

E
2-12

Directional Control Valves