



Solenoid Valve

3Port Valve/PHS320	P.438
5Port Valve/PHS500	P.442
5Port Valve/PHS510	P.449
5Port Valve/PHS520	P.456
5Port Valve/PHS530	P.463
5Port Valve/PHS540	P.470

NAMUR Valve

5Port Valve/34○Y	P.481
------------------	-------

Air Operated Valve

5Port Valve/PHS520	P.488
5Port Valve/PHS530	P.489
5Port Valve/PHS540	P.490

PHS Series

3Port Solenoid Valve

PHS 320 Series _____ P. 438

5Port Solenoid Valve

M5 Port/PHS 500 Series _____ P. 442

1/8 Port/PHS 510 Series _____ P. 449

1/4 Port/PHS 520 Series _____ P. 456

3/8 Port/PHS 530 Series _____ P. 463

1/2 Port/PHS 541 Series _____ P. 470

1/2 Port/PHS 540 Series _____ P. 475



3Port Pilot Operated Solenoid Valve

PHS320 Series

Rubber Seal / In-Line type

PHS320S 3/2 Way
N-C/N-O Common

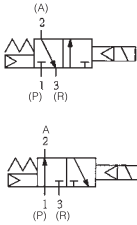

Specification

Item	Unit	PHS320S
Fluid		Non-Lubricated/Lubricated Air
Port Size	Rc(PT)	1/4
Effective Area	mm ² (Cv)	23 (1.3)
Operating Temperature	°C	5 ~ 60
Pressure Range	MPa(bar)	0.15~0.9 (1.5~9.0)
Max. Operating Cycle	cycle/s	10
Response Time	ms	Less than 20
Exhaust type		individual Exhaust
Manual Override		Non-Lock/Lever-Lock
Shock/Vibration Resistance		30G~5G (8.3~200Hz)

Electrical Specification

Voltage	V	DC24V, AC110V, AC220V(50~60Hz)
Allowable Voltage Fluctuation	%	± 10%
Power Consumption	W, VA	DC24V(2.5W), AC110/220V 50Hz(6VA)/60Hz(4.9VA)
Insulation Class		F Class
Wiring		lead Wire, DIN Connector
Indicate lamp		LED

Order Key

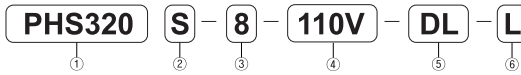

1. Series

3Port Solenoid Valve
N · C/N · O common use

2. Function

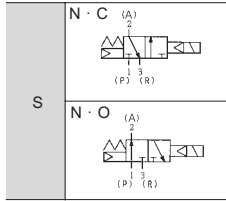

Note) Possible to use N.O type by rotating body cover.
Offer N.C type initially.

3. Port Size

8	PT 1/4"
---	---------

Note) Basically PHS320 series are assembled N-C

4. Voltage

24V	DC24V
110V	AC110V
220V	AC220V

5. Wiring

No mark	Lead wire
D	DIN connector.
DL	DIN connector, Indicator lamp.
DS	DIN connector, Indicator lamp, Surge protection.

6. Manual

No mark	Non-Lock
L	Lever Lock

Coil and Connector

Coil



Voltage		Wiring	
24V	DC24	No mark	Lead wire
110V	AC 110V	D	DIN Connector
220V	AC 220V		

Note) Please order the connector together
When you order DIN connector type coil.

Connector



Indicator lamp		Voltage	
No mark	w/o Lamp	24V	DC24
L	with Lamp	110V	AC 110V
S	Surge suppressor Indicator lamp	220V	AC 220V

PHS320 Series

Dimension

(Unit: mm)

PHS320

Lead Wire Type

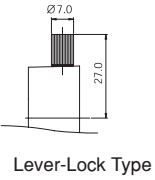
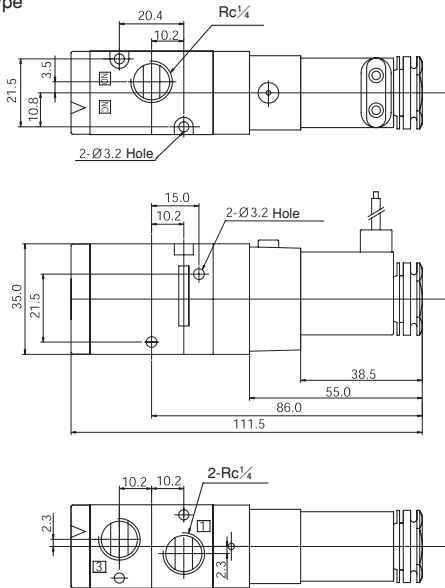

DIN Connector Type

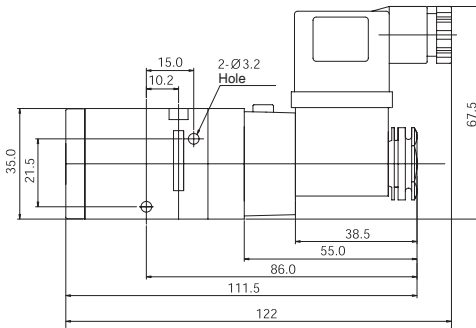

Construction

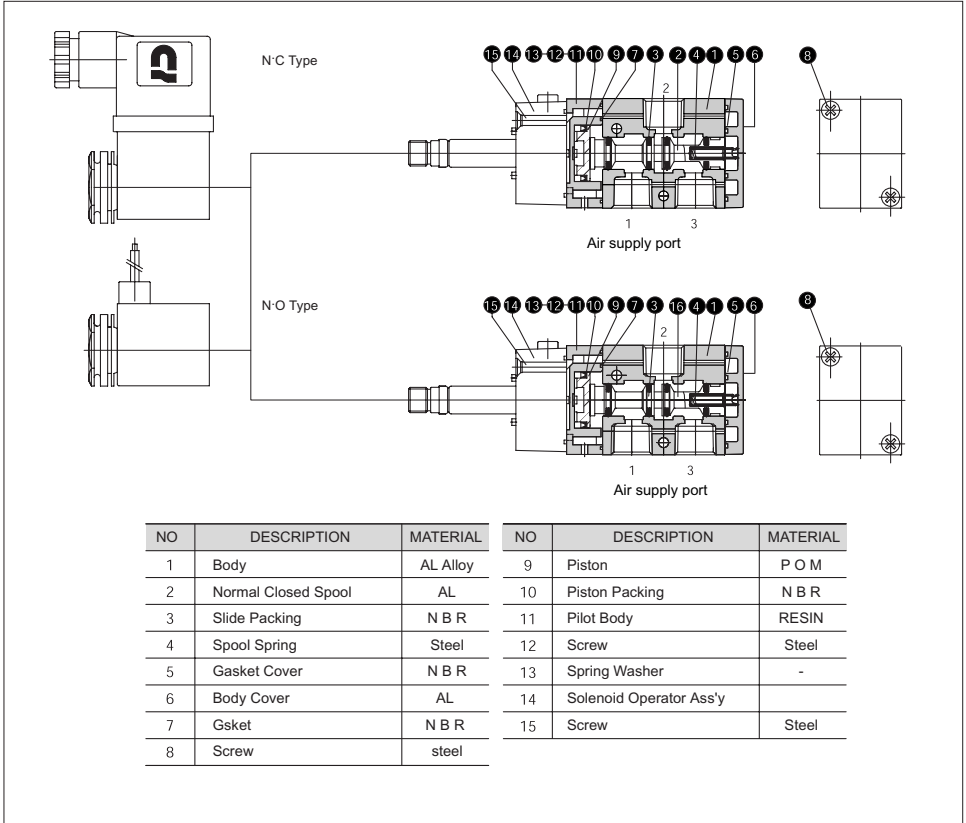

Port Change from N-O to N-C

End Vover must be rotated 180°
And Air supply port must be changed as below table.

Port Identification

Function	N-C type	N-O type
Port No. 1	Air Supply	Exhaust
Port No. 2	Cylinder	Cylinder
Port No. 3	Exhaust	Air Supply

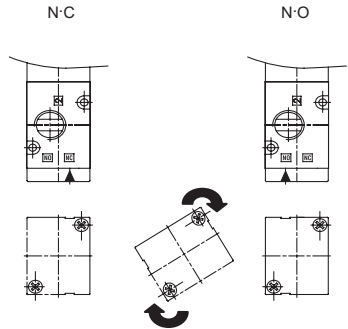

5Port Pilot Operated Solenoid Valve

PHS500 Series

Rubber Seal / In-Line type

PHS500S 2 Position
Single Solenoid

PHS500D 2 Position
Double Solenoid

PHS500C 3 Position
Center closed

PHS500E 3 Position
Exhaust center

PHS500P 3 Position
Pressure center



Specification

Item	Unit	PHS500S	PSH500D	PHS500C	PHS500E	PHS500P
Fluid		Non-Lubricated/Lubricated Air				
Port Size	M	M5				
Effective Area	mm ²	3.6		3.0		
Operating Temperature	°C	5 ~ 60				
Pressure Range	MPa(bar)	0.15 ~ 1.0 (1.5 ~ 10.0)		0.2 ~ 1.0 (2.0 ~ 10.0)		
Max. Operating Cycle	cycle/s	5		3		
Response Time	ms	25 less		35 less		
Exhaust type		Individual Exhaust				
Manual Override		Non-Lock(standard)/Lever-Lock(option)				
Shock/Vibration Resistance	m/s ²	30G~5G (8.3~200Hz)				
Voltage	V	DC24V, AC110V, AC220V(50 ~60Hz)				
Allowable Voltage Fluctuation	%	AC : ±20% / DC : ±10%				
Power Consumption	W, VA	DC : 2.5W, AC : 3.5VA (60Hz)				
Insulation Class		F Class				
Wiring		Lead Wire, DIN Connector				
Indicate Lamp		LED				

ORDER KEY

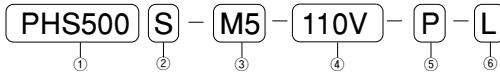

1. Series

5 Port Solenoid Valve

2. Function

S	<p>Single Solenoid</p>
D	<p>Double Solenoid</p>
C	<p>Center Closed</p>
E	<p>Exhaust Center</p>
P	<p>Pressure Center</p>

3. Port Size

M5	M5 × 0.8
----	----------

4. Voltage

24V	DC24V
110V	AC110V
220V	AC220V

5. Wiring

No mark	Lead Wire
P	Horizontal Connector
V	Perpendicular Connector

6. Manual Override

No mark	Non-Lock
L	Lever-Lock

Coil & Connector

Coil

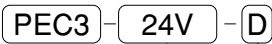

Voltage

24V	DC24
110V	AC 110V
220V	AC 220V

Wiring

No mark	Lead wire
D	DIN

Connector (3pin connector plug)

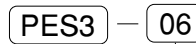

Wire length

06	600 mm(standard)
10	1,000 mm

PHS 500 Series

Construction

Single Solenoid Valve

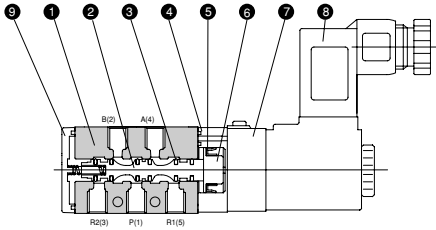

Double Solenoid Valve

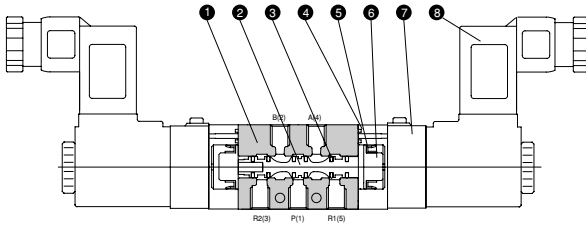

3 Position Solenoid Valve

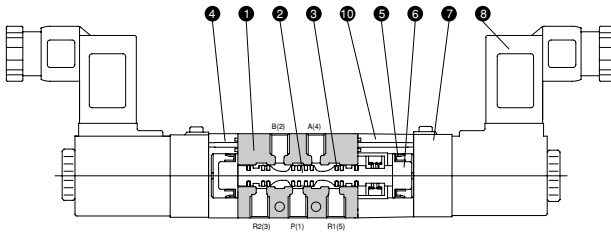

NO.	Description	Material
1	Body	Aluminum Diecasting
2	Spool	Aluminum Diecasting
3	Spool Packing	NBR
4	Cap	Zinc
5	Piston	Resin
6	Semi Pilot	Zinc
7	Pilot	Resin
8	Coil Ass'y	Resin
9	End Cover	Zinc
10	Block Pilot	Zinc

Dimension

(Unit: mm)

PHS500S

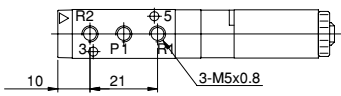
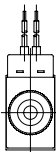
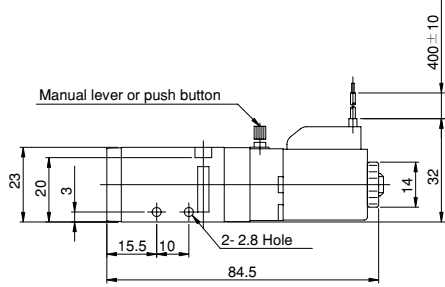
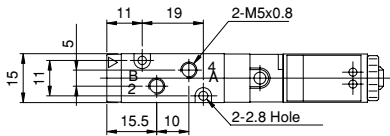

Perpendicular Connector

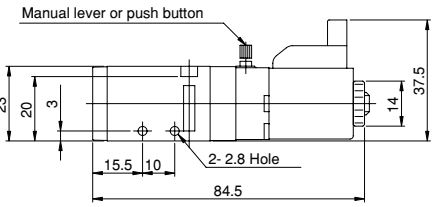

horizontal Connector

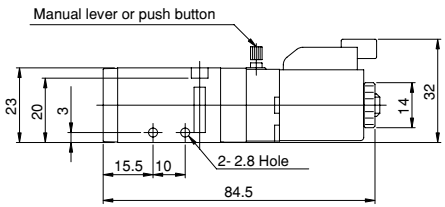

PHS500 Series

Dimension

(Unit: mm)

PHS500D

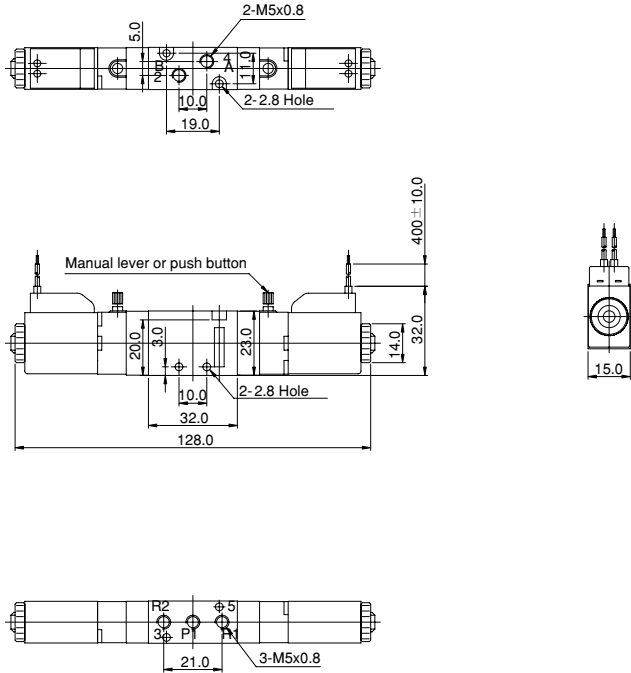

Perpendicular Connector

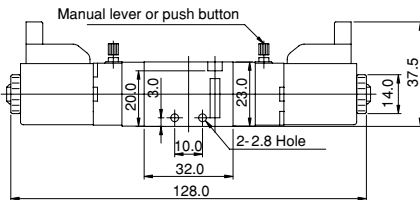

Horizontal Connector

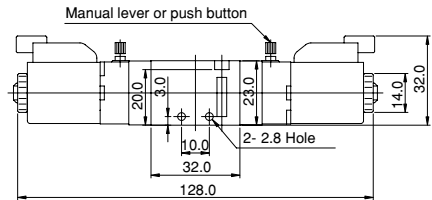

Dimension

(단위 : mm)

PHS500C, PHS500E, PHS500P

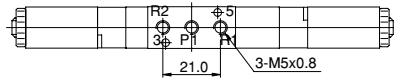
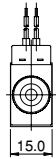
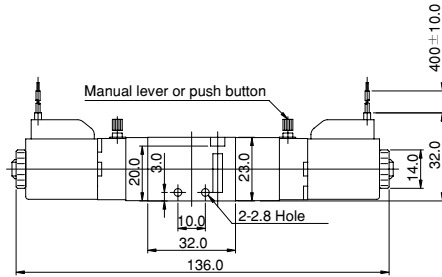
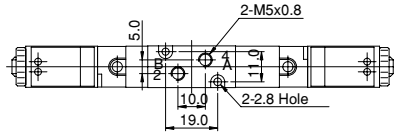

Perpendicular Connector

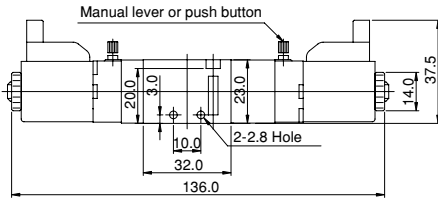

Horizontal Connector

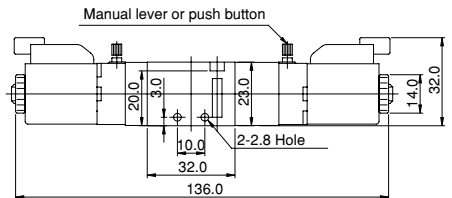

Manifold

ORDER KEY

PHS500 — **M5**

Mountable Valve
PHS510 Series

Number of Station

M2	2 station
:	:
M9	9 station

Specification

Type		PHS500-M□
		Common Sup, Common EXH Port 2, 4 on the body
Port Size	Port 1	Rc 1/8
	Port 3, 5	Rc 1/8
	Port 2, 4	Rc 1/8
Station		2 ~ 9 Station
Mounting		Direct mount
Monutable Valve		PHS 500
Blanking Plate		PHS500-BP

Dimensions

(Unit: mm)

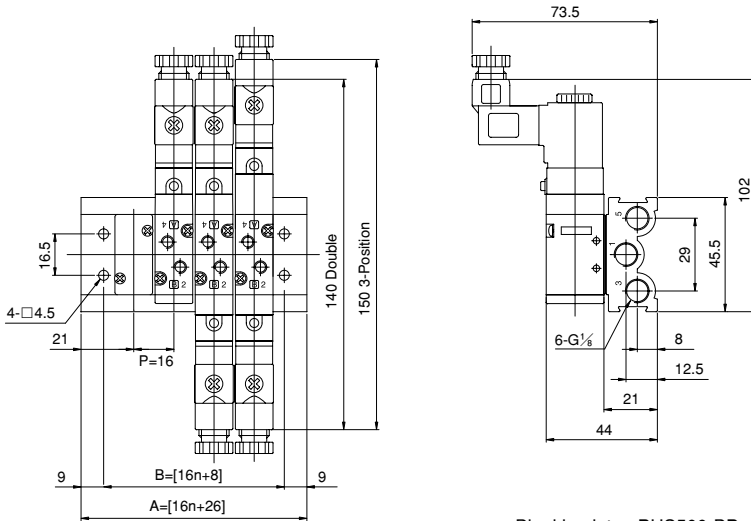

Blanking plate : PHS500-BP

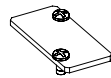
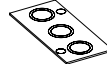

Plate material : SCP1



Gasket material : NBR

5 Port Pilot Operated Solenoid Valve

PHS510 Series

Rubber Seal/In-Line Type

PHS510S 2 Position
Single solenoid

PHS510D 2 Position
Double Solenoid

PHS510C 3 Position
Center Closed

PHS510E 3 Position
Exhaust Center

PHS510P 3 Position
Pressure Center



Specifications

Model No	Unit	PHS510S	PSH510D	PHS510C	PHS510E	PHS510P
Fluid		Non-lubricated / Lubricated Air				
Port Size		PT 1/8"				
Effective Area	mm ² (Cv)	12.6(0.6)			9.0(0.4)	
Temperature Range	°C	5~60°C				
Pressure Range	MPa(bar)	0.15~0.9(1.5~9.0)	0.1~0.9(1.0~9.0)	0.2~0.9(2.0~9.0)		
Max. Operating Cycle	cycle/s	10			3	
Response Time	ms	20 or less			o	35 r less
Exhaust Type		Individual Exhaust				
Manual Override		Non-lock(Standard), Lever-lock(Option)				
Shock Vibration Resistance	m/s ²	30G~5G(8.3~200Hz)				

Electrical Specifications

Voltage	V	DC24V, AC110V, AC220V(50~60Hz)
Allowable Voltage Fluctuation	%	±10%
Power Consumption	W, VA	DC24V(2.5W), AC110V(4VA), AC220V(4VA)
Insulation class		F
Wiring		Lead Wire, DIN Connector
Indicator Light		LED

PHS510 Series

ORDER KEY

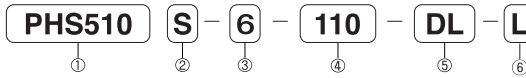

1. Series

5 Port Solenoid Valve

2. Function

S	Single Solenoid
D	Center Closed
C	Center Closed
E	Exhaust Center
P	Pressure Center

3. Port Size

6	PT 1/8"
---	---------

4. Voltage

24V	DC24V
110V	AC110V
220V	AC220V

5. Wiring

NO mark	Lead Wire
D	DIN Connector
DL	DIN Connector w/Lamp

6. Manual Override

NO mark	Non-Lock
L	Lever-Lock

Coil & Connector

Coil

PEC5	DC24	D
Voltage	Wiring	
24V	DC24	No mark Lead Wire
110V	AC 110V	D DIN
220V	AC 220V	

Connector

PES5	L	24V
Lamp Indicator	Voltage	
No mark	No Lamp Indicator	24V DC24
L	w/lamp Indicator	110V AC 110V
		220V AC 220V

Construction

Single Solenoid

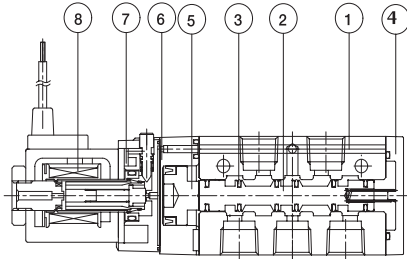

Double Solenoid

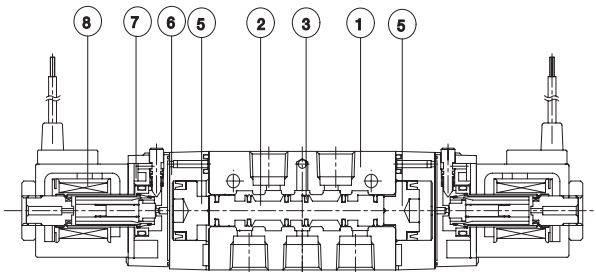

(3-position)

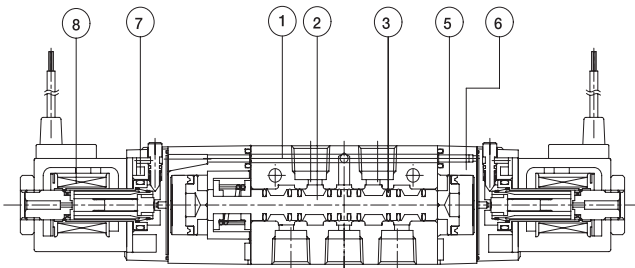

NO	Description	Material
1	Body	Aluminum Diecasting
2	Spool	Aluminum Diecasting
3	Spool Packing	NBR
4	Cap	Zinc
5	Piston	Resin
6	Semi Pilot	Zinc
7	Pilot	Resin
8	Coil Ass'y	Resin

PHS510 Series

Dimensions

PHS510S

(Unit : mm)

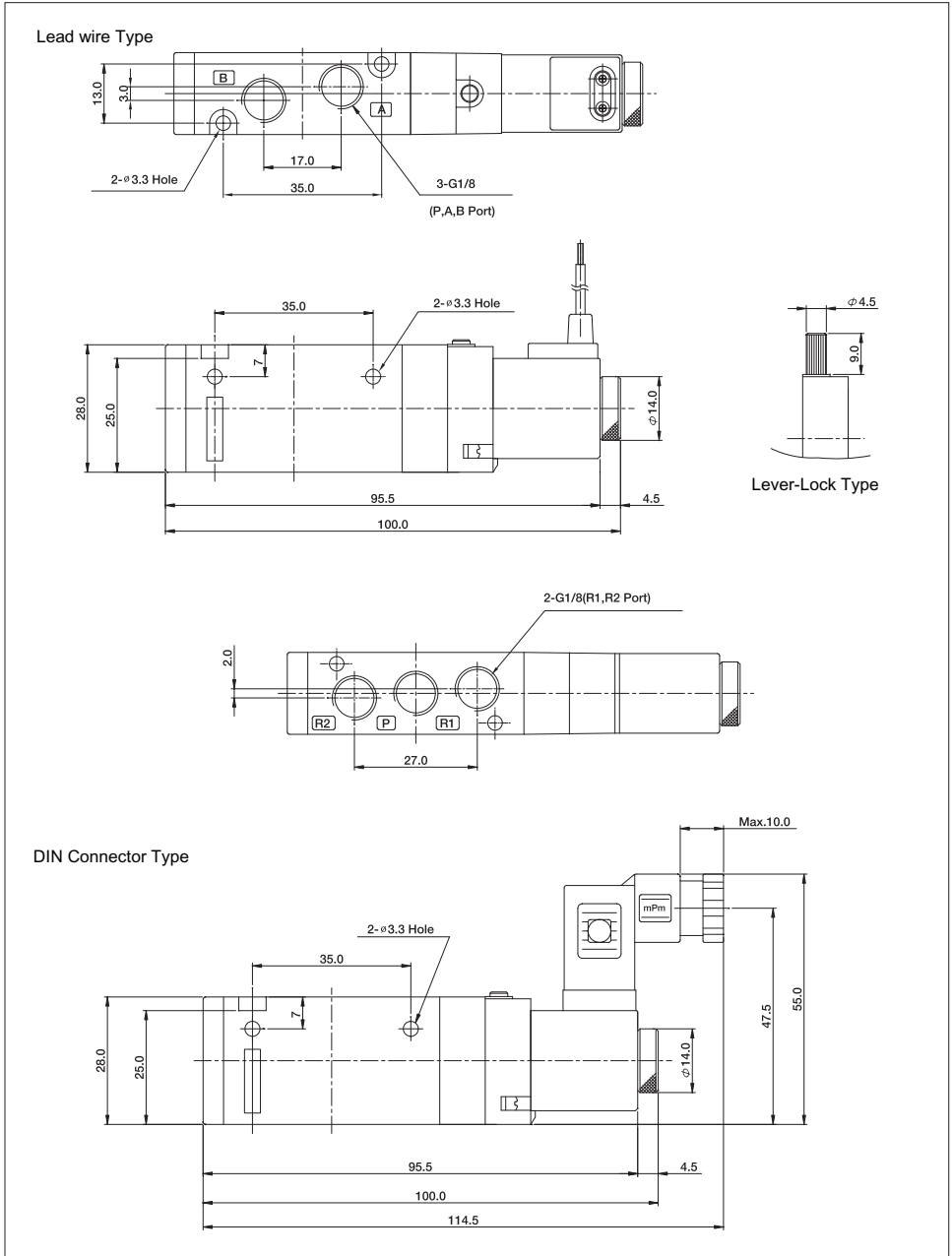

Dimensions

PHS510D

(Unit : mm)

Lead wire Type

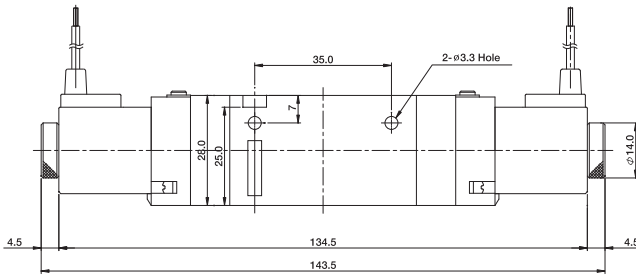
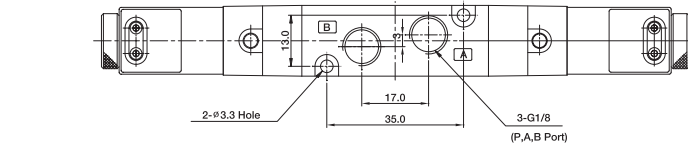

Lever-Lock Type

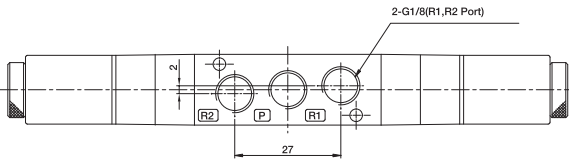

DIN Connector Type

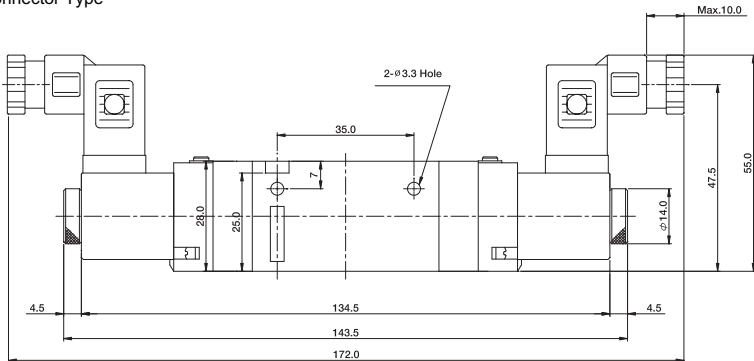

PHS510 Series

Dimensions

PHS510C, PHS510E, PHS510P

(Unit : mm)

Lead wire Type

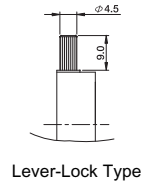
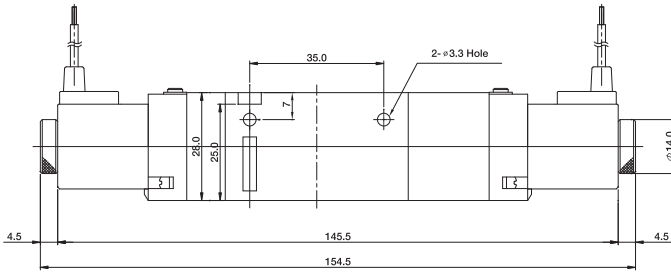
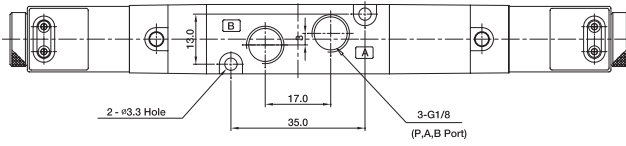

Lever-Lock Type

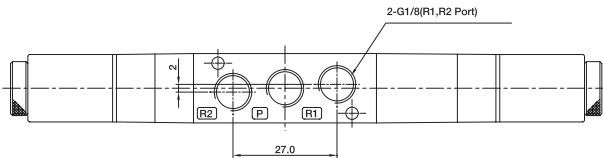

DIN Connector Type

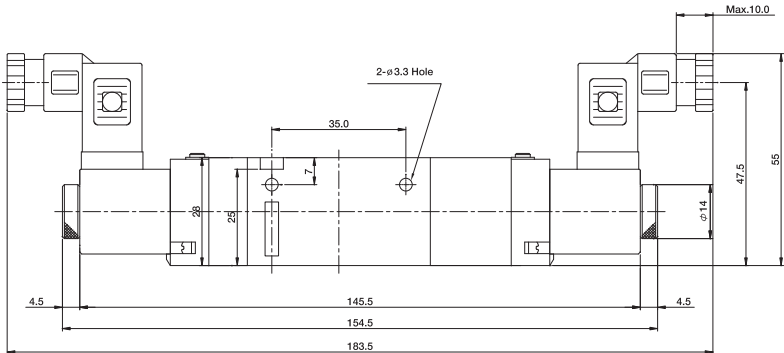

PHS510 Series / Manifold

ORDER KEY

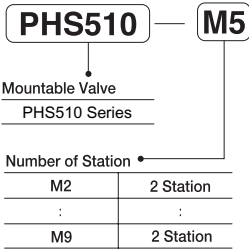

Specification

Type		PHS510-M□	
		Common SUP, Common EXH	
Port Size		Port 2, 4 on the body	
		Port 1	Rc1/4
		Port 3, 5	Rc1/4
Station		Port 2, 4	Rc1/4
		2-9 Station	
Mounting		Direct mount	
Mountable Valve		PHS510 Series	
Blanking Plate		PHS510-BP	

Dimensions

(Unit : mm)

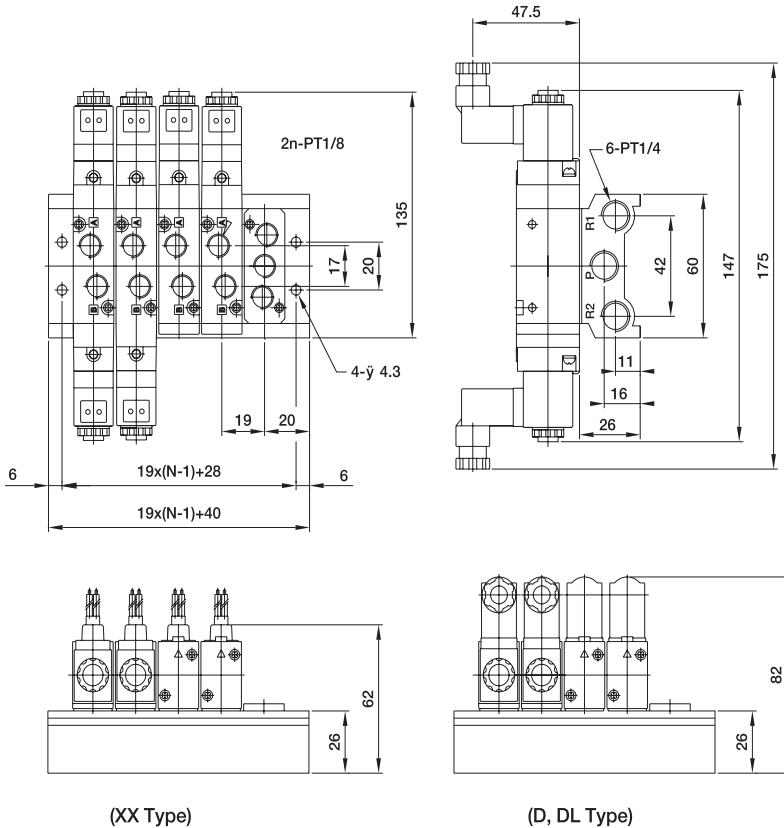

5 Port Pilot Operated Solenoid Valve

PHS520 Series

Rubber Seal/In-Line Type



PHS520S 2 Position
Single solenoid

PHS520D 2 Position
Double Solenoid

PHS520C 3 Position
Center Closed

PHS520E 3 Position
Exhaust Center

PHS520P 3 Position
Pressure Center

Specifications

Model No	Unit	PHS520S	PHS520D	PHS520C	PHS520E	PHS520P
Fluid		Non-lubricated / Lubricated Air				
Port Size		PT 1/4"				
Effective Area	mm ² (Cv)	18(1.0)			14(0.8)	
Temperature Range	°C	5~60 °C				
Pressure Range	MPa(bar)	0.15~0.9(1.5~9.0)	0.1~0.9(1.0~9.0)	0.2~0.9(2.0~9.0)		
Max. Operating Cycle	cycle/s	10			3	
Response Time	ms	20 or less			35 or less	
Exhaust Type		Individual Exhaust				
Manual Override		Non-lock(Standard), Lever-lock(Optional)				
Shock/Vibration Resistance	m/s ²	30G~5G(8.3~200Hz)				

Electrical Specifications

Voltage	V	DC24V, AC110V, AC220V(50~60Hz)
Allowable Voltage Fluctuation	%	±10%
Power Consumption	W, VA	DC24V(2.6W), AC110V(4VA), AC220V(3.5VA)
Insulation class		F
Wiring		Lead Wire, DIN Connector
Indicator Light		LED





ORDER KEY

PHS520
S
8
110
DL
L

①
②
③
④
⑤
⑥

1. Series
5 Port Solenoid Valve

2. Function

S	Single Solenoid 
D	Double solenoid 
C	Center Closed 
E	Exhaust Center 
P	Pressure Center 

3. Port Size

8	PT 1/4"
---	---------

4. Voltage

24V	DC24V
110V	AC110V
220V	AC220V

5. Wiring

No mark	Lead Wire
D	DIN Connector
DL	DIN Connector w/Lamp Indicator

6. Manual Override

No mark	Non-Lock
L	Lever-Lock

Coil & Connector

Connector

Coil

PEC5
DC24
D

Voltage ●

DC24
AC 110V
AC 220V

Wiring

No mark	Lead Wire
D	DIN

- **Explosion Proof Coil**
Explosion Proof Coil can be applied to the PHS Series.
Please refer To 483 pages for detail information

Connector

PEC5
L
DC24

Lamp Indicator ●

No mark	No Lamp Indicator
L	w/ Lamp Indicator

Voltage ●

No mark	No Lamp Indicator
24V	DC24
110V	AC 110V
220V	AC 220V

- **Blanking Plate**
Model : PHS520-BP

PHS520 Series

Construction

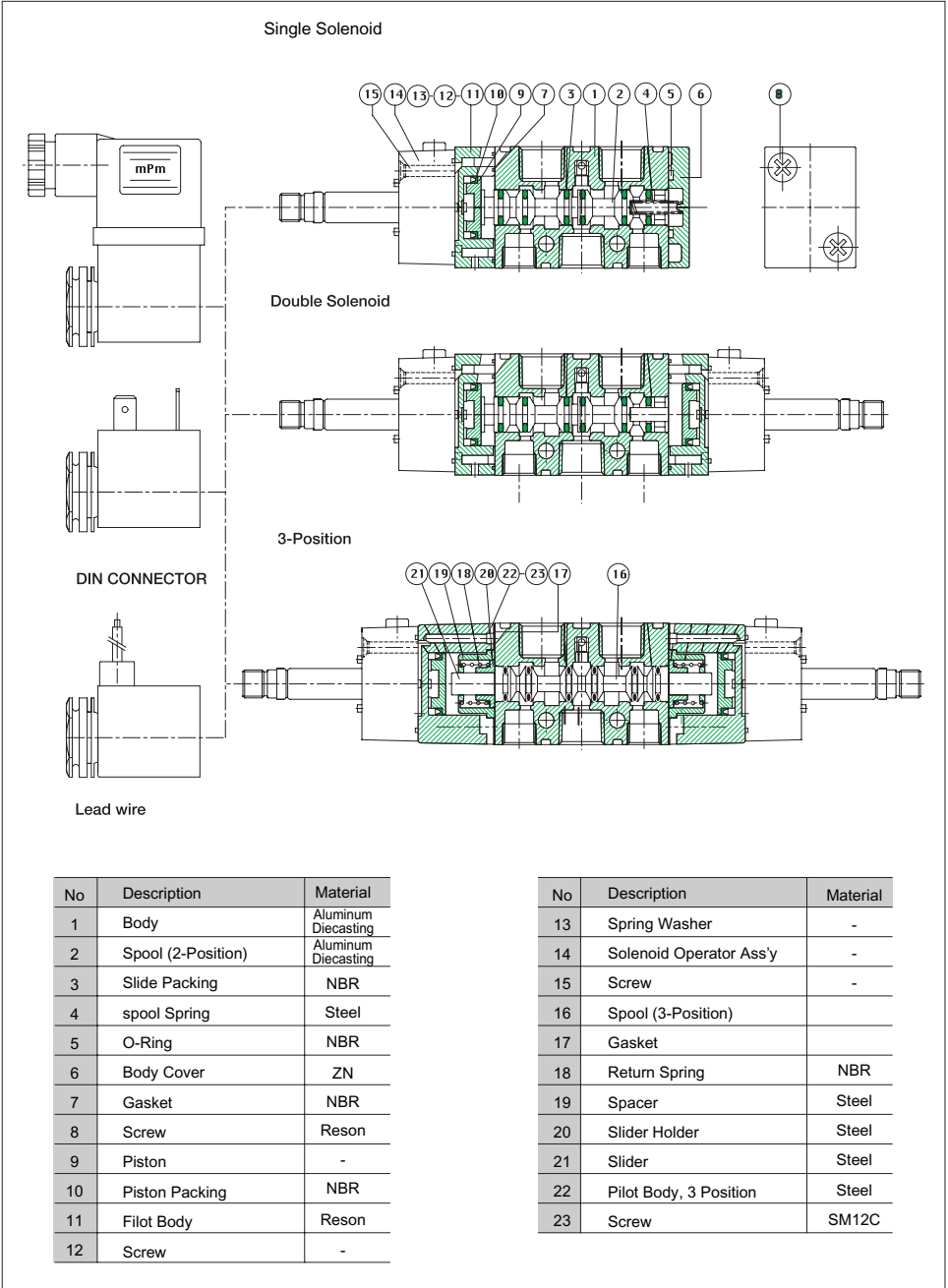

No	Description	Material
1	Body	Aluminum Diecasting
2	Spool (2-Position)	Aluminum Diecasting
3	Slide Packing	NBR
4	spool Spring	Steel
5	O-Ring	NBR
6	Body Cover	ZN
7	Gasket	NBR
8	Screw	Reson
9	Piston	-
10	Piston Packing	NBR
11	Filot Body	Reson
12	Screw	-

No	Description	Material
13	Spring Washer	-
14	Solenoid Operator Ass'y	-
15	Screw	-
16	Spool (3-Position)	
17	Gasket	
18	Return Spring	NBR
19	Spacer	Steel
20	Slider Holder	Steel
21	Slider	Steel
22	Pilot Body, 3 Position	Steel
23	Screw	SM12C

Dimensions

PHS520S

(Unit : mm)

Lead wire Type

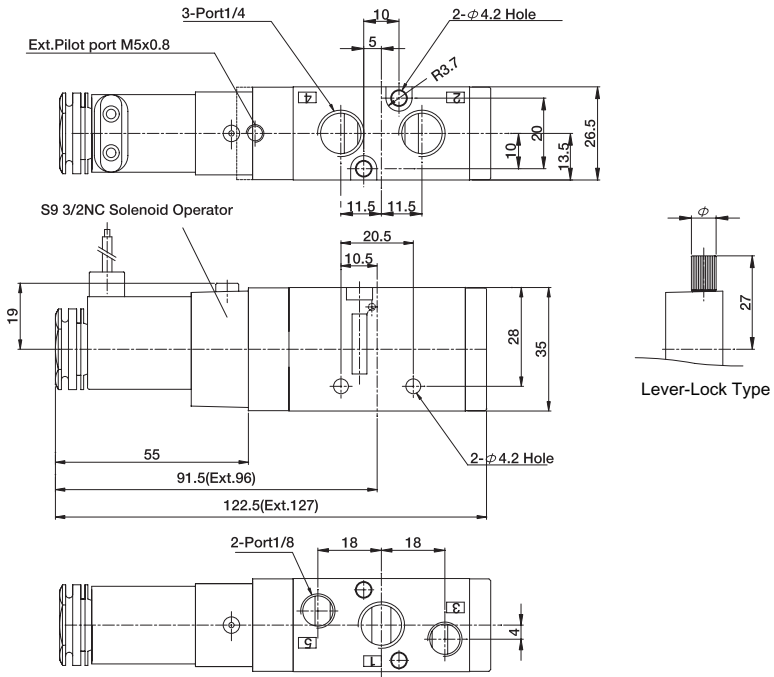

DIN Connector Type

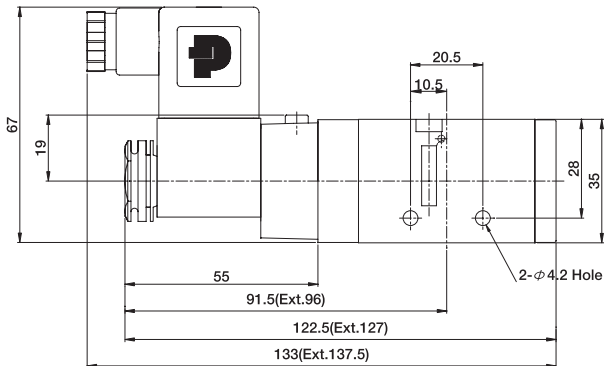

PHS520 Series

Dimensions

PHS520D

(Unit : mm)

Lead wire Type

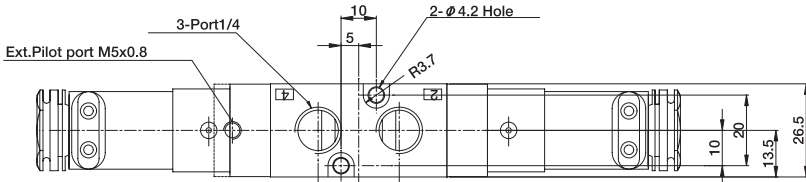

S9 3/2NC Solenoid Operator

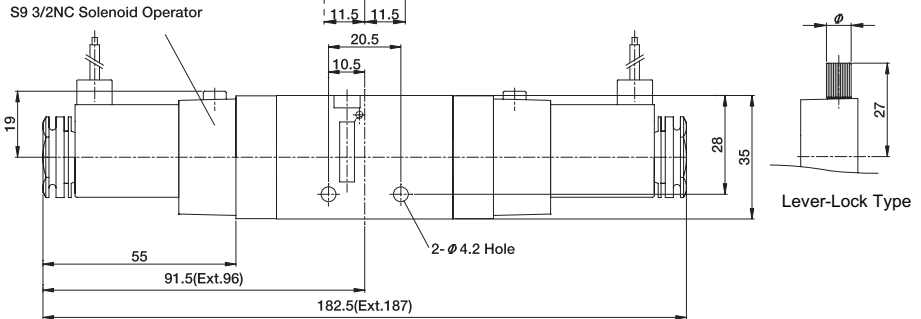

DIN Connector Type

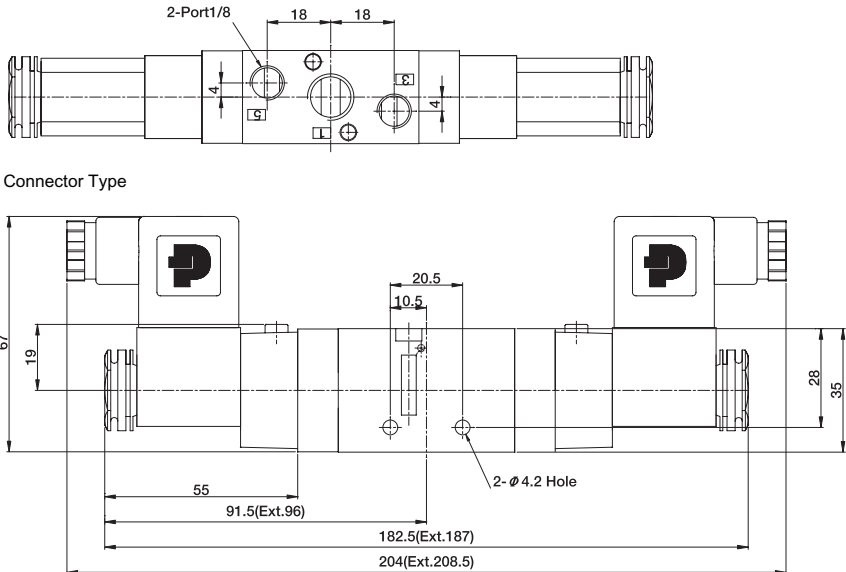

Dimensions

PHS520C, PHS520E, PHS520P

(Unit : mm)

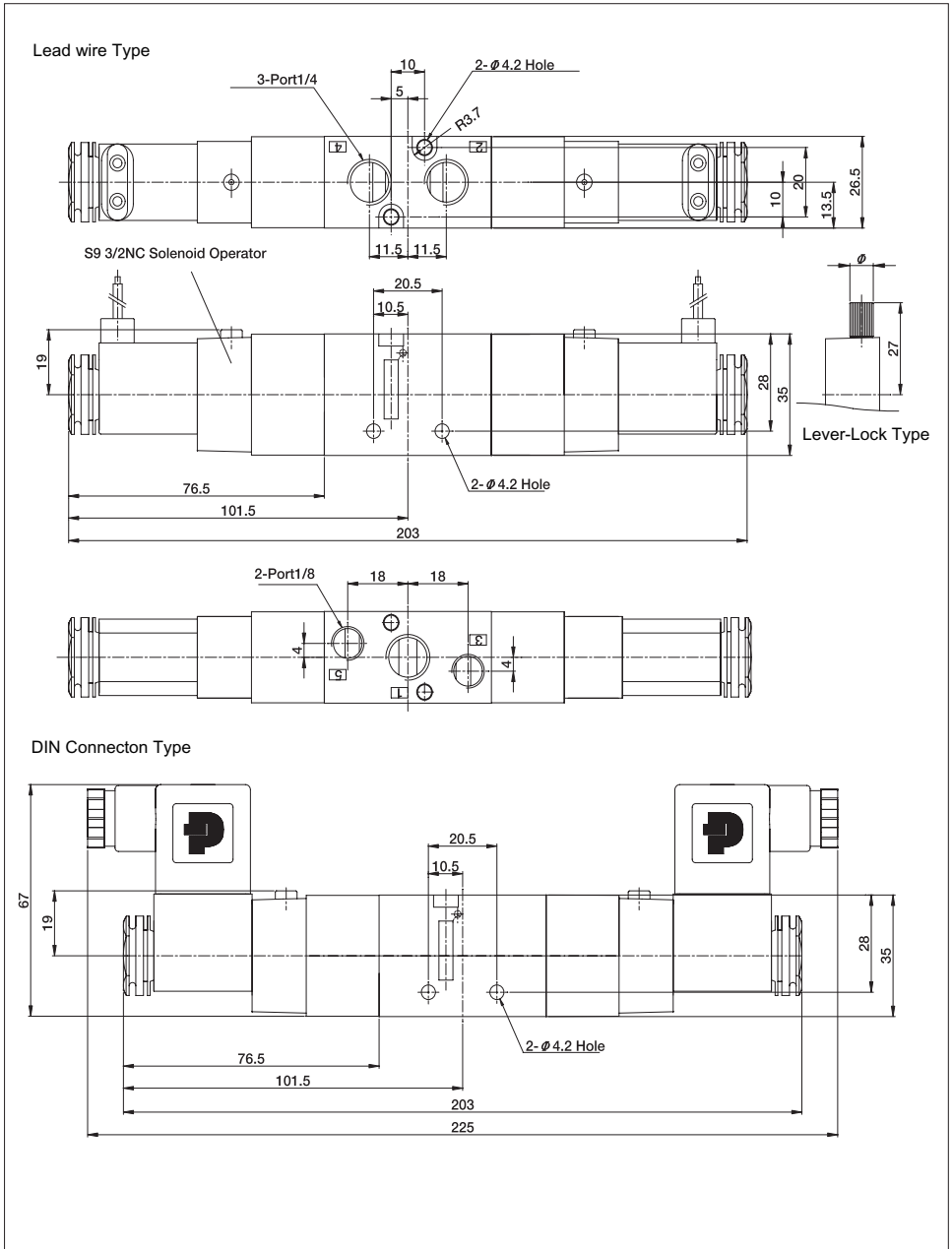

PHS520 Series / Manifold

ORDER KEY

PHS520 — **M5**

Mountable Valve
PHS510 Series

Number of Station

M2	2 Station
:	:
M9	9 Station

Specification

Type	PHS520-M□	
	Common SUP, Common E	
	Port 2, 4 on the body	
Port Size	Port 1	RC 1/4
	Port 3, 5	RC 1/4
	Port 2, 4	RC 1/4
Station	2~9 Station	
Mounting	Direct mount	
Mountable Valve	PHS520 Series	
Blanking Plate	PHS520-BP-	

Dimensions

(Unit : mm)

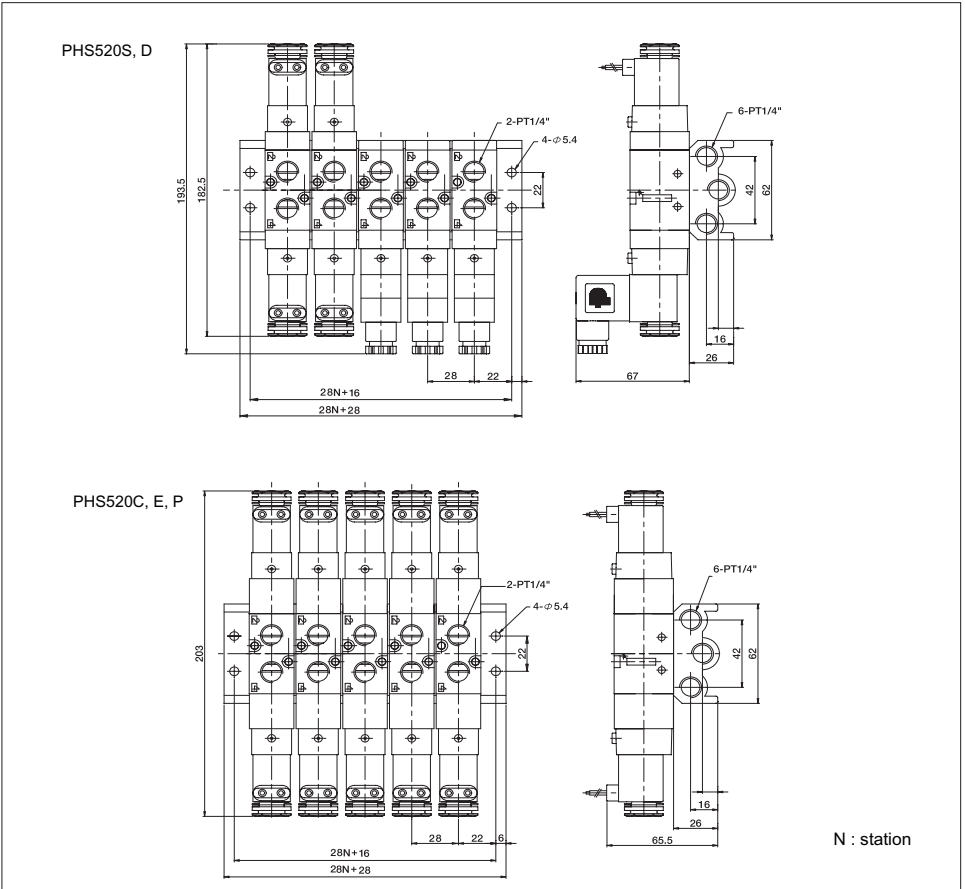

5 Port Pilot Operated Solenoid Valve

PHS530 Series

Rubber Seal / In-Line Type

PHS530S 2 Position
Single solenoid

PHS530D 2 Position
Double Solenoid

PHS530C 3 Position
Center Closed

PHS530E 3 Position
Exhaust Center

PHS530P 3 Position
Pressure Center



Specifications

Model No	Unit	PHS520S	PHS520D	PHS520C	PHS520E	PHS520P
Fluid		Non-lubricated / Lubricated Air				
Port Size		PT 3/8"				
Effective Area	mm ² (Cv)	30(1.6)				
Temperature Range	°C	5~60°C				
Pressure Range	MPa(bar)	0.15~0.9(1.5~9.0)	0.1~0.9(1.0~9.0)	0.2~0.9(2.0~9.0)		
Max. Operating Cycle	cycle/s	8		3		
Response Time	ms	25 or less		35 or less		
Exhaust Type		Individual Exhaust				
Manual Override		Non-lock(Standard), Lever-lock(Optional)				
Shock/Vibration Resistance	m/s ²					

Electrical Specifications

Voltage	V	DC24V, AC110V, AC220V(50~60Hz)
Allowable Voltage Fluctuation	%	±10%
Power Consumption	W, VA	DC24V(2.6V), AC110V(4VA), AC220V(3.5VA)
Insulation class		F
Wiring		Lead Wire, DIN Connector
Indicator Light		LED

PHS530 Series

ORDER KEY

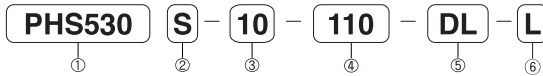

1. Series
5 Port Solenoid Valve

2. Function

S	Single Solenoid
D	Double solenoid
C	Center Closed
E	Exhaust Center
P	Pressure Center

3. Port Size

8	PT 1/4"
---	---------

4. Voltage

24V	DC24V
110V	AC110V
220V	AC220V

5. Wiring

No mark	Lead Wire
D	DIN Connector
DL	DIN Connector w/Lamp Indicator

6. Manual Override

No mark	Non-Lock
L	Lever-Lock

Coil & Connector

Coil

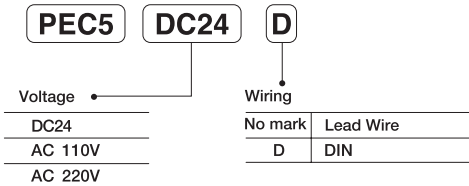

Connector

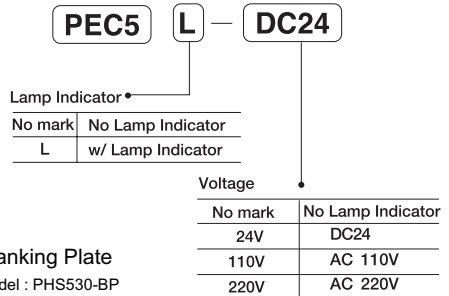

- **Explosion Proof Coil**
Explosion Proof Coil can be applied to the PHS Series.
Please refer To483 pages for detail information

- **Blanking Plate**
Model : PHS530-BP

Construction

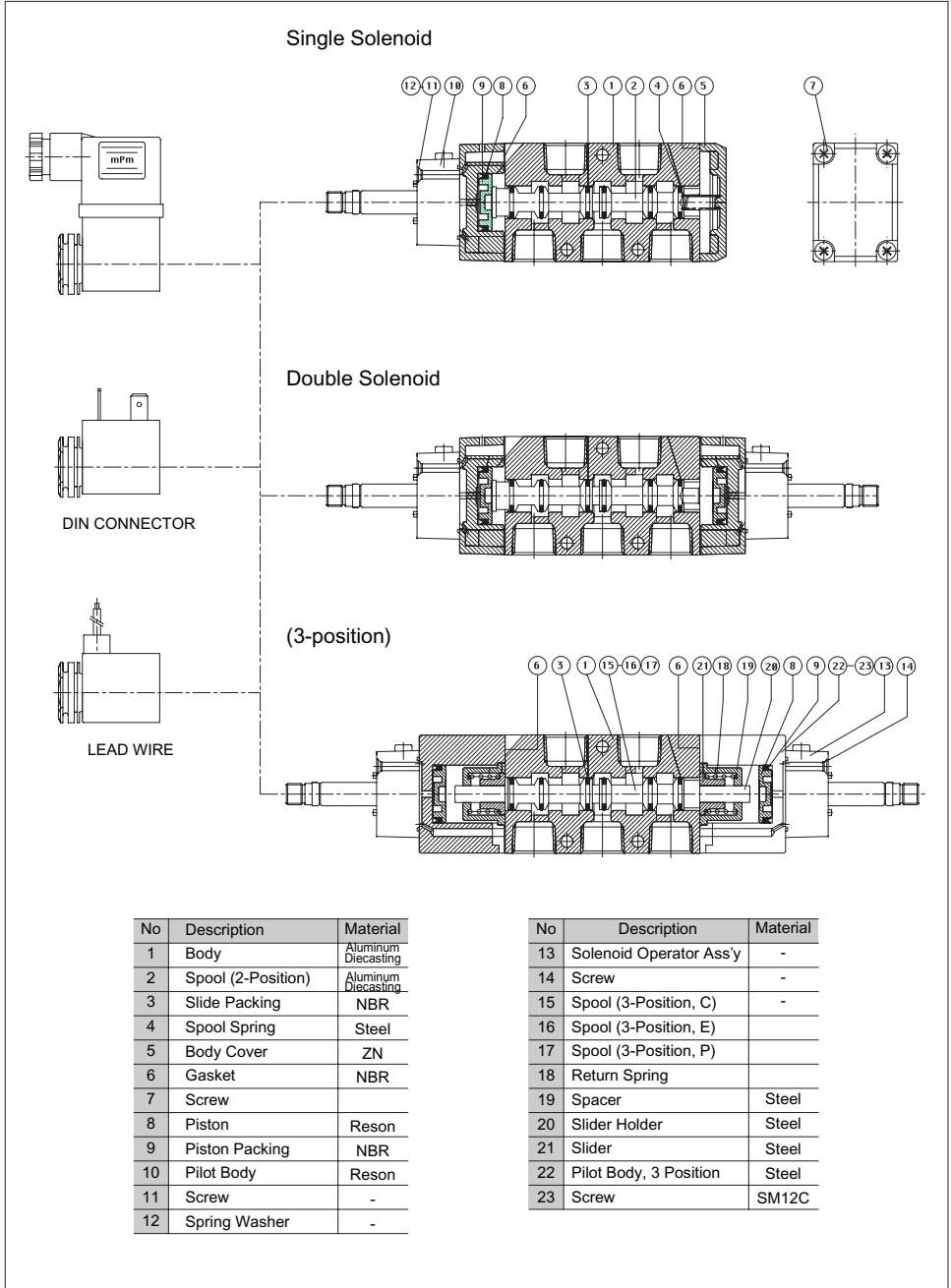

PHS530 Series

Dimension

(Unit: mm)

PHS530S

Lead Wire Type

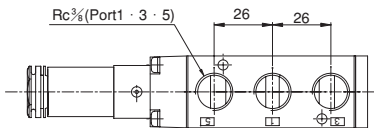
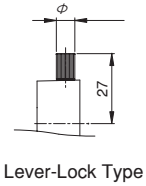
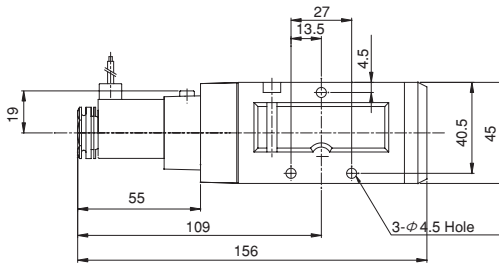
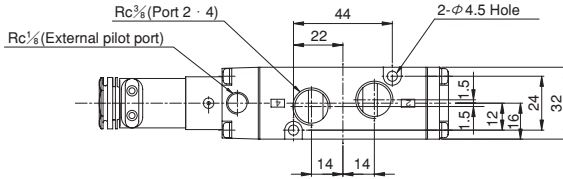

DIN-Connector Type

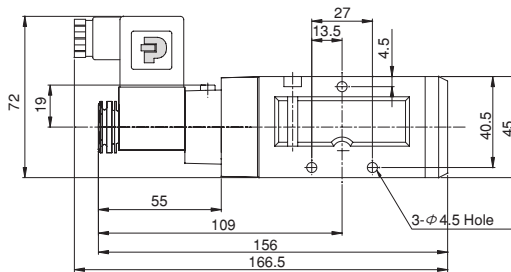

Dimension

(Unit : mm)

PHS530D

Lead Wire Type

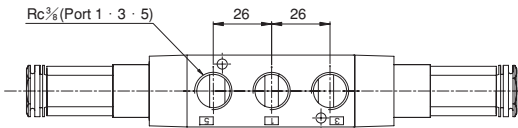
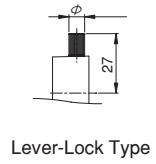
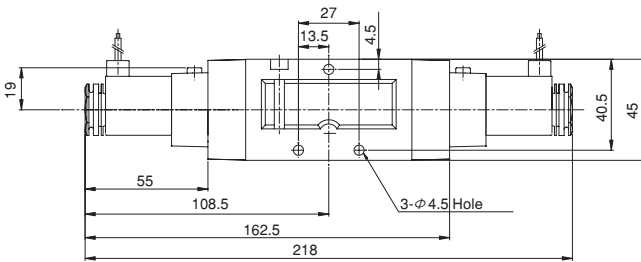
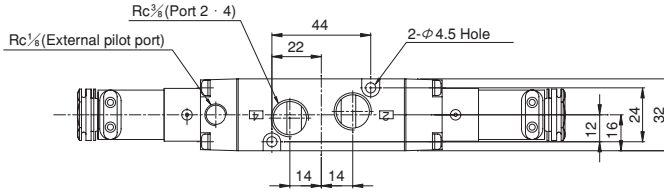

DIN-Connector Type

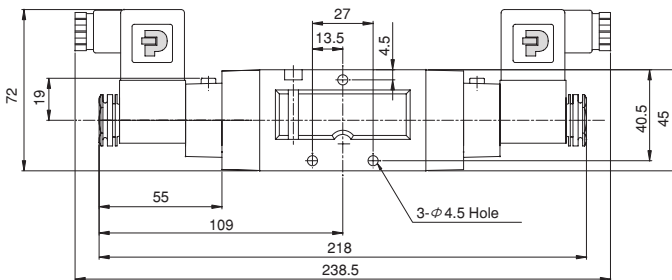

PHS530 Series

Dimension

(Unit : mm)

PHS530C, PHS530E, PHS530P

Lead Wire Type

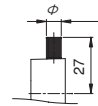
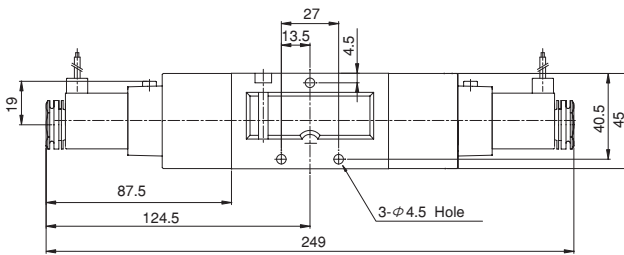
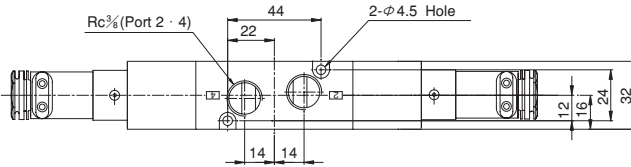

Lever-Lock Type

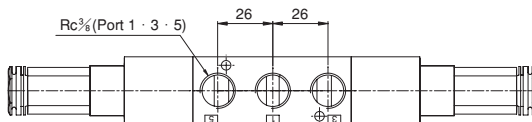

DIN-Connector Type

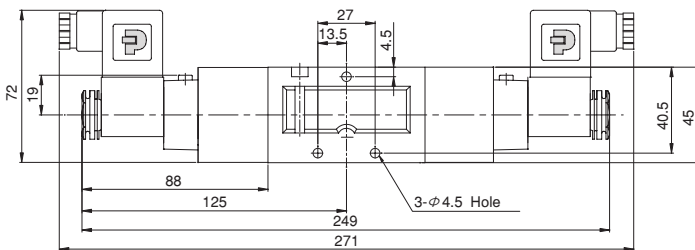

PHS530 Series / Manifold

ORDER KEY

PHS530 — **M5**

Mountable Valve
PHS530 Series

Number of Station

M2	2 Station
:	:
M9	9 Station

Specification

Type	PHS520-M □	
	Common SUP, Common E	
	Port 2, 4 on the body	
Port Size	Port 1	RC 3/8
	Port 3, 5	RC 3/8
	Port 2, 4	RC 3/8
Station	2-9 Station	
Mounting	Direct mount	
Mountable Valve	PHS530 Series	
Blanking Plate	PHS530-BP	

Dimensions

(Unit : mm)

(PHS530S, D)

(PHS530C, E, P)

5 Port Pilot Operated Solenoid Valve

PHS541 Series

Rubber Seal / In-Line Type

PHS541S 2 position
Single Solenoid

PHS541D 2 position
Double Solenoid



Specifications

Model No	Unit	PHS541S		PHS541SD	
Fluid		Non-lubricated / Lubricated Air			
Port Size		PT 3/8"	PT 1/2"	PT 3/8"	PT 1/2"
Effective Area	mm ² (CV)	53(2.9)	56(3.0)	53(2.9)	56(3.0)
Temperature Range	°C	5~60			
Pressure Range	MPA(bar)	0.15~0.9(1.5~9.0)			
Response Time	ms	50 or less			
Exhaust Type		Individual Exhaust			
Manual Override		Non-lock(Standard), Lever-lock(Option)			

Electrical Specifications

Voltage	Unit	DC24D, AC110V, AC220V(50~60Hz)
Allowable Voltage Fluctuation	%	±10%
Power Consumption	W, VA	DC24D(2.6W), AC110V(4VA), AC220V(3.5A)
Insulation class		F
Wiring		Lead Wire, DIN Connector
Indicator Light		LED

ORDER KEY

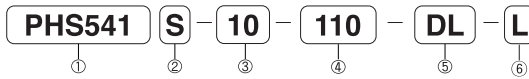

1. Series

2. Function

S	Single Solenoid
D	Double Solenoid

3. Port Size

10	Rc 3/8"
15	RC 1/2"

4. Voltage

24V	DC240V
110V	AC110V
220V	AC220V

5. Wiring

NO mark	Lead Wire
D	DIN Connector
DL	DIN Connector w/ Lamp Indicator

6. Manual Override

NO mark	Non-Lock
	Lever-Lock

PHS541 Series

Construction

(Unit : mm)

Single Solenoid

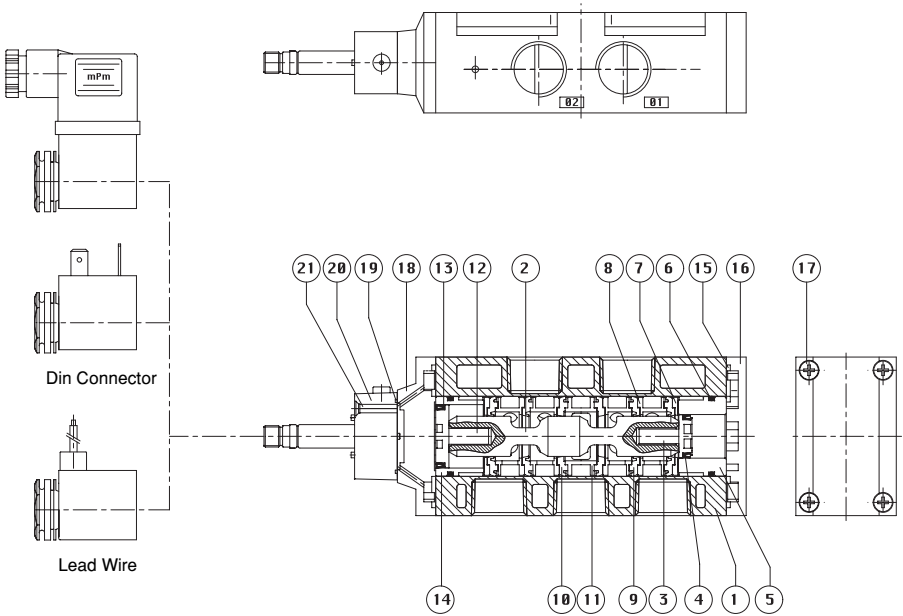

No	Description	Material
1	Body	Aluminum Diecasting
2	Spool	Aluminum Diecasting
3	Return Piston	Resin
4	Cap Packing	NBR
5	Return Tube	Aluminum Diecasting
6	O-Ring	NBR
7	Sleeve Liner	Reson
8	Sleeve-B	Aluminum Diecasting
9	Side Sleeve Packing	Rrethane
10	In Sleeve Packing	Rrethane
11	Sleeve-A	Reson

No	Description	Material
13	Motion Piston	Resin
14	Spool Packing	NBR
15	Motion Tuve	Aluminum Diecasting
16	Pilot Gasket	NBR
17	Body Cover	Aluminum Diecasting
18	Screw	
19	Pilot Body	
20	Pilot Gasket	NBR
21	S9 2/3 NC, Solenoid Operator Ass'y	
22	Lcraw	
23	Coil Nut	Nylon

Dinemsins

PHS541S

(Unit : mm)

Lead wire Type

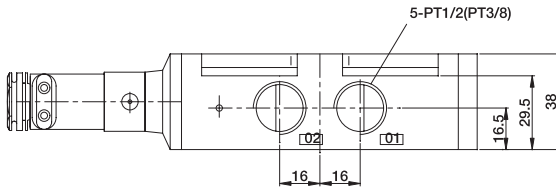

S9 3/2NC Solenoid Operator

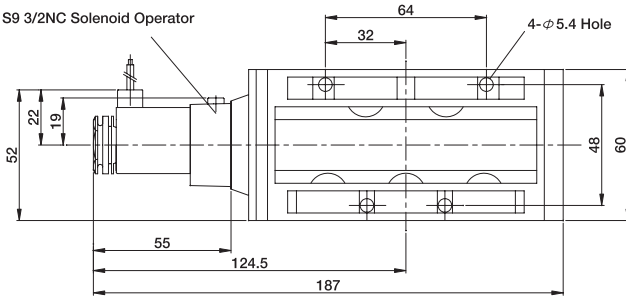

Lever-Lock Type

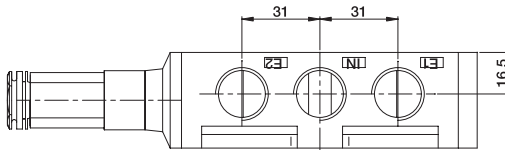

DIN Connector Type

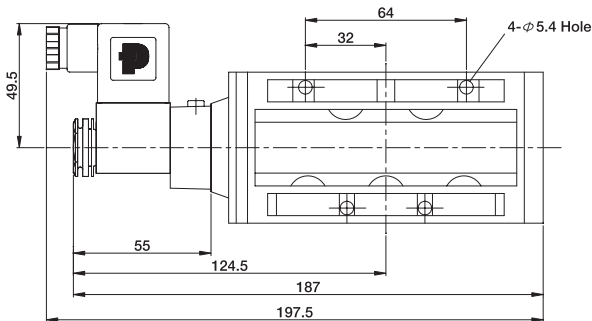

PHS541 Series

Dinemsins

PHS541D

(Unit : mm)

Lead wire Type

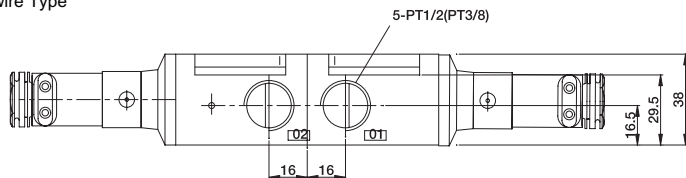

S9 3/2NC Solenoid Operator

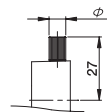
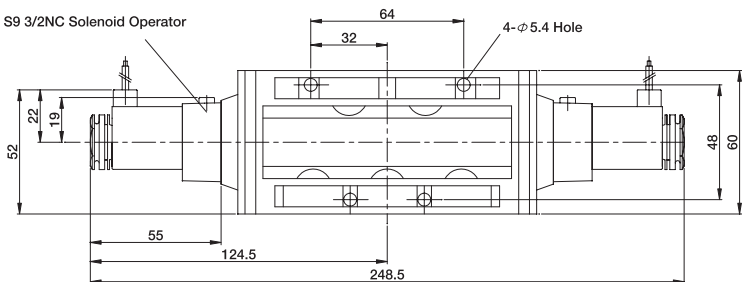

Lever-Lock Type

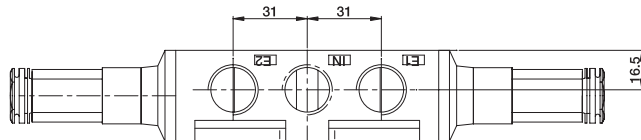

DIN Connector Type

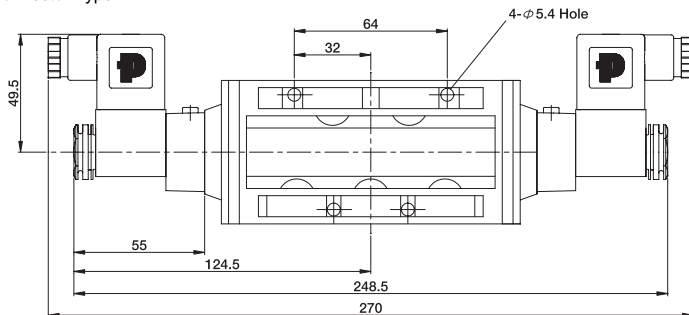

5 Port Pilot Operated Solenoid Valve

PHS540 Series

Rubber Seal / In-Line Type



PHS540S 2 Position
Single solenoid

PHS540D 2 Position
Double Solenoid

Specifications

Model No	Unit	PHS540S		PHS540D	
Fluid		Non-lubricated / Lubricated Air			
Port Size		PT 3/8"	PT 1/2"	PT 3/8"	PT 1/2"
Effective Area	mm ² (CV)	53(2.9)	56(3.0)	53(2.9)	56(3.0)
Temperature Range	°C	5~60			
Pressure Range	MPA(bar)	0.15~0.9(1.5~9.0)			
Response Time	ms	50 or less			
Exhaust Type		Individual Exhaust			
Manual Override		Non-lock(Standard), Lever-lock(Option)			

Electrical Specifications

Voltage	Unit	DC24D, AC110V, AC220V(50~60Hz)
Allowable Voltage Fluctuation	%	±10%
Power Consumption	W, VA	DC24D(2.6W), AC110V(4VA), AC220V(3.5A)
Insulation class		F
Wiring		Lead Wire, Connector
Indicator Light		LED

PHS540 Series

ORDER KEY

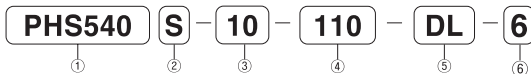

1. Series

2. Function

S	Single Solenoid
D	Double Solenoid

3. Port Size

10	Rc 3/8"
15	RC 1/2"

4. Voltage

24V	DC240V
110V	AC110V
220V	AC220V

5. Wiring

NO mark	Lead Wire
D	DIN Connector
DL	DIN Connector w/ Lamp Indicator

6. Manual Override

NO mark	Non-Lock
L	Lever-Lock

Construction

Single Solenoid

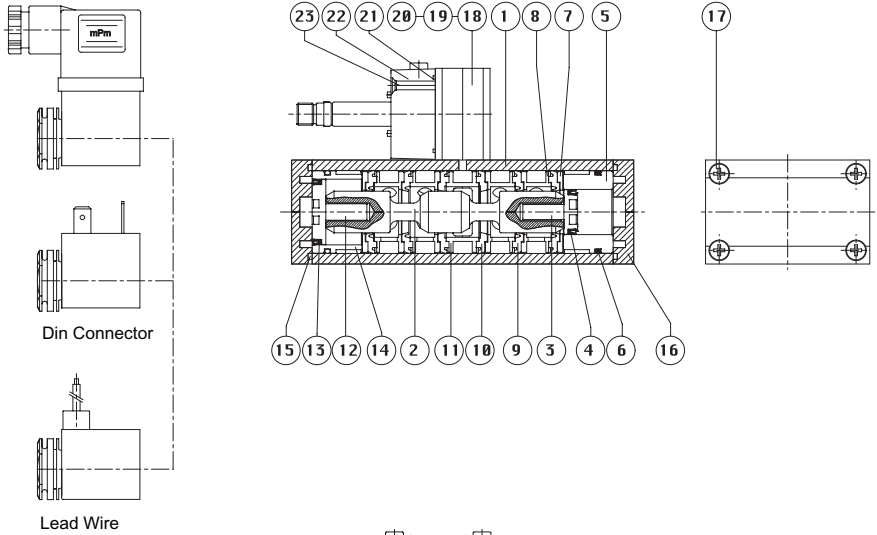

Double Solenoid

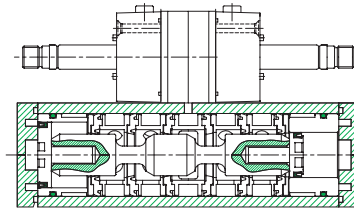

No	Description	Material
1	Body	Aluminum Diecasting
2	Spool	Aluminum Diecasting
3	Return Piston	Plastic
4	Cap Packing	NBR
5	Return Tube	Aluminum Diecasting
6	O-Ring	NBR
7	Sleeve Liner	Plastic
8	Sleeve-B	Aluminum Diecasting
9	Side Sleeve Packing	Urethane
10	In Sleeve Packing	Urethane
11	Sleeve-A	Plastic
12	Motion Piston	Plastic

No	Description	Material
13	Spool Packing	NBR
14	Motion Piston	
15	Spool Packing	NBR
16	Motion Tuve	Aluminum Diecasting
17	Pilot Gasket	
18	Body Cover	
19	Screw	
20	Pilot Body	NBR
21	Pilot Gasket	NBR
22	S9 2/3 NC, Solenoid Operator Ass'y	
23	Lcrew	
24	Coil Nut	NYLON

PHS540 Series

Dimensions

PHS540S

(Unit : mm)

Lead wire Type

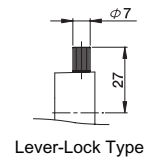
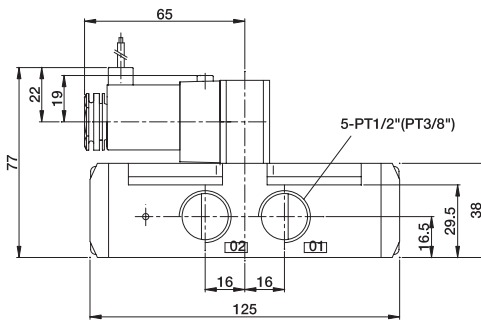
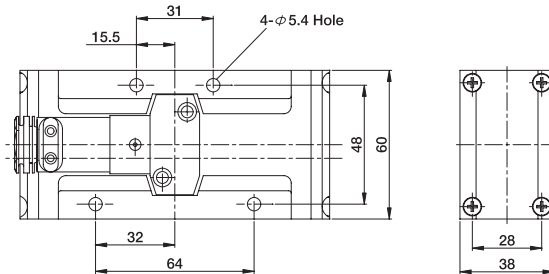

DIN Connector Type

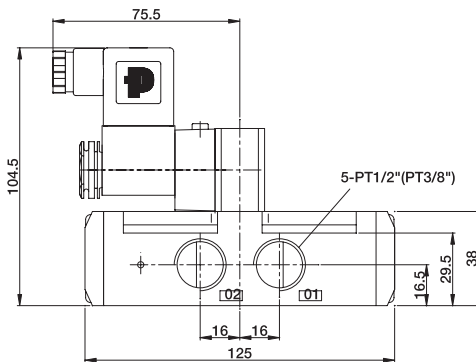

Dimensions

PHS540D

(Unit : mm)

Lead wire Type

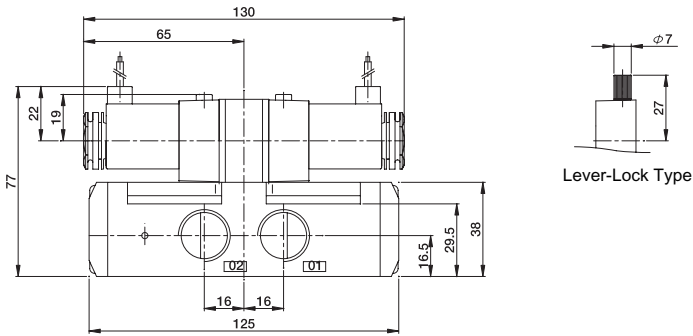
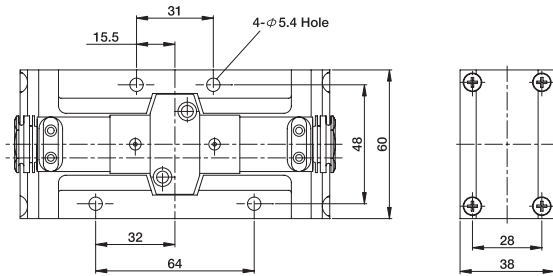

DIN Connector Type

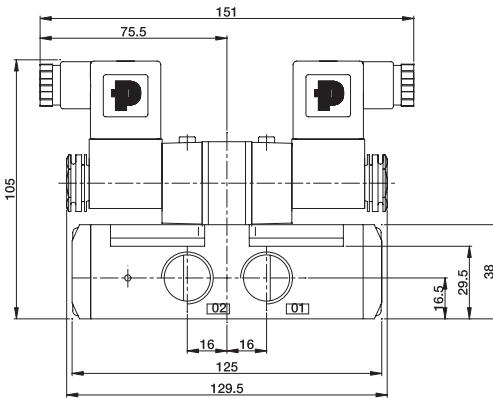

Explosion Proof Coil for PHS Series

ORDER KEY

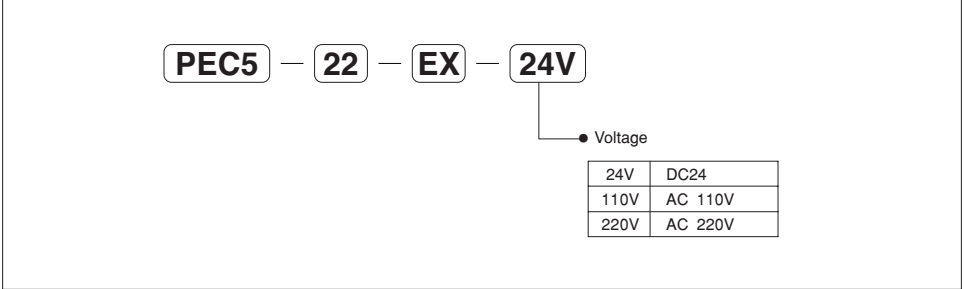

Explosion Proof Grade

