



Level Switch

NRS 1-50

For **ONE** electrode

EN (USA)
English

Original Installation &
Operating Manual
850693-00

Contents

Content of this Manual	4
Scope of supply, product package	4
How to use this Manual	5
Illustrations and symbols used	5
Hazard symbols in this Manual	5
Types of warning	6
Specialist terms, abbreviations	7
Usage for the intended purpose	8
Applicable directives and standards.....	8
Improper use	8
Basic safety information	9
Required personnel qualifications	10
Notes on product liability	10
Function	11
Technical data	12
Rating plate, identification	13
Factory default settings	14
Dimensions of the NRS 1-50	15
Important notes	16
Safety information	16
Preparing for installation	17
Installation	18
Electrical connection	19
Supply voltage	19
Connecting the level electrode	19
Connecting the safety circuit.....	19
Connecting the signal output	20
Wiring diagram of level switch NRS 1-50.....	21
Connection example for Class C.....	22
Example switching combinations	23



Bringing into service	25
Checking the switchpoint and function.....	25
Operation, alarm and test	26
Fault indications and troubleshooting	27
Checking the level electrode	28
Measuring level switch voltages	28
Important notes	29
Action against high-frequency interference	29
Interlock and interlock deactivation.....	29
Checking switchpoints.....	29
Taking out of service	30
Disposal	30
UL components	30

Content of this Manual

Product:

- Level Switch NRS 1-50, for ONE electrode

First edition:

BAN 850693-00/09-2021cm

© Copyright

All rights reserved. Any misuse, particularly reproduction and dissemination to third parties, is not permitted. The General Terms & Conditions of GESTRA AG apply.

Scope of supply, product package

NRS 1-50

1 level switch NRS 1-50

1 Installation & Operating Manual

How to use this Manual

This Installation & Operating Manual describes the correct use of the NRS 1-50 level switch. It applies to persons who integrate this equipment in control systems, install, bring into service, operate, maintain and dispose of this equipment. Anyone carrying out the above-mentioned activities must have read this Installation & Operating Manual and understood its contents.

- Read this Manual in full and follow all instructions.
- Please also read the instructions for use of any accessories.
- The Installation & Operating Manual is part of the product package. Keep it in an easily accessible location.

Availability of this Installation & Operating Manual

- Make sure this Installation & Operating Manual is always available to the operator.
- If you pass on or sell the equipment to a third party, please also hand over the Installation & Operating Manual.

Illustrations and symbols used

1. Action to be taken
- 2.

-
- Lists
 - ◆ Bullet points in lists

A Keys to illustrations



Additional information



Read the relevant Installation & Operating Manual

Hazard symbols in this Manual



Danger zone, dangerous situation

Types of warning

DANGER

Warning of a dangerous situation that results in death or serious injury.

WARNING

Warning of a dangerous situation that may possibly result in death or serious injury.

CAUTION

Warning of a situation that may result in minor or moderate injury.

ATTENTION

Warning of a situation that results in damage to property or the environment.

Specialist terms, abbreviations

Here, we explain some abbreviations, specialist terms, etc., which are used in this Manual.

NRGT .. / NRR.. / NRS.. / URS .. / URB .. / SRL .. / etc.

Equipment and type designations of GESTRA AG.

SELV

Safety Extra Low Voltage

Operating point (of the plant)

The operating point describes the operating parameters within which a plant or boiler is operated in its nominal range. In a steam boiler, for example, these parameters would be output, pressure, and temperature.

The design data may be a lot more stringent, however.

A boiler that is operated at 145 psi (10 bar) and 356°F (180°C) may be designed to withstand a pressure of 870 psi (60 bar) and a temperature of 527°F (275°C), for example, which is therefore not necessarily its operating point.

Usage for the intended purpose

The NRS 1-50 level switch is used in conjunction with the NRG 1...-50 level electrode as a water level limiter for steam boilers and hot water installations.

Water level limiters switch off the heating when the water drops below the set low water level (LW). The NRS 1-50 is classified as a protective control Class B (C) in accordance with UL60730-1.

When used as intended, the NRS 1-50 level switch is combined in a circuit with the level electrodes stipulated by the directives or standards below:

Level electrodes NRG 1...-..			
UL60730-2-15 CAN/CSA E60730-2-15	NRG 16-50	NRG 17-50	NRG 19-50

Applicable directives and standards

The equipment has been tested and approved for use in the scope governed by the following directives and standards:

Standards:

- UL 60730-1 and CAN/CSA E60730-1
General Requirements for Automatic Electrical Controls
- UL 60730-2-15 and CAN/CSA E60730-2-15
Requirements for Automatic Electrical Water Level Sensing Controls

Improper use



There is a danger of death due to explosion if the equipment is used in potentially explosive atmospheres.

Do not use the equipment in potentially explosive atmospheres.



Do not bring any equipment into service that does not have its own specific rating plate.

The rating plate indicates the technical features of the equipment.

Basic safety information



There is a risk of electric shock during work on electrical systems.

- Always switch off the voltage to the plant before performing connection work.
 - Check that the plant is not carrying live voltage before commencing work.
-



Attempts to repair the equipment will cause the plant to become unsafe.

- The NRS 1-50 level switch may only be repaired by the manufacturer, GESTRA AG.
 - Only replace faulty equipment with identical equipment from GESTRA AG.
-

Required personnel qualifications

Activity	Personnel	
Integration in control system	Specialist staff	Plant designer
Installation/ electrical connection/ bringing into service	Specialist staff	The equipment may only be installed, wired and brought into service by qualified and competent staff.
Operation	Boiler service technician	Staff trained by the plant operator.
Maintenance work	Specialist staff	Fitting and maintenance work may only be performed by authorized staff who have undergone specific training.
Refits	Specialist staff	Persons trained by the plant operator to work with pressure and temperature.

Notes on product liability

The manufacturer cannot accept any liability for damages resulting from improper use of the equipment.

Function

The NRS 1-50 level switch is designed for different boiler water conductivities and for the connection of a single level electrode.

If the water falls below the minimum level, the level electrode is exposed and an alarm is triggered in the level switch. This switchpoint is determined by the length of the electrode extension (level electrode NRG 1...-50).

When the off delay has elapsed, the two output contacts of the level switch open the safety circuit for heating. The heating cut-off is interlocked in the external safety circuit and this interlock can only be deactivated again when the level electrode is immersed once more. In addition, the signal contact for external signaling devices closes without a delay. The NRS 1-50 level switch must be used in combination with an external manual reset when used as a protective device per ASME CSD-1.

An alarm is also triggered if faults occur in a level electrode and/or in the electrical connection.

If the level electrode is installed in a level pot outside the boiler, make sure the connection pipes are sufficiently large.

The manufacturer recommends connection pipes of ≥ 1.57 in (40 mm) for steam and ≥ 3.94 in (100 mm) for water. If smaller connection pipes or fittings are used, these shall not be smaller than 1-inch NPS. The level pot must have a suitable flushing device at its lowest point. This device flushes the connection pipes to the boiler and enables the function of the water level limiter to be tested. No shut-off valves of any type shall be placed in the piping between the boiler and the low water cut-off.

An automatic self-test monitors the safety functions in the level switch and the level electrode. In the event of a fault, the safety circuit opens without a delay and switches the heating off.

Alarm and fault indications are displayed by LEDs and an alarm can be simulated by pressing a button.

Technical data

Supply voltage

24 VDC +/- 20%, 0.3 A; SELV / PELV / CLASS2
100 – 240 VAC +10 / -15%, 47 – 63 Hz, 0.2 A (optional)

Fuse

External 0.5A; UL category JDYX, e.g., RND 170-00012

Power consumption

7 W

Response sensitivity

 [Water conductivity at 77 °F (25 °C)]

> 5 ... < 5000 ppm (> 10 ... < 10000 µS/cm)

Level electrode connection

1 input for NRG 1...-50 level electrode, 4-pole with shield.

Safety circuit

2 volt-free NO contacts, 6 A 250 V AC / 30 V DC $\cos \varphi = 1$.

Off delay 3 seconds.

Inductive loads must have interference suppression (RC combination) as specified by the manufacturer.

Signal output

2 volt-free outputs for external signaling without delay, 24 V DC, max. 100 mA (semiconductor output).

Indicators and controls

2 buttons for testing and diagnosis,

2 red/green LEDs for indicating operating state and alarm.

3 red LEDs for diagnosis.

Terminal box

Terminal box material: base of black polycarbonate, front of gray polycarbonate

Wire size: 1 x AWG12 (4.0 mm²) solid, or

1 x AWG14 (2.5 mm²) stranded with sleeve acc. to DIN 46228, or

2 x AWG16 (1.4 mm²) stranded with sleeve acc. to DIN 46228

Terminal strips can be removed separately

Terminal box attachment: Mounting clip on support rail TH 35, EN 60715

Electrical safety

Pollution degree 2, overvoltage category II according to UL 60730-1

Protection

Terminal box: IP 40 according to EN 60529

Terminal strip: IP 20 according to EN 60529

As a UL open type, the equipment must be installed in a control cabinet.

Weight

Approx. 1.1 lb (0.5 kg)

Ambient temperature

at power-on 32 ° ... 131 °F (0 ° ... 55 °C)

in operation 14 ° ... 131 °F (-10 ° ... 55 °C)

Transport temperature

-4 ° ... 176 °F (-20 ° ... +80 °C) (<100 hours), only switch on after a defrosting period of 24 hours.

Storage temperature

-4 ° ... 158 °F (-20 ° ... +70 °C), only switch on after a defrosting period of 24 hours.

Relative humidity

Max. 95%, non-condensing

Site altitude





Max. 6560 ft (2000 m)

Other information

■ Incorporated Type 2 action protective control Class B (C)

■ Pollution degree 2, impulse voltage 2500 V

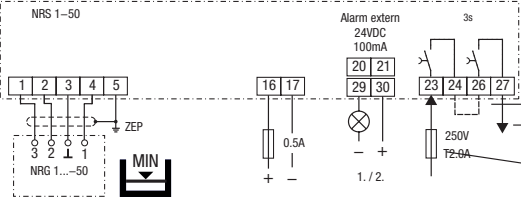
Rating plate, identification

Safety information	 Betriebsanleitung beachten See installation instructions Voir instructions de montage	NRS 1-50 — Type designation			
		24V $\pm 20\%$	7W	IP40 (IP20)	Mains voltage / Protection
Wiring diagram		Tamb = 7131°F (55°C)			Ambient temperature / Sensitivity
		Alarm extern 24VDC 100mA 3s Jumper, provided by customer Safety circuit Fuse, provided by customer			
Manufacturer	Protective Control Class B (C) acc. UL60730-1	Wasserstandbegrenzer Water level limiter Limiteur de niveau d'eau		CE	Type approval number
	GESTRA AG Münchener Str. 77 28215 Bremen Made in Germany	Serial number			Disposal information





Safety information	 Betriebsanleitung beachten See installation instructions Voir instructions de montage	NRS 1-50 — Type designation			
		100-240V \sim -15 / +10%	7W	IP40 (IP20)	Mains voltage / Protection
Wiring diagram		Tamb = 7131°F (55°C)			Ambient temperature / Sensitivity
		Alarm extern 24VDC 100mA 3s Jumper, provided by customer Safety circuit Fuse, provided by customer			
Manufacturer	Protective Control Class B (C) acc. UL60730-1	Wasserstandbegrenzer Water level limiter Limiteur de niveau d'eau		CE	Type approval number
	GESTRA AG Münchener Str. 77 28215 Bremen Made in Germany	Serial number			Disposal information

Fig. 1

 OPERATING CONTROL ES13189	Input rating: 24VDC, 7W
	Output rating : Pilot duty B300 / R300
	Ambient temperature: 32-131°F (0-55°C)
	Wiring: Use Copper Conductors Only, Use 60/75°C Conductors, Use No.18-16 AWG Wire Size Only, Tightening: Torque 0.79Nm or 7lb in.
	Use with accessory: NRG 16,17,19,111-11,-50,-50(F),NRG 16-36

 OPERATING CONTROL ES13189	Input rating: 100-240VAC, 7W
	Frequency: 50/60Hz Output rating : Pilot duty B300 / R300
	Ambient temperature: 32-131°F (0-55°C)
	Wiring: Use Copper Conductors Only, Use 60/75°C Conductors, Use No.18-16 AWG Wire Size Only, Tightening: Torque 0.79Nm or 7lb in.
	Use with accessory: NRG 16,17,19,111-11,-50,-50(F), NRG 16-36

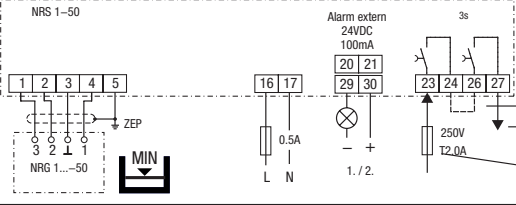
Fig. 2

Factory default settings

Level switch NRS 1-50

The level switch is delivered with the following factory default settings:

- Off delay: 3 s



DANGER



There is a risk of electric shock during work on electrical systems.

- Switch off the voltage to the plant before you install the equipment.
- Check that the plant is not carrying live voltage before commencing work.

Dimensions of the NRS 1-50

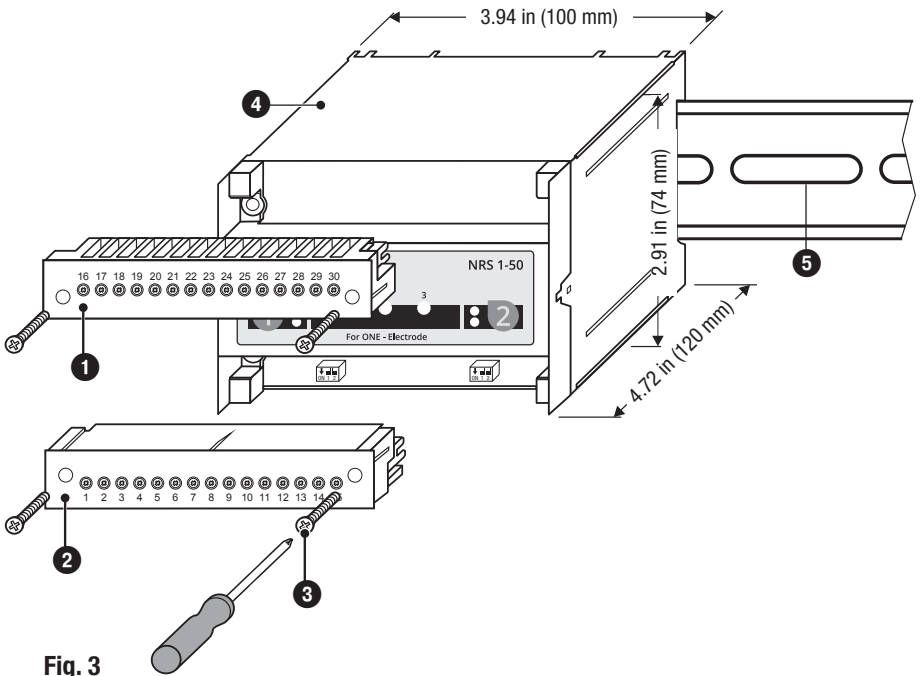

Fig. 3

Key

- 1 Upper terminal strip
- 2 Lower terminal strip
- 3 Fastening screws (cross recess head screw M3)
- 4 Terminal box
- 5 Support rail TH 35, EN 60715

Important notes

Safety information

The equipment is a protective control according to UL 60730-1 and may only be installed, electrically connected and brought into service by qualified and competent staff.

Fitting and maintenance work may only be performed by authorized staff who have undergone specific training.



Danger

The terminal strips of the equipment are live during operation!
There is a risk of serious injury due to electric shock.
Always **cut off power** to the equipment before working on the terminal strips (installation, removal, connecting cables).



Attention

The rating plate indicates the technical features of the equipment. Do not bring into service or operate any equipment that does not bear its own specific rating plate.



Attention

Pay attention to regulations in your country, e.g., NEC, NFPA, CEC, when using this equipment.

Preparing for installation



If the control cabinet is to be installed outdoors, outside the protection of a building, environmental influences may adversely affect function.

- Pay attention to the admissible ambient conditions in the technical data, see page 1712.
 - Do not operate the equipment if the temperature is below freezing.
 - ◆ At temperatures below freezing, use a suitable heat source (e.g., control cabinet heater, etc.).
 - Connect all parts of the plant to a central grounding point to prevent equalizing currents.
 - Use UV-resistant cable ducts for routing the connecting cable.
 - Take further measures to protect the equipment from lightning, insects and animals, and salty air.
-

You will need the following tools:

- Pozidriv screwdriver size PZ1

ATTENTION



Incorrect installation can lead to malfunctions in the plant or the level electrode.

The NRS 1-50 level switch snaps onto a TH 35, EN 60715 support rail in a control cabinet. **Fig. 3** 

Electrical connection

Supply voltage

Please provide the NRS 1-50 level switch with an external 0.5A fuse.

Connecting the level electrode

Please use the following to connect the level electrode(s):

- A shielded, multi-core TC-ER control cable with a minimum wire size of AWG18, e.g., OELFLEX CONTROL TM CY 5G1. Max. length 328 ft (100 m).

Wire the terminal strip as shown in the wiring diagram. **Fig. 4.** Connect the shields to terminal 5 and to the central grounding point (**CGP**) in the control cabinet.

Connecting the safety circuit

Please connect the safety circuit for the heating to terminals 23, 24 and 26, 27. If using the equipment as a water level limiter, please connect the output contacts of the two monitoring channels by adding a wire jumper between terminals 24 and 26.

Provide the output contacts with a slow blow T1A fuse.



Note

- In the event of an alarm, the NRS 1-50 level switch interlock does not take place automatically.
If the installation requires an interlock, this must be implemented in the downstream (safety) circuit.
- In order to guarantee Class C function with second fault protection in accordance with UL 60730-1, both signaling outputs must be monitored during interlock deactivation, see **Fig. 5.**
- It is important that the interlock is not deactivated when the level switch signals a malfunction to the diagnostic LEDs or the signaling outputs.

Electrical connection

Connecting the signal output

A signal output for connecting further external signaling devices, maximum load 100 mA, is allocated to each monitoring channel in the level switch. For connection, please use a control cable, e.g., 2 x AWG20 (0.5 mm²). In the event of alarm and fault indications, the signal output (terminals 20, 21, 29 and 30) closes without a delay.



Danger

- A safety power supply unit (SELV / PELV / CLASS2) must be used to supply the NRS 1-50 level switch with 24 V DC. This must provide a level of isolation against dangerous contact voltages that at least meets the requirements for double or reinforced insulation in accordance with UL 60730-1 (protective electrical isolation).



Attention

- Provide the NRS 1-50 level switch with an external 0.5A fuse.
- Connect the shields to terminal 5 and to the central grounding point (**CGP**) in the control cabinet.
- Provide the safety circuit with a slow blow T1A fuse to protect the switching contacts.
- Switching off inductive loads produces surges that can have a major adverse effect on open and closed-loop control systems. Connected inductive loads must therefore have interference suppression (RC combination) as specified by the manufacturer.
- Connect terminals 24 and 26 with a wire jumper.
- Route the connecting cables to the level electrode and the logic unit separately from power lines.
- Do not use unused terminals as support terminals.
- If, despite the necessary measures being taken, one of the signaling outputs is activated when a relay closes (terminals 23, 24 and 26, 27), there may be a dangerous second fault. Check the equipment and replace if necessary.

Electrical connection

Wiring diagram of level switch NRS 1-50

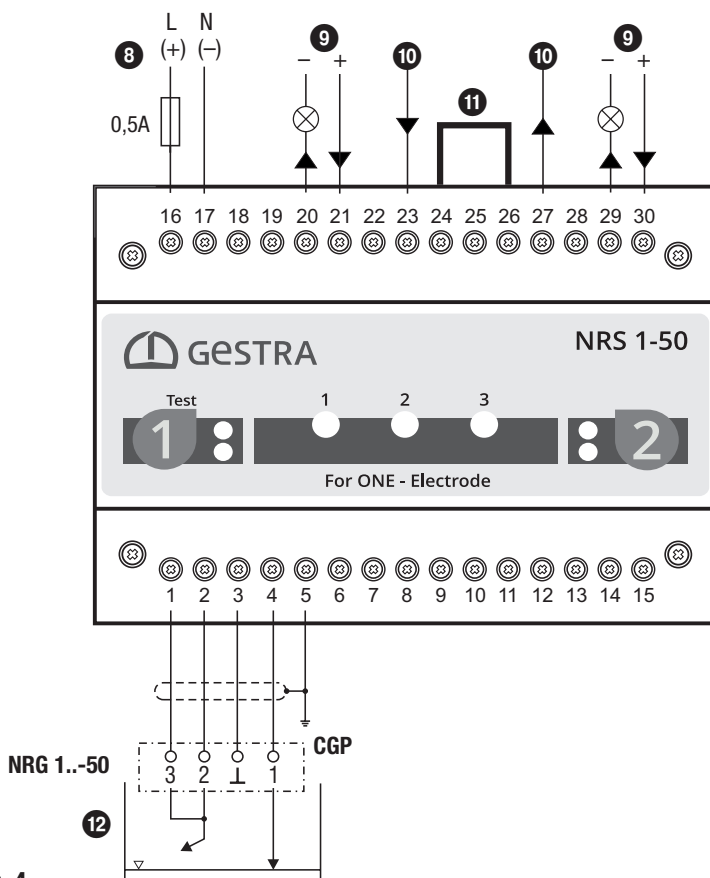

Fig. 4

Key

- 8 Supply voltage
 - 9 Signal output 1 / 2 for external alarm 24 V DC, 100 mA (semiconductor output)
 - 10 Safety circuit, input and output
 - 11 Wire jumper, provided by customer
 - 12 Level electrode NRG 1...-50
- CGP Central grounding point in control cabinet

Electrical connection

Connection example for Class C second fault protection with automatic prevention of interlock deactivation in the event of malfunction. The Reset button is acting to the external lockout reset function

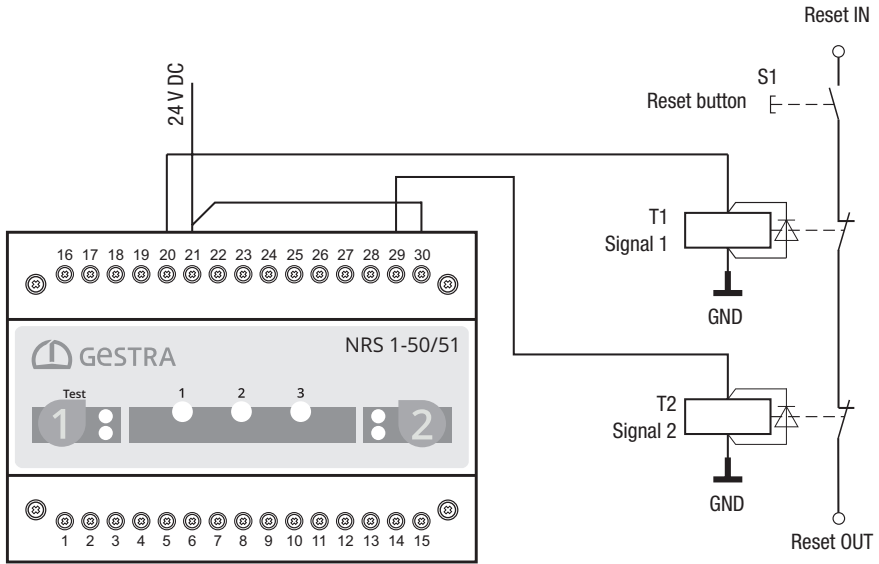
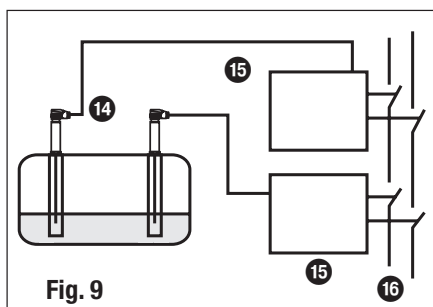
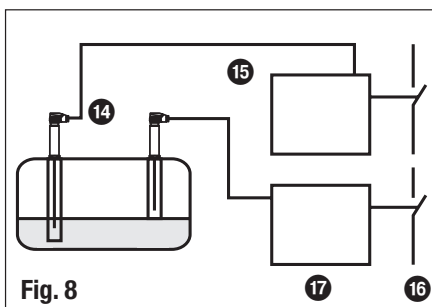
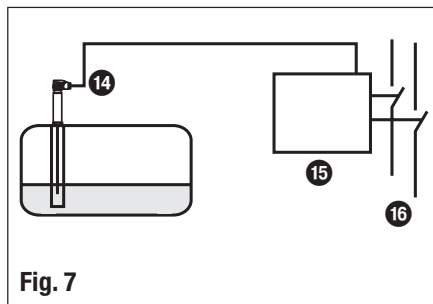
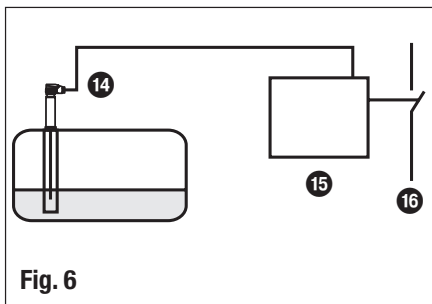

Fig. 5

Electrical connection

Example switching combinations



Key

- 14 Level electrode NRG 1...-50
- 15 Level switch NRS 1-50
- 16 Safety circuit
- 17 Level switch NRS 1-50 for advance low water alarm

Electrical connection

Key to example switching combinations

Steam boilers and hot water installations

Figure 6

Combination consisting of 1x NRG 1...-50 level electrode plus 1x NRS 1-50 level switch as a water level limiter.

For operation in accordance with ASME CSD-1, two mutually independent water level limiters must be used.

If they are deployed outside the boiler, they must be installed in independent level pots with a connection below the minimum water mark. The use of a single steam pipe is permitted.

For automatically fired hot water installations, cut-off must be initiated by a water level limiter.

As hot water boilers do not have a normal water mark, the water level limiter must be installed in such a way that it can detect the lowest admissible water level.

For further uses, please refer to the regulations in your country

Figure 7

Combination consisting of 1x NRG 1...-50 level electrode plus 1x NRS 1-50 level switch as a water level limiter.

The level switch opens two separate safety circuits.

Figure 8

Combination consisting of 1x NRG 1...-50 level electrode plus 1x NRS 1-50 level switch as a water level limiter and 1x NRG 1...-50 level electrode plus 1x NRS 1-50 level switch as an advance low water alarm.

Figure 9

Combination consisting of 2x NRG 1...-50 level electrodes plus 2x NRS 1-50 level switches as water level limiters.

The level switches open two separate safety circuits.

Bringing into service

Checking the switchpoint and function

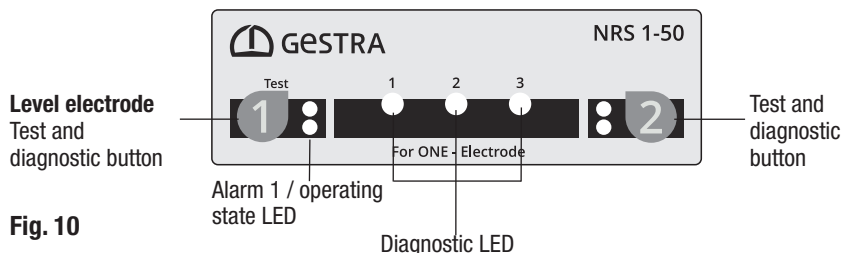

Fig. 10

Starting		
Action	Indication	Function
Switch on mains supply.	All LEDs light up	System is started and tested, approx. duration 10 s. Output contacts open. Signal output closed.
	All LEDs light up for more than 10 s	System error. Possible causes: Supply voltage error, faulty level switch.
Fill boiler until water is above low water (LW) level. Level electrode is immersed.	Green level electrode LED lights up	Output contacts closed, signal output open.

Checking the switchpoint and function		
Drain water until it is below the low water (LW) level. Level electrode is exposed	Red level electrode LED flashes	Off delay is in progress, signal output closes without a delay.
	Red level electrode LED lights up	Delay has elapsed, output contacts open. Signal output closed.

Possible errors during installation		
Status and display	Error	Corrective action
Water below low water (LW) switchpoint according to sight glass, but red level electrode LED is not lit! Safety circuit closed.	Electrode rod is too long.	Cut electrode rod in line with LW switchpoint.
	For internal installation: Upper pressure relief hole in protective tube is missing or obstructed.	Check level electrode installation and make sure that the level in the protective tube corresponds to the actual water level.
Water level sufficient. Red level electrode LED lights up! Safety circuit open.	Electrode rod is too short.	Replace electrode rod and cut a new one in line with LW switchpoint.
	Ground connection to tank is interrupted.	Clean sealing surfaces and screw in level electrode with metal sealing ring. Do not insulate with hemp or PTFE tape.
	Electrical conductivity of boiler water is too low.	Use an enlarged measuring surface for the level electrodes.
	Upper pressure relief hole is flooded.	Check level electrode installation and make sure that the level in the protective tube corresponds to the actual water level.

Operation, alarm and testing

Indicators and operation

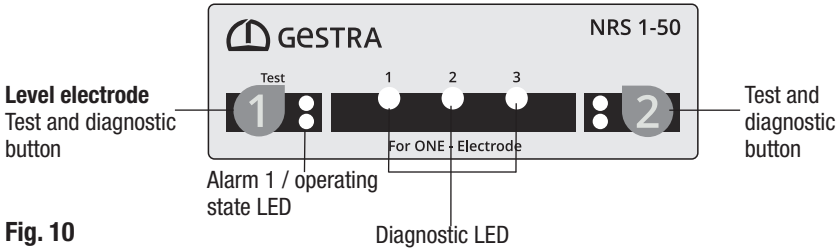

Fig. 10

Operation		
Action	Indication	Function
Level electrode immersed	Green level electrode LED lights up	Output contacts closed, signal output open.
Alarm		
Level electrode exposed, water is below low water (LW) level	Red level electrode LED flashes	Off delay is in progress, signal output closes without a delay.
	Red level electrode LED lights up	Delay has elapsed, output contacts open. Signal output closed.
Channel 1 test		
In operating mode: Press button 1 and hold until the end of the test. The level switch must behave as if there were an alarm.	Red level electrode LED flashes	Alarm simulation in channel 1. Off delay is in progress, signal output closes without a delay.
	Red level electrode LED lights up	Delay has elapsed, output contacts open. Signal output closed. Test is complete.
If the test is failed, replace the level switch.		

Fault indications and troubleshooting



Attention

Please check the following before fault diagnosis:

Supply voltage:

Is the level switch supplied with the mains voltage specified on the rating plate?

Wiring:

Does the wiring conform to the wiring diagram and your chosen switching combination?

Fault indication			
Status	Diagnosis	Function	Next action
Error on level electrode evaluation, channel 1	Diagnostic LED 1 and Alarm 1 LED light up	Output contacts open without a delay. Signal output closes without a delay.	Next: Press button 1
Error detected in level switch	Diagnostic LED 3 and Alarm 1 or 2 LED light up	Output contacts open without a delay. Signal output closes without a delay.	Next: Press button 1 or button 2

Diagnosis			
Indication 1 and action	Indication 2	Error	Corrective action
Alarm 1 LED and diagnostic LED 1 light up. Press and hold button 1	Diagnostic LED 1 flashes	Error in level electrode, error in level switch, wiring error, measuring voltage error.	<ul style="list-style-type: none"> – Check wiring, – measure electrode voltages, – clean level electrode, replace if necessary, – replace level switch.
	Diagnostic LED 2 flashes	Error in level electrode, error in level switch, wiring error.	
	Diagnostic LED 3 flashes	External voltage error, boiler wall has no PE.	Provide shielding and grounding, connect boiler to PE.
Alarm 1 or 2 LED and diagnostic LED 3 light up, press and hold button 1 or 2	Diagnostic LED 1 flashes	Processor error, standby error.	Replace level switch.
	Diagnostic LED 2 flashes	Internal voltage error.	
	Diagnostic LED 3 flashes	Relay error.	
Once the error has been rectified, the level switch reverts to normal operation. After troubleshooting, please switch the supply voltage off and on again after approx. 5 s.			

Checking the level electrode

Measuring level switch voltages

Measuring electrode voltages on the level switch enables you to check whether the level electrode is immersed or whether a fault is present. Please pay attention to **Fig. 11**.

U_{2-4}	U_{3-4}		U_{2-3}
	immersed	exposed	fault (immersed/alarm)
$\approx 0.7\text{ V}$ 85 Hz!	$< \frac{U_{2-4}}{2}$	$\geq \frac{U_{2-4}}{2}$	$\leq U_{3-4}$

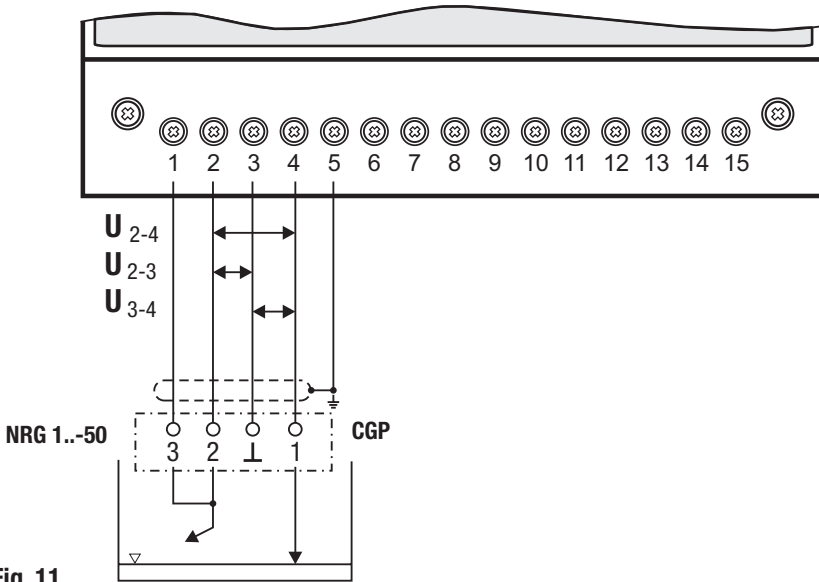

Fig. 11

Key

CGP Central grounding point in control cabinet



Note

- The self-test of the NRS 1-50 level switch cyclically reduces U_{2-4} , possibly to 0 V.

Further information

Action against high-frequency interference

High-frequency interference can be caused by out-of-phase switching operations. If such interference occurs and results in sporadic failure, we recommend taking the following action to suppress interference:

- Provide inductive loads with RC combinations as specified by the manufacturer.
- Route the connecting cable to the level electrode separately from power lines.
- Increase the distance from sources of interference.
- Check the connection of the shield to the central grounding point (**CGP**) in the control cabinet.
- Suppress HF interference using hinged-shell ferrite rings.

Interlock and interlock deactivation

In the event of an alarm, the NRS 1-50 level switch interlock does not take place automatically. If the installation requires an interlock, this must be implemented in the external (safety) circuit. It is important that the interlock is not deactivated when the level switch signals a malfunction to the diagnostic LEDs or the signaling outputs.

In order to guarantee Class C function with second fault protection in accordance with UL 60730-1, both signaling outputs must be monitored during interlock deactivation. To conform with ASME CSD-1 two low water level limiters are required. Connection example for Class C protection against second faults, see **Fig. 5** on page 22.

Checking switchpoints

The “Below low water (LW)” switchpoint can only be checked by reducing the water level. The level switch must then trigger an alarm and, after the off delay, it must open the safety circuit. The heating cut-off is interlocked in the (external) safety circuit and this interlock can only be deactivated again when the level electrodes are immersed once more. For this to happen, the Alarm 1 LED must light up and no errors should be indicated (diagnostic LEDs are not lit). Please carry out the switchpoint check when bringing the equipment into service, whenever the level electrodes have been replaced, and at regular intervals, e.g., once a year.

Taking out of service

Proceed as follows:

- Switch off the mains supply and **switch off the voltage to the equipment.**
- Unscrew the fastening screws on the right and left and detach the upper and lower terminal strips **Fig. 3 ① ② ③**.
- Release the white slider holder at the bottom of the unit and detach the unit from the support rail

Disposal

Dispose of the level switch in accordance with statutory waste disposal regulations.

UL components

The NRS 1-50 level switch is registered under XACN.E513189.

For your notes



You can find our authorized agents around the world at: www.gestra.com

GESTRA AG

Münchener Straße 77

28215 Bremen

Germany

Tel. +49 421 3503 0

Fax +49 421 3503 393

e-mail info@de.gestra.com

Web www.gestra.com