

# GESTRA

Rapid-action intermittent blowdown  
valve

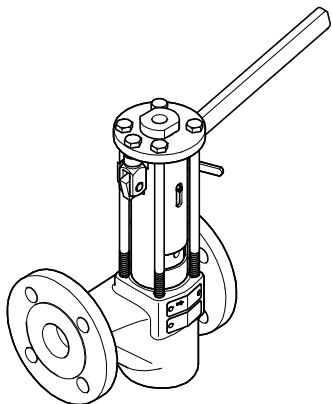

**PA 46**

**PA 47**

**MPA 46**

**MPA 47**

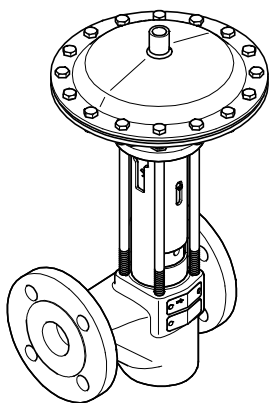

**EN**  
English

Original Installation Instructions  
**818447-02**

## Technical data

### Dimensions and weights

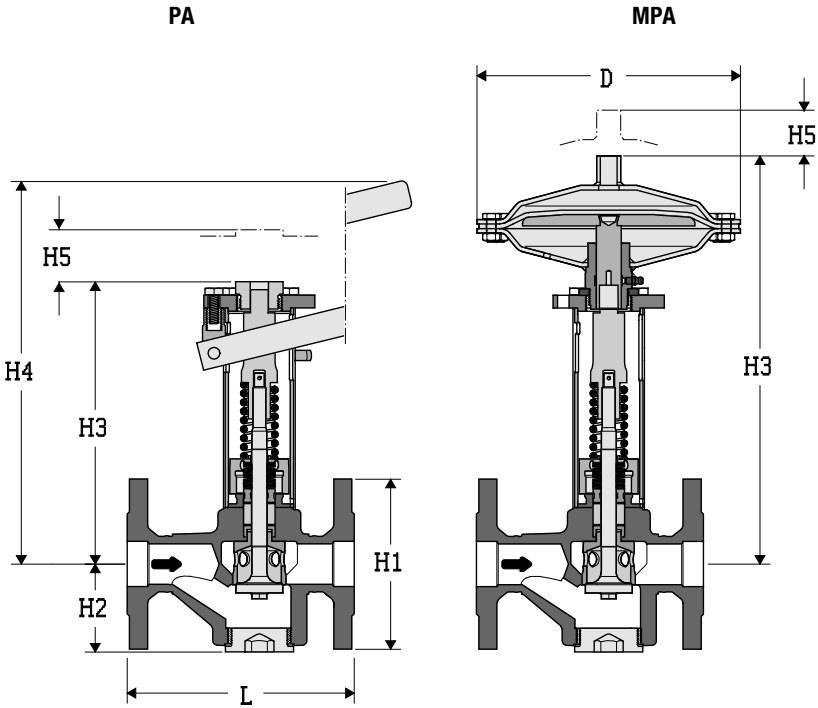

Dimension	PA	MPA
Ø D [mm]	–	235
H1 [mm]	See tables below	
H2 [mm]	DN 20-32: 55 mm DN 40/50: 80 mm	DN 20-32: 55 mm DN 40/50: 80 mm
H3 [mm]	250	360
H4 [mm]	350	–
H5 (space required for removing pressure plate) [mm]	25	25
L [mm]	See tables below	

Leave sufficient space for servicing. When the equipment is securely installed, a minimum space of 150 mm is required for removing or subsequently installing the actuator!

**PA 46/MPA 46, PN 40 flange**

DN	[mm]	20	25	32	40	50
	[in]	¾	1	1¼	1½	2
H1	[mm]	105	115	140	150	165
L	[mm]	150	160	180	200	230
Weight of PA	[kg]	8.8	9.3	10.6	13.8	15.6
Weight of MPA		13.2	13.7	15.0	18.2	20.0

**PA 46/MPA 46, CLASS 150 flange**

DN	[mm]	20	25	32	40	50
	[in]	¾	1	1¼	1½	2
H1	[mm]	98.4	107.9	117.5	127.0	152.4
L	[mm]	150	160	180	230	230
Weight of PA	[kg]	8.8	9.3	10.6	13.8	15.6
Weight of MPA		13.2	13.7	15.0	18.2	20.0

**PA 46/MPA 46, CLASS 300 flange**

DN	[mm]	20	25	32	40	50
	[in]	¾	1	1¼	1½	2
H1	[mm]	117.5	123.8	133.3	155.6	165.1
L	[mm]	150	160	180	230	230
Weight of PA	[kg]	8.8	9.3	10.6	13.8	15.6
Weight of MPA		13.2	13.7	15.0	18.2	20.0

**PA 46/MPA 46, butt-weld end,**

**EN 12627 but with joint type ISO 9692-1 code no. 1.3 (30° chamfer), DIN 2559-2**

DN	[mm]	20	25	32	40	50
	[in]	¾	1	1¼	1½	2
For tube	[mm]	26.9×2.3	33.7×2.6	42.4×3.6	48.3×2.6	60.3×3.2
L	[mm]	200	200	200	250	250
Weight of PA	[kg]	8.2	8.2	8.9	12.0	13.3
Weight of MPA		12.6	12.6	13.3	16.4	17.7