

Solenoid valve(5/2 way, 5/3 way)

4V100 Series

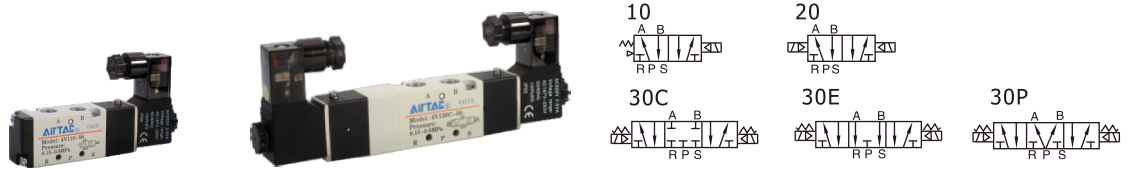

Ordering code

4V 1 10 06 A □ T

① ② ③ ④ ⑤ ⑥ ⑦

① Model

4V: Solenoid valve
(5/2, 5/3 way)

② Code

1: 100 Series

③ Valve type

10: Single solenoid 5/2 way
20: Double solenoid 5/2 way
30C: Double solenoid 5/3 way
closed center
30E: Double solenoid 5/3 way
exhaust center
30P: Double solenoid 5/3 way
pressure center

④ Port size

M5: M5
06: 1/8"

⑤ Voltage

A: AC220V
B: DC24V
C: AC110V
E: AC24V
F: DC12V

⑥ Electrical entry

Blank: Terminal
I: Flying leads

⑦ Thread type

No this code(M5)
T: NPT

[Note]: The wire length is 0.5m.

Please refer to 84 for manifold specification and the order way.

Specification

Model	4V110-M5 4V120-M5	4V130C-M5 4V130E-M5 4V130P-M5	4V110-06 4V120-06	4V130C-06 4V130E-06 4V130P-06
Fluid	Air(to be filtered by 40μm filter element)			
Acting	Internal pilot or external pilot			
Port size [Note1]	In=Out=M5		In=Out=1/8"	
Orifice size [Note4]	4V110-06,4V120-06:10.2mm ² (Cv=0.6) 4V130C-06:8.6mm ² (Cv=0.51)			
Valve type	5 port 2 position	5 port 3 position	5 port 2 position	5 port 3 position
Operating pressure	21~114psi(0.15~0.8MPa)			
Proof pressure	175psi(1.2MPa)			
Temperature	-20~70°C			
Material of body	Aluminum alloy			
Lubrication [Note2]	Not required			
Max.frequency [Note3]	5 cycle/sec	3cycle/sec	5 cycle/sec	3 cycle/sec
Weight (g)	4V110-M5:120 4V120-M5:175	200	4V110-06:120 4V120-06:175	200

[Note1] NPT thread is available.

[Note2] Once lubricated air is used, continue with same medium to optimize valve life span.
Lubricants like ISO VG32 or equivalent are recommended.

[Note3] The maximum actuation frequency is in the no-load state.

[Note4] Equivalent orifice S and Cv are all calculated from the flow rate data.

Solenoid valve(5/2 way, 5/3 way)

4V100 Series

Coil specification

Item	specification				
Standard voltage	AC220V	AC110V	AC24V	DC24V	DC12V
Scope of voltage	AC: ±15%		DC: ±10%		
Power consumption	3.5VA	3.5VA	4.0VA	2.5W	2.5W
Protection	IP65(DIN40050)				
Temperature classification	B Class				
Electrical entry	Terminal, Flying leads				
Activating time	0.05 sec and below				

Inner structure

4V110

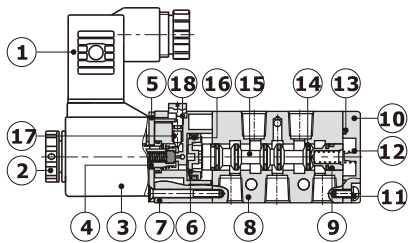

4V120

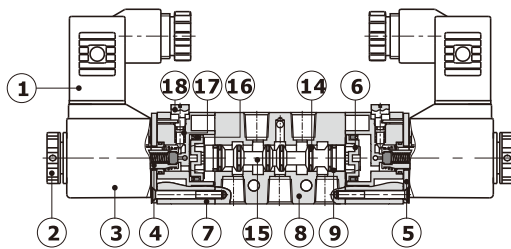

4V130C

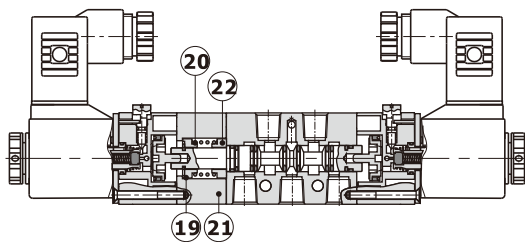

No.	Item	No.	Item	No.	Item
1	Connector	9	Wear ring	17	Override spring
2	Coil net	10	Bottom cover	18	Manual override
3	Coil	11	Fixed screw	19	Spring holder
4	Armature	12	Spool spring	20	Return spring
5	Fixed plate	13	Bottom cover gasket	21	Side cover
6	Piston	14	Spool O-ring	22	Spring holder
7	Pilot kit	15	Spool		
8	Body	16	Piston O-ring		

Product feature

1. Pilot-oriented mode: Internal pilot or external pilot.
2. Structure in sliding column mode: good tightness and sensitive reaction .
3. Three position solenoid valves have three kinds of central function for your choice.
4. Double control solenoid valves have memory function.
5. Internal hole adopts special processing technology which has little attrition friction, low start pressure and long service life.
6. No need to add oil for lubrication.
7. It is available to form integrated valve group with the base to save installation space.
8. Affiliated manual devices are equipped to facilitate installation and debugging.
9. Several standard voltage grades are optional.

Flow chart

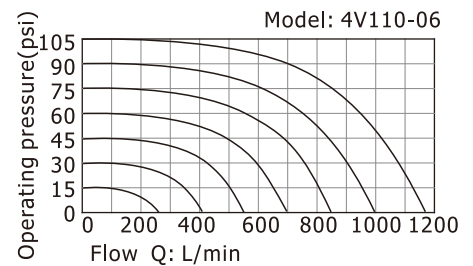

The data in flow rate chart are obtained from AirTAC lab.

Solenoid valve(5/2 way, 5/3 way)

4V100 Series

Dimensions

4V110(Terminal)

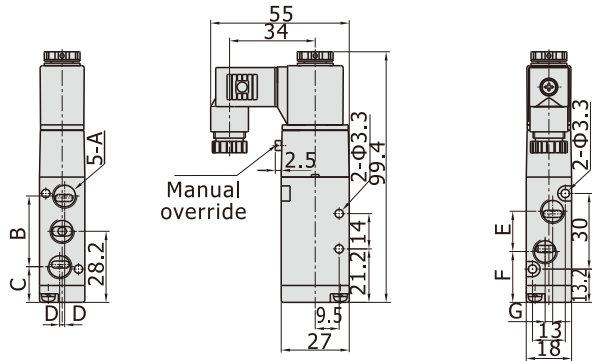

4V110(Flying leads)

[Unit: mm]

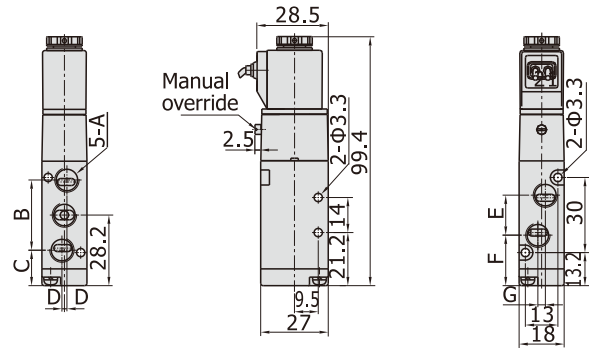

Model\Item	A	B	C	D	E	F	B
4V110-M5	M5x0.8	27	14.7	0	14	21.2	0
4V110-06	1/8"	28	14.2	1	16	20.2	3

4V120(Terminal)

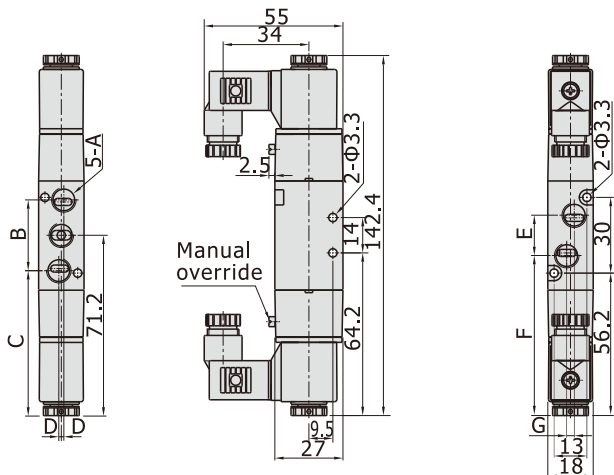

4V120(Flying leads)

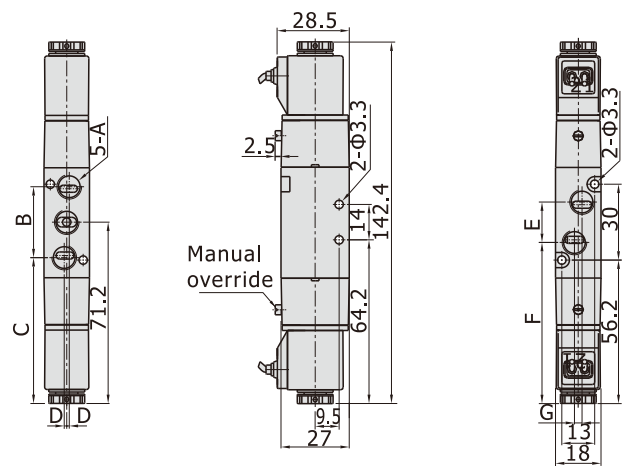

4V130(Terminal)

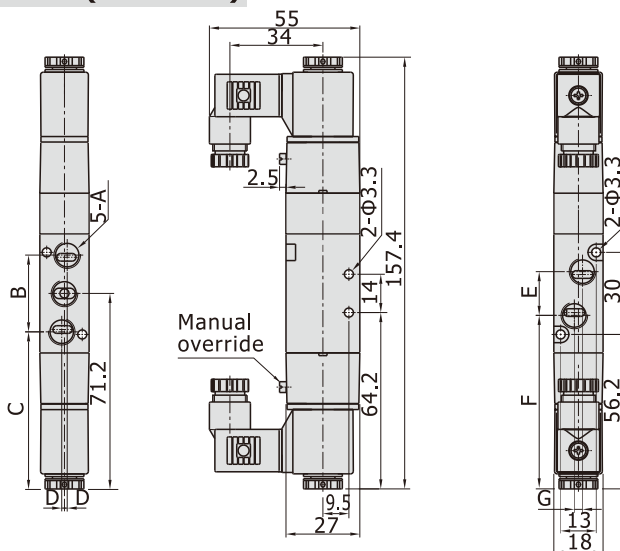

4V130(Flying leads)

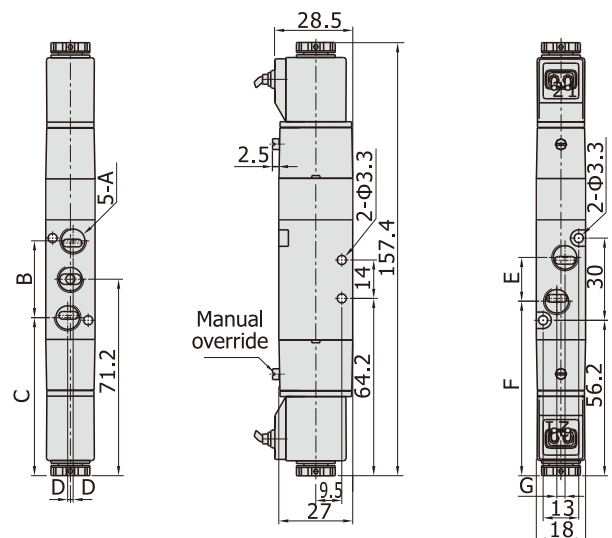

Model\Item	A	B	C	D	E	F	G	
4V120-M5	4V130-M5	M5x0.8	27	57.7	0	14	64.3	0
4V120-06	4V130-06	1/8"	28	57.2	1	16	63.2	3

Solenoid valve(5/2 way, 5/3 way)

4V200 Series

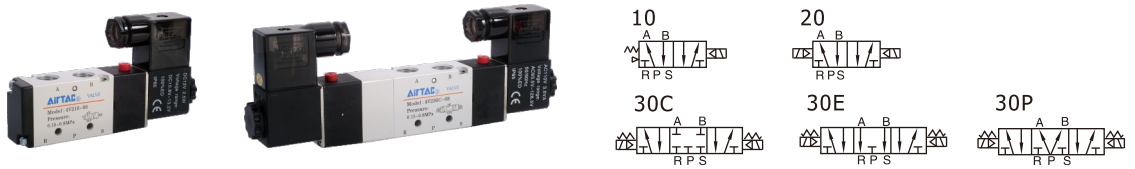

Ordering code

4V 2 10 08 A □ T

① ② ③ ④ ⑤ ⑥ ⑦

① Model

4V: Solenoid valve
(5/2, 5/3 way)

② Code

2: 200 Series

③ Valve type

10: Single solenoid 5/2 way
20: Double solenoid 5/2 way
30C: Double solenoid 5/3 way
closed center
30E: Double solenoid 5/3 way
exhaust center
30P: Double solenoid 5/3 way
pressure center

④ Port size

06: 1/8"
08: 1/4"

⑤ Voltage

A: AC220V
B: DC24V
C: AC110V
E: AC24V
F: DC12V

⑥ Electrical entry

Blank: Terminal
I: Flying leads

⑦ Thread type

T: NPT

[Note]: The wire length is 0.5m.

Please refer to 84 for manifold specification and the order way.

Specification

Model	4V210-06 4V220-06	4V230C-06 4V230E-06 4V230P-06	4V210-08 4V220-08	4V230C-08 4V230E-08 4V230P-08
Fluid	Air(to be filtered by 40µm filter element)			
Acting	Internal pilot or external pilot			
Port size [Note1]	In=Out=Exhaust=1/8"		In=Out=1/4" Exhaust=1/8"	
Orifice size [Note4]	4V210-08,4V220-08:17.0mm ² (Cv=1.0) 4V230C-08:13.6mm ² (Cv=0.8)			
Valve type	5 port 2 position	5 port 3 position	5 port 2 position	5 port 3 position
Operating pressure	21~114psi(0.15~0.8MPa)			
Operating pressure	175psi(1.2MPa)			
Temperature	-20~70°C			
Material of body	Aluminum alloy			
Lubrication [Note2]	Not required			
Max. frequency [Note3]	5 cycle/sec	3 cycle/sec	5 cycle/sec	3 cycle/sec
Weight (g)	4V210-06:220 4V220-06:320	360	4V210-08:220 4V220-08:320	360

[Note1] NPT thread is available.

[Note2] Once lubricated air is used, continue with same medium to optimize valve life span. Lubricants like ISO VG32 or equivalent are recommended.

[Note3] The maximum actuation frequency is in the no-load state.

[Note4] Equivalent orifice S and Cv are all calculated from the flow rate data.

Solenoid valve(5/2 way, 5/3 way)

4V200 Series

Coil specification

Item	specification				
Standard voltage	AC220V	AC110V	AC24V	DC24V	DC12V
Scope of voltage	AC: ±15%		DC: ±10%		
Power consumption	4.5VA	4.5VA	5.0VA	3.0W	3.0W
Protection	IP65(DIN40050)				
Temperature classification	B Class				
Electrical entry	Terminal, Flying leads				
Activating time	0.05 sec and below				

Inner structure

4V210

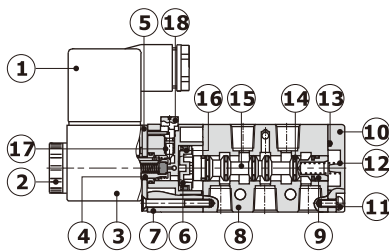

4V220

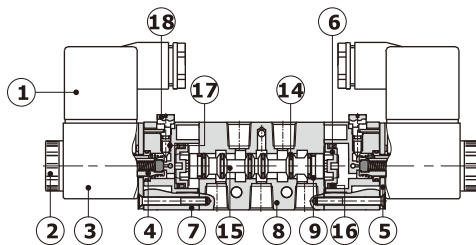

4V230C

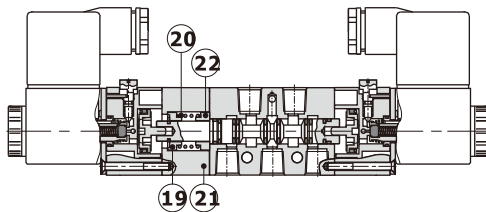

No.	Item	No.	Item	No.	Item
1	Connector	9	Wear ring	17	Override spring
2	Coil net	10	Bottom cover	18	Manual override
3	Coil	11	Fixed screw	19	Spring holder
4	Armature	12	Spool spring	20	Return spring
5	Fixed plate	13	Bottom cover gasket	21	Side cover
6	Piston	14	Spool O-ring	22	Spring holder
7	Pilot kit	15	Spool		
8	Body	16	Piston O-ring		

Product feature

1. Pilot-oriented mode: Internal pilot or external pilot.
2. Structure in sliding column mode: good tightness and sensitive reaction .
3. Three position solenoid valves have three kinds of central function for your choice.
4. Double control solenoid valves have memory function.
5. Internal hole adopts special processing technology which has little attrition friction, low start pressure and long service life.
6. No need to add oil for lubrication.
7. It is available to form integrated valve group with the base to save installation space.
8. Affiliated manual devices are equipped to facilitate installation and debugging.
9. Several standard voltage grades are optional.

Flow chart

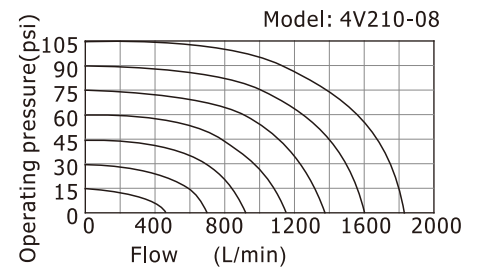

The data in flow rate chart are obtained from AirTAC lab.

Solenoid valve(5/2 way, 5/3 way)

4V200 Series

Dimensions

4V210(Terminal)

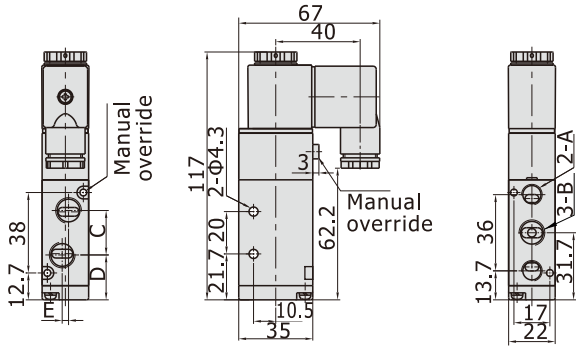

4V210(Flying leads)

[Unit: mm]

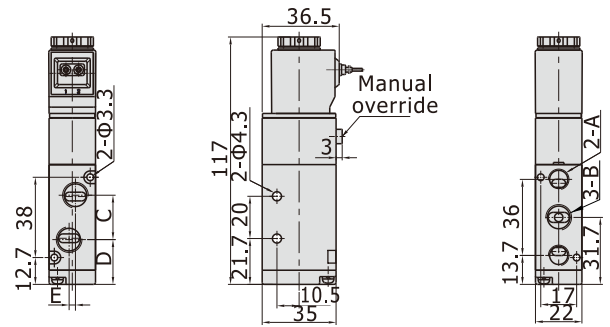

Model\Item	A	B	C	D	E
4V210-06	1/8"	1/8"	18	22.7	0
4V210-08	1/8"	1/4"	21	21.2	3

4V220(Terminal)

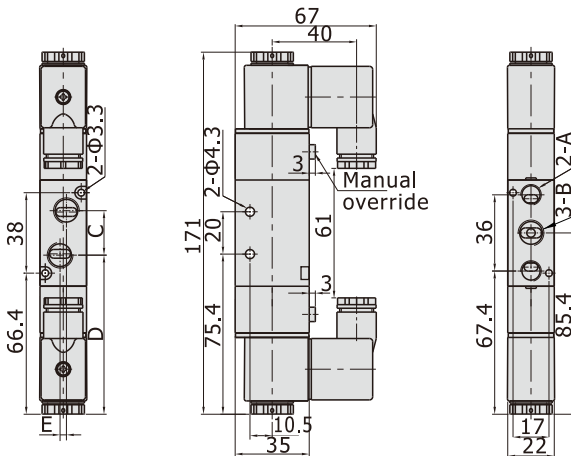

4V220(Flying leads)

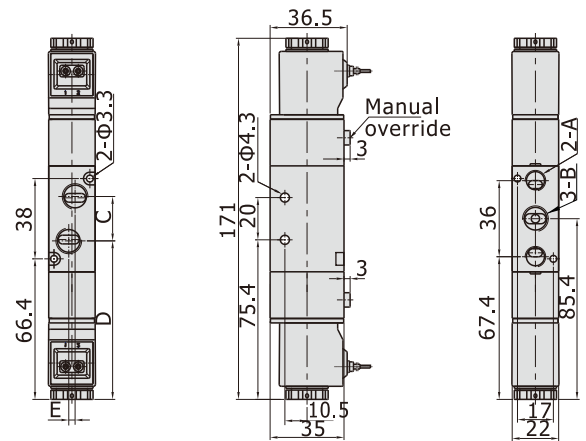

4V230(Terminal)

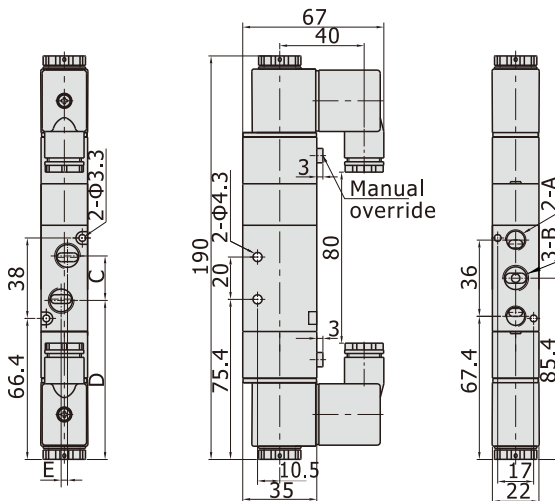

4V230(Flying leads)

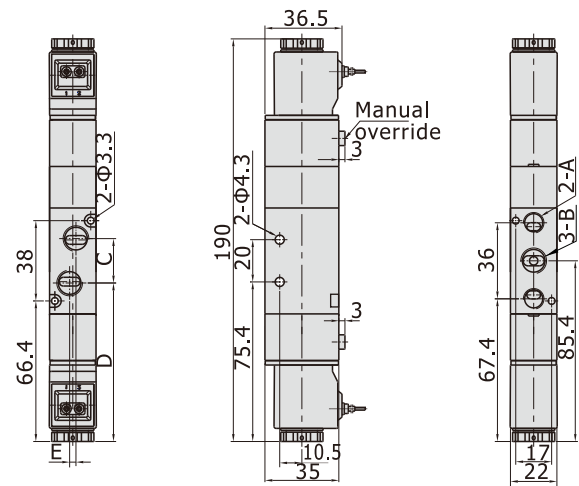

Model\Item	A	B	C	D	E	
4V220-06	4V230-06	1/8"	1/8"	18	76.4	0
4V220-08	4V230-08	1/8"	1/4"	21	74.9	3

Solenoid valve(5/2 way, 5/3 way)

4V300 Series



Ordering code

4V 3 10 10 A □ T

① ② ③ ④ ⑤ ⑥ ⑦

① Model

4V: Solenoid valve
(5/2, 5/3 way)

② Code

3: 300 Series

③ Valve type

10: Single solenoid 5/2 way
20: Double solenoid 5/2 way
30C: Double solenoid 5/3 way
closed center
30E: Double solenoid 5/3 way
exhaust center
30P: Double solenoid 5/3 way
pressure center

④ Port size

08: 1/4"
10: 3/8"

⑤ Voltage

A: AC220V
B: DC24V
C: AC110V
E: AC24V
F: DC12V

⑥ Electrical entry

Blank: Terminal
I: Flying leads

⑦ Thread type

T: NPT

[Note]: The wire length is 0.5m.

Please refer to 84 for manifold specification and the order way.

Specification

Model	4V310-08 4V320-08	4V330C-08 4V330E-08 4V330P-08	4V310-10 4V320-10	4V330C-10 4V330E-10 4V330P-10
Fluid	Air(to be filtered by 40μm filter element)			
Acting	Internal pilot or external pilot			
Port size [Note1]	In=Out=Exhaust=1/4"		In=Out=3/8" Exhaust=1/4"	
Orifice size [Note4]	4V310-10,4V320-10:28.0mm ² (Cv=1.65) 4V330C-10:21.3mm ² (Cv=1.25)			
Valve type	5 port 2 position	5 port 3 position	5 port 2 position	5 port 3 position
Operating pressure	21~114psi(0.15~0.8MPa)			
Proof pressure	175psi(1.2MPa)			
Temperature	-20~70°C			
Material of body	Aluminum alloy			
Lubrication [Note2]	Not required			
Max.frequency [Note3]	4 cycle/sec	3 cycle/sec	4 cycle/sec	3 cycle/sec
Weight (g)	4V310-08:310 4V320-08:400	450	4V310-10:310 4V320-10:400	450

[Note1] NPT thread is available.

[Note2] Once lubricated air is used, continue with same medium to optimize valve life span.
Lubricants like ISO VG32 or equivalent are recommended.

[Note3] The maximum actuation frequency is in the no-load state.

[Note4] Equivalent orifice S and Cv are all calculated from the flow rate data.

Solenoid valve(5/2 way, 5/3 way)

4V300 Series

Coil specification

Item	specification				
Standard voltage	AC220V	AC110V	AC24V	DC24V	DC12V
Scope of voltage	AC: ±15%		DC: ±10%		
Power consumption	4.5VA	4.5VA	5.0VA	3.0W	3.0W
Protection	IP65(DIN40050)				
Temperature classification	B Class				
Electrical entry	Terminal, Flying leads				
Activating time	0.05 sec and below				

Inner structure

4V310

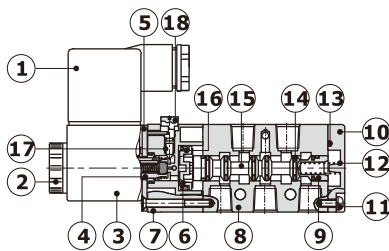

4V320

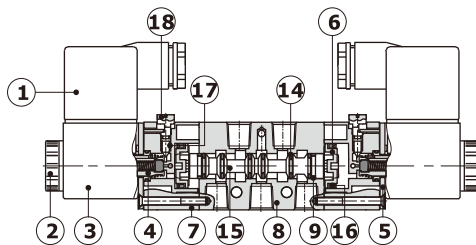

4V330C

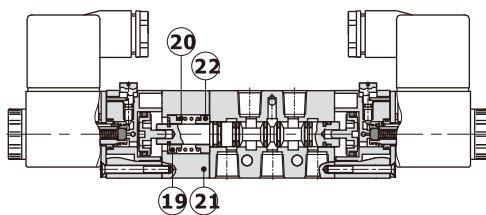

No.	Item	No.	Item	No.	Item
1	Connector	9	Wear ring	17	Override spring
2	Coil net	10	Bottom cover	18	Manual override
3	Coil	11	Fixed screw	19	Spring holder
4	Armature	12	Spool spring	20	Return spring
5	Fixed plate	13	Bottom cover gasket	21	Side cover
6	Piston	14	Spool O-ring	22	Spring holder
7	Pilot kit	15	Spool		
8	Body	16	Piston O-ring		

Product feature

1. Pilot-oriented mode: Internal pilot or external pilot.
2. Structure in sliding column mode: good tightness and sensitive reaction .
3. Three position solenoid valves have three kinds of central function for your choice.
4. Double control solenoid valves have memory function.
5. Internal hole adopts special processing technology which has little attrition friction, low start pressure and long service life.
6. No need to add oil for lubrication.
7. It is available to form integrated valve group with the base to save installation space.
8. Affiliated manual devices are equipped to facilitate installation and debugging.
9. Several standard voltage grades are optional.

Flow chart

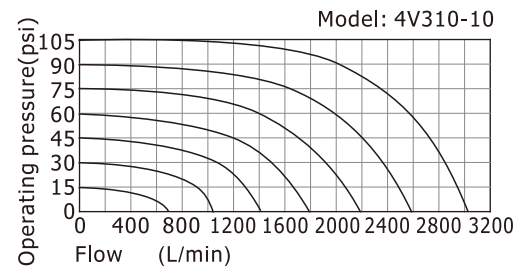

The data in flow rate chart are obtained from AirTAC lab.

Solenoid valve(5/2 way, 5/3 way)

4V300 Series

Dimensions

4V310(Terminal)

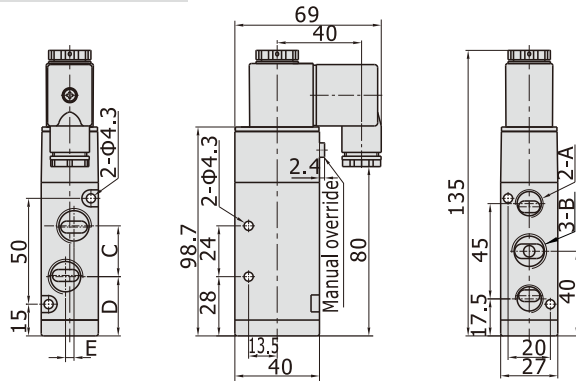

4V310(Flying leads)

[Unit: mm]

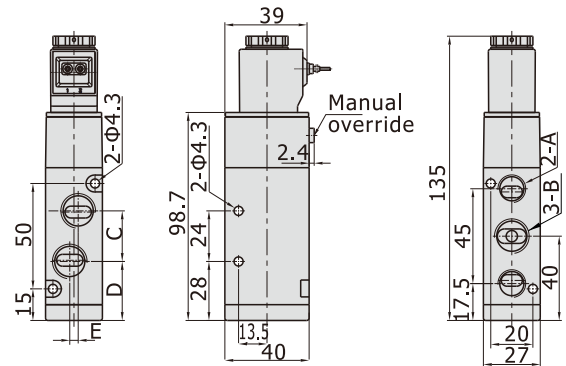

Model\Item	A	B	C	D	E
4V310-08	1/4"	1/4"	22	29	0
4V310-10	1/4"	3/8"	24	28	4

4V320(Terminal)

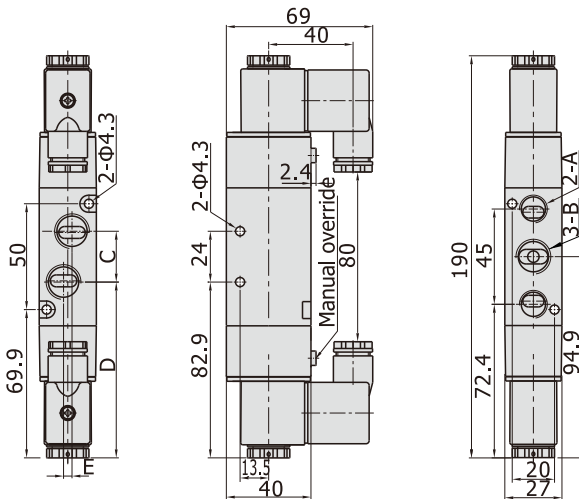

4V320(Flying leads)

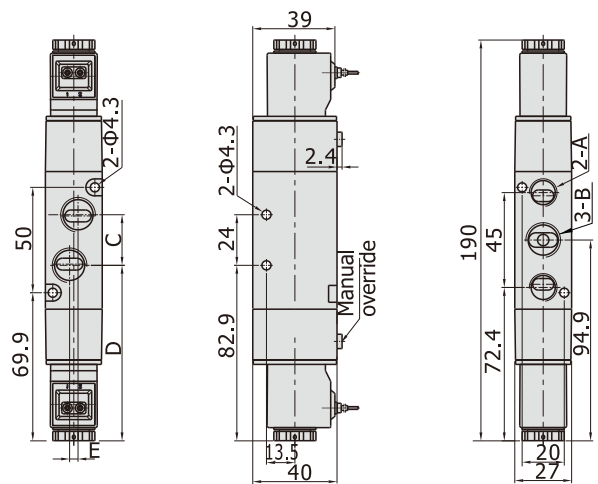

4V330(Terminal)

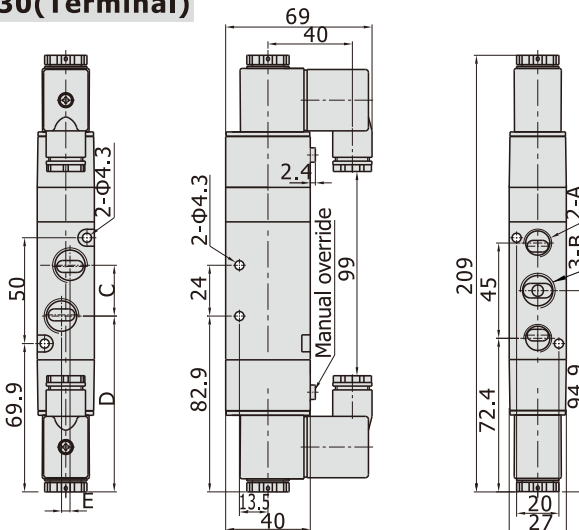

4V330(Flying leads)

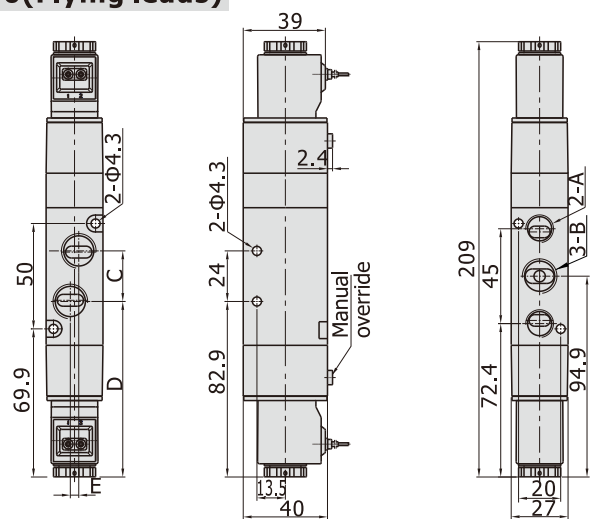

Model\Item	A	B	C	D	E	
4V320-08	4V330-08	1/4"	1/4"	22	83.9	0
4V320-10	4V330-10	1/4"	3/8"	24	82.9	4

Solenoid valve(5/2 way, 5/3 way)

4V400 Series



Ordering code

4V 4 10 15 A □ T

① ② ③ ④ ⑤ ⑥ ⑦

① Model

4V: Solenoid valve
(5/2, 5/3 way)

② Code

4: 400 Series

③ Valve type

10: Single solenoid 5/2 way
20: Double solenoid 5/2 way
30C: Double solenoid 5/3 way
closed center
30E: Double solenoid 5/3 way
exhaust center
30P: Double solenoid 5/3 way
pressure center

④ Port size

15: 1/2"

⑤ Voltage

A: AC220V
B: DC24V
C: AC110V
E: AC24V
F: DC12V

⑥ Electrical entry

Blank: Terminal
I: Flying leads

⑦ Thread type

T: NPT

[Note]: The wire length is 0.5m.

Please refer to 84 for manifold specification and the order way.

Specification

Model	4V410-15	4V420-15	4V430C-15	4V430E-15	4V430P-15
Fluid	Air(to be filtered by 40μm filter element)				
Acting	Internal pilot or external pilot				
Port size [Note1]	In=Out=Exhaust=1/2"				
Orifice size [Note4]	4V410-15,4V420-15:48.0mm ² (Cv=2.82) 4V430C-15:40.0mm ² (Cv=2.35)				
Valve type	5 port 2 position		5 port 3 position		
Operating pressure	21~114psi(0.15~0.8MPa)				
Proof pressure	175psi(1.2MPa)				
Temperature	-20~70°C				
Material of body	Aluminum alloy				
Lubrication [Note2]	Not required				
Max. frequency [Note3]	3 cycle/sec				
Weight (g)	590	720	770		

[Note1] NPT thread is available.

[Note2] Once lubricated air is used, continue with same medium to optimize valve life span. Lubricants like ISO VG32 or equivalent are recommended.

[Note3] The maximum actuation frequency is in the no-load state.

[Note4] Equivalent orifice S and Cv are all calculated from the flow rate data.

Solenoid valve(5/2 way, 5/3 way)

4V400 Series

Coil specification

Item	specification				
Standard voltage	AC220V	AC110V	AC24V	DC24V	DC12V
Scope of voltage	AC: ±15% DC: ±10%				
Power consumption	4.5VA	4.5VA	5.0VA	3.0W	3.0W
Protection	IP65(DIN40050)				
Temperature classification	B Class				
Electrical entry	Terminal, Flying leads				
Activating time	0.05 sec and below				

Inner structure

4V410

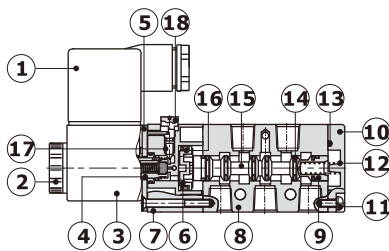

4V420

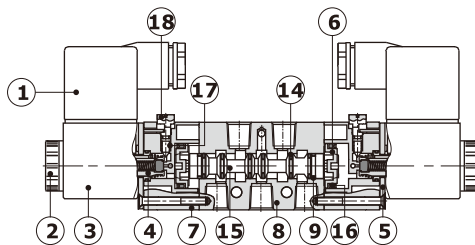

4V430C

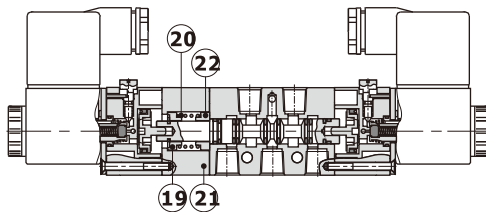

No.	Item	No.	Item	No.	Item
1	Connector	9	Wear ring	17	Override spring
2	Coil net	10	Bottom cover	18	Manual override
3	Coil	11	Fixed screw	19	Spring holder
4	Armature	12	Spool spring	20	Return spring
5	Fixed plate	13	Bottom cover gasket	21	Side cover
6	Piston	14	Spool O-ring	22	Spring holder
7	Pilot kit	15	Spool		
8	Body	16	Piston O-ring		

Product feature

1. Pilot-oriented mode: Internal pilot or external pilot.
2. Structure in sliding column mode: good tightness and sensitive reaction .
3. Three position solenoid valves have three kinds of central function for your choice.
4. Double control solenoid valves have memory function.
5. Internal hole adopts special processing technology which has little attrition friction, low start pressure and long service life.
6. No need to add oil for lubrication.
7. It is available to form integrated valve group with the base to save installation space.
8. Affiliated manual devices are equipped to facilitate installation and debugging.
9. Several standard voltage grades are optional.

Flow chart

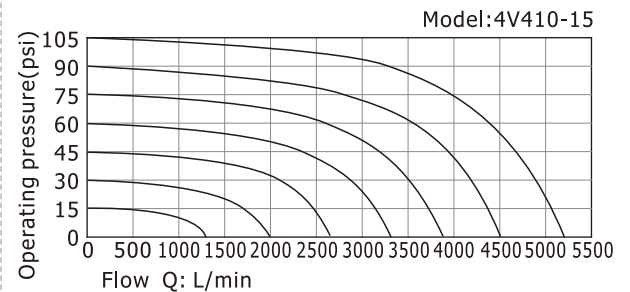

The data in flow rate chart are obtained from AirTAC lab.

Solenoid valve(5/2 way, 5/3 way)

4V400 Series

Dimensions

4V410(Terminal)

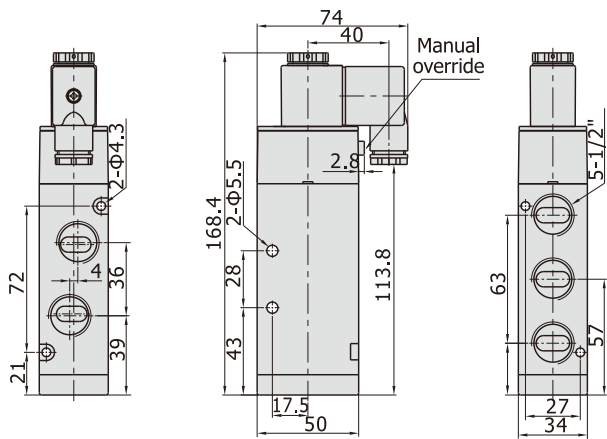

4V410(Flying leads)

[Unit: mm]

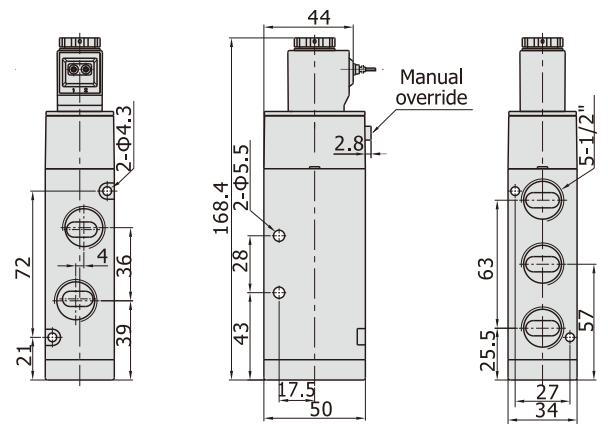

4V420(Terminal)

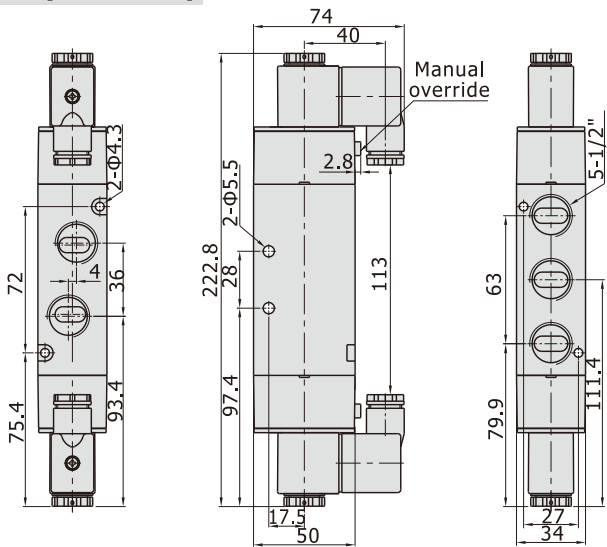

4V420(Flying leads)

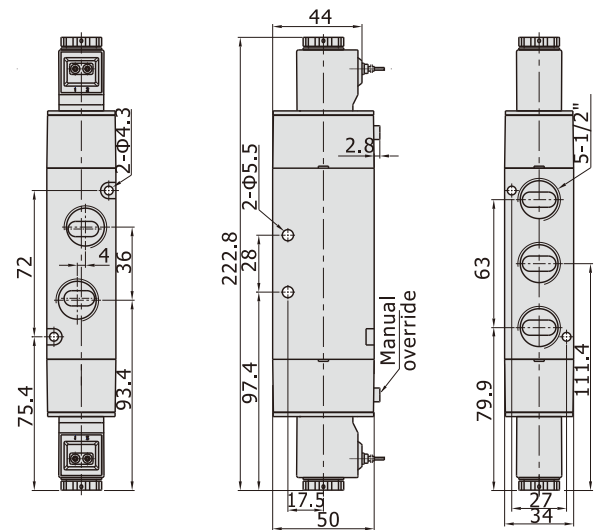

4V430(Terminal)

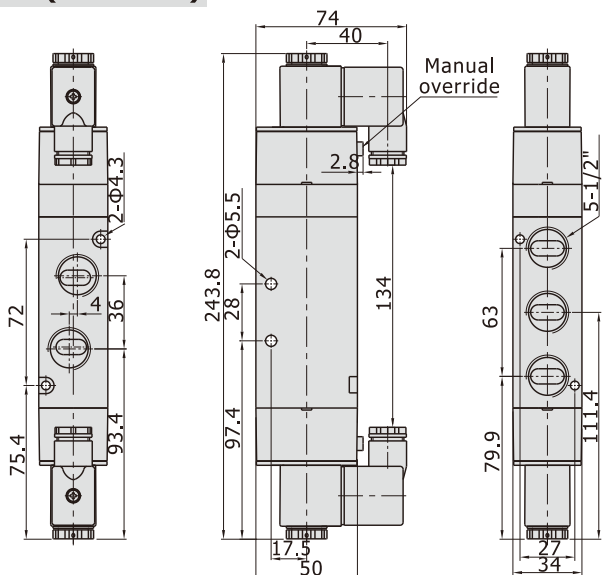

4V430(Flying leads)

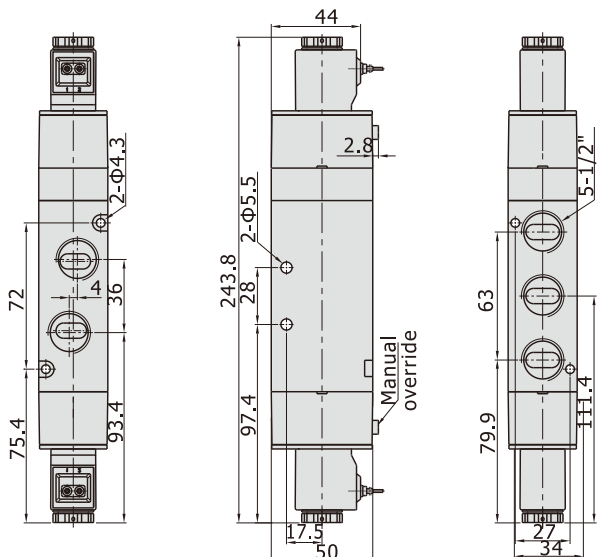

Manifold

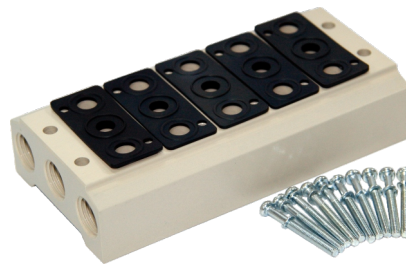

Ordering code

Ordering code for manifold

100M 5F T

① ② ③

① **Model**

100M: 100 Series manifold
200M: 200 Series manifold
300M: 300 Series manifold
400M: 400 Series manifold

② **Number of stations** [Note1]

1F: 1 station
2F: 2 station
3F: 3 station
.....
16F: 16 station

③ **Thread type**

T: NPT

Ordering code for blank plate

P-100M-R2

① ② ③

① **Kits**

P: Kits

② **Model**

100M: 100 Series manifold
200M: 200 Series manifold
300M: 300 Series manifold
400M: 400 Series manifold

③ **Code**

R2: Blank plate for manifold

[Note1] 100M, 200M series have a maximum of 16 stations ;
300M series have a maximum of 12 stations;
400M series have a maximum of 8 stations.

[Note] 1. Ordering code contains the two parts of the manifold's and the blank plate's.
2. Manifold kits contains manifold, seal and screw;
3. Blank plate kits contains blank plate and screw.

Specification

Item\Manifold Model	100M	200M	300M	400M
Fluid	Air(to be filtered by 40µm filter element)			
Temperature	-20~70°C			
Adaptable valve's series	4V100 Series	4V200 Series	4V300 Series	4V400 Series

Product feature

1. It is available to integrate the direction control valves of the same series to form valve group to save space and cost.
2. It is easy to examine when there are faults owing to the unified air intake and exhaust and unified wiring.
3. Flexible combination and strong expansion capability can make any combination or expansion of the numbers of direction control valves that are connected.

Manifold

Dimensions

With 4V solenoid valve

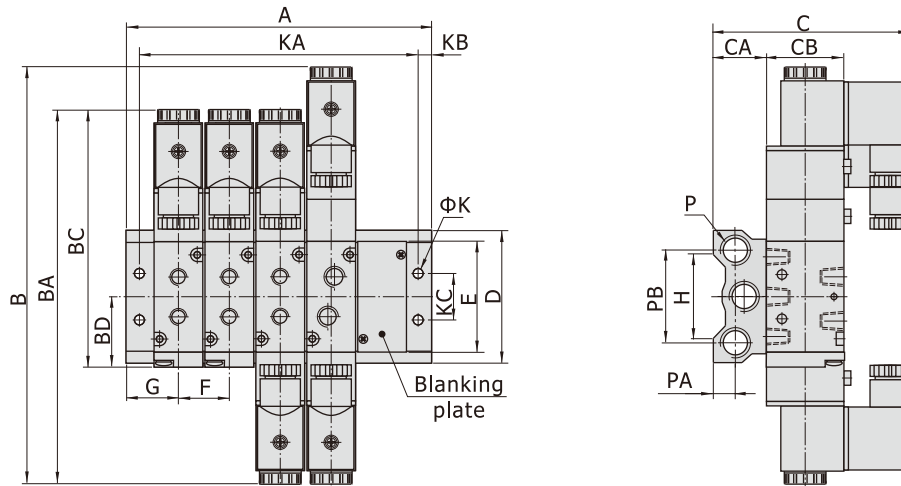

[Unit: mm]

Model\Item	B	BA	BC	BD	C	CA	CB	D	E	F	G	H	K	KB	KC	P	PA	PB
100M□F	154.5	142.5	99.5	28	77	22	27	57.5	43	19	19	36	4.5	5	20	1/4"	10	40
200M□F	189	171	117	31.7	91	24	35	60	52	23	22	38	4.5	5	21	1/4"	10	42
300M□F	208	190	135	40	97	28	40	75	64	28	26	54	4.5	5	26	3/8"	13.5	53
400M□F	243	223	168.5	57	107	33	50	100	94	35	30.5	75	5.5	6	32	1/2"	15	68

Model\Item	A															
	1F	2F	3F	4F	5F	6F	7F	8F	9F	10F	11F	12F	13F	14F	15F	16F
100M□F	38	57	76	95	114	133	152	171	190	209	228	247	266	285	304	323
200M□F	44	67	90	113	136	159	182	205	228	251	274	297	320	343	366	389
300M□F	52	80	108	136	164	192	220	248	276	304	332	360	-	-	-	-
400M□F	61	96	131	166	201	236	271	306	-	-	-	-	-	-	-	-

Model\Item	KA															
	1F	2F	3F	4F	5F	6F	7F	8F	9F	10F	11F	12F	13F	14F	15F	16F
100M□F	28	47	66	85	104	123	142	161	180	199	218	237	256	275	294	313
200M□F	34	57	80	103	126	149	172	195	218	241	264	287	310	333	356	379
300M□F	42	70	98	126	154	182	210	238	266	294	322	350	-	-	-	-
400M□F	49	84	119	154	189	224	259	294	-	-	-	-	-	-	-	-