



The Name
for Safety.

The Book for Lifting Technology



บริษัท ไทแทน เซอร์วิส จำกัด

1/19 หมู่ 1 ต.พิมพา อ.บางปะกง จ.ฉะเชิงเทรา 24130 ประเทศไทย

TAX ID 0245554000604 Hotline 063-273-1222

Tel. : 038-989-373 ถึง 76 Fax. 038-989-377

Line : @titanservice Email: info.titanservice@gmail.com

www.titanservice.co.th Facebook.com/Titanservicecompany

Edition 3





Quality and the environment

Our principal objective consists of maximum customer satisfaction, the fulfilment of the high quality, environmental and safety requirements our products are subject to and the continuous, sustainable improvement of our processes. In line with these aims, THIELE introduced a quality management system in 1994 certified in accordance with ISO 9001, followed by an environmental management system certified in accordance with ISO 14001 in 2011. The energy management system is currently in the developmental stage, with ISO 50001 certification additionally planned for the beginning of 2013.

The long lifespan of our high quality products saves both on resources and the environment. This is why they have an excellent reputation among our international customers.

Customs

The increased globalization and the changed global security situation have caused the EU to introduce the status of an "Authorised Economic Operator" (AEO) as a form of effective risk management within the customs administrations.

The aim is to secure the continuous global supply chain from the manufacturer to the end-user. The company THIELE has furnished proof that it is a reliable trading partner and it has already been in possession of an AEO certificate since 19 October 2010.

All information given is based on our current knowledge and expertise and is supplied without obligations or commitments. This also applies to the patent rights of third parties. We do not give any obligatory warranty in the legal sense as to the properties of the products described in this publication. We expressly reserve the right to change our specifications in accordance with technical progress and company developments. This does not release the buyer from his obligation to inspect all incoming products. The quality of all our products is of course guaranteed in accordance with our general terms and conditions of sale.

The copyright for the published objects remains exclusively at the author of this document. Any duplication or utilization of such graphics or texts in other electronic or printed publications are not allowed without any agreement of the author.

A decorative border at the top of the page consisting of a chain of metal links.

Content

Page

1. Information	2
2. THIELE- TOP -Program	13
3. Lifting Products Grade 100	15
4. Lifting Products Grade 80	59
5. Lifting Points	111
6. Lashing Products	133
7. Hoist Chains	163
8. Hand Powered Cranes (TM-Series)	167
9. Rust & Acid Resistant Round Steel Chains	177
10. Fishing Chains	181
11. Conveyor Chains for Poultry Industry	183
12. Conveyor Chains and Lifting Products for Forestry and Farming	185
13. Inspection Service	189
14. Special Chains	191

i



The Company

Company

As a chain manufacturer with our drop forge, THIELE is one of the leading companies of the chain industry world-wide. Customers appreciate our excellent technical problem solving skills concerning conveying and lifting applications as well as our high quality and functionality standards. Our products and services are strictly based on the expectations and needs of our customers and thus ensure a high level of customer satisfaction. Our brand is firmly positioned in all global business regions which strengthen your competitive position as well.



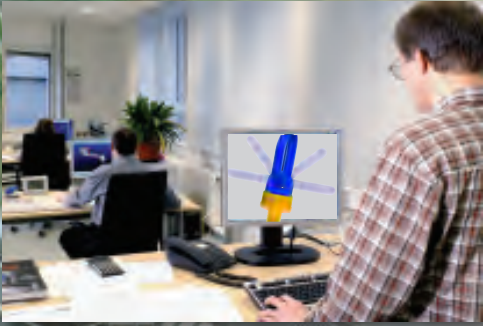

Development, CAD designs, chain dimensioning

The entire product development takes place in our own technical office. Modern 3D CAD programs support the designing of forged pieces and dies.

Precise volume calculations enable cost reductions to be implemented during the forging process. It is also possible to use 3D CAD programs to simulate complicated hoist chain processes on the chain wheel.



Production

THIELE offers a very wide product range with more than 3000 products. It is possible to make an individual tool selection as the forging takes place on our premises.

A consistent quality is ensured by the careful thermal treatment.



Service

A mobile testing service with qualified specialists inspects your chains on site.

Upon request, we are able to carry out extensive tests on chain slings, components, round steel and load suspension devices.



THIELE Drop Forging

Forgings weighting between 0.1 kg and 60 kg, and measuring up to 1000 mm, are produced on three forging hammers – 31.5 kJ, 40 kJ and 100 kJ (10 kJ is equivalent to an impact energy of 1 tonne from a 1 m height of drop) – and a 1600-tonne forging press. The feedstock comprises square billets with edge lengths of between 20 and 120 mm or round billets 18.5 to 60 mm in diameter.

The material is first cut to size by cropping or sawing before the individual segments are heated in an induction unit assigned to the respective forging machine. The heated blanks are then reshaped in a die by means of pneumatically generated impact energy or by a forming force applied via a centrifugal mass. Finally, the flash is removed from the finished piece. The forming process often involves working to extremely very fine tolerances.

After forging the components undergo careful heat treatment in order to fine-tune their final properties.

At THIELE we make all our dies and trimming and forging tools in-house. We also employ program-controlled machines that can produce shapes using the latest technology, including high-speed cutting.



Forging with quality assurance

i

An experienced workforce combined with reliable production methods are the key to real quality assurance.

All key product characteristics are continuously monitored in a series of elaborate routines that are carried out at THIELE's in-house testing and laboratory facilities. This includes comprehensive crack testing of all forged components.

Benefits:

- FEM-optimised hook design
- anatomical profile
- drop forged according to grain direction
- accurate machining
- large range of types and product options





General Information

Sales-Service

Our friendly Sales Team is available for you while the working hours and can be reached by the following phone-numbers.

Address:

Thiele GmbH & Co. KG
Werkstr. 3
DE-58640 Iserlohn
Germany

Working hours

Mo. – Th.: 8.00 – 16.30 h
Fr.: 8.00 – 16.00 h

Sales Director



Enrique Bermejo
Tel. +49 (23 71) 9 47-312
e.bermejo@thiele.de

Domestic

Sales North Germany



Günther Dreier
Tel. +49 (23 71) 9 47-232
g.dreier@thiele.de

Sales Middle of Germany



Patrick Jas
Tel. +49 (23 71) 9 47-321
p.jas@thiele.de

Sales East Germany (Field Service)



Klaus Drechsel
Tel. +49 (0) 160 96902365
k.drechsel@thiele.de

Sales South Germany



Manfred Blach
Tel. +49 (23 71) 9 47-225
m.blach@thiele.de

Domestic**Sales South East Germany (Field Service)****Helmut Gutjahr**

Tel. +49 (0) 171 7734213
h.gutjahr@thiele.de

Sales South West Germany (Field Service)**Fred Schremser**

Tel. +49 (0) 171 7624755
f.schremser@thiele.de

Inspection Service**Reiner Homrighausen**

Tel. +49 (23 71) 9 47-226
r.homrighausen@thiele.de

Sales Middle of Germany, Inspection Service**Alexandra Skop**

Tel. +49 (23 71) 9 47-317
a.skop@thiele.de

Sales West Germany (Field Service)**Jörg Risse**

Tel. +49 (171) 7639306
j.risse@thiele.de

Export**Sales Export Department****Diana Kühle**

Tel. +49 (23 71) 9 47-204
d.kuehle@thiele.de

Sales Export Department**Dominik Werth**

Tel. +49 (23 71) 9 47-222
d.werth@thiele.de

Sales Export Department**Heiko Kurz**

Tel. +49 (23 71) 9 47-223
h.kurz@thiele.de

Sales Export Department**Anika Meier**

Tel. +49 (23 71) 9 47-353
a.meier@thiele.de



Our seminar Program



For increased safety when handling sling and lashing chains

Our experienced instructors train your employees as specialists and experts in sling technology and provide well-founded knowledge on the handling and use of sling and lashing chains. We provide the following seminars:

1-day seminar (Training as a specialist for sling technology)

The seminar comprises:

- ▶ Chain and sling device studies
- ▶ Product instructions and instructions for use
- ▶ Wear behaviour and discard criteria for sling chains
- ▶ Material tests and metal studies concerning round link chains
- ▶ Sling components
- ▶ Technical properties of round steel chains and sling components
- ▶ Insight into the relevant standards
- ▶ Documentation and bibliography
- ▶ Participation certificate

2-day seminar (Training as an expert for sling technology)

In this seminar, the participants familiarise themselves with the respective sling technology standards and are provided with extensive insights into the testing of chains and their handling. After successful completion, the participants are qualified to test the sling technology in their company.

The training comprises the following in addition to the contents of the 1-day seminar:

- ▶ Instruction on Chapter 2.8 of BGR 500 (German occupational health insurance regulations)
- ▶ Instruction on EN 818, EN 1677, DIN 5692, DIN 3688-3
- ▶ Instruction on Machinery Directive 2006/42/EC
- ▶ Product training
- ▶ Application examples
- ▶ Practical exercises
- ▶ Chain inspection
- ▶ Tour of a company
- ▶ Documentation and bibliography
- ▶ Participation certificate

Benefit from our 75 years of experience and ask us when the next seminar dates are.

We would be pleased to send you detailed written information.

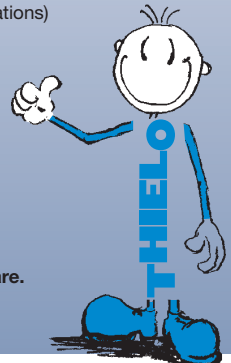



The THIELE Book for Lifting Technology is also available on CD-ROM.

i

The catalogue includes user information, geometry data and is a perfect support for your construction department.

3D-CAD data for Lifting Points Program included!

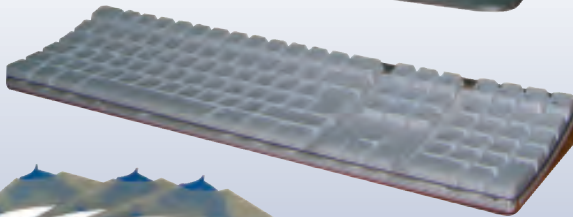

Please ask for our CD:
lifting-technology@thiele.de

Further information also available under: www.thiele.de



THIELE Chain Configurator



The **THIELE Sling Chain configurator and calculator** at the customer portal on our website simplify you considerably the offer configuration of Sling Chains.

You save time, eliminate error sources at the assignment of components, the addition of the part lengths and the summation of weights and costs.

Just upload your company data and your logo. Set up your customized offer under consideration of having regard to all commercial and technical aspects.

You get a structured offer with a detailed specification.

Please ask for your login data.

SERVICE at THIELE receives our utmost importance!



The THIELE TOP Program

A branch novelty: the **THIELE-TOP Program** is **ALWAYS** available.

This puts an end to the customers having to pay storage costs!

The classic "fast moving consumer goods" in the **TOP Program** are perfect for quick business.

You can benefit from the top class service for just 8% more than you are currently paying under the agreed conditions net of a freight rate of **EUR 25.00** per delivery.

We can only offer this service if we restrict the size of your orders to the max. quantities listed below. A combination with other products is unfortunately not possible.

TWN	Artikel-No.	Article Description	Trade Size	Packaging Unit	max. order quantity
Grade 80					
0805	F01465	Round Steel Link Chain 8 x 24 mm	8-8 (5/16-8)	100 m	300 m = 3 PU*
0805	F01470	Round Steel Link Chain 10 x 30 mm	10-8 (3/8-8)	100 m	300 m = 3 PU*
0805	F01475	Round Steel Link Chain 13 x 39 mm	13-8 (1/2-8)	100 m	300 m = 3 PU*
0829	F30810	THI-LOK® connector	8-8 (5/16-8)	8 pcs.	24 pcs. = 3 PU*
0829	F30820	THI-LOK® connector	10-8 (3/8-8)	14 pcs.	42 pcs. = 3 PU*
0829	F30830	THI-LOK® connector	13-8 (1/2-8)	8 pcs.	24 pcs. = 4 PU*
* PU = Packaging Unit					

The new THIELE TOP products which are available are easy to recognise both in the 2012 Hoist Chains catalogue and in all future campaign flyers:

All of the products with **blue article numbers** will be delivered the next day throughout Germany as long as we receive the order before 11.00 a.m..

This delivery period can obviously not be adhered to during weeks in which there is a bank holiday and at the turn of the year.

The TOP range is just another proof of our logistics competence with the plant cooperation logistics concept, the order status tracking in real time via login.

Avail yourself of this special service with the new eco-packaging for round steel chains including a **notification of sale** which is unique in the branch.

This offer is only valid for Germany.

In case of orders from the Europe, we only commit us to supply the goods from THIELE the same day.

The freight cost and ETA for orders from abroad, are subject to be additionally negotiated from case to case.





Our Brands



Grade 100



Grade 80



Lifting Points



Hoist Chains



Hand Powered Cranes

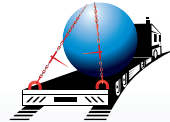

Lashing Products



Rust & Acid Resistant
Round Steel Chains



Fishing Chains



Conveyor Chains for
Poultry Industry



Conveyor Chains and Lifting
Products for Forestry & Farming



Inspection Service



Special Chains



THIELE

App



THIELE









XL

Lifting Products Grade 100



Product Overview **XL**

<p>TWN 1805</p> 	<p>TWN 0072</p> 
<p>Page 28 – 29</p> <p>Round Steel Link Chains XL</p>	





<p>TWN 1807</p> 	<p>TWN 1808</p> 	<p>TWN 1809</p> 	<p>TWN 1795</p> 	<p>TWN 1810/1</p> 
<p>TWN 1810/2</p> 	<p>TWN 1810/4</p> 			
<p>Page 30 – 33</p> <p>Suspension Components XL</p>				

<p>TWN 1829</p> 	
<p>Page 34</p> <p>Connector XL-LOK®</p>	



<p>TWN 1836</p> 	<p>TWN 1837</p> 	<p>TWN 1838</p> 	<p>TWN 1840/1</p> 	<p>TWN 1841/1</p> 
<p>Page 35 – 38</p> <p>Hooks XL</p>				



Product Overview **XL**

<p>Page 38 – 41</p>	<p>TWN 1827/1</p> 	<p>TWN 1851</p> 	<p>TWN 1852</p> 	<p>TWN 1896</p> 	<p>XL</p>
<p style="text-align: center;">Shortening Components XL</p>					

<p>Page 41</p>	<p>TWN 1871</p> 	
<p style="text-align: center;">Shackles XL</p>		

<p>Page 42 – 43</p>	<p>TWN 1454</p> 	<p>TWN 1455</p> 	
<p style="text-align: center;">Chain Tensioners XL</p>			





Product Overview **XL**

TWN 1812



Page
44

Special Sling Component **XL**

TWN 1410



TWN 1411



Page
44 – 45

Lashing Chains **XL**

TWN 0944



TWN 0945



TWN 1402



TWN 1904/0



TWN 1908/0



TWN 1929/0



TWN 1930/0



TWN 1931/0



TWN 1933/0



TWN 1935



TWN 1940



TWN 1946



Page
45 – 50

Spare Parts and Accessories **XL**



Product Overview **XL**

TWN 1601/ 1-Leg



TWN 1651/2-Leg



TWN 1751/4-Leg



XL

Page
51 – 55

Chain Slings **XL**

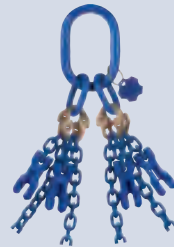

Page
56

Shortening Options **XL**

Form K11



Form K12



Form K22



Page
57

Endless Chains **XL**



Lifting Products Grade 100

Comparison between Grade 80 and Grade 100

Save up to 30% weight on a 2-leg chain sling.

for Example:



Article	THIELE Plant Standard	Pieces
Master Link	TWN 1831	1
XL-LOK®	TWN 1829	2
2 m Round Steel Link Chain	TWN 1805	2
Clevis Sling Hook	TWN 1840/1	2

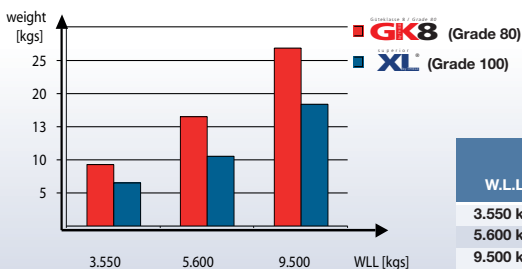

W.L.L.	GK8 Weight	XL Weight	Saving
3.550 kg	9,3 kg	6,6 kg	30 %
5.600 kg	16,5 kg	10,6 kg	35 %
9.500 kg	26,8 kg	18,4 kg	31 %

Properties	GK8	XL
Working Load Limit (WLL)		25 % stronger
Safety Factor	4	4 (-7 %)
Elongation at break (completed finish)	20 %	20 %
Weight		abt. 30 % less
Nominal Size		same as GK8
Breaking Stress	800 N/mm ²	1000 N/mm ²
Component Strength	1150-1250 MPa	1450-1550 MPa
Load Factor	acc. to catalogue	same as GK8
Temperature Application Range	-40 – 200 °C 200 – 300 °C (90 %) 300 – 400 °C (75 %)	XL200 -20 – 200 °C (100 %) XL400 -30 – 200 °C (100 %) 200 – 300 °C (90 %) 300 – 380 °C (60 %)
Asymmetry Factor	acc. to catalogue	same as GK8
Acids and Lyes	not allowed	not allowed
Compatibility with other system	possible	restricted
Colour Round Steel Link Chains (solvent-free)	black painted (RAL 9005)	Ultramarine blue painted (RAL 5002)
Colour Forgings (solvent-free)	powder painted red (RAL 3003)	Ultramarine blue powder painted (RAL 5002)
Standards	European and International	PAS 1061 (Manufactures Recommendation)
Wear		less abrasion



Selection Criteria for **XL**-Slings Chains

1. Determine the **weight of the load** to be lifted.
2. Check **number of chain-legs** required
(depending on the numbers of available lifting points).
3. Determine the **nominal size** of the chain sling by taking the **inclination angle** into consideration.
(See table 1-3 in page 25-27.)
4. Consider possible existing **temperature influences**. (See special advices page 26)
5. Consider that **asymmetry** may influence the load factor. (See table 4 page 27)
6. Choose the master links, shortening elements and components suitable for the selected chain size.
7. Determine the **chain length** by considering the total-effective-reach.
8. Inspect selected components and/or chain slings in-use to ensure that they meet or exceed all applicable industry and government safety rules and regulations.

XL





Chain inspection gauge XL



Inspection of Material Diameter

Material diameter (min.)

Front Side



Pitch inspection

Trade Size

Inspection of permanent elongation



Inspection of permanent elongation

Back Side



We only supply the **XL**-Chain Sling Gauge with marking details according to EN 818-4 as a spare part.

XL-Identification Tag

The details of the Identification Tag are in accordance with EN 818-4 for chain slings.
The Grade **XL** differs particularly by shape (decagon) and colour (RAL 5002) in comparison to other Grades.

Front Side



XL

Back Side

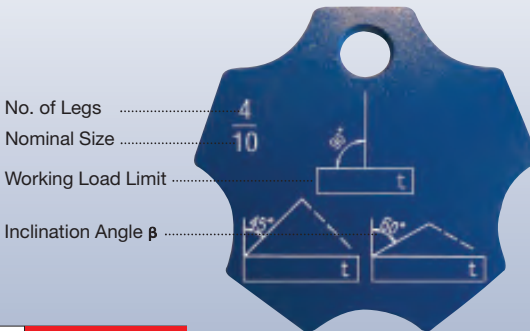

Legal marking of Grade 80 chains by the German professional association

The number 4 under the H only represent a registration number of the German professional association and helps in care of damage to find the manufacture of the chain. The marking is also recognized from all international certification societies as well as from work authorities etc. among others A. I. B. Brüssel.



Liability, Assembly, Material



Round Steel Link Chains and Components **XL**-400 are stamped with H4, Nominal Size and Grade **XL** and a traceability code.



Round Steel Link Chains **XL** -200 are stamped with T 3, Nominal Size and Grade **10** and a traceability code. They are only allowed to couple with original **XL**-Components of the corresponding Trade Size.

Liability

THIELE does not take any type of liability for **XL**-Round Steel Link Chains and Components which are used together with other manufacturers products.

Assembly

The combination of different Grades in one sling chain is not allowed.



Use only original **XL**-Spare Parts.

Material

For the production of Grade **XL**, only High Alloy Steels according to DIN 17115 are used.

THIELE Plant Standard (TWN)

THIELE Plant Standard fulfill the requirements of the EG Directive for Machines, particularly for the safety relevant components. The Working Load Limits and the test requirements are **SUPERIOR** to European Standards.

Working Load Limit Tables XL

Working Load Limit in t – direct sling

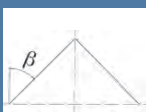
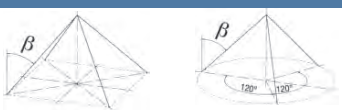
Table 1		1-leg		2-leg		3- and 4-leg	
							
Inclination Angle		$\beta = 0^\circ$		$0^\circ < \beta \leq 45^\circ$	$45^\circ < \beta \leq 60^\circ$	$0^\circ < \beta \leq 45^\circ$	$45^\circ < \beta \leq 60^\circ$
Load Factor		1		1,4	1	2,1	1,5
Trade Size	Nominal Size [mm]						
6-XL	6	1,40	2,00	1,40		3,00	2,12
8-XL	8	2,50	3,55	2,50		5,30	3,75
10-XL	10	4,00	5,60	4,00		8,00	6,00
13-XL	13	6,70	9,00	6,70		14,00	10,00
16-XL	16	10,00	14,00	10,00		21,20	15,00
20-XL	20	16,00	22,40	16,00		33,50	23,60
22-XL	22	19,00	26,50	19,00		40,00	28,00
26-XL	26	26,50	37,50	26,50		56,00	40,00

XL

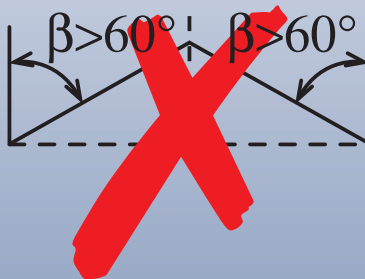

Additional nominal sizes are also available in welded finish on request.

Inclination Angle $\beta > 60^\circ$



Can fail if damaged, misused or overloaded. Inspect before use. Use only if trained. Observe rated capacity in table 1, 2, 3. DEATH or INJURY can occur from improper use or maintenance.

Working Load Limit in t – choke hitch

Table 2		1-leg	2-leg	3- and 4-leg
				
Inclination Angle β		$\beta = 0^\circ$	$0^\circ < \beta \leq 45^\circ$	$45^\circ < \beta \leq 60^\circ$
Load Factor		0,8	1,12	0,8
Trade Size	Nominal Size [mm]			
6-XL	6	1,12	1,60	1,12
8-XL	8	2,00	2,80	2,00
10-XL	10	3,15	4,50	3,15
13-XL	13	5,30	7,50	5,30
16-XL	16	8,00	11,20	8,00
20-XL	20	12,80	17,90	12,80
22-XL	22	15,20	21,20	15,20
26-XL	26	21,20	29,60	21,20

Inclination angles β over 60° are prohibited. Additional nominal sizes are also available in welded finish on request.

Temperature Application Range

Round Steel Link Chains XL-200



Temperature Application Range	W.L.L.
-20°C to 200°C	100 %

Round Steel Link Chains XL-400 (according to PAS 1061)

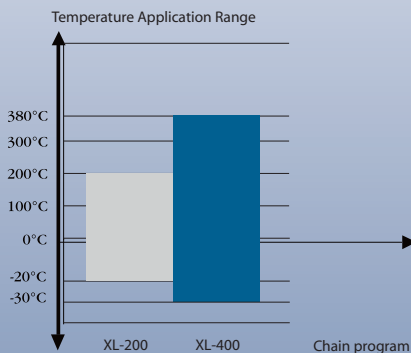
Temperature Application Range	W.L.L.
-30°C to 200°C	100 %
over 200°C to 300°C	90 %
over 300°C to 380°C	60 %

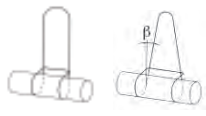
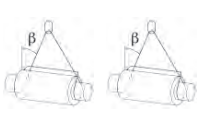

Working Load Limit in t – endless chain

Table 3		K11		K12	K13	K22	K23
							
Inclination Angle β		$\beta = 0^\circ$	$0^\circ < \beta \leq 25^\circ$	$0^\circ < \beta \leq 45^\circ$	$45^\circ < \beta \leq 60^\circ$	$0^\circ < \beta \leq 45^\circ$	$45^\circ < \beta \leq 60^\circ$
Load Factor		1,6	1,45	1,12	0,8	1,7	1,2
Trade Size	Nominal Size [mm]						
6-XL	6	2,24	2,00	1,50	1,12	2,36	1,60
8-XL	8	4,00	3,55	2,80	2,00	4,00	3,00
10-XL	10	6,30	5,66	4,50	3,15	6,70	4,75
13-XL	13	10,60	9,50	7,50	5,30	11,20	8,00
16-XL	16	16,00	14,00	11,20	8,00	16,00	11,80
20-XL	20	25,00	22,40	18,00	12,50	26,50	19,00
22-XL	22	30,00	26,50	21,20	15,00	31,50	22,40
26-XL	26	40,00	37,50	28,00	21,20	42,50	31,50

XL

Inclination angles β over 60° are prohibited. Additional nominal sizes are also available in welded finish on request.

Table 4 Load Factor at Asymmetry

No. of Legs	1	2		3		4	
Inclination Angle β	-	$0^\circ - 45^\circ$	$46^\circ - 60^\circ$	$0^\circ - 45^\circ$	$46^\circ - 60^\circ$	$0^\circ - 45^\circ$	$46^\circ - 60^\circ$
Load factor	1	1	1	1,4	1	1,4	1

Form K11



Form K12



Form K22



Can fail if damaged, misused or overloaded. Inspect before use. Use only if trained. Observe rated capacity in table 1, 2, 3. DEATH or INJURY can occur from improper use or maintenance.



Product Features **XL**

Round Steel Link Chains TWN 1805 acc. to PAS 1061 **XL-400**



Trade Size	6-XL	8-XL	10-XL	13-XL	16-XL	20-XL	22-XL	26-XL
Art.No.	F01610B	F01615B	F01622B	F01629B	F01635B	F01638B	F01650B	F01660B
Nominal Size (d)	6	8	10	13	16	20	22	26
Pitch (p)	18	24	30	39	48	60	66	78
Pitch Tolerance (±)	0,5	0,7	0,9	1,2	1,4	1,8	2,0	2,3
Inside Width w _i min.	7,8	10,92	13,0	17,48	20,8	26,0	28,6	33,8
Outside Width w _e max.	22,2	29,6	37,0	48,1	59,2	74,0	81,4	96,2
Working Load Limit (t)	1,4	2,5	4,0	6,7	10,0	16,0	19,0	26,5
Weight approx (kg/m)	0,9	1,6	2,5	4,3	6,5	10,1	12,3	17,1

dipped in environmental friendly AQUA-chain lacquer

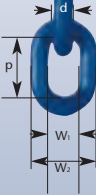



Round Steel Link Chains TWN 0072 acc. to ASTM 973 **XL-200**

New

Trade Size	6-10	7-10	8-10	10-10	13-10	16-10	
Art.No.	F01616	F01621	F01617	F01618	F01619	F01620	
Nominal Size (d)	6	7	8	10	13	16	
Pitch (p)	18	22	24	30	39	48	
Pitch Tolerance (±)	0,5	0,7	0,7	0,9	1,2	1,4	
Inside Width w_1 min.	7,95	9,53	10,92	13,0	17,48	20,63	
Outside Width w_2 max.	22,2	25,9	29,6	37,0	48,1	59,2	
Working Load Limit (t)	1,4	1,95	2,6	4,0	6,8	10,3	
Weight approx (kg/m)	0,9	0,9	1,6	2,5	4,1	6,2	

XL



dipped in environmental friendly AQUA-chain lacquer

Comparison between Round Steel Link Chains XL-200 and XL-400

Grade	XL-200	XL-400
Standard	ASTM 973	PAS 1061
Material	alloyed steel	higher alloyed steel
Temperature Application Range	-20°C up to 200°C	-30°C up to 380°C; reduction starting from 200°C
Working Load Limit (WLL)	25% higher than Grade 80	25% higher than Grade 80
Manufacturers Proof Force	min. 2 x WLL	min. 2,5 x WLL
Elongation at break (completed finish)	min. 20%	min. 20%
Breaking Force	min. 4 x WLL	min. 4 x WLL; up to 7% reduction allowed
Charpy Notch Value	min. 36 J at - 20°C	min. 42 J at - 20°C or at lower temperatures mentioned by the manufactures
Deflection	min. 0,8 x d	min. 0,8 x d
Fatigue		min. 20.000 LW
Material properties (stress corrosion)		according to standard
Finish	Galvanizing not allowed	Galvanizing not allowed
Colour (solvent-free)	RAL 7011	RAL 5002
Marking	XL200	XL400
Certification	T3 - (trade size) -10 Own approval	H4/T3 - (trade size) -XL approved by BG

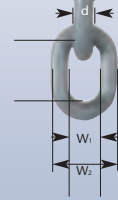

Suspension Components **XL**

New

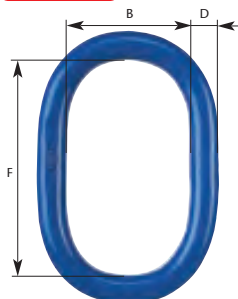

The **Master Link Form A TWN 1807**

according to DIN 5688 for 1-leg chain slings enables an easy assembly of a **XL-LOK**[®] TWN 1829. This way of coupling offers a higher flexibility in assembling of chain slings with the advantage of less stock inventory.

The Master Link Form A TWN 1807 is suitable for Crane Hooks according to DIN 15401:

Trade Size Crane Hook No.

6 - XL	No. 2,5
8 - XL	No. 2,5
10 - XL	No. 5
13 - XL	No. 6
16 - XL	No. 8

Finish: RAL 5002

Trade Size	Article-No.	Nominal Size [mm]	Working Load Limit [t max]	Dimensions [mm]			Weight approx. [kgs]
				D	F	B	
6-XL	F180706	6	1,40	13	90	50	0,29
8-XL	F180708	8	2,50	16	110	60	0,53
10-XL	F180710	10	4,00	18	130	70	0,79
13-XL	F180713	13	6,70	22	160	90	1,50
16-XL	F180716	16	10,00	26	180	100	2,30

New

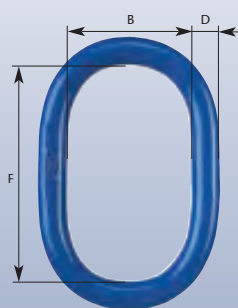

The **Master Link Form A TWN 1808**

according to DIN 5688 for 2-leg chain slings enables an easy assembly of a **XL-LOK**[®] TWN 1829. This way of coupling offers a higher flexibility in assembling of chain slings with the advantage of less stock inventory.

The Master Link Form A TWN 1808 is suitable for Crane Hooks according to DIN 15401:

Trade Size Crane Hook No.

6 - XL	No. 2,5
8 - XL	No. 5
10 - XL	No. 6
13 - XL	No. 8
16 - XL	No. 10

Finish: RAL 5002

Trade Size	Article-No.	Nominal Size [mm]	Working Load Limit [t max]	Dimensions [mm]			Weight approx. [kgs]
				D	F	B	
6-XL	F180806	6	2,00	13	90	50	0,29
8-XL	F180808	8	3,55	18	130	70	0,79
10-XL	F180810	10	5,60	20	140	80	1,10
13-XL	F180813	13	9,00	26	180	100	2,30
16-XL	F180816	16	14,00	32	230	125	4,40



Suspension Components XL

The **Master Link Assembly TWN1809** according to DIN 5688 for 3-/ 4-leg chain slings enables easy assembling of a **XL-LOK®** TWN1829.

The Master Link Assembly TWN 1809 is suitable for Crane Hooks according to DIN 15401:

Trade Size	Crane Hook No.
6 - XL	No. 5
8 - XL	No. 6
10 - XL	No. 8
13 - XL	No. 10
16 - XL	No. 16

Finish: RAL 5002

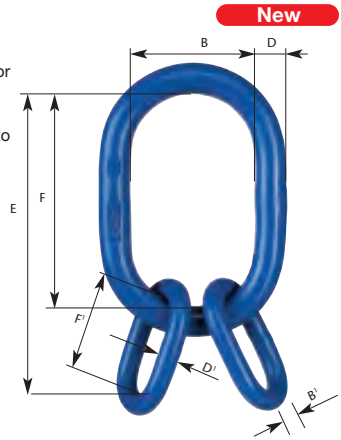

XL

Trade Size	Article-No.	Nominal Size [mm]	W. L. L. 0° < β ≤ 45° [t max]	Dimensions [mm]							Weight approx. [kgs]
				E	D	F	B	D'	F'	B'	
6-XL	F180906	6	3,00	170	16	110	60	13	60	30	1,00
8-XL	F180908	8	5,30	210	20	140	80	16	70	35	2,20
10-XL	F180910	10	8,00	270	26	180	100	20	90	45	3,80
13-XL	F180913	13	14,00	350	32	230	125	26	120	60	7,70
16-XL	F180916	16	21,20	420	40	290	160	28	130	65	13,00

The Intermediate Master Link Type B TWN 1795

according to DIN 5688-3:2007-04 enables assembling of a XL-Lok and other components. The WLL as well as the manufacturers and proof requirements are based on the standard DIN EN 1677-01:2009 and DIN EN 1677-4:2009-3 considering a 25% higher WLL.

Finish: RAL 5002

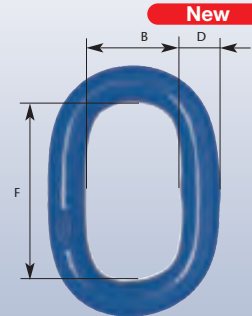

Trade Size	Article-No.	Working Load Limit [t max]	Dimensions [mm] D F B	Weight approx. [kgs]	Manufacturing Proof Load [MPF] [kN]	Break Force (BF) [kN]
B8	F179508	1,40	8 36 18	0,05	34,30	54,90
B10	F179510	2,50	10 46 23	0,09	61,30	98,10
B13	F179513	4,00	13 60 30	0,20	98,10	157,00
B16	F179516	6,70	16 70 35	0,36	164,00	263,00
B20	F179520	10,00	20 90 45	0,73	245,00	392,00
B22	F179522	12,50	22 100 50	0,97	306,00	490,00
B26	F179526	16,00	26 120 60	1,60	392,00	628,00
B28	F179528	19,00	28 130 65	1,90	466,00	745,00
B32	F179532	26,50	32 140 70	2,90	650,00	1040,00
B36	F179536	31,30	36 160 80	4,20	766,00	1226,00
B40	F179540	40,00	40 180 90	5,80	981,00	1569,00
B45	F179545	50,00	45 200 100	8,20	1230,00	1960,00

Suspension Components XL

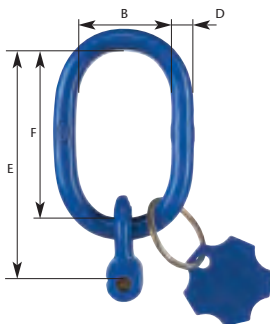

The Fixed Size Master Link Assembly TWN 1810/1

Type TAA1 for 1- leg chain slings is automatically determined to the nominal size by the Ringshackle. The Ringshackle moves freely. A welded identification tag contains all the necessary data required. The dimensions are in accordance with DIN 5688, form A. The Fixed Size Master Link Assembly Type TAA 1 can also be delivered without the Ringshackle as a Master Link TWN 1807.

The Fixed Size Master Link Assembly TWN 1810/1 is suitable for Crane Hooks according to DIN 15401:

Trade Size	Crane Hook No.
6 - XL	No. 2,5
8 - XL	No. 2,5
10 - XL	No. 5
13 - XL	No. 6
16 - XL	No. 8

Finish: RAL 5002

Trade Size	Article-No.	Nominal Size [mm]	Working Load Limit [t max]	Dimensions [mm]				Weight approx. [kgs]
				E	D	F	B	
6-XL	F1810106	6	1,40	121	13	90	50	0,40
8-XL	F1810108	8	2,50	147	16	110	60	0,71
10-XL	F1810110	10	4,00	176	18	130	70	1,21
13-XL	F1810113	13	6,70	219	22	160	90	2,33
16-XL	F1810116	16	10,00	256	26	180	100	3,90

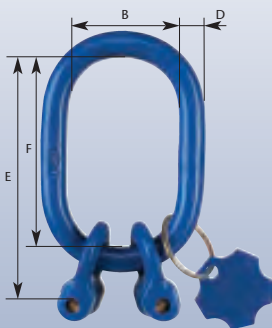

The Fixed Size Master Link Assembly TWN 1810/2

Type TAA2 for 2- leg chain slings is automatically determined to the nominal size by the Ringshackle. The Ringshackle moves freely. A welded identification tag contains all the necessary data required. The dimensions are in accordance with DIN 5688, form A. The Fixed Size Master Link Assembly Type TAA2 can also be delivered without the Ringshackle as a Master Link TWN 1808.

The Fixed Size Master Link Assembly TWN 1810/2 is suitable for Crane Hooks according to DIN 15401:

Trade Size	Crane Hook No.
6 - XL	No. 2,5
8 - XL	No. 5
10 - XL	No. 6
13 - XL	No. 8
16 - XL	No. 10

Finish: RAL 5002

Trade Size	Article-No.	Nominal Size [mm]	W. L. L. $0^\circ < \beta \leq 45^\circ$ [t max]	Dimensions [mm]				Weight approx. [kgs]
				E	D	F	B	
6-XL	F1810206	6	2,00	121	13	90	50	0,50
8-XL	F1810208	8	3,55	167	18	130	70	1,20
10-XL	F1810210	10	5,60	186	20	140	80	1,90
13-XL	F1810213	13	9,00	239	26	180	100	4,00
16-XL	F1810216	16	14,00	296	32	230	125	7,60



Suspension Components XL

The Fixed Size Master Link Assembly TWN 1810/4

Type TAA4 for 3/4- leg chain slings is automatically determined to the nominal size by the Ringshackle. The Ringshackle moves freely. A welded identification tag contains all the necessary data required. The dimensions are in accordance with DIN 5688, form A. The Fixed Size Master Link Assembly Type TAA4 can also be delivered without the Ringshackle as a Master Link TWN 1809.

The Fixed Size Master Link Assembly TWN 1810/4 is suitable for Crane Hooks according to DIN 15401:

Trade Size	Crane Hook No.
6 - XL	No. 5
8 - XL	No. 6
10 - XL	No. 8
13 - XL	No. 10
16 - XL	No. 16

Finish: RAL 5002

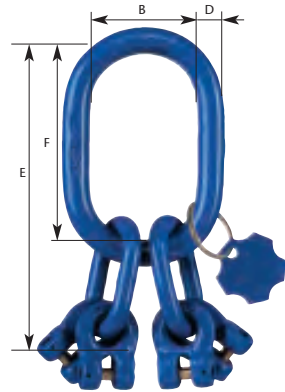

XL

Trade Size	Article-No.	Nominal Size [mm]	W. L. L. $0^\circ < \beta \leq 45^\circ$ [t max]	Dimensions [mm]					Weight approx. [kgs]
				E	D	F	B	D ¹	
6-XL	F1810406	6	3,00	201	16	110	60	13	1,40
8-XL	F1810408	8	5,30	247	20	140	80	16	2,70
10-XL	F1810410	10	8,00	316	26	180	100	20	5,40
13-XL	F1810413	13	14,00	409	32	230	125	26	11,20
16-XL	F1810416	16	21,20	495	40	290	160	28	19,40





Connector **XL-LOK**®

New

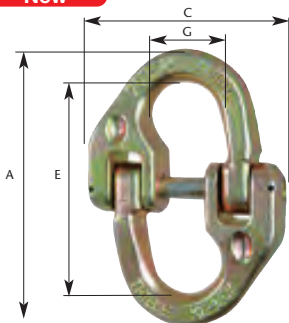

The Connector **XL-LOK**® TWN 1829

consists of two lok halves, which enables the assembly of Round Steel Link Chains, or various components and lifting points to each other. The lok halves are interchangeable. The assembly do not requires the expensive bush.

The assembly will be completed with two locking spirol pins according to the assembling instruction as shown below.

The shape makes the Original of THIELE unique.

100% Magnetic Crack Tested. BG - approved.

Finish: electro galvanized and yellow chromated

Lift it in »Style«

Trade Size	Article-No.	Nominal Size [mm]	Working Load Limit [t max]	Dimensions [mm]				Weight approx. [kgs]
				E	G	A	C	
6-XL	F30801	6	1,40	45	14	60	51	0,10
8-XL	F30811	8	2,50	60	18	80	63	0,27
10-XL	F30821	10	4,00	75	22	100	76	0,45
13-XL	F30831	13	6,70	98	28	131	93	1,00
16-XL	F30841	16	10,00	110	33	151	114	1,38

XL-LOK® Assembly instruction

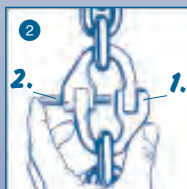
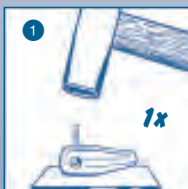



Hooks XL

The **Eye Self Locking Hook TWN 1836** automatically locks at load. The flattened extra large eye offers universal coupling options. A robust trigger at the back side of the hook can be easily hand operated. Despite of an extra wide hook opening the Eye Self Locking Hooks offer a slim shape and enable an versatile use. 100% Magnetic Crack Tested.

The available Trigger Sets are universal for hooks type TWN1836, 1837 and 1838.

100% Magnetic Crack Tested. BG - approved.

Finish: RAL 5002

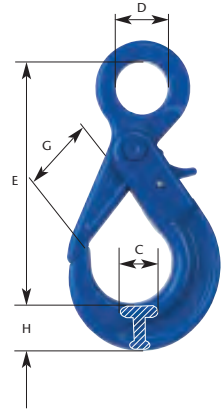

XL

Trade Size	Article-No.	Nominal Size [mm]	Working Load Limit [t max]	Dimensions [mm]					Weight approx. [kgs]
				E	D	G	H	C	
6-XL	F09220	6	1,40	110	22	34	24	15	0,50
8-XL	F09221	8	2,50	134	30	46	26	18	0,80
10-XL	F09222	10	4,00	167	36	56	33	25	1,55
13-XL	F09223	13	6,70	200	47	72	42	34	3,15
16-XL	F09224	16	10,00	253	60	88	47	35	6,05

The **Clevis Self Locking Hook TWN 1837** automatically locks at load. A robust trigger at the back side of the hook can be easily hand operated. Despite of an extra wide hook opening the Clevis Self Locking Hooks offer a slim shape and enable an versatile use. 100% Magnetic Crack Tested.

The available Trigger Sets are universal for hooks type TWN1836, 1837 and 1838.

100% Magnetic Crack Tested. BG - approved.

Finish: RAL 5002

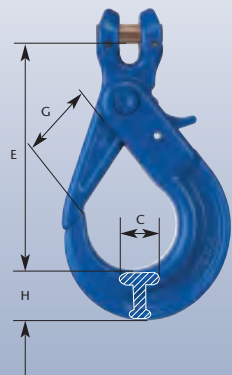

Trade Size	Article-No.	Nominal Size [mm]	Working Load Limit [t max]	Dimensions [mm]				Weight ca. [kgs]
				E	G	H	C	
6-XL	F09200	6	1,40	88	34	24	15	0,50
8-XL	F09201	8	2,50	111	46	26	18	0,75
10-XL	F09202	10	4,00	142	56	33	25	1,50
13-XL	F09203	13	6,70	175	72	42	34	3,10
16-XL	F09204	16	10,00	214	88	47	35	5,90



Hooks XL

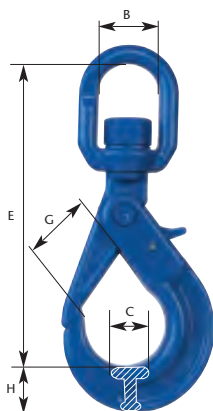

The **Swivel Self Locking Hook TWN 1838** automatically locks at load. A fine machined cone and brass gliding bushing make the hook light turnable. The lateral flattening in the swivel offer additional coupling options. A robust trigger at the back side of the hook can be easily hand operated.

Despite of an extra wide hook opening the Swivel Self Locking Hooks offer a slim shape and enable an versatile use.

The available Trigger Sets are universal for hooks type TWN1836, 1837 and 1838.

100% Magnetic Crack Tested. BG-approved.

Finish: RAL 5002

Trade Size	Article-No.	Nominal Size [mm]	Working Load Limit [t max]	Dimensions [mm]					Weight approx. [kgs]
				E	G	H	C	B	
6-XL	F09240	6	1,40	144	34	24	10	30	0,60
8-XL	F09241	8	2,50	178	45	27	12	38	1,00
10-XL	F09242	10	4,00	208	55	33	14	44	2,00
13-XL	F09243	13	6,70	252	68	44	18	50	3,80
16-XL	F09244	16	10,00	322	85	46	20	66	7,00



Hooks XL

The **Clevis Sling Hook TWN1840/1** with its robust forged Safety Latch and its clevis is designed to the corresponding nominal size. The onforged measurement points and maximum admissible values allows an easy check of the hook opening. The Safety Latch is protected by a wear edge of the hook body. Additionally the safety latch has a fixed position due to the forged seat at the tip of the hook.

The shape makes the Original of THIELE unique.

100% Magnetic Crack Tested. BG-approved.

Finish: RAL 5002

New

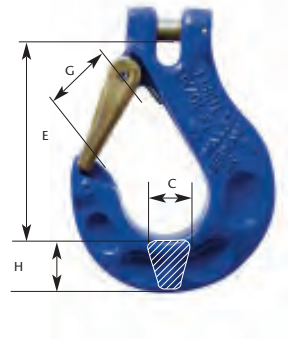

XL

Lift it in »Style«

Trade Size	Article-No.	Nominal Size [mm]	Working Load Limit [t max]	Dimensions [mm]				Weight approx. [kgs]
				E	G	H	C	
6-XL	F336050	6	1,40	75	24	20	17	0,36
8-XL	F336150	8	2,50	92	30	25	22	0,75
10-XL	F336250	10	4,00	113	37	32	28	1,40
13-XL	F336350	13	6,70	133	42	41	35	2,50
16-XL	F336450	16	10,00	162	51	50	41	4,40



Hooks XL

New

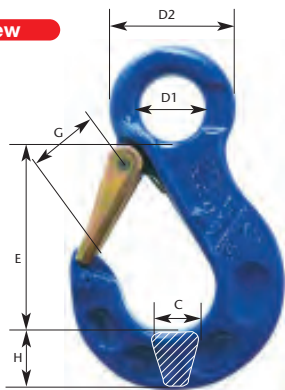

The **Eye Sling Hook TWN1841/1** with its robust forged Safety Latch and its eye is designed to the corresponding nominal size.

The onforged measurement points and maximum admissible values allows an easy check of the hook opening. The Safety Latch is protected by a wear edge of the hook body. Additionally the safety latch has a fixed position due to the forged seat at the tip of the hook. The shape makes the Original of THIELE unique.

100% Magnetic Crack Tested. BG-approved.

Finish: RAL 5002

Lift it in »Style«

Trade Size	Article-No.	Working Load Limit [t max]	Dimensions [mm]						Weight approx. [kgs]
			E	D1	D2	G	H	C	
6-XL	F32905	1,40	91	11	21	24	20	17	0,36
8-XL	F32915	2,50	118	14	28	30	25	22	0,78
10-XL	F32925	4,00	145	18	36	37	32	28	1,50
13-XL	F32935	6,70	168	21	42	42	41	35	2,55
16-XL	F32945	10,00	210	27	54	51	50	41	4,65

New

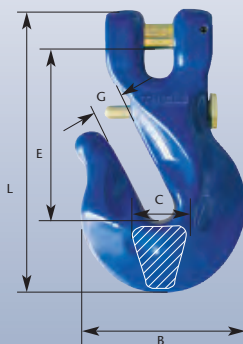

The **Shortening Hook TWN1827/1** according to DIN 5692 makes the lifting of loads safer. The new shape of the shortening Hooks TWN 1827/1 offer you much more safety than with conventional shortening hooks. The extra wide chain attachment enables us to guarantee you an especially firm seating of the inserted chain link and it is also protected from damage at the same time. The locking pin prevents an accidental loosening of the sling chain.

With our new TWN 1827/1 shortening hook, we are offering you grade 10 perfection together with a long shelf life of your slinging equipment.

100% Magnetic Crack Tested. BG-approved.

Finish: RAL 5002

Lift it in »Style«

Trade Size	Article-No.	Nominal Size [mm]	Working Load Limit [t max]	Dimensions [mm]					Weight approx. [kgs]
				E	G	L	B		
6-XL*	F33195	6	1,40	-	-	-	-	-	-
8-XL*	F33205	8	2,50	58	9,5	100	60	34	0,49
10-XL*	F33215	10	4,00	72	12	124	75	42	0,95
13-XL*	F33225	13	6,70	93	15	158	95	54	1,86
16-XL*	F33235	16	10,00	-	-	-	-	-	-

*In development



Shortening Components XL

The Clevis Shortening Claw TWN 1851

proven over many decades, has been further developed into the Grade **XL** and its clevis is designed to the corresponding nominal size. The chain has a safe seat in the claw pocket so that premature release will be avoided at any time.

100% Magnetic Crack Tested. BG-approved.

Finish: RAL 5002

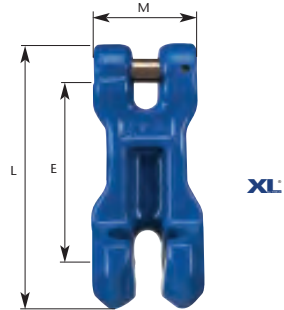

Trade Size	Article-No.	Nominal Size [mm]	Working Load Limit [t max]	Dimensions [mm]			Weight approx. [kgs]
				E	L	M	
6-XL	F34904	6	1,40	54	81	32	0,21
8-XL	F34924	8	2,50	80	115	46	0,61
10-XL	F34934	10	4,00	90	134	56	0,96
13-XL	F34944	13	6,70	117	175	72	2,00
16-XL	F34954	16	10,00	144	214	86	3,57

The **RAPID-Shortening Claw TWN1852** can be assembled and disassembled fast and easily with no additional tools. The ergonomic and compact design enables its positioning at any place on the chain. Two robust locking devices avoid the unsafe release of the chain in a loaded or unloaded condition. The locking device is equipped with a robust spring system.

100% Magnetic Crack Tested. BG-approved.

Finish: RAL 5002

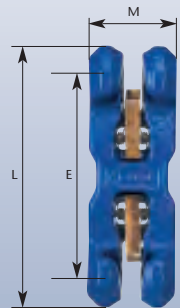

Trade Size	Article-No.	Nominal Size [mm]	Working Load Limit [t max]	Dimensions [mm]			Weight approx. [kgs]
				E	L	M	
6-XL*	F34765	6	1,4	-	-	-	-
8-XL	F34775	8	2,5	111	148	48	0,79
10-XL	F34780	10	4,0	134	180	60	1,50
13-XL	F34785	13	6,7	179	240	78	2,70
16-XL	F34790	16	10,0	222	296	96	4,80

*In development



Attaching the RAPID shortening claw XL to the chain

The following helpful instructions assume the person installing the claw is right-handed. Left-handers can perform the steps shown as a mirror image. The instructions provide only installation information. Other manipulations that achieve the safe positioning of the chain in the two pockets of the shortening claw are possible as well.



1. Positioning the chain in the upper pocket:

Take the shortening claw as in illustrated in **Figure 1** into the right hand and open the upper safety lever with your index finger.

From the bottom, use your left hand to grasp the chain so that the chain link to be placed into the upper pocket is positioned at the lower bow with your index finger and thumb.

Now slide the chain link all the way into the top pocket and release the safety lever.

Check the tightness of the chain in the top pocket.



3. Positioning the chain in the lower pocket:

Take hold of the shortening claw already hanging in the upper pocket with thumb and forefinger of your right hand as shown in **Figure 2** and open the lower safety lever with your middle finger as shown in **Figure 3**.

From the top, use your left hand to grasp the chain so that the chain link to be placed into the lower pocket is held at the upper bow with your index finger and thumb.



Now slide the chain link all the way into the bottom pocket and release the safety lever.

Check the tightness of the chain in the bottom pocket.

Avoid twisting the chains.

Always check the correct positioning after settings the shortening claw and always before each lifting operation!

If correctly assembled, the positioning of the shortening claw corresponds to the structural and nonstructural chain strands in **Figure 4**.



5. Detaching the chain from the lower pocket:

Take hold of the shortening claw with thumb and forefinger of your right hand as shown in **Figure 5** and open the lower safety lever with your middle finger.

Grasp with your left hand the lower chain strand and move it up as indicated by the arrow in **Figure 6**.

Note: Use a little jerk to make removal of the chain from the bottom pocket easier.



Shortening Components XL

The Fixed Size Shortening Device TWN1896

the only one in the world completes the **XL**-assembly system and is automatically determined to the nominal size by the Ringshackle. Therefore, it avoids the possibility of malfunction and provides additional safety for the user.

The high value powder coating provides a longer service life of the shortening device.

Finish: RAL 5002

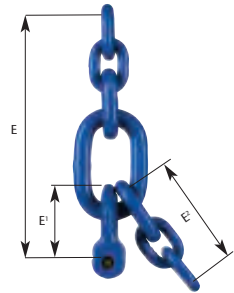

XL

Trade Size	Article-No.	Nominal Size [mm]	Working Load Limit [t max]	Dimensions [mm]				Weight approx. [kgs]
				E	E'	E''	B-Link	
6-XL	F189606	6	1,4	137	31	60	ø10 x 46 x 23	0,32
8-XL	F189608	8	2,5	175	38	78	ø13 x 60 x 30	0,70
10-XL	F189610	10	4,0	215	46	99	ø16 x 70 x 35	1,40
13-XL	F189613	13	6,7	270	59	126	ø18 x 85 x 40	2,60
16-XL	F189616	16	10,0	326	76	150	ø22 x 100 x 50	4,50

Shackle

Bolt Shackle Type C, TWN 1871 dimensionally in accordance with DIN 82101, will be supplied with galvanized bolt, nut and split pin.

100% Magnetic crack tested. BG-approved.

Finish: RAL 5002

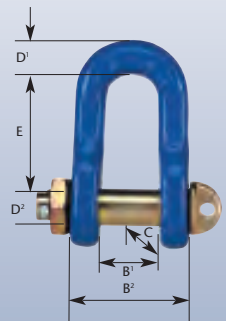

Trade Size	Article-No.	Nominal Size [mm]	Working Load Limit [t max]	Dimensions [mm]						Weight approx. [kgs]
				E	D'	D''	C	B'	B''	
10-XL	F303100	10	4,0	49	15	16	32	21	47	0,45
13-XL	F303200	13	6,7	61	19	20	40	27	61	0,84
16-XL	F303300	16	10,0	73	23	24	48	33	75	1,41



Chain Tensioners XL

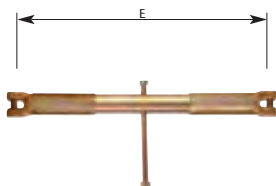

The **Chain Tensioner TWN 1454** is in accordance with standard EN 12195-3 and EN1677-1. Together with other lashing- and connecting components they are basically used in Lashing Chains according to EN 12195-3 for securing of loads in all industry sectors. Additionally, they are suitable for overhead lifting purposes.

The Tensioners achieve a high pre-tension force with less effort because of the screw transmission.

This feature is important for tying down, because only the pretension force is contributing to the securing of loads.

Further advantages can also be mentioned:

- ⊕ A practical dimensioned tensioning hub
- ⊕ Protected screw spindle located inside
- ⊕ Robust protection tubes
- ⊕ Integrated turn off locking mechanism
- ⊕ Clevis type connection on both ends allows easy assembly of the corresponding round steel link chain.
- ⊕ Handle is dimensioned according to EN 12195-3 (ergonomic aspect): Maximum hand pulling force is limited to 500N)
- ⊕ Finish: electro galvanized and yellow chromated

Trade Size	Article-No.	Nominal Size [mm]	norm. straight load (S _{rr}) min. [daN]	tensioner under straight load max. in [daN]	Dimensions [mm]			Weight approx. [kgs]
					E _{max}	E _{min}	stroke	
13-XL	F341877	13	2.600	13.000	675	445	230	7,20
16-XL	F341977	16	3.100	20.000	834	554	280	11,80

suitable for lifting





Chain Tensioners XL

The **Chain Tensioner TWN 1455** is in accordance with standard EN 12195-3 and EN1677-1. Together with other lashing- and connecting components they are basically used in Lashing Chains according to EN 12195-3 for securing of loads in all industry sectors. Additionally, they are suitable for overhead lifting purposes.

The Ratchet Tensioners achieve a high pre-tension force with less effort because of the screw transmission. This feature is important for tying down because only the pretension force is contributing to the securing of loads.

Further advantages can also be mentioned:

- ⊕ A practical dimensioned tensioning hub
- ⊕ Protected screw spindle located inside
- ⊕ Robust protection tubes
- ⊕ Integrated turn off locking mechanism
- ⊕ Clevis type connection on both ends allows easy assembly of the corresponding round steel link chain.
- ⊕ Handle is dimensioned according to EN 12195-3 (ergonomic aspect: Maximum hand pulling force is limited to 500N)
- ⊕ Finish: electro galvanized and yellow chromated

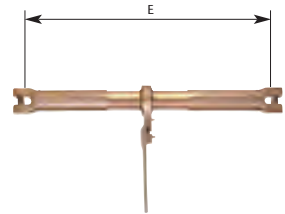

XL

Trade Size	Articel-No.	Nominal Size [mm]	norm. straight load (S _r) min. [daN]	tensioner under straight load max. in [daN]	Dimensions [mm]			Weight approx. [kgs]
					E _{max}	E _{min}	stroke	
13-XL	F341878	13	2.600	13.000	675	445	230	8,40
16-XL	F341978	16	3.100	20.000	834	554	280	13,50
								suitable for lifting





Special Sling Component **XL**

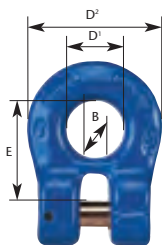

The forged **Ringshackle TWN1812** is automatically determined to the nominal size. It can be used as a lower terminal in the chain sling to be connected to a clevis lashing point. Coupling with a **XL-LOK®** is possible.

100 % Magnetic Crack Tested. BG - approved.

Finish: RAL 5002

Trade Size	Article-No.	Nominal Size [mm]	Working Load Limit [t max]	Dimensions [mm]				Weight approx. [kgs]
				E	D ¹	D ²	B	
6-XL	F31704	6	1,40	31	17	39	8	0,10
8-XL	F31714	8	2,50	37	21	50	11	0,20
10-XL	F31724	10	4,00	46	26	62	14	0,39
13-XL	F31734	13	6,70	59	33	79	18	0,83
16-XL	F31744	16	10,00	75	42	100	23	1,59

Lashing Chains **XL**

Lashing Chain **XL** with tensioner TWN 1410

Standard length L = 3.500 mm, with extended tensioner and unshortened chain. All lengths available upon request. The adjustment will be reached by the shortening device and the tensioner.

according to DIN EN 12195-3



Trade Size	Article-No.	Nominal Size [mm]	admissible tensile strength under straight load [kN]	Weight approx. [kgs]
13-XL	F34183	13	130	21,63
16-XL	F34184	16	200	39,35



Special Sling Component XL

Lashing Chain XL with ratchet TWN 1411

Standard length L = 3.500 mm, with extended tensioner and unshortened chain. All lengths available upon request. The adjustment will be reached by the shortening device and the ratchet tensioner.

according to DIN EN 12195-3



XL

Trade Size	Article-No.	Nominal Size [mm]	admissible tensile strength under straight load [kN]	Weight approx. [kgs]
13-XL	F34183R	13	130	22,83
16-XL	F34184R	16	200	41,05

Spare Parts and Accessories XL

Spare Parts are only available as sets!

Chain Card File XL TWN 0944

To file the regular tests of chains according to EN standards.

Art.-No. Z04575



Assembly Set XL TWN 0945

Consisting of 6 punches in a plastic holder to disassemble chains from components.

The complete set covers all nominal sizes for the use with the THIELE-Sling-Assembly-System.

Art.-No. Z 03303



Tensioning Tag XL TWN 1402 for Lashing Chains,

Article-No. Z07264 (EN 12195-3)



Spare Parts and Accessories XL

Spare Parts are only available as sets!

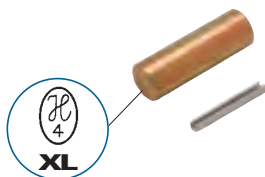

Load Pin **XL**
for Clevis Type Hooks



Spare Parts **XL** TWN 1904/0

for Clevis Type Hooks (Bolt and Spirol Pin)

Trade Size	Article-No.	Packing Units	Weight approx. [kgs]
6-XL	F48686	1 set	0,01
8-XL	F48687	1 set	0,01
10-XL	F48688	1 set	0,03
13-XL	F48689	1 set	0,07
16-XL	F48690	1 set	0,11



Spare Parts **XL** for Sling Hooks

Spare Parts **XL** TWN 1908/0

for Sling Hooks (Safety Latch, spring and Spirol Pin)

Trade Size	Article-No.	Packing Units	Weight approx. [kgs]
6-XL	F48731	1 set	0,03
8-XL	F48733	1 set	0,06
10-XL	F48735	1 set	0,11
13-XL	F48737	1 set	0,19
16-XL	F48739	1 set	0,32



(TWN 1835/1) (TWN 1840/1) (TWN 1841/1)



Spare Parts and Accessories XL

Spare Parts are only available as sets!

Spare Parts XL TWN 1929/0

for XL-LOK® (Bolt and 2 Spirol Pins)

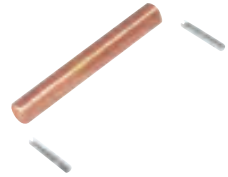

XL

Pin Set for XL-LOK®

Trade Size	Article-No.	Packing Units	Weight approx. [kgs]
6-XL	F486011	1 set	0,01
8-XL	F486041	1 set	0,02
10-XL	F486071	1 set	0,03
13-XL	F486101	1 set	0,06
16-XL	F486131	1 set	0,12



XL-LOK®, TWN 1829)

Spare Parts XL TWN 1930/0

for C-Shackle, TWN 1871 (Bolt, Nut and Cotter Pin)



Pin Set for C-Shackle

Trade Size	Article-No.	Packing Units	Weight approx. [kgs]
10-XL	F304510	1 set	0,13
13-XL	F304610	1 set	0,25
16-XL	F304710	1 set	0,36



(TWN 1871)

Spare Parts and Accessories XL

Spare Parts are only available as sets!



Trigger Set for RAPID® Shortening Claw



RAPID®, (TWN 1852)

Spare Parts XL TWN 1931/0

for RAPID® Shortening Claw, TWN 1852 (2 Retainers, 2 Springs and 2 Spirol Pins)

Trade Size	Article-No.	Packing Units	Weight approx. [kgs]
8-XL	F347750	1 set	0,04
10-XL	F347800	1 set	0,10
13-XL	F347850	1 set	0,17
16-XL	F347900	1 set	0,33



Pin Set for Clevis Self Locking Hook



(TWN 1837)

Spare Parts XL TWN 1933/0

for Clevis Self Locking Hook, TWN 1837 (Load Pin, 2 Spirol Pins)

Trade Size	Article-No.	Packing Units	Weight approx. [kgs]
6-XL	F092001	1 set	0,01
8-XL	F092011	1 set	0,02
10-XL	F092021	1 set	0,04
13-XL	F092031	1 set	0,08
16-XL	F092041	1 set	0,16



Spare Parts and Accessories XL

Spare Parts are only available as sets!

Trigger Set XL TWN 1935

for Self Locking Hooks (TWN 1836, TWN 1837 and TWN 1838)
(Retainer, Spring, Assembly Plastic Bush and Spirol Pin)



XL

Trigger Set for Self Locking Hooks

Trade Size	Article-No.	Packing Units	Weight approx. [kgs]
6-XL	F092202	1 set	0,02
8-XL	F092212	1 set	0,04
10-XL	F092222	1 set	0,05
13-XL	F092232	1 set	0,18
16-XL	F092242	1 set	0,19



(TWN 1836) (TWN 1837) (TWN 1838)





Spare Parts and Accessories **XL**

Spare Parts are only available as sets!



Identification Tag **XL** TWN 1940 for Chain Slings **XL**



Pic.: TWN 1940
Front- and Backside

Article-No. Single Leg + Multi Leg	Type	Weight approx. [kgs]
F08052	without welded ring	0,10
F08053	with welded ring	0,10



Chain Gauge **XL** TWN 1946 for Round Steel Link Chains **XL**



Pic.: TWN 1946
Front- and Backside

Trade Size	Article-No.	Weight approx. [kgs]
6-XL	F01690	0,10
8-XL	F01691	0,15
10-XL	F01692	0,20
13-XL	F01693	0,25
16-XL	F01694	0,30



Examples for Chain Slings **XL**

1-Leg Chain Slings **XL** with **XL-LOK**®-coupling

TWN 1600



TWN 1601



XL

TWN 1602



TWN 1603



TWN 1604





Examples for Chain Slings **XL**

2-Leg Chain Slings **XL** with **XL-LOK**®-coupling

TWN 1650



TWN 1651



TWN 1652



TWN 1653



TWN 1654





Examples for Chain Slings XL

4-Leg Chain Slings XL with XL-LOK®-coupling

TWN 1750



TWN 1751



XL

TWN 1752



TWN 1753



TWN 1754





Examples for Chain Slings **XL**

1-Leg Chain Slings **XL**, Fixed Size

TWN 1631



TWN 1632



2-Leg **XL**-Chain Slings, Fixed Size

TWN 1681



TWN 1682





Examples for Chain Slings **XL**

4-Leg Chain Slings **XL**, Fixed Size

TWN 1781



TWN 1782



XL



Shortening Options





Endless Chains XL

Form K11

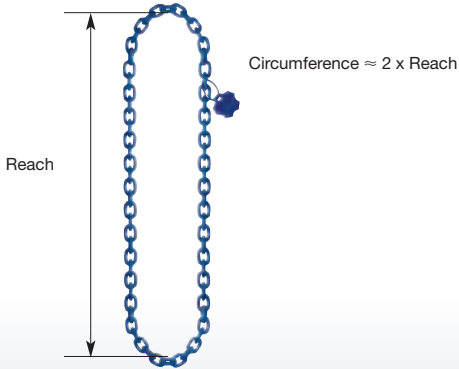

Form K12



Form K22



Operating Manual

WARNING!

- Chain Slings and Components can only be used, if user instructions and operating instructions have been read carefully and are completely understood.
- The indicated values of loads on the I.D. tags must not be exceeded.
- Due to improper use, chains can fail.

IT'S A QUESTION OF YOUR SAFETY
Death or injury can occur from improper use or maintenance!

1. Transport and Storing

All products must be protected during transportation, use, and storage in severe weather conditions.

2. Before first use

Assembling, disassembling and using should only be accomplished by authorized persons according to BGR 500, Chapter 2.8 (In Germany)

- Check the following points before using the chain sling for the first time:
 - all test certificates exist (declaration of conformity, inspection certificate 3.1.B etc.); the chain sling you are going to use is the same that you ordered
 - Chain slings and Lashing Chains are provided with the CE label
 - identification and working load limit marked on the chain sling are identical to the corresponding information indicated on the test certificate; all details concerning the chain sling have been entered into the chain card file
 - The assembly is prohibited until it has been found out, that the machine in which should be built in, corresponds with the EC Directive for machines and its amendments (European rules and regulations).
 - In suitable intervals, check the chain sling for damages or wear (depending upon severity of conditions slings shall be inspected for damage as frequently as prior to each lift. All supplied user instructions must be maintained and available for reference until the product is removed from service.

3. Warning and use advice

- EC Directive for Machines and its amendments as per 2006/42/EG
- Operation and use instructions for chain slings according to DIN 685 - 5, EN 818 - 6.
- Consult safety regulations for round Steel Link Chains used as slinging gear in hot dipped galvanizing plants (german rules and regulations) according to BGR 150
- Consult Safety Regulations for Cranes according to BGV D 6
- Consult load Suspension Devices for Lifting Operations (german rules and safety regulations) according to BGR 500, Chapter 2.8
- Consult Safety certificate for riggers according to BGI 556
- Consult components for chain slings according to EN 1677-2
- Consult principles for test of industrial safety of lifting products
- Consult slinging of rod iron using steel round Steel Link Chains when loading and unloading sea-going ships

- Consult German rules and regulations VDI 2700-2701-2702
- Special Sling Components, hooks and clutching devices should only be used in straight tensile direction

Especially forbidden is:

- the combination of different grades when assembling (except tongs)
- the using of chain slings which do not correspond to grade 100
- overloading
- To use a combination of products with different working load limits, unless the working load noted on the I.D. tag is based on the weakest component.
- the use of twisted or knotted chains
- to use bolts or wires to connect components
- to use deformed components, rigid or elongated chains
- to lift or pull loads with sharp edges without padding the edges
- to drive equipment over chain sling
- to multiple wrap a chain around a loadhook or tension point
- to modify products by welding, burning, bending or other mechanical modifications
- to make inadmissible modifications, e.g. the use of a 2-leg chain sling with shortening hooks as a 4-leg chain sling
- to tip load a hook into a chain link
- to apply the load on the tip, side or back of the hook
- to load connectors (XL-Lok s) on one side
- to adjust chain links or products
- to adapt inclination over 60°
- to turn swivels or swivel hooks under load
- to weld transport ring screw type lifting eyes
- to exceed the indicated grip on lifting tongs
- the use of open or riveted lifting links

It must be taken into consideration:

- the load to be lifted
- the free mobility of the hook's safety latches
- the use under chemical influences for example acids and steam is restricted or prohibited
- the influence of temperature on alloy chain and components
- shock load impacts the chain or fitting while lifting or securing
- any type of surface treatment to chain or fittings especially of hot dipped galvanizing can only be carried out by the manufacturer
- when lifting keep hands and other parts of body far away from the components
- be careful when locking hooks under load
- Danger of injury!
- when not in use chain slings shall be hung on a rack
- ensure free mobility of chain slings or other devices in the crane hook
- when using hooks without latches pay special attention to the position of the hook placement
- to the installation position
- if necessary protect screw tensioners by locking elements to prevent automatic unlocking
- load claws with chains only on the bottom of the pocket claws
- protect chain by padding or wrapping sharp edges
- Safety latches should not be obstructed when hooks are loaded

- in case of shortening hooks, load chains must be loaded in the bowl of the hook
- hook openings must point away from the load being lifted
- that the hook up point and lifting hooks are compatible
- also be sure that the lifting components are suitable for the application
- do not sit loads on the chain sling
- reduction of working load limits is necessary when making lifts at severe angles
- consult charts when using alloy chain at extreme temperatures
- working load limits must be reduced when using endless and basket slings
- extreme caution should be used when using hooks for lifting molten metal or chemicals
- chain slings shall be loaded properly to avoid damage to chain and load
- keep personnel away from loads being lifted

4. Maintenance and tests

- The chain sling must be visually inspected before use. If damage is found, you must consult a chain expert according to BGR 500.
- The product must be removed from service if the following damage is found:
 - unreadable tags
 - breaks or deformation
 - cuts, notches, grooves or cracks
 - strong corrosion
 - heating over the admissible temperature allowed
 - elongation of chain must not exceed 5% of manufacturer's published size
 - elongation of the overall chain length shall not exceed 5%
 - to determine wear rejection on the diameter of a link, you must measure the horizontal and the vertical and reject if reduction is more than 10%.
 - reject hooks if throat opening is opened greater than 10% of new hook or the safety latch does not seat properly
 - wear of hook eye or hook body exceed 5%
 - missing or damaged safety latch of the hook or shortening component
 - incorrect screw replacement on lifting eyes
 - incorrect or damaged bolts or turn off locking
- Don't repair chain slings yourself unless fully trained. Please contact the manufacturer or a repair expert. Use only original spare parts from THIELE.

5. Regular inspections

- Regular inspection shall include measurement and visual inspection and should be carried out once each year at minimum. Each third year inspection must include the crack detection (magna flux).
- On a new chain, you must set up chain card index that shall contain a description of the chain as well as the identity of the certificate. The inspection schedule must be fixed. The condition of chain slings or lashing chains and their components shall be noted at each inspection. If damage is repaired, all repairs and details must be noted on the chain card.

Download: www.thiele.de



THIELE

App



THIELE



GK

Lifting Products Grade 80



Product Overview **GK8**

TWN 0805

Page 70 Round Steel Link Chains **GK8**

TWN 0795	TWN 0796	TWN 0797	TWN 0803	TWN 0804
TWN 0807	TWN 0808	TWN 0809	TWN 0810/1	TWN 0810/2
TWN 0810/4	TWN 0811/1	TWN 0811/2	TWN 0811/4	TWN 0815
TWN 0816	TWN 0817	TWN 0820		

Page 71-79 Master Links **GK8**

TWN 0829

Page 79 THI-LOK® Connector **GK8**



Product Overview **GK8**

TWN 0798	TWN 0799	TWN 1340/1	TWN 0835/1	TWN 0854
				
TWN 0855	TWN 0855/1	TWN 0856	TWN 0858/1	TWN 0859
				
TWN 0860	TWN 0868	TWN 0872	TWN 0873	TWN 0887
				
TWN 0889				
				

GK8

Page
80-85

Hooks GK8







TWN 0827	TWN 0827/1	TWN 0851	TWN 0896	
				

Page
86-87



Shortening Components GK8



Product Overview **GK8**

	<p>TWN 0861</p> 	<p>TWN 0862</p> 	<p>TWN 0870</p> 	<p>TWN 0871</p> 	<p>TWN 0897</p> 
	<p>TWN 0898</p> 	<p>TWN 0898/1</p> 			













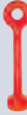

Page 87-89 **Shackles GK8**

	<p>TWN 1450</p> 	<p>TWN 1451</p> 	<p>TWN 1452</p> 	
--	---	---	---	--

Page 90 **Chain Tensioners GK8**



Product Overview **GK8**

TWN 0812	TWN 0845	TWN 0869	TWN 0875	TWN 0882
				
TWN 0892	TWN 0893	TWN 0894	TWN 0895	TWN 0940
				
TWN 0944	TWN 0945	TWN 0946	TWN 1402	
				
TWN 1400				
TWN 1401				

GK8



Product Overview GK8

<p>TWN 0904/0</p> 	<p>TWN 0905/0906</p> 	<p>TWN 0920-0922</p> 	<p>TWN 0929</p> 	<p>TWN 0930-0932</p> 
<p>TWN 0950-0952</p> 	<p>TWN 0962</p> 	<p>TWN 0967/0</p> 	<p>TWN 0967/1</p> 	<p>TWN 1908/5</p> 
<p>TWN 0941</p> 				

Page 98

Spare Parts and Accessories GK8

<p>Form K11</p> 	<p>Form K12</p> 	<p>Form K22</p> 	
--	--	--	--

Page 104

Endless Chains GK8

<p>TWN 0449</p> 	<p>TWN 0536</p> 	<p>TWN 0710/1</p> 	
---	---	---	--

Page 106

Chain Slings GK8

	<p>Marine and Offshore</p>
---	----------------------------

Page 109



Selection Criteria

GK8-Program

Selection Criteria for Grade 80 Sling Chains

1. Determine the **weight of the load** (to be lifted).
2. Check **number of chain-legs** required (depending on the number of existing lifting points.)
3. Determine the **chain size** by taking the “**Inclination Angle**” into consideration.
(See table 1 page 67, table 2 page 68, table 3 page 69)
4. Consider possible (extreme) **temperature influences**. (See table 4 page 70)
5. Consider that “**asymmetry**” may influence the load factor. (See table 5 page 70)
6. Determine the **chain length** by considering the total-effective-reach.
7. Control (inspect) selected components and/or in-use container slings to insure that they meet or exceed all applicable industry and government safety-laws and regulations.



Special advices:

Please, also consider more complicated conditions of use, such as intermittent impacts or loads when selecting the slings and/or components. Sling chains and components are not allowed to be used over 400°C temperature. If, however your components should be misfired by mistake above the temperature of 400°C, you should contact immediately the manufacturer in order to check the components to their operational integrity. The THIELE assembly system must not be used in the case of chemical influences like acids and/or lyes.

THIELE Plant Standard (TWN)

THIELE Plant Standard fulfill the requirements of the EG Directive for Machines, particularly for the safety relevant components.

The Working Load Limit and the test requirements are more strict than the European standards.



Identification Tag **GK8**



The tally according to EN 818-4 for chain slings Grade 80 has an octagonal shape for easy identification.

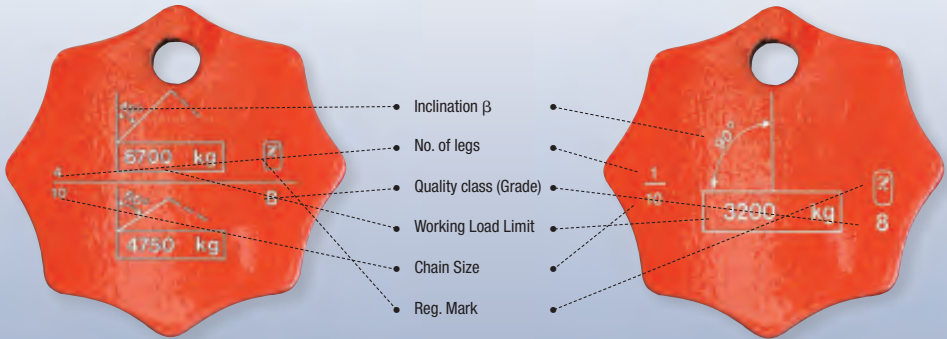



Legal marking of Grade 80 chains by the German professional association

The number 4 under the H only represent a registration number of the German professional association and helps in case of damage to find the manufacture of the chain. The marking is also recognized from all international certification societies as well as from work authorities etc. among others A. I. B. Brüssel.

Working Load Limit in [t]

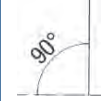
Direct sling

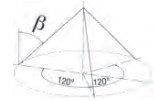
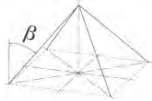
Table 1		1-leg		2-leg		3- and 4-leg	
							
Inclination Angle		$\beta = 0^\circ$	$0^\circ < \beta \leq 45^\circ$	$45^\circ < \beta \leq 60^\circ$	$0^\circ < \beta \leq 45^\circ$	$45^\circ < \beta \leq 60^\circ$	
Load Factor		1	1,4	1	2,1	1,5	
Trade Size	Nominal Size [mm]						
6-8	6	1,12	1,60	1,12	2,36	1,70	
7-8	7	1,50	2,12	1,50	3,15	2,24	
8-8	8	2,00	2,80	2,00	4,25	3,00	
10-8	10	3,15	4,25	3,15	6,70	4,75	
13-8	13	5,30	7,50	5,30	11,20	8,00	
16-8	16	8,00	11,20	8,00	17,00	11,80	
18-8	18	10,00	14,00	10,00	21,20	15,00	
20-8	20	12,50	17,00	12,50	26,50	19,00	
22-8	22	15,00	21,20	15,00	31,50	22,40	
26-8	26	21,20	30,00	21,20	45,00	31,50	
28-8*	28	25,00	33,50	25,00	50,00	37,50	
32-8	32	31,50	45,00	31,50	67,00	47,50	
36-8*	36	40,00	56,00	40,00	85,00	60,00	
40-8*	40	50,00	71,00	50,00	106,00	75,00	
45-8*	45	63,00	90,00	63,00	132,00	95,00	
50-8*	50	80,00	112,00	80,00	168,00	120,00	
56-8*	56	100,00	140,00	100,00	210,00	150,00	

Inclination Angles β over 60° are prohibited: All other sizes are also available in welded finish on request.

Note: German regulations states than 3 and 4-leg slings having the same working loads.

* These sling chains are only available in welded construction.

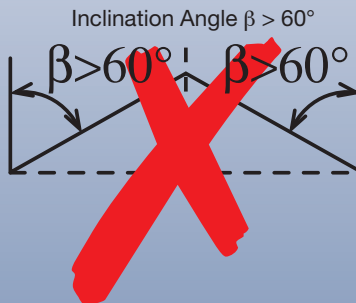

Can fail if damaged, misused or overloaded. Inspect before use. Use only if trained. Observe rated capacity in table 1, 2, 3. DEATH or INJURY can occur from improper use or maintenance.



Choke Hitch

Table 2		1-leg	2-leg		endless chain looped
Inclination Angle		$\beta = 0^\circ$	$0^\circ < \beta \leq 45^\circ$	$45^\circ < \beta \leq 60^\circ$	
Load Factor		0,8	1,12	0,8	1,6
Trade Size	Normal-Size [mm]				
6-8	6	0,90	1,25	0,90	1,80
7-8	7	1,25	1,70	1,25	2,50
8-8	8	1,60	2,24	1,60	3,15
10-8	10	2,50	3,55	2,50	5,00
13-8	13	4,25	6,00	4,25	8,50
16-8	16	6,30	9,00	6,30	12,50
18-8	18	8,00	11,20	8,00	16,00
20-8	20	10,00	14,00	10,00	20,00
22-8	22	11,80	17,00	11,80	23,60
26-8	26	17,00	23,60	17,00	33,50
28-8*	28*	20,00	28,00	20,00	40,00
32-8	32	25,00	35,50	25,00	50,00
36-8*	36*	31,50	45,00	31,50	63,00
40-8*	40*	40,00	56,00	40,00	80,00
45-8*	45*	50,00	71,00	50,00	100,00
50-8*	50*	63,00	90,00	63,00	125,00
56-8*	56*	80,00	112,00	80,00	160,00

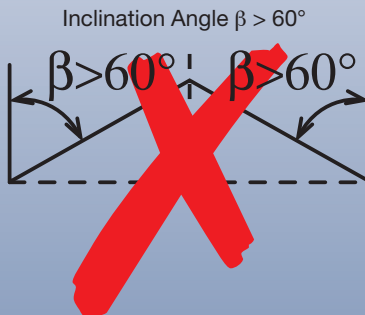

Inclination Angles β over 60° are prohibited: All other sizes are also available in welded finish on request.
 *These sling chains are only available in welded construction.



Can fail if damaged, misused or overloaded. Inspect before use. Use only if trained. Observe rated capacity in table 1, 2, 3. DEATH or INJURY can occur from improper use or maintenance.

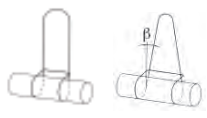
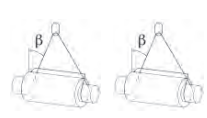

Endless Chains

Table 3		K11		K12	K13	K22	K23
							
Inclination Angle		$\beta = 0^\circ$	$0^\circ < \beta \leq 25^\circ$	$0^\circ < \beta \leq 45^\circ$	$45^\circ < \beta \leq 60^\circ$	$0^\circ < \beta \leq 45^\circ$	$45^\circ < \beta \leq 60^\circ$
Load Factor		1,6	1,45	1,13	0,8	1,7	1,2
Trade Size	Nominal Size [mm]						
6-8	6	1,80	1,60	1,25	0,90	1,90	1,32
7-8	7	2,50	2,24	1,70	1,25	2,65	1,80
8-8	8	3,15	2,80	2,24	1,60	3,35	2,36
10-8	10	5,00	4,50	3,55	2,50	5,30	3,75
13-8	13	8,50	7,50	6,00	4,25	9,00	6,30
16-8	16	12,50	11,80	9,00	6,30	13,20	9,50
18-8	18	16,00	15,00	11,20	8,00	17,00	11,80
20-8	20	20,00	18,00	14,00	10,00	21,20	15,00
22-8	22	23,60	22,40	17,00	11,80	25,00	18,00
26-8	26	33,50	30,00	23,60	17,00	35,50	25,00
28-8	28	40,00	35,50	28,00	20,00	42,50	30,00
32-8	32	50,00	47,50	35,50	25,00	53,00	37,50
36-8	36	63,00	60,00	45,00	31,50	67,00	47,50
40-8	40	80,00	71,00	56,00	40,00	85,00	60,00
45-8	45	100,00	90,00	71,00	50,00	106,00	75,00



Round Steel Link Chains **GK8** TWN 0805

Reduced Safe Working Load of Round Steel Link Chains

If Grade 80 - Alloy Slings are used at temperatures exceeding 200°C, then the Working Load Limit has to be reduced acc. to Table 4.

Table 4: Temperature

Safe Working Load indicated in % acc. to Tables 1, 2 or 3 by chain temperatures of:

- 40 to + 200°C	over 200 to 300°C	over 300 to 400°C
100	90	75

Before using the Alloy Slings at temperatures below - 40°C, the manufacturer has to be consulted.

Table 5: Asymmetry

No. of legs	1		2		3		4	
Inclination β max.	-	0° - 45°	46° - 60°		0° - 45°	46° - 60°	0° - 45°	46° - 60°
Load factor	1	1	1		1,4	1	1,4	1



Trade Size	Art.-No.			Nominal Size		Pitch		Inside width [w ₁] min.	Outside width [w ₂] max.	Working Load Limit [t]	Weight app. [kgs]
	self- coloured	RAL 9005	corrothiel	[d]	Abw./ tol. ±	[p]	Abw./ tol. ±				
6-8	F01452	F01453	F01454	6,00	0,24	18,00	0,5	7,80	22,20	1,12	0,8
7-8	F01458	F01459	F01457	7,20	0,20	21,80	0,6	9,45	25,20	1,50	1,1
8-8	F01464	F01465**	F01429	8,00	0,32	24,00	0,7	10,40	29,60	2,00	1,4
10-8	F01469	F01470**	F01450	10,00	0,40	30,00	0,9	13,00	37,00	3,15	2,2
13-8	F01474	F01475**	F01476	13,00	0,52	39,00	1,2	16,90	48,10	5,30	3,8
16-8	F01479	F01480	F01487	16,00	0,64	48,00	1,4	20,80	59,20	8,00	5,7
18-8	F01484	F01485	F04580	18,00	0,90	54,00	1,6	23,40	66,60	10,00	7,3
20-8	F01494	F01495	F04606	20,00	1,00	60,00	1,8	26,00	74,00	12,50	9,0
22-8	F01499	F01500	F04629	22,00	1,10	66,00	2,0	28,60	81,40	15,00	10,9
26-8	F01514	F01515	F04695	26,00	1,30	78,00	2,3	33,80	96,20	21,20	15,2
28-8*	F01519	F01520	F01521	28,00	1,40	84,00	2,5	36,40	104,00	25,00	17,6
32-8	F01524	F01525	F01526	32,00	1,60	96,00	2,9	41,60	118,00	31,50	23,0
36-8	F01529	F01530	F04814	36,00	1,80	108,00	3,0	46,80	133,00	40,00	29,0
40-8*	F01534	F01535	F04838	40,00	2,00	120,00	4,0	52,00	148,00	50,00	36,0
45-8*	F01539	F01540	F04889	45,00	2,30	135,00	4,0	58,50	167,00	63,00	45,5
50-8*	F01545	F01546	F04900	50,00	2,50	150,00	4,5	67,50	180,00	80,00	56,0
56-8*	F01555	F01556	F04908	56,00	2,80	170,00	5,0	75,60	201,60	100,00	72,5
63-8*	-	F01566	-	63,00	3,20	190,00	6,0	88,00	230,00	125,00	89,0

* These sling chains are only available in welded finish

**TOP-Articles (see page 13)

Elongation at break, self coloured, min. 25%; bright finished min 20%.

Factor "Working Load Limit" : Proof Force = Breaking Force = 1 : 2,5 : 4 (200 : 500 : 800 N/mm²);

Suspension Components

THIELE Components of the GK8 Assembly System have a Safety Factor of 4.
The Components comply with all present standards like EN 818, EN 1677 and DIN 5688-3.

New

Dimension	Art.-No.	Working Load Limit [t]	Dimensions [mm]						Weight app. [kgs]	TWN 0795
			D	F	B					
B 8	F122880	1,12	8	36	18				0,05	
B 10	F122890	2,00	10	46	23				0,09	
B 13	F122930	3,15	13	60	30				0,20	
B 16	F122970	5,30	16	70	35				0,36	
B 18	F123010	6,70	18	85	40				0,54	
B 20	F123030	8,00	20	90	45				0,73	
B 22	F123070	10,00	22	100	50				0,97	
B 26	F123090	12,50	26	120	60				1,60	
B 28	F123190	15,00	28	130	65				1,90	
B 32	F123110	21,20	32	140	70				2,90	
B 36	F123130	25,00	36	160	80				4,20	
B 40	F123150	31,50	40	180	90				5,80	
B 45	F123170	40,00	45	200	100				8,20	
B 50	F123210	50,00	50	220	110				11,00	
B 56	F123230	63,00	56	260	130				16,00	
B 63	F123270	80,00	63	280	140				22,00	
B 70	F123290	100,00	70	320	160				31,00	
B 80	F123300	125,00	80	360	180				46,50	
B 90	F123320	160,00	90	400	200				65,50	



GK8

Intermediate Master Link
Type B
according to DIN 5688-3

Art.-No.	Working L. L. $\beta = 0^\circ - 45^\circ$ [t] SF= 1:4	Dimensions [mm]								Weight app. [kgs]	Categorization of the wire rope diameter*		TWN 0796
		E	D	F	B	D ₁	F ₁	B ₁	Fiber Rope [mm]		Steel Rope [mm]		
F0796016	2,80	200	16	110	60	13	90	50	1,20	11,00	10,00		
F0796018	4,00	240	18	130	70	16	110	60	1,90	13,00	12,00		
F0796022	5,30	290	22	160	90	18	130	70	3,10	14,00	14,00		
F0796026	7,50	340	26	180	100	22	160	90	5,40	18,00	16,00		
F0796032	11,10	410	32	230	125	26	180	100	9,10	22,00	20,00		
F0796036	16,00	480	36	250	140	32	230	125	15,10	26,00	24,00		
F0796045	21,00	570	45	320	175	36	250	140	25,00	28,00	28,00		
F0796050	31,60	660	50	340	190	45	320	175	42,00	36,00	36,00		
F0796056	40,20	720	56	380	210	50	340	190	57,00	40,00	40,00		
F0796063	50,10	810	63	430	240	56	380	210	79,00	44,00	44,00		
F0796085	101,80	1040	85	520	290	80	520	290	202,00	60,00	60,00		



Master Link Assembly
for 3 and 4 Leg
Wire Rope EN 13414-1

*according to DIN EN 13414-1 for 3/4 leg slings

Suspension Components (Offshore)

New

Art.-No.	Working L. L. $\beta = 0^\circ - 45^\circ$ [t] SF= 1:4	Dimensions [mm]							Weight app. [kgs]			TWN 0797
		E	D	F	B	D ₁	F ₁	B ₁				
F0797268	7,90	340	26	180	100	22	160	90	5,30			 <p>Offshore Master Link Assembly for 3 and 4 Leg Wire Rope</p>
F0797328	11,30	410	32	230	125	26	180	100	9,00			
F0797368	16,00	480	36	250	140	32	230	125	15,00			
F0797458	22,60	570	45	320	175	36	250	140	24,40			
F0797508	26,80	660	50	340	190	45	320	175	40,00			
F0797568	40,00	720	56	380	210	50	340	190	55,00			
F0797638	50,00	810	63	430	240	56	380	210	79,00			

*according to DNV 2.7-1:2006-04



Suspension Components (Offshore)

New

Art.-No.	Working Load Limit [t]	Dimensions [mm]						Weight app. [kgs]
		D	F	B				
F0803208	4,75	20	140	80				1,10
F0803228	5,60	22	160	90				1,50
F0803268	8,00	26	180	100				2,30
F0803328	12,50	32	230	125				4,40
F0803368	16,00	36	250	140				6,20
F0803408	19,00	40	290	160				8,80
F0803458	25,00	45	320	175				12,00
F0803508	31,50	50	340	190				16,00
F0803568	40,00	56	380	210				23,00
F0803638	50,00	63	430	240				33,00
F0803708	63,00	70	470	260				44,00
F0803808	80,00	80	520	290				64,00

Further dimensions forgings on request

TWN 0803



Offshore
Oblong Master Link
Type A

New

Art.-No.	Working Load Limit [t]	Dimensions [mm]						Weight app. [kgs]
		D	F	B				
F0804138	3,35	13	60	30				0,20
F0804168	5,60	16	70	35				0,36
F0804208	8,50	20	90	45				0,73
F0804228	10,00	22	100	50				0,97
F0804268	14,00	26	120	60				1,60
F0804288	16,00	28	130	65				1,90
F0804328	22,40	32	140	70				2,90
F0804368	28,00	36	160	80				4,20
F0804408	33,50	40	180	90				5,80
F0804458	42,50	45	200	100				8,20
F0804508	53,00	50	220	110				11,00

Further dimensions forgings on request

TWN 0804



Offshore
Intermediate Master Link
Type B
according to DIN 5688-3



Suspension Components

Trade Size	Art.-No.	Nominal Size [mm]	Working Load Limit [t]	Dimensions [mm]							Weight app. [kgs]	TWN 0807
				D	F	B	*					
6-8	F0807068	6	1,12	13	90	50	1,6				0,29	
8-8	F0807088	8	2,00	16	110	60	2,5				0,53	
10-8	F0807108	10	3,15	18	130	70	4				0,79	
13-8	F0807138	13	5,30	22	160	90	6				1,50	
16-8	F0807168	16	8,00	26	180	100	8				2,30	
18-8	F0807188	18	10,00	32	230	125	12				4,40	
20-8	F0807208	20	12,50	32	230	125	12				4,40	
22-8	F0807228	22	15,00	36	250	140	16				6,20	
26-8 *	F0807268	26	21,20	45	320	175	25				12,00	
28-8 *	F0807288	28	25,00	45	320	175	25				12,00	
32-8	F0807328	32	31,50	50	340	190	25				16,00	
36-8	F0807368	36	40,00	56	380	210	32				23,00	
40-8	F0807408	40	50,00	63	430	240	40				33,00	
45-8	F0807458	45	63,00	70	470	260	50				44,00	
50-8	F0807508	50	80,00	80	520	290	63				64,00	
56-8	F0807568	56	100,00	85	520	290	63				73,00	
63-8	F0807638	63	125,00	95	580	320	80				100,00	
71-8	F0807718	71	160,00	110	680	380	100				160,00	
80-8	F0807808	80	200,00	125	720	400	125				220,00	

*fits with single crane hook as per standard DIN 15401 No. / further dimensions on request

Oblong Master Link Type A
for Single Leg Slings

Trade Size	Art.-No.	Nominal Size [mm]	Working Load Limit [t]	Dimensions [mm]							Weight app. [kgs]	TWN 0808
				D	F	B	*					
6-8	F0808068	6	1,60	13	90	50	1,6				0,29	
8-8	F0808088	8	2,80	18	130	70	4				0,79	
10-8	F0808108	10	4,25	20	140	80	5				1,10	
1-8	F0808138	13	7,50	26	180	100	8				2,30	
16-8	F0808168	16	11,20	32	230	125	12				4,40	
18-8	F0808188	18	14,00	36	250	140	16				6,20	
20-8	F0808208	20	17,00	40	290	160	20				8,80	
22-8 *	F0808228	22	21,20	45	320	175	25				12,00	
26-8	F0808268	26	30,00	50	340	190	25				16,00	
28-8	F0808288	28	33,50	56	380	210	32				23,00	
32-8	F0808328	32	45,00	63	430	240	40				33,00	
36-8	F0808368	36	56,00	70	470	260	50				44,00	
40-8	F0808408	40	71,00	80	520	290	63				64,00	
45-8	F0808458	45	90,00	85	520	290	63				73,00	
50-8	F0808508	50	112,00	95	580	320	80				100,00	
56-8	F0808568	56	140,00	110	680	380	100				160,00	

*fits with single crane hook as per standard DIN 15401 No. / further dimensions on request

Oblong Master Link Type A
for Double Leg Slings

Suspension Components

Trade Size	Art.-No.	Nominal Size [mm]	Working L. L. $\beta = 0^\circ - 45^\circ$ [t]	Dimensions [mm]										Weight app. [kgs]	TWN 0809
				E	D	F	B	D ₁	F ₁	B ₁	*				
6-8	F0809068	6	2,36	170	16	110	60	13	60	30	2,5	0,94			
8-8	F0809088	8	4,25	210	20	140	80	16	70	35	5	1,80			
10-8	F0809108	10	6,70	270	26	180	100	20	90	45	8	3,80			
13-8	F0809138	13	11,20	350	32	230	125	26	120	60	12	7,70			
16-8	F0809168	16	17,00	420	40	290	160	28	130	65	20	13,00			
18-8*	F0809188	18	21,20	460	45	320	175	32	140	70	25	18,00			
20-8	F0809208	20	26,50	500	50	340	190	36	160	80	25	25,00			
22-8	F0809228	22	31,50	520	50	340	190	40	180	90	25	28,00			
26-8	F0809268	26	45,00	630	63	430	240	45	200	100	40	49,00			
28-8	F0809288	28	50,00	630	63	430	240	45	200	100	40	49,00			
32-8	F0809328	32	67,00	740	80	520	290	50	220	110	63	86,00			
36-8	F0809368	36	85,00	780	85	520	290	56	260	130	63	106,00			
40-8	F0809408	40	106,00	860	95	580	320	63	280	140	80	146,00			
45-8	F0809458	45	132,00	1000	110	680	380	70	320	160	100	223,00			
50-8	F0809508	50	160,00	1040	110	680	380	80	360	180	100	252,00			
56-8	F0809568	56	200,00	1120	125	720	400	90	400	200	125	350,00			

*fits with single crane hook as per standard DIN 15401 No. / further dimensions on request

Master Link Assembly for 3- and 4-Leg Slings

Remark:

The product type TWN0795, 0796, 0807, 0808, 0809 comply with the currently valid standard EN1677-4 (March 2009) and replace the product type TWN0823, 0828, 0831, 0832, 0833.

Suspension Components

Trade Size	Art.-No.	Nominal Size [mm]	Working L. L. [t]	Dimensions [mm]						Weight app. [kgs]	TWN 0810/1
				E	D	F	B				
6-8	F08101068	6	1,12	121	13	90	50			0,40	
8-8	F08101088	8	2,00	147	16	110	60			0,80	
10-8	F08101108	10	3,15	176	18	130	70			1,20	
13-8	F08101138	13	5,30	219	22	160	90			2,30	
16-8	F08101168	16	8,00	255	26	180	100			4,00	
22-8	F08101228	22	15,00	350	36	250	140			10,0	
for single leg slings											

Trade Size	Art.-No.	Nominal Size [mm]	Working L. L. $\beta = 0^\circ - 45^\circ$ [t]	Dimensions [mm]						Weight app. [kgs]	TWN 0810/2
				E	D	F	B				
6-8	F08102068	6	1,60	121	13	90	50			0,50	
8-8	F08102088	8	2,80	167	18	130	70			1,20	
10-8	F08102108	10	4,25	206	22	160	90			1,90	
13-8	F08102138	13	7,50	239	26	180	100			4,00	
16-8	F08102168	16	11,20	305	32	230	125			7,60	
22-8	F08102228	22	21,20	420	45	320	175			19,60	
for double leg slings											

Trade Size	Art.-No.	Nominal Size [mm]	Working L. L. $\beta = 0^\circ - 45^\circ$ [t]	Dimensions [mm]						Weight app. [kgs]	TWN 0810/4
				E	D	F	B	D ₁			
6-8	F08104068	6	2,36	201	16	110	60	13		1,40	
8-8	F08104088	8	4,25	267	22	160	90	16		2,70	
10-8	F08104108	10	6,70	316	26	180	100	20		5,40	
13-8	F08104138	13	11,20	409	32	230	125	26		11,10	
16-8	F08104168	16	17,00	495	40	290	160	28		19,00	
22-8	F08104228	22	31,50	620	50	340	190	40		42,80	
for four leg slings											

Suspension Components

Trade Size	Art.-No.	Nominal Size [mm]	Working L. L. [t]	Dimensions [mm]						Weight app. [kgs]	TWN 0811/1	
				E	D	F	B					
6-8	F08111068	6	1,12	91	13	60	30			0,31	 <p>Fixed Size Master Link Assembly Type TAB 1</p>	
8-8	F08111088	8	2,00	107	16	70	35			0,57		
10-8	F08111108	10	3,15	131	18	85	40			0,95		
13-8	F08111138	13	5,30	159	22	100	50			1,84		
16-8	F08111168	16	8,00	195	26	120	60			3,20		
18-8	F08111188	18	10,00	219	32	140	70			5,40		
22-8	F08111228	22	15,00	260	36	160	80			8,00		
for single leg slings												



Trade Size	Art.-No.	Nominal Size [mm]	Working L. L. $\beta = 0^\circ - 45^\circ$ [t]	Dimensions [mm]						Weight app. [kgs]	TWN 0811/2	
				E	D	F	B					
6-8	F08112068	6	1,60	91	13	60	30			0,42	 <p>Fixed Size Master Link Assembly Type TAB 2</p>	
8-8	F08112088	8	2,80	107	16	70	35			0,78		
10-8	F08112108	10	4,25	131	18	85	40			1,40		
13-8	F08112138	13	7,50	159	22	100	50			2,71		
16-8	F08112168	16	11,20	195	26	120	60			4,80		
18-8	F08112188	18	14,00	219	32	140	70			7,90		
22-8	F08112228	22	21,20	260	36	160	80			11,80		
for double leg slings												

Trade Size	Art.-No.	Nominal Size [mm]	Working L. L. $\beta = 0^\circ - 45^\circ$ [t]	Dimensions [mm]						Weight app. [kgs]	TWN 0811/4	
				E	D	F	B	D ₁				
6-8	F08114068	6	2,36	161	16	70	35	13		1,20	 <p>Fixed Size Master Link Assembly Type TAB 4</p>	
8-8	F08114088	8	4,25	192	18	85	40	16		2,14		
10-8	F08114108	10	6,70	231	22	100	50	18		3,77		
13-8	F08114138	13	11,20	279	26	120	60	22		7,02		
16-8	F08114168	16	17,00	335	32	140	70	26		12,50		
18-8	F08114188	18	21,20	379	36	160	80	32		20,00		
22-8	F08114228	22	31,50	440	40	180	90	36		29,40		
for four leg slings												

Suspension Components

Trade Size	Art.-No.	Crane Hook No. [mm]	Working Load Limit [t]	Dimensions [mm]								Weight app. [kgs]	TWN 0815
				E	D	F	B	D ₁	F ₁	B ₁			
6-8	F08150616	16	1,12	320	18	260	140	13	60	30		1,67	
8-8	F08150816	16	2,00	330	22	260	140	16	70	35		2,60	
10-8	F08151016	16	3,15	330	22	260	140	16	70	35		2,60	
13-8	F08151316	16	5,30	260	26	260	140					3,17	
16-8	F08151616	16	8,00	260	30	260	140					4,30	
18-8	F08151816	16	10,00	370	36	250	140	26	120	60		7,80	
6-8	F08150625	25	1,12	400	20	340	180	13	60	30		2,54	
8-8	F08150825	25	2,00	400	20	340	180	13	60	30		2,54	
10-8	F08151025	25	3,15	410	24	340	180	16	70	35		3,78	
13-8	F08151325	25	5,30	410	28	340	180	16	70	35		5,07	
16-8	F08151625	25	8,00	430	32	340	180	20	90	45		6,95	
18-8	F08151825	25	10,00	440	40	340	180	22	100	50		10,9	
20-8	F08152025	25	12,50	340	40	340	180					9,97	
22-8	F08152225	25	15,00	340	40	340	180					9,97	
6-8	F08150640	40	1,12	490	22	430	220	13	60	30		3,73	
8-8	F08150840	40	2,00	490	22	430	220	13	60	30		3,73	
10-8	F08151040	40	3,15	500	26	430	220	16	70	35		5,33	
13-8	F08151340	40	5,30	500	30	430	220	16	70	35		7,05	
16-8	F08151640	40	8,00	520	34	430	220	20	90	45		9,41	
18-8	F08151840	40	10,00	530	42	430	220	22	100	50		14,5	
20-8	F08152040	40	12,50	430	42	430	220					13,5	
22-8	F08152240	40	15,00	430	42	430	220					13,5	

Trade Size	Art.-No.	Crane Hook No. [mm]	Working Load Limit [t]	Dimensions [mm]								Weight app. [kgs]	TWN 0816
				E	D	F	B	D ₁	F ₁	B ₁			
6-8	F08160616	16	1,60	320	18	260	140	13	60	30		1,88	
8-8	F08160816	16	2,80	330	22	260	140	16	70	35		2,96	
10-8	F08161016	16	4,25	330	26	260	140	16	70	35		3,90	
13-8	F08161316	16	7,50	350	30	260	140	20	90	45		5,75	
16-8	F08161616	16	11,20	370	36	250	140	26	120	60		9,43	
6-8	F08160625	25	1,60	400	22	340	180	13	60	30		3,26	
8-8	F08160825	25	2,80	410	24	340	180	16	70	35		4,14	
10-8	F08161025	25	4,25	410	28	340	180	16	70	35		5,43	
13-8	F08161325	25	7,50	430	32	340	180	20	90	45		7,68	
16-8	F08161625	25	11,20	440	40	340	180	22	100	50		11,9	
18-8	F08161825	25	14,00	440	40	340	180	22	100	50		11,9	
20-8	F08162025	25	17,00	480	45	340	180	32	140	70		18,6	
6-8	F08160640	40	1,60	500	26	430	220	16	70	35		5,70	
8-8	F08160840	40	2,80	500	26	430	220	16	70	35		5,70	
10-8	F08161040	40	4,25	500	30	430	220	16	70	35		7,42	
13-8	F08161340	40	7,50	500	34	430	220	20	70	35		9,88	
16-8	F08161640	40	11,20	530	42	430	220	22	100	50		15,5	
18-8	F08161840	40	14,00	530	42	430	220	22	100	50		15,5	
22-8	F08162240	40	21,20	570	48	430	220	32	140	70		23,7	

Suspension Components

Trade Size	Art.-No.	Crane Hook No. [mm]	Working Load Limit [t]	Dimensions [mm]								Weight app. [kgs]	TWN 0817	
				E	D	F	B	D ₁	F ₁	B ₁				
6-8	F08170616	16	2,36	330	22	260	140	16	70	35			2,96	
8-8	F08170816	16	4,25	330	26	260	140	16	70	35			3,90	
10-8	F08171016	16	6,70	350	30	260	140	20	90	45			5,75	
13-8	F08171316	16	11,20	370	36	250	140	26	120	60			9,43	
16-8	F08171616	16	17,00	370	36	250	140	26	120	60			9,43	
6-8	F08170625	25	2,36	410	24	340	180	16	70	35			4,14	
8-8	F08170825	25	4,25	410	28	340	180	16	70	35			5,43	
10-8	F08171025	25	6,70	430	32	340	180	20	90	45			7,68	
13-8	F08171325	25	11,20	440	40	340	180	22	100	50			11,90	
16-8	F08171625	25	17,00	460	40	340	180	26	120	60			13,20	
20-8	F08172025	25	26,50	590	55	430	220	36	160	80			32,30	
6-8	F08170640	40	2,36	500	26	430	220	16	70	35			5,70	
8-8	F08170840	40	4,25	500	30	430	220	16	70	35			7,42	
10-8	F08171040	40	6,70	520	34	430	220	20	90	45			10,10	
13-8	F08171340	40	11,20	530	42	430	220	22	100	50			15,50	
16-8	F08171640	40	17,00	550	42	430	220	26	120	60			16,80	
18-8	F08171840	40	21,20	570	48	430	220	32	140	70			23,70	
22-8	F08172240	40	31,50	590	55	430	220	36	160	80			32,30	

Oversize master link assy for 3- and 4-leg slings suitable for crane hooks DIN 15401 (16 to, 25 to, 40 to)

Trade Size	Art.-No.	Nominal Size [mm]	Working Load Limit [t]	Dimensions [mm]					Weight app. [kgs]	TWN 0820
				E	F	B				
8-8	F31000	8	2,00	93,5	68	38			0,36	
10-8	F31010	10	3,20	126	95	49			0,86	
13-8	F31020	13	5,00	158,5	120	60			1,60	
16-8	F31030	16	8,00	187	140	80			3,00	
19-8	Z05828	19	11,20	261	203	98			5,58	

Master Link for Single Leg with Pin Coupling

Trade Size	Art.-No.	Nominal Size [mm]	Working Load Limit [t]	Dimensions [mm]					Weight app. [kgs]	TWN 0829
				E	G	A	C	F		
6-8	F30000	6	0,07	44	17	59	45	7,5	0,07	
7-8	F30005	7	1,50	56	17	75	47	9	0,16	
8-8	F30810*	8	2,00	60	18	79	50	10	0,19	
10-8	F30820*	10	3,15	75	22	99	63	12	0,35	
13-8	F30830*	13	5,30	98	28	128	80	15	0,73	
16-8	F30840	16	8,00	110	33	148	98	19	1,38	
18-8	F30850	18	10,00	122	36	165	110	22	1,86	
20-8	F30855	20	12,50	134	45	185	122	26	2,34	
22-8	F30860	22	15,00	145	46	198	132	26	3,16	
26-8	F30870	26	21,20	164	55	225	156	30	5,00	
32-8	F30880	32	31,50	192	65	268	192	37	9,33	

*TOP-Articles (see page 13)

THI-LOK®

Hooks

Trade Size	Art.-No.	Nominal Size [mm]	Working Load Limit [t]	Dimensions [mm]						Weight app. [kgs]	TWN 0798	
				E	D	G	H	C				
6-8	Z07274	6	1,12	106	22,5	28	22	15		0,48	<p>Self-Locking Eye Hook</p>	
7/8-8	Z07275	8	2,00	133	24	35	25	20		0,82		
10-8	Z07276	10	3,15	167	32	45	35	27		1,65		
13-8	Z07277	13	5,30	208	39	54	41	33		3,12		
16-8	Z07278	16	8,00	250	49	67	54	39		5,88		
18/20-8	Z03344 *	18/20	12,50	275	66	78	53	56		7,80		
22-8	Z03329*	22	15,00	317	71	94	72	58		15,00		
*TWN 0836												

Trade Size	Art.-No.	Nominal Size [mm]	Working Load Limit [t]	Dimensions [mm]				Weight app. [kgs]	TWN 0799	
				E	G	H	C			
6-8	Z07279	6	1,12	98	28	22	15	0,57	<p>Self-Locking Clevis Hook</p>	
8-8	Z07280	8	2,00	122	33	25	20	0,93		
10-8	Z07281	10	3,15	150	45	35	27	1,75		
13-8	Z07282	13	5,30	186	54	41	33	3,25		
16-8	Z07296	16	8,00	215	67	54	39	6,20		
18/20-8	Z00503*	18/20	12,50	238	78	54	48	8,00		
*TWN 0837										

Trade Size	Art.-No.	Nominal Size [mm]	Working Load Limit [t]	Dimensions [mm]				Weight app. [kgs]	TWN 1340/1
				E	G	H	C		
6-8	F336010	6	1,12	75	24	20	17	0,36	<p>Sling Hook with Clevis and Safety Latch</p>
8-8	F336110	8	2,00	92	30	25	22	0,75	
10-8	F336210	10	3,15	113	37	32	28	1,40	
13-8	F336310	13	5,30	133	42	41	35	2,50	
16-8	F336410	16	8,00	162	51	50	41	4,40	



Hooks

Trade Size	Art.-No.	Nominal Size [mm]	Working Load Limit [t]	Dimensions [mm]						Weight app. [kgs]	TWN 0835/1
				E	G	H	C				
18-8	F33651	18	10,00	195	60	52	50			7,59	 <p>Sling Hook with Clevis and Safety Latch</p>
20-8	F33656	20	12,50	220	65	58	55			9,68	
22-8	F33661	22	15,00	244	75	64	61			10,62	



Sling Hook with Clevis
and Safety Latch

Trade Size	Art.-No.	Nominal Size [mm]	Working Load Limit [t]	Dimensions [mm]						Weight app. [kgs]	TWN 0854
				E	G	H	C	F	B		
0,75-8M	F32103	-	0,75	113,5	19	14	13	25	30	0,36	 <p>Swivel Hook with Safety Latch</p>
6-8	F32100	6	1,12	113	18	20	14	25	30	0,38	
8-8	F32110	8	2,00	155	21	25	19	42	44	1,00	
10-8	F32120	10	3,15	162	23	30	21	42	44	1,20	
13-8	F32130	13	5,30	190	32	33	28	43	51	2,08	
16-8	F32140	16	8,00	247	40	43	35	61	64	4,45	

Also applicable for wire ropes and thimbles;
Swivel Hook are only for stripping and not built for twisting purposes under load.

TWN 0858/1

Both forces must correspond to min. 300 kg or 10% of working load limit of the hook, depending on which value is larger.
Force f₂ should not be larger than 20 kN.

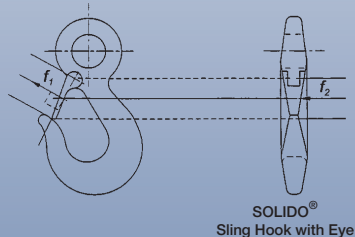



Hooks

Trade Size	Art.-No.	Nominal Size [mm]	Working Load Limit [t]	Dimensions [mm]						Weight app. [kgs]	TWN 0855
				E	D	G	H	C			
36-8	Z04079	36	40,00	388	72	109	103	78		31,50	
40-8	Z04083	40	50,00	442	84	124	116	89		46,00	
45-8	Z04080	45	63,00	494	90	138	130	99		63,00	
50-8	Z04081	50	80,00	610	102	155	145	110		80,00	



Sling Hook with Eye

Trade Size	Art.-No.	Nominal Size [mm]	Working Load Limit [t]	Dimensions [mm]						Weight app. [kgs]	TWN 0855/1
				E	D	G	H	C			
36-8	Z06159	36	40,00	388	72	109	103	78		32,30	
40-8	Z06160	40	50,00	442	84	124	116	89		47,00	
45-8	Z06161	45	63,00	494	90	138	130	99		64,40	
50-8	Z06162	50	80,00	610	102	155	145	110		81,90	



Sling Hook with Eye and Safety Latch

Trade Size	Art.-No.	Nominal Size [mm]	Working Load Limit [t]	Dimensions [mm]						Weight app. [kgs]	TWN 0856
				E	D	G	H	C			
6-8	Z00456	6	1,12	95	13	50	24	20		0,53	
8-8	F32360	8	2,00	125	18	66	33	27		0,93	
10-8	F32370	10	3,15	146	20	76	35	32		1,66	
13-8	F32380	13	5,30	175	26	89	41	38		3,15	
16-8	F32390	16	8,00	205	32	102	48	45		5,41	
18/20-8	F32400	18/20	12,50	235	40	114	54	51		7,50	
22-8*	Z00457	22	15,00	265	47	127	70	65		11,40	
26-8*	Z00458	26	21,20	305	52	136	80	72		13,60	
32-8*	Z00459	32	31,50	327	60	152	93	83		28,00	
*free-form forged											



Foundry or Container Eye Hook



Hooks

New

Trade Size	Art.-No.	Nominal Size [mm]	Working Load Limit [t]	Dimensions [mm]						Weight app. [kgs]
				E	D ₁	D ₂	G	H	C	
6-8	F32901	6	1,12	91	21	11	23	17	16	0,31
8-8	F32911	8	2,00	120	28	14	30	24	22	0,80
10-8	F32921	10	3,15	152	36	18	38	29	28	1,69
13-8	F32931	13	5,30	180	42	21	42	41	36	2,82
16-8	F32941	16	8,00	221	54	27	52	45	43	5,05
18/20-8	F32951	18/20	12,50	270	62	30	65	58	55	8,70
22-8	F32971	22	15,00	300	70	32	75	64	61	11,50
26-8	F32981	26	21,20	335	78	39	78	70	68	17,20
32-8	F32991	32	31,50	410	96	48	95	83	80	30,20

TWN 0858/1



GK

SOLIDO®
Sling Hook with Eye
and Safety Latch

Trade Size	Art.-No.	Nominal Size [mm]	Working Load Limit [t]	Dimensions [mm]				Weight app. [kgs]
				E	G	H	C	
8-8	F33310	8	2,00	110	66	33	27	1,00
10-8	F33320	10	3,15	133	76	35	32	1,61
13-8	F33330	13	5,30	159	89	41	38	3,40
16-8	F33340	16	8,00	189	102	48	45	5,50
22-8	F33360	22	15,00	244	124	60	56	12,00

TWN 0859



Foundry Hook
with Clevis

Trade Size	Art.-No.	Working Load Limit [t]	Dimensions [mm]						Weight app. [kgs]
			E	G	R	D	B		
0,15	F18130	0,15	80	28	14	10	16	0,12	
0,25	F18160	0,25	100	36	18	12	20	0,21	
0,40	F18180	0,40	130	46	23	16	25	0,48	
0,80	F18200	0,80	160	56	28	20	30	0,91	
1,12 (6-8)	F18220	1,12	180	64	32	22	32	1,20	
1,50 (7-8)	F18230	1,50	200	70	35	26	35	1,90	
2,00 (8-8)	F18250	2,00	230	80	40	32	40	3,40	
3,15 (10-8)	F18260	3,15	260	90	45	36	45	4,80	
4,00	F18280	4,00	300	104	52	40	52	6,80	
4,50	F18290	4,50	350	122	61	45	60	10,00	
5,30 (13-8)	F18300	5,30	400	140	70	51	68	14,60	
6,00	F18310	6,00	450	158	79	57	75	20,50	
8,00 (16-8)	F18320	8,00	500	160	80	63	80	27,40	
10,00 (18-8)	F18330	10,00	550	166	83	72	85	39,00	

TWN 0860





S-Hook

further types on request



Hooks

Trade Size	Art.-No.	Nominal Size [mm]	Working Load Limit [t]	Dimensions [mm]								Weight app. [kgs]	TWN 0868
				B	A	D ₁	D ₂	G	H	C			
13-8	F32608	13	5,30	174	226	28	20	49	57	60	3,30	 <p>Pipe Transport Hook</p>	
22-8	F32641	22	15,00	274	345	44	30	80	90	95	15,12		

Trade Size	Art.-No.	Nominal Size [mm]	Working Load Limit [t]	Dimensions [mm]								Weight app. [kgs]	TWN 0872
				E	E ₁	B	C	D	F	H			
6-8	F35500	6	1,60	150	180	90	60	15	60	20	2,50	 <p>Plate Hook for Basket Chain</p>	
8-8	F35501	8	2,80	157	197	90	80	20	70	25	4,00		
10-8	F35502	10	4,25	230	278	140	90	22	80	30	8,50		
13-8	F35503	13	7,50	241	312	145	100	26	90	35	11,00		
16-8	F35504	16	11,20	270	354	155	120	32	110	45	16,80		
18/20-8	F35505	18/20	17,00	322	398	175	120	40	120	62	30,00		
22-8	F35506	22	21,20	364	456	205	130	44	140	65	40,30		
26-8	F35507	26	30,00	409	501	230	140	52	160	75	61,50		
32-8	F35508	32	45,00	457	557	255	140	64	180	85	85,50		
* per pair - use only at inclination $\beta = 15-30^\circ$. Further dimensions and free-hand forgings on request													

Trade Size	Art.-No.	Nominal Size [mm]	Working Load Limit [t]*	Dimensions [mm]								Weight app. [kgs]	TWN 0873
				E	C	D	F	H					
6-8	F35600	6	1,60	90	60	32	60	20			2,40	 <p>Plate Hook for Basket Chain</p>	
8-8	F35601	8	2,80	90	80	38	70	25			3,50		
10-8	F35602	10	4,25	140	90	50	80	30			8,00		
13-8	F35603	13	7,50	145	100	62	90	35			10,50		
16-8	F35604	16	11,20	155	120	76	110	45			16,00		
18/20-8	F35605	18/20	17,00	175	120	92	120	62			25,00		
22-8	F35606	22	21,20	205	130	95	140	65			34,00		
26-8	F35607	26	30,00	230	140	115	160	75			50,00		
32-8	F35608	32	45,00	255	140	135	180	85			69,00		
* per pair - use only at inclination $\beta = 15-30^\circ$. Further dimensions and free-hand forgings on request													



Hooks

Trade Size	Art.-No.	Nominal Size [mm]	Working Load Limit [t]	Dimensions [mm]								Weight app. [kgs]	TWN 0887
				E	G	H	C	D	F	B			
0,35	F32160	-	0,35	98,5	14	14	14	9	20	16	0,24	 <p>Swivel Hook</p>	



Trade Size	Art.-No.	Nominal Size [mm]	Working Load Limit [t]	Dimensions [mm]								Weight app. [kgs]	TWN 0889
				E	G	H	C						
0,50	F33439	6	0,50	137	19	13	12					0,55	 <p>Lifting Hook for Engines</p>

Shortening Components

Trade Size	Art.-No.	Nominal Size [mm]	Working Load Limit [t]	Dimensions [mm]						Weight app. [kgs]	TWN 0827
				E	G	L	B				
8-8	F33200	8	2,00	61	9	101	61			0,53	
10-8	F33210	10	3,15	73	12	125	75			0,97	
13-8	F33220	13	5,30	95	15	160	95			2,18	
16-8	F33230	16	8,00	112	18	188	120			3,40	
20-8	F33245	20	12,50	148	22,5	242	141			7,30	
with extra wide chain bed											

Trade Size	Art.-No.	Nominal Size [mm]	Working Load Limit [t]	Dimensions [mm]						Weight app. [kgs]	TWN 0827/1
				E	G	L	B				
8-8	F33201	8	2,00	61	9	101	61			0,54	
10-8	F33211	10	3,15	73	12	125	75			0,99	
13-8	F33221	13	5,30	95	15	160	95			2,18	
16-8	F33231	16	8,00	112	18	188	120			3,45	
20-8	F33246	20	12,50	148	22,5	242	141			7,35	
with extra wide chain bed											

Trade Size	Art.-No.	Nominal Size [mm]	Working Load Limit [t]	Dimensions [mm]						Weight app. [kgs]	TWN 0851
				E	L	M					
6-8	F34910	6	1,12	54	81	32				0,21	
7-8	F34920	7	1,50	74	108	43				0,42	
8-8	F34925	8	2,00	80	115	46				0,56	
10-8	F34930	10	3,15	90	134	56				0,94	
13-8	F34940	13	5,30	117	175	72				2,10	
16-8	F34950	16	8,00	144	214	86				3,57	
18-8	F34960	18	10,00	162	241	98				5,40	
20-8	F34970	20	12,50	158	241	98				5,40	
22-8	F34980	22	15,00	198	295	118				9,00	
26-8	F34985	26	21,20	195	309	130				12,00	
32-8	F34990	32	31,50	240	381	160				19,00	
with extra wide chain bed											



Shortening Components

Trade Size	Art.-No.	Nominal Size [mm]	Working Load Limit [t]	Dimensions [mm]					Weight app. [kgs]	TWN 0896
				E	E ₁	E ₂	B-Link			
6-8	F0896068	6	1,12	137	31	60	ø 10 x	46 x 23	0,32	 <p>Shortening Device for fixed size Master Link</p>
8-8	F0896088	8	2,00	176	38	78	ø 13 x	60 x 30	0,68	
10-8	F0896108	10	3,15	215	46	99	ø 16 x	70 x 35	1,41	
13-8	F0896138	13	5,30	270	59	126	ø 18 x	85 x 40	2,60	
16-8	F0896168	16	8,00	326	76	150	ø 22 x	100 x 50	4,60	
18-8	F0896188	18	10,00	347	79	168	ø 22 x	100 x 50	6,30	
22-8	F0896228	22	15,00	450	100	210	ø 32 x	140 x 70	12,00	



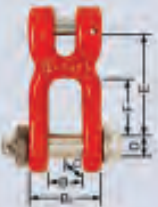

Shackles

Trade Size	Art.-No.	Nominal Size [mm]	Working Load Limit [t]	Dimensions [mm]							Weight app. [kgs]	TWN 0861
				E	D	C	F	B ₁	B ₂			
10-8	F30601	10	3,15	64	16	32	36	21	47	0,61	 <p>Special Chain Coupling Shackle</p>	
13-8	F30611	13	5,30	82,5	20	40	49	27	61	1,24		
16-8	F30621	16	8,00	99	24	48	56	33	75	2,10		
18-8	F30631	18	10,00	115	30	60	63	42	100	3,93		

Trade Size	Art.-No.	Nominal Size [mm]	Working Load Limit [t]	Dimensions [mm]						Weight app. [kgs]	TWN 0862
				E	D	C	F	B ₁	B ₂		
10-8	F30600	10	3,15	64	16	32	36	21	47	0,67	 <p>Chain Coupling Bolt Shackle</p>
13-8	F30610	13	5,30	82,5	20	40	49	27	61	1,37	
16-8	F30620	16	8,00	99	24	48	56	33	75	2,28	
18-8	F30630	18	10,00	115	30	60	63	42	100	4,37	

Shackles

Trade Size	Art.-No.	Nominal Size	Nominal Size	Working Load Limit [t]	Dimensions [mm]						Weight app. [kgs]	TWN 0870
		[mm]	[DIN 82101]		E	D ₁	D ₂	C	B ₁	B ₂		
10-8	F30311	10	1	3,15	49	15	16	32	21	47	0,35	 <p>Special Shackle</p>
13-8	F30321	13	1,6	5,30	61	19	20	40	27	61	0,74	
16-8	F30331	16	2,5	8,00	73	23	24	48	33	75	1,30	
18/20-8	F30341	18/20	4	12,50	91	29	30	60	42	96	2,60	
22-8	F30351	22	5	15,00	111	33	36	72	47	107	4,00	
26-8	F30361	26	6	21,20	120	37	39	78	53	121	5,70	
28-8	F30371	28	8	25,00	140	41	45	90	60	136	10,00	
32-8	F30381	32	10	31,50	147	45	48	96	66	150	10,50	
36-8	F30391	36	12	40,00	158	50	52	104	73	167	13,90	
40-8	F30401	40	16	50,00	185	55	60	120	81	185	20,50	
45-8	F30411	45	20	63,00	211	61	68	136	90	206	26,60	

Trade Size	Art.-No.	Nominal Size	Nominal Size	Working Load Limit [t]	Dimensions [mm]						Weight app. [kgs]	TWN 0871
		[mm]	[DIN 82101]		E	D ₁	D ₂	C	B ₁	B ₂		
6-8	Z04147*	6	0,4	1,12	30	8	10	20	14	30	0,10	 <p>Bolt Shackle Type C</p>
8-8	Z04145	8	0,6	2,00	36	10	12	24	17	37	0,20	
10-8	F30310	10	1	3,15	49	15	16	32	21	47	0,45	
13-8	F30320	13	1,6	5,30	61	19	20	40	27	61	0,84	
16-8	F30330	16	2,5	8,00	73	23	24	48	33	75	1,40	
18/20-8	F30340	18/20	4	12,50	91	29	30	60	42	96	3,10	
22-8	F30350	22	5	15,00	111	33	36	72	47	107	4,50	
26-8	F30360	26	6	21,20	120	37	39	78	53	121	6,30	
28-8	F30370	28	8	25,00	140	41	45	90	60	136	10,10	
32-8	F30380	32	10	31,50	147	45	48	96	66	150	12,30	
36-8	F30390	36	12	40,00	158	50	52	104	73	167	15,60	
40-8	F30400	40	16	50,00	185	55	60	120	81	185	22,20	
45-8	F30410	45	20	63,00	211	61	68	136	90	206	26,30	

* Finish: electro galvanized, nut welded on

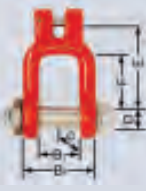
Trade Size	Art.-No.	Nominal Size	Working Load Limit [t]	Dimensions [mm]						Weight app. [kgs]	TWN 0897
		[mm]		E	D	C	F	B ₁	B ₂		
6-8	F30586	6	1,12	70	20	39	46	35	65	0,47	 <p>Special Coupling Shackle</p>
8-8	F30596	8	2,00	70	20	40	46	35	65	0,54	



Shackles

Trade Size DIN 82016	Art.-No.	Working Load Limit [t]	Dimensions [mm]								Weight app. [kgs]	TWN 0898
			E	D	H	C	B ₁	B ₂	A			
10	F38355	35	166	48	60	96	66	150	186	11,86	 <p>Cargo Shackle</p>	
20	F38370	70	231	68	85	136	90	206	256	31,46		





Trade Size DIN 82016	Art.-No.	Working Load Limit [t]	Dimensions [mm]								Weight app. [kgs]	TWN 0898/1
			E	D	H	C	B ₁	B ₂	A			
10	F38357	35	171	38	60	96	48	150	186	11,62	 <p>Cargo Shackle with bush</p>	



Chain Tensioners

Trade Size	Art.-No.	Nominal Size [mm]	norm. straight load (S_{T1}) [daN] min.	tensioner under straight load [kN] max.	Dimensions [mm]			Weight app. [kgs]	TWN 1450
					E_{max}	E_{min}	stroke		
8-8	F34179	8	1800	40	345	270	75	2,10	 <p>Chain Tensioner acc. to DIN EN 12195-3</p>
10-8	F34199	10	2200	63	375	275	100	2,70	
13-8	F34189	13	2600	100	460	340	120	4,00	
can be also used in slings									

Trade Size	Art.-No.	Nominal Size [mm]	norm. straight load (S_{T1}) [daN] min.	tensioner under straight load [kN] max.	Dimensions [mm]			Weight app. [kgs]	TWN 1451
					E_{max}	E_{min}	stroke		
8-8	F34175	8	1800	40	345	270	75	2,50	 <p>Chain Tensioner acc. to DIN EN 12195-3</p>
10-8	F34195	10	2200	63	375	275	100	3,50	
13-8	F34185	13	2600	100	460	340	120	5,00	
can be also used in slings									

Trade Size	Art.-No.	Nominal Size [mm]	norm. straight load (S_{T1}) [daN] min.	tensioner under straight load [kN] max.	Dimensions [mm]			Weight app. [kgs]	TWN 1452
					E_{max}	E_{min}	stroke		
13-8	F341871	13	2600	100	675	445	230	7,20	 <p>Chain Tensioner acc. to DIN EN 12195-3</p>
16-8	F34197	16	3100	160	835	555	280	11,80	
can be also used in slings									



Special Sling Components

Trade Size	Art.-No.	Nominal Size [mm]	Working Load Limit [t]	Dimensions [mm]								Weight app. [kgs]	TWN 0812	
				E	D ₁	D ₂	B							
6-8	F31700	6	1,12	31	17	39	8					0,10	 <p>Ringshackle</p>	
8-8	F31710	8	2,00	37	21	50	11					0,20		
10-8	F31720	10	3,15	46	26	62	14					0,40		
13-8	F31730	13	5,30	59	33	79	18					0,87		
16-8	F31740	16	8,00	75	42	99	22					1,60		
18-8	F31750	18	10,00	79	47	111	25					2,50		
22-8	F31760	22	15,00	100	55	136	31					3,80		



Trade Size	Art.-No.	Working Load Limit [t]	Dimensions [mm]				Weight app. [kgs]	TWN 0845
			E	F	B			
6-8	F34000	1,12	108	27	30		0,33	 <p>Swivel</p>
8-8	F34010	2,00	168	44	44		1,33	
10-8	F34020	3,15	168	44	44		1,33	
13-8	F34030	5,30	184	46	51		2,10	
16-8	F34040	8,00	252	66	64		4,45	



Special Sling Components

Trade Size	Art.-No.	Nominal Size [mm]	Working Load Limit [t]	Dimensions [mm]						Weight app. [kgs]	TWN 0869
				E	F	B	A				
13-8	F31380	13	5,30	141	57	65	125			1,80	 <p>Skip Suspension Link with Pin Coupling and forged Safety Latch</p>
16-8	F31385	16	8,00	148	57	65	127			2,60	

Trade Size	Working Limit [t]		Dimensions [mm]						Weight app. [kgs]	TWN 0875	
	from	to									
1	3,15	5,30								4,02	 <p>Reduction Assembly</p>
2	6,30	10,00								17,46	
3	12,50	20,00									

Please indicate the dimension of the crane hook or crane hook No.

Special Sling Components

Trade Size	Art.-No.	Nominal Size [mm]	Dimensions [mm]								Weight app. [kgs]
			E	A	D ₁	D ₂	B	C	F		
6-8	F48300	6	42	100	14	18	8	11	10	0,40	
8-8	F48303	8	56	130	18	22	10	15	12	0,80	
10-8	F48306	10	70	160	22	28	13	19	15	1,50	
13-8	F48309	13	91	210	28	40	16	25	20	3,40	
16-8	F48312	16	110	260	36	42	20	30	25	5,60	
18-8	F48313	18	130	290	40	54	23	34	25	8,40	
20-8	F48322	20	130	300	42	54	25	35	30	10,90	
22-8	F48315	22	140	330	46	56	28	39	35	15,20	
26-8	F48319	26	170	390	54	66	33	46	40	24,70	
32-8	F48321	32	210	480	68	80	40	54	50	47,40	

Trade Size	Working Load Limit [t] max.		Breaking Force [kN] min.
	0° < β ≤ 45°	45° < β ≤ 60°	
6-8	1,60	1,12	71
8-8	2,80	2,00	124
10-8	4,25	3,15	200
13-8	7,50	5,30	340
16-8	11,20	8,00	490
18-8	14,00	10,00	628
20-8	17,00	12,50	785
22-8	21,20	15,00	950
26-8	30,00	21,20	1.300
32-8	45,00	31,50	1.960

TWN 0882





F = Thickness





Balancer

Special Sling Components

Trade Size	Art.-No.	Nominal Size [mm]	Working Load Limit [t]	Dimensions [mm]							Weight app. [kgs]	TWN 0892
				E	d	D ₁	D ₂	D ₃	F			
10-8	F34250	10	3,15	168	17	20	17	40	25		0,82	 <p>Key Hook</p>

Trade Size	Art.-No.	Nominal Size [mm]	Working Load Limit [t]	Dimensions [mm]							Weight app. [kgs]	TWN 0893	
				E	D	F	B	G	H	C			
6-8	F09804	6	1,12	307	18	130	70	24	20	17	1,73	 <p>Isolation Assembly</p>	
8-8	F08912	8	2,00	329	18	130	70	30	25	22	2,16		
10-8	F08898	10	3,15	371	18	130	70	37	32	28	3,25		
13-8	F08899	13	5,30	425	22	160	90	42	41	35	5,27		

Isolates a power flow rate till max. 1.000 Volt.

Trade Size	Art.-No.	Nominal Size [mm]	Working Load Limit [t]	Dimensions [mm]					Weight app. [kgs]	TWN 0894	
				L							
10-8	F08811	10	1,60	405,5					1,70	  <p>Connecting Element Line 024 10810-0-011</p> <p>T-Handle Chain</p>	
10-8	F08812	10	1,60	675,5					2,30		







Special Sling Components

Trade Size	Art.-No.	Nominal Size [mm]	Working Load Limit [t]	Dimensions [mm]						Weight app. [kgs]	TWN 0895
				E	D	F	G	A			
13-8	F30975	13	5,30	79	36	28	28	82		1,20	 <p style="text-align: right;">GK</p> <p style="text-align: center;">Swivel Adapter</p>
Working Load Limit for vertical load only.											

Art.-No. Single Leg	Art.-No. Multi Leg	Dimensions Ø [mm]	Weight app. [kgs]	TWN 0940
F08040 ¹⁾	F08044 ¹⁾	70	0,10	
F08042 ²⁾	F08046 ²⁾	70	0,11	
1) without welded ring				
2) with welded ring				



Special Sling Components

<p>Chain Card File</p>	<p>TWN 0944</p>
<p>To file the regular tests of chains according to standard DIN.</p>	
<p>Art. No. Z04575</p>	
<p>Assembly Set</p>	<p>TWN 0945</p>
<p>Consisting of 6 punches in a plastic holder to separate chains from components. The complete set covers all sizes for the use with the THIELE Sling-Assembly-System.</p>	
<p>Art. No. Z03303</p>	
<p>Chain Gauge Set</p>	<p>TWN 0946</p>
<p>For regular wear inspection of chain sizes 6-8 to 32-8 on site.</p>	
<p>Art. No. F48856</p>	
<p>Tensioning Tag for Lashing Chains acc. to EN 12195-3</p>	<p>TWN 1402</p>
<p>Art. No. Z07264</p>	



Lashing Chains

Lashing Chain with Tensioner (according to DIN EN 12195-3)

TWN 1400



Standard length L = 3500 mm, with opened tensioner, not shortened. All lengths available upon request. The adjustment will be reached by the shortening device and the tensioner.

GK

Trade Size	Art.-No.	Nominal Size [mm]	Maximum Lashing Force under Straight Load	Weight
			[kN]	app. [kgs]
8-8	F34171	8	40	8,50
10-8	F34172	10	63	12,50
13-8	F34173	13	100	21,00
16-8	F34174	16	160	37,70

Lashing Chain with Ratchet (according to DIN EN 12195-3)

TWN 1401



Standard length L = 3500 mm, with opened tensioner, not shortened. All lengths available upon request. The adjustment will be reached by the shortening device and the tensioner.

Trade Size	Art.-No.	Nominal Size [mm]	Maximum Lashing Force under Straight Load	Weight
			[kN]	app. [kgs]
8-8	F34171R	8	40	8,50
10-8	F34172R	10	63	12,50
13-8	F34173R	13	100	21,00

Spare Parts and Accessories

Trade Size	Art.-No.	Packing Units	Weight app. [kgs]	TWN 0904/0
6-8	F48694	1 set	0,01	
8-8	F48352	1 set	0,01	
10-8	F48355	1 set	0,03	
13-8	F48358	1 set	0,07	
16-8	F48361	1 set	0,11	
18-8	F48364	1 set	0,20	
20-8	F48369	1 set	0,26	
22-8	F48367	1 set	0,31	
26-8	F48373	1 set	0,50	
32-8	F48371	1 set	0,91	



Load Pin
for Clevis Type Hooks

Trade Size	Art.-No.	Packing Units	Weight app. [kgs]	TWN 0905 / 0906
10-8	F48036	1 set	0,07	
13-8	F48039	1 set	0,14	
16-8	F48042	1 set	0,25	
18/20-8	F48045	1 set	0,44	
22-8	F48048	1 set	0,78	
26-8	F48051	1 set	1,05	
28-8	F48054	1 set	1,60	
32-8	F48057	1 set	2,02	
36-8	F48060	1 set	2,60	
40-8	F48063	1 set	3,89	



Load-Spirol Pins for Chain
Coupling Shackles and
Chain Shackles



(TWN 0861, TWN 0870)

Trade Size	Art.-No.	Art.-No.	Packing Units	Weight app. [kgs]	TWN 0920 - 0922
	TWN 0854	TWN 0855/1			
6-8	F48420	-	1 set	0,02	
8-8	F48423	-	1 set	0,03	
10-8	F48426	-	1 set	0,04	
13-8	F48429	-	1 set	0,11	
16-8	F48469	-	1 set	0,19	
18/20-8	-	-	1 set	-	
22-8	-	-	1 set	-	
26-8	-	-	1 set	-	
32-8	-	-	1 set	-	
36-8	-	Z06163	1 set	0,80	
40-8	-	Z06164	1 set	1,00	
45-8	-	Z06165	1 set	1,40	
50-8	-	Z06166	1 set	1,90	



Latch Set for Eye Hooks and
Swivel Hooks



(TWN 0854 / 0855/1)

Spare Parts and Accessories

Trade Size	Art.-No.	Packing Units	Weight app. [kgs]	TWN 0929/0
6-8	F48601*	1 set	0,01	 <p>Pin Set for THI-LOK'S</p>  <p>(TWN 0829)</p>
6-8	F48602**	1 set	0,01	
7-8	F48501	1 set	0,01	
8-8	F48604	1 set	0,02	
10-8	F48607	1 set	0,04	
13-8	F48610	1 set	0,07	
16-8	F48613	1 set	0,14	
18-8	F48615	1 set	0,19	
20-8	F48617	1 set	0,31	
22-8	F48619	1 set	0,32	
26-8	F48622	1 set	0,53	
32-8	F48625	1 set	0,95	

* old design until 30.04.08 / ** new design from 01.05.08



Trade Size	Art.-No.	Packing Units	Weight app. [kgs]	TWN 0930-0932
10-8	F30451	1 set	0,13	 <p>Pin set for chain couplings Bolt Shackle and C-Shackle</p>  <p>(TWN 0862, TWN 0871)</p>
13-8	F30461	1 set	0,25	
16-8	F30471	1 set	0,36	
18/20-8	F30481	1 set	0,97	
22-8	F30491	1 set	1,31	
26-8	F30501	1 set	1,99	
28-8	F30511	1 set	2,89	
32-8	F30521	1 set	3,69	
36-8	F30531	1 set	4,48	
40-8	F30541	1 set	6,65	
	F30551	1 set	8,20	

Trade Size	Art.-No.	Packing Units	Weight app. [kgs]	TWN 0950-0952
8-8	F48330	1 set	0,01	 <p>Repair Kit for lockable Grab Hooks</p>  <p>(TWN 0827/1)</p>
10-8	F48328	1 set	0,02	
13-8	F48329	1 set	0,03	
16-8	F48339	1 set	0,05	
20-8	F48345	1 set	0,10	



Spare Parts and Accessories

Trade Size	Art.-No.	Packing Units	Weight app. [kgs]	TWN 0962
13/16-8	F31404 (new)*	1 set	0,28	 <p>Spare Set for Skip Suspension Links</p>  <p>(TWN 0869)</p>

Trade Size	Art.-No.	Packing Units	Weight app. [kgs]	TWN 0967/0
6-8	F333700	1 set	0,01	 <p>Spare Pin for Clevis Self Locking Hooks</p>  <p>(TWN 0799)</p>
8-8	F333711	1 set	0,02	
10-8	F333721	1 set	0,03	
13-8	F333730	1 set	0,06	
16-8	F333741	1 set	0,17	
18/20-8	Z03481*	1 set	0,22	
*TWN 0837				

Spare Parts and Accessories

Trade Size	Art.-No.	Packing Units	Weight app. [kgs]	TWN 0967/1
6-8	F329090	1 set	0,02	 <p>Trigger Set for Self Locking Hooks</p>  <p>(TWN 0798, TWN 0799)</p>
8-8	F329190	1 set	0,03	
10-8	F329290	1 set	0,04	
13-8	F329390	1 set	0,06	
16-8	F329490	1 set	0,11	
18/20-8	Z03451*	1 set	0,27	
22-8	Z03452*	1 set	0,33	
*TWN 0836/0837				



Trade Size	Art.-No.	Packing Units	Weight app. [kgs]	TWN 1908/5 *TWN 0908/0
6-8	F48730	1 set	0,02	 <p>Spare Parts for Sling Hooks</p>  <p>(TWN 0835/1, TWN 0858/1)</p>
8-8	F48732	1 set	0,03	
10-8	F48734	1 set	0,13	
13-8	F48736	1 set	0,26	
16-8	F48738	1 set	0,31	
18-8*	F48585	1 set	0,56	
20-8	F48742	1 set	0,75	
22-8*	F48744	1 set	0,98	
26-8	F48746	1 set	1,43	
32-8	F48747	1 set	2,43	

Forged Safety Latch



Chain and Wire Rope Cutter TWN 0941

Function and Design

The THIELE-Universal-Chain and Wire Rope Cutting Machine is a mobile unit, which allows easy cutting-mounting and servicing of chain and wire rope slings.

The THIELE-Universal Chain and Wire Rope Cutting Machine can be moved easily and safely due to light steerable wheels and fulfil the latest Accident Prevention regulations. The compact hydraulic unit is controlled by a foot switch, allows the cutting of chain or wire rope due to fast interchangeable blades. The cutting machine has a lockable tool compartment and a large work top.



Drive:	Electro-Hydraulic with 700 kN Shearing Force
Artikel-No.:	F48950
Voltage:	220/380 V 3 Ph. 50 Hz, 220 V 1 Ph. 50 Hz or 440 V 3 Ph. – 60 Hz, Export
Dimensions	
(ca.) L x W x H:	1200 x 700 x 1300 mm (with closed protection cover)
Working Height:	900 mm
Weight::	270 kg

Cutting Range

Chains according to EN 817-7, EN 818-2-8, 818-2-8, ASTM 391, ASTM 973 – Grade 80 / 100 and DIN 22 252 up to 26 mm diameter, wire rope up to 30 mm diameter and with a strength of 1600 N/mm², higher strengths and larger diameters on requested.

Accessories

- 1 set of tools for changing the blades,
- 2 sets of blades one for chains and one for wire rope

The Chain and Wire Rope Cutting Machine has one of the above mentioned voltages. The hydraulic tank is filled with hydraulic oil. The oil level is to be checked regularly and refilled if necessary.

Special Accessories

- 1. Holding Clamp:** The holding clamp keeps the wire rope at a right angle to the cutting direction.
- 2. Stroke Adjustment:** With the stroke adjustment the cutting stroke can be adjusted from 0 mm to 50 mm. The advantage is that a no load operation is avoided when cutting small diameters (working time is saved).
- 3. Wire Rope Clamp:** The wire rope clamp prevents the wire rope from falling onto the ground after it has been cut, which always has to be picked up (easier to work with and saves valuable working time).

THIELE key design

Standard Sling Chains (mounted)¹⁾



TG A2/10-8 T 870 TWN0856

GK

TG A 2 / 10-8 T 2000 TWN0835/1 nsw RAL3003

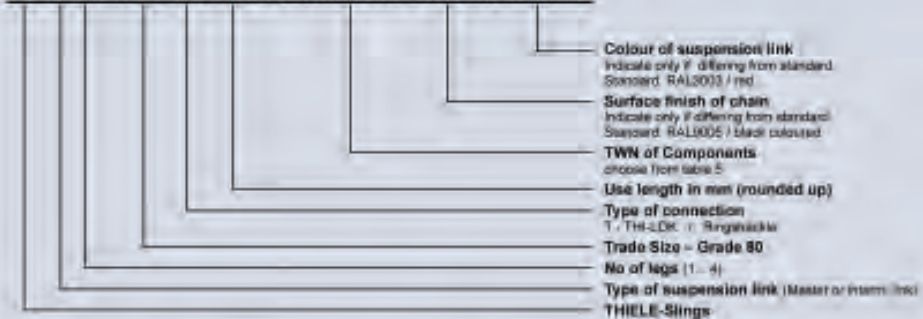

¹⁾ Please, always indicate the THIELE key design in case of order.

Example (Pic. in the middle): TG A 2 / 10-8 T 870 TWN0856 (without suffix because of red (RAL 3003) black coloured end suspension link (RAL 3003 red))

Complement to THIELE key design for slings with shortening components:

(Key design as above)	+ 1 VK	shortening claw with pin coupling (TWN0851)
-	+ 1 VE/VK	shortening device (TWN0895) plus shortening claws (TWN0851)
-	+ 1 VH	shortening hook (TWN0827)
-	+ 1 VE/VH	shortening device (TWN0895) plus shortening hook (TWN0827)
-	+ 1 VHS	shortening with pin coupling (TWN0827/1)
-	+ 1 VEA/VHS	shortening device (TWN0895) plus shortening hook with pin coupling (TWN0827/1)
		No. of shortenings (only 2 legs off)



THIELE key design for endless chains

Table of available components for standard sling chains (mounted)

Master Link ²⁾	... TWN0807	Intermediate Link ²⁾	... TWN0795
Master Link for single leg w. Pin Coupling	... TWN0820		
Suspension Shackle with Pin Coupling and forged Safety Pin for Skips			... TWN0869
Chain Coupling Bolt Shackle	... TWN0862	Special Chain Coupling Shackle	... TWN0861
Special Coupling Shackle	... TWN0897	Foundry or Container Hook with Pin Coupling	... TWN0859
Foundry Hook Cont. or Cont. Eye Hook ²⁾	... TWN0856	Ringshackle	... TWN0812
Bolt Shackle ²⁾	... TWN0871	Sling Hook with Pin Coupling	... TWN0835
Sling Hook w. Pin Coupl. and Safety Latch	... TWN0835/1	Eye Slip Hook with Safety Latch ²⁾	... TWN0858/1
Self-locking Eye Hook ²⁾	... TWN0798	Self-locking clevis Hook	... TWN0799
Special Chain Shackle ²⁾	... TWN0870	THI-LOK	... TWN0829
Shortening Hook with Pin Coupling	... TWN0827	Swivel Hook with Latch ²⁾	... TWN0854
Shortening Hook w. Pin Coupling a. Safety Latch	... TWN0827/1	Chain Swivel ²⁾	... TWN0845

²⁾At complete slings always with connection THI-LOK.

Form K11 **Form K12** **Form K22**

TK K1 2 / 10-8 T 1000 nsw RAL3003

- Colour of components**
indicate only if differing from standard.
Standard: RAL 3003 / red coloured
- Surface finish of chain**
indicate only if differing from standard.
Standard: RAL 9006 / black coloured
- Reach in mm (±%) circumference)**
- Type of connection**
1 - THI-LOK (R - Ringshackle
- Trade Size = Grade 80**
- Execution**
1 - simple (see left pic. above)
2 - with throughout suspension link
3 - with built-in suspension link
- No. of rings (1 or 2)**
- THIELE-endless chain**

2) Please always indicate the THIELE key design in case of order.
 Example (Pic. 2 from left): TK K1 2 / 13-8 M 1000 (without suffixes, because chain RAL 9006 (black coloured) and suspension link RAL 3000 (red)).



THIELE key design

					Trade Size		Reach	Component	Surface Finish		TWN
									Chain	Components	Plant Standard
TG	A	1		/	---	T	-----	TWN 0807	---	-----	449
TG	A	1		/	---	T	-----	TWN 0835/1	---	-----	0450/1
TG	A	1		/	---	T	-----	TWN 0854	---	-----	454
TG	A	1		/	---	T	-----	TWN 0856	---	-----	456
TG	A	1		/	---	T	-----	TWN 0870	---	-----	458
TG	A	1		/	---	T	-----	TWN 0871	---	-----	459
TG	A	1		/	---	T	-----	TWN 0859	---	-----	460
TG	A	1		/	---	T	-----	TWN 0861	---	-----	461
TG	A	1		/	---	T	-----	TWN 0862	---	-----	462
TG	A	1		/	---	T	-----	TWN 0858/1	---	-----	476/1
TG	A	2		/	---	T	-----	TWN 0808	---	-----	529
TG	A	2		/	---	T	-----	TWN 0835/1	---	-----	0530/1
TG	A	2		/	---	T	-----	TWN 0854	---	-----	534
TG	A	2		/	---	T	-----	TWN 0856	---	-----	536
TG	A	2		/	---	T	-----	TWN 0858/1	---	-----	566/1
TG	A	2		/	---	T	-----	TWN 0870	---	-----	538
TG	A	2		/	---	T	-----	TWN 0871	---	-----	539
TG	A	2		/	---	T	-----	TWN 0859	---	-----	540
TG	A	2		/	---	T	-----	TWN 0861	---	-----	541
TG	A	2		/	---	T	-----	TWN 0862	---	-----	542
TG	K	1	1	/	---	G	-----		---	-----	560
TG	A	2		/	---	T	-----	TWN 0829	---	-----	563
TG	A	4		/	---	T	-----	TWN 0809	---	-----	709
TG	A	4		/	---	T	-----	TWN 0835/1	---	-----	0710/1
TG	A	4		/	---	T	-----	TWN 0854	---	-----	714
TG	A	4		/	---	T	-----	TWN 0856	---	-----	716
TG	A	4		/	---	T	-----	TWN 0858/1	---	-----	735/1
TG	A	4		/	---	T	-----	TWN 0870	---	-----	718
TG	A	4		/	---	T	-----	TWN 0871	---	-----	7119
TG	A	4		/	---	T	-----	TWN 0859	---	-----	720
TG	A	4		/	---	T	-----	TWN 0861	---	-----	721
TG	A	4		/	---	T	-----	TWN 0862	---	-----	722
TG	K	2	3	/	---	M	-----		---	-----	731
TG	A	4		/	---	T	-----	TWN 829	---	-----	733



















Sling Chains Survey

1-Leg Sling Chains

TWN 0449	TWN 0450/1	TWN 0453/1	TWN 0454
TWN 0456	TWN 0458	TWN 0459	TWN 0460
TWN 0461	TWN 0462	TWN 0473	TWN 0475
TWN 0477/1			



2-Leg Sling Chains

<p>TWN 0529</p> 	<p>TWN 0530/1</p> 	<p>TWN 0533/1 0535/1</p> 	<p>TWN 0534</p> 
<p>TWN 0536</p> 	<p>TWN 0538</p> 	<p>TWN 0539</p> 	<p>TWN 0540</p> 
<p>TWN 0541</p> 	<p>TWN 0542</p> 	<p>TWN 0545</p> 	<p>TWN 0560</p> 
<p>TWN 0563</p> 	<p>TWN 0567/1</p> 		





4-Leg Sling Chains

TWN 0709	TWN 0710/1	TWN 0713/1 0715/1	TWN 0714
TWN 0716	TWN 0718	TWN 0719	TWN 0720
TWN 0721	TWN 0722	TWN 0730	TWN 0731
TWN 0733	TWN 0736/1		



Marine and Offshore



In the marine and Offshore industry Sling Chains are exposed rough environmental conditions under strong dynamic loads. For this special application THIELE, as authorized and certified manufacturer, supplies special calibrated welded Sling Chains as per D.N.V. 2.7-1.



Operating Manual

WARNING!

- Sling Chains and Components can only be used, if user instructions and operating instructions have been read carefully and are completely understood.
- The indicated values of loads on the I.D. tags must not be exceeded.
- Due to improper use, chains can fail.

IT'S A QUESTION OF YOUR SAFETY
Death or injury can occur from improper use or maintenance!

1. Transport and Storing

All products must be protected during transportation, use, and storage in severe weather conditions.

2. Before first use

Assembling, disassembling and using should only be accomplished by authorized persons as per BGR 500, Chapter 2.8 (in Germany) Check the following points before using the chain sling for the first time:

- all test certificates exist (declaration of conformity, inspection certificate 3.1.B etc.); the chain sling you are going to use is the same that you ordered
- Slinging Chains and Tensioning Chains are provided with the CE label
- identification and working load limit marked on the chain sling are identical to the corresponding information indicated on the test certificate; all details concerning the chain sling have been entered into the chain card file
- The mounting is prohibited until it has been found out, that the machine in which should be built in, corresponds with the EC Directive for machines and its amendments (European rules and regulations).
- In suitable intervals, check the chain sling for damages or wear (depending upon severity of conditions slings shall be inspected for damage as frequently as prior to each lift. All supplied user instructions must be maintained and available for reference until the product is removed from service.

3. Warning and use advice

- EC Directive for Machines and its amendments as per 2006/42/EG
- Operation and use instructions for sling chains as per DIN 685 - Part 5 -EN818 -6.
- Consult safety regulations for round steel chains used as slinging gear in hot dipped galvanizing plants (german rules and regulations) as per BGR 150
- Consult Safety Regulations for Cranes as per BGV D 6
- Consult load Suspension Devices for Lifting Operations (german rules and safety regulations) as per BGR 500, Chapter 2.8
- Consult Safety certificate for riggers as per BGI 556
- Consult components for sling chains as per EN 1677-2
- Consult principles for test of industrial safety of lifting products
- Consult slinging of rod iron using steel round steel chains when loading and unloading sea-going ships
- Consult German rules and regulations VDI

2700-2701-2702

Special Components, hooks and clutching devices should only be used in straight tensile direction

Especially forbidden is:

- the combination of different grades when assembling (except tongs)
- the using of chain slings which do not correspond to grade 100
- overloading
- To use a combination of products with different working load limits, unless the working load noted on the I.D. tag is based on the weakest component.
- the use of twisted or knotted chains
- to use bolts or wires to connect components
- to use deformed components, rigid or elongated chains
- to lift or pull loads with sharp edges without padding the edges
- to drive equipment over chain sling
- to multiple wrap a chain around a loadhook or tension point
- to modify products by welding, burning, bending or other mechanical modifications
- to make inadmissible modifications, e.g. the use of a 2-leg sling chain with shortening hooks as a 4-leg sling chain
- to tip load a hook into a chain link
- to apply the load on the tip, side or back of the hook
- to load connectors (XL-Lok s) at one side
- to adjust chain links or products
- to adapt inclination over 60°
- to turn swivels or swivel hooks under load
- to weld Lifting Point screw type lifting eyes
- to exceed the indicated grip on lifting tongs
- the use of open or riveted repair links

It must be taken into consideration:

In the event that THIELE Chain and Components are used in an automated process, all parts should be designed correspondingly larger and inspected at more frequent intervals!

- the load to be lifted
- the free mobility of the hook's safety latches
- the use under chemical influences for example acids and steam is restricted or prohibited
- the influence of temperature on alloy chain and components
- shock load impacts the chain or fitting while lifting or securing
- any type of surface treatment to chain or fittings especially of hot dipped galvanizing can only be carried out by the manufacturer
- when lifting keep hands and other parts of body far away from the components
- be careful when locking hooks under load
Danger of injury!
- when not in use sling chains must be hung on a rack
- ensure free mobility of chain slings or other devices in the crane hook
- when using hooks without latches pay special attention to the position of the hook placement
- to the installation position
- if necessary protect screw tensioners by locking elements to prevent automatic unlocking
- load claws with chains only on the bottom of

the pocket claws

- protect chain by padding or wrapping sharp edges
- Safety latches should not be obstructed when hooks are loaded
- in case of shortening hooks, load chains must be loaded in the bowl of the hook
- hook openings must point away from the load being lifted
- that the hook up point and lifting hooks are compatible
- also be sure that the lifting components are suitable for the application
- do not sit loads on the chain sling
- reduction of working load limits is necessary when making lifts at severe angles
- consult charts when using alloy chain at extreme temperatures
- working load limits must be reduced when using endless and basket slings
- extreme caution should be used when using hooks for lifting molten metal or chemicals
- chain slings shall be loaded properly to avoid damage to chain and load
- keep personnel away from loads being lifted

4. Maintenance and tests

- The chain sling must be visually inspected before use. If damage is found, you must consult a chain expert as per VG9a.
- The product must be removed from service if the following damage is found:
 - unreadable tags
 - breaks or deformation
 - cuts, notches, grooves or cracks
 - strong corrosion
 - heating over the admissible temperature allowed
 - elongation of chain must not exceed 5% of manufacturer's published size
 - elongation of the overall chain length shall not exceed 5 %
 - to determine wear rejection on the diameter of a link, you must measure the horizontal and the vertical and reject if reduction is more than 10%.
 - reject hooks if throat opening is opened greater than 10% of new hook or the safety latch does not seat properly
 - wear of hook eye or hook body exceed 5 %
 - missing or damaged safety latch of the hook or shortening component
 - incorrect screw replacement on lifting eyes
 - incorrect or damaged bolts or turn off locking

Don't repair chain slings yourself unless fully trained. Please contact the manufacturer or a repair expert. Use only original spare parts from THIELE.

5. Regular inspections

- Regular inspection shall include measurement and visual inspection and should be carried out once each year at minimum. Each third year inspection must include the crack detection (magna flux).
- On a new chain, you must set up chain card index that shall contain a description of the chain as well as the identity of the certificate. The inspection schedule must be fixed. The condition of sling chains or tensioning chains and their accessories must be noted at each inspection. If damage is repaired, all repairs and details must be noted on the chain card.

Download: www.thiele.de



THIELE



App



THIELE



Lifting Points



Product Overview Lifting Points

Page 116-120	TWN 0121/1 	TWN 0122 	TWN 0123 	TWN 0127 	TWN 1120 
	TWN 1830 	TWN 1890 			
Lifting Points, screwed type					

Page 124-128	TWN 0119 	TWN 0124 	TWN 0850/1 	TWN 1470 	TWN 1880 
	Lifting Points, weld-on type				

Page 131-132	TWN 0301 	TWN 0302 	TWN 0304 	TWN 0308 	TWN 0321 
	TWN 0323 				
Hitches					

Lifting Points

Select a suitable Lifting Point



1. Determine the **weight** of the load to be lifted.
2. Select the **type of application** according to the **number of legs** and position of the Lifting Points under load (see pictographs P. 112, 120).
3. Determine the area of **inclination angle**.



The chart displays various lifting point configurations categorized by application type (e.g., 1-leg, 2-leg, 3-leg, 4-leg) and includes columns for weight capacity, thread diameter, and other technical specifications. It is a detailed technical reference tool for selecting the appropriate lifting point based on specific requirements.

4. Consider the **temperature** influence:

Application between -40° up to $+200^{\circ}\text{C}$ (Screwed type up to -20°C):

Full weight under point **1** can be considered.

Application between $+200^{\circ}$ up to $+300^{\circ}\text{C}$:

Divide the weight under point **1** by reduction factor 0,90

Application between $+300^{\circ}$ up to $+380^{\circ}\text{C}$:

Divide the weight under point **1** by reduction factor 0,60

5. Obtain the working load limit, thread diameter and marking by selecting the appropriate application, inclination angle, number of legs and the type of Lifting Point.



Working Load Limit Table for Lifting Points, screwed type



			TWN 0121/1 Lifting Point swivel type				TWN 0122 Lifting Point (2 Screws)								TWN 0123 Lifting Point			TWN 0127 Lifting Point MDB	
Use Case	Inclination Angle β	No. of Legs	GK8																
			   																
Working Load Limits in [t]																			
Marking			1,12	2	3,15	5,3	3,15	5,3	8	15	21,2	25	31,5	36	1,12	2	3,15	3,15	5,3
Screw Size			M16	M20	M24	M30	M16	M20	M30	M36	M42	M45	M56	M56	M16	M20	M24	M20	M24
	0°	1	1,12	2	3,15	5,3	3,15	5,3	8	15	21,2	25	31,5	36	1,12	2	3,15	3,15	5,3
	0°	2	2,24	4	6,3	10,6	6,3	10,6	16	30	42,4	50	63	72	2,24	4	6,3	6,3	10,6
	90°	1	1,12	2	3,15	5,3	3,15	5,3	8	15	21,2	25	31,5	36	1,12	2	3,15	3,15	5,3
	90°	2	2,24	4	6,3	10,6	6,3	10,6	16	30	42,4	50	63	72	2,24	4	6,3	6,3	10,6
	0-45°	2	1,6	2,8	4,25	7,5	4,25	7,5	11,2	21,2	30	33,5	45	50	1,6	2,8	4,25	4,25	7,5
	45-60°	2	1,12	2	3,15	5,3	3,15	5,3	8	15	21,2	25	31,5	36	1,12	2	3,15	3,15	5,3
	unbalanced	2	1,12	2	3,15	5,3	3,15	5,3	8	15	21,2	25	31,5	36	1,12	2	3,15	3,15	5,3
	0-45°	3+4	2,36	4,25	6,7	11,2	6,7	11,2	17	31,5	45	50	67	75	2,36	4,25	6,7	6,7	11,2
	45-60°	3+4	1,7	3	4,75	8	4,75	8	11,8	22,4	31,5	37,5	47,5	53	1,7	3	4,75	4,75	8
	unbalanced	3+4	1,12	2	3,15	5,3	3,15	5,3	8	15	21,5	25	31,5	36	1,12	2	3,15	3,15	5,3



New

New



Working Load Limits in [t]

0,3	0,45	0,6	1,4	2,5	3,5	6,7	8	0,45	0,6	1,4	2,5	3,5	5,3	8	10	12,5	12,5	17	0,5	0,8	1,5	2,5	4	5	6	8	10	12
M8	M10	M12	M16	M20	M24	M30	M36	M10	M12	M16	M20	M24	M30	M36	M42	M45	M48	M56	M10*	M12*	M16	M20	M24	M27*	M30*	M36*	M42*	M48*
0,3	0,45	0,6	2,1	3	6	7,1	12,5	0,9	1,2	2,8	5,3	7	10	15	18	20	20	28			1,7	2,5	4,0					
0,6	0,9	1,2	4,2	6	12	14,2	25	1,8	2,4	5,6	10,6	14	20	32	36	40	40	56			3,4	5,0	8,0					
0,3	0,45	0,6	1,4	2,5	3,5	6,7	8	0,45	0,6	1,4	2,5	3,5	5,3	8	10	12,5	12,5	17			1,7	2,5	4,0					
0,6	0,9	1,2	2,8	5	7	13,4	16	0,9	1,2	2,8	5	7	10,6	16	20	25	25	34			3,4	5	8,0					
0,42	0,63	0,85	2	3,55	5	9	11,2	0,63	0,85	2	3,55	5	7,5	11,2	14	17,5	17,5	23,6			2,4	3,5	5,7					
0,3	0,45	0,6	1,4	2,5	3,55	6,7	8	0,45	0,6	1,4	2,5	3,55	5,3	8	10	12,5	12,5	17			1,7	2,5	4,0					
0,3	0,45	0,6	1,4	2,5	3,55	6,7	8	0,45	0,6	1,4	2,5	3,55	5,3	8	10	12,5	12,5	17			1,7	2,5	4,0					
0,63	0,95	1,25	3	5,3	7,1	14	17	0,95	1,25	3	5,3	7,1	11,2	17	21,2	26,5	26,5	35,5			3,6	5,3	8,5					
0,45	0,67	0,9	2,1	3,8	5,3	10	11,8	0,67	0,9	2,1	3,8	5,3	8	11,8	15	18,8	18,8	25			2,6	3,8	6,0					
0,3	0,45	0,6	1,4	2,5	3,55	6,7	8	0,45	0,6	1,4	2,5	3,55	5,3	8	10	12,5	12,5	17			1,7	2,5	5,0					

Please also see W.L.L. in hinged load direction page 119

* in development



Lifting Points, screwed type



Lifting Point **GK8** TWN 0121/1

a true Athlete – powerful and strong even under extreme loads.

The two forged parts make this lifting point particularly sturdy for lifting, moving and securing loads. Our TWN 0121/1 lifting point features full load working load limit in all tension directions, and can be rotated 360° and swivelled 180°. The THI-LOK half features electrolytic treatment and is more corrosion-resistant in the area of the greatest wear, all of which gives this lifting point an especially long serviceable life.

This BG-approved safety component that moves expensive machinery or steel elements has undergone 100% electromagnetic crack-testing and is delivered including operating instructions.

Finish: RAL 3003, electro galvanized and yellow chromated



Screw Size	Article-No.	Working Load Limit [t max]	Marking DSK-N G	Dimensions [mm]							Weight app. [kgs]		
				E	F	A	C	H	B	D		NG	
M16	F35000	1,12	1	65	30	61	65	38	22	12	12	6-8	0,70
M20	F35010	2,00	2	85	40	79	82	49	28	15	15	8-8	1,50
M24	F35020	3,15	3	98	45	92	101	59	33	19	19	10-8	2,60
M30	F35030	5,30	5	120	53	113	125	72	45	25	25	13-8	4,60

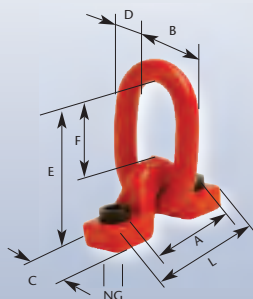

Lifting Point **GK8** TWN 0122

Notably high Quality for notably high demands.

Our design engineers have developed a lifting/lashing point for mechanical engineering and plant construction that is distinctive in its compact construction. The extra wide intermediate link simplifies hooking-in in the broadest variety of hook types. This makes fast, smooth transport easy. The full working load limit in every direction of tension enables unlimited functionality, even with extremely heavy loads. Delivery includes the 100% crack-tested, high strength special screws along with operating instructions.

Finish: RAL 3003



Screw Size	Article-No.	Working Load Limit [t max]	Marking DSK-N G	Dimensions [mm]							Weight app. [kgs]	
				E	F	A	C	L	D	B		NG
M16	F35070	3,15	3	112	57	90	38	130	18	40	10-8	1,54
M20	F35075	5,30	5	149	79	115	48	165	22	50	13-8	2,83
M30	F35080	8,00	8	183	93	150	62	212	26	65	16-8	5,87
M36	F35095	15,00	15	226	114	175	72	255	36	75	22-8	11,20
M42	F35098	21,20	20	272	142	200	90	295	45	95	26-8	19,30
M45	F35101	25,00	25	272	142	200	90	295	45	95	28-8	20,20
M56	F35102	31,50	32	336	193	230	100	330	48	110	32-8	31,70
M56	F35285	36,00	36	336	193	230	100	330	48	110	34-8	31,70



Lifting Points, screwed type

Lifting Point **GK8** TWN 0123

Simple and economic.

Our TWN 0123 threaded lifting point is easy to mount very quickly. All you need is a threaded bore hole. This captive unit features compact construction and only requires minimum assembly space. The attachment link is optionally available as a master link or intermediate link, making it adaptable to the specific job at hand. This means we have the right solution for your requirements, even at low mounting heights. The lifting point is constructed of high-strength tempered and powder-coated steel. Delivery includes operating instructions.

Finish: RAL 3003

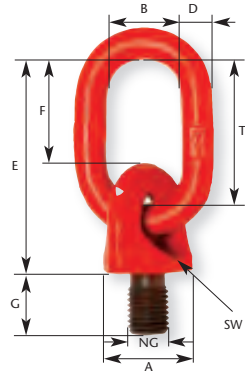

Screw Size	Article-No.	Working Load Limit [t max]	Thread Length [mm] G	Dimensions [mm]								Weight app. [kgs]
				E	F	D	T	B	B	SW	A	
M16	F34110	1,12	30	113	52	16	70	34	46	60	6-8	0,73
M16	F34115	1,12	30	153	92	16	110	60	46	60	6-8	1,00
M20	F34120	2,00	38	113	52	16	70	34	46	60	8-8	0,95
M20	F34121	2,00	38	153	92	16	110	60	46	60	8-8	1,12
M24	F34130	3,15	35	128	67	18	85	40	46	60	10-8	1,04
M24	F34131	3,15	35	153	92	18	110	60	46	60	10-8	1,39

Lifting Point **GK8** MDB TWN 0127

Reliable – Trustworthy – dependable.

Delivery of our precision-tooled threaded TWN 0127 lifting point includes the necessary screws. It can be mounted and removed very quickly using common tools. Our engineers have constructed a component with the largest possible contact surface, subsequently ensuring highly effective attachment thanks to the flat contact surface of the bolt-on bracket and a mirrored screw head surface.

Finish: RAL 3003

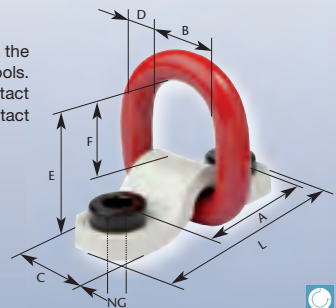

Screw Size	Article-No.	Working Load Limit [t max]	Dimensions [mm]								Weight app. [kgs]
			E	F	A	C	L	D	B	NG	
M20	F35157	3,15	68	48	90	44	130	18	48	10-8	1,10
M24	F35158	5,80	113	69	110	60	160	24	66	13-8	2,70



Lifting Points, screwed type

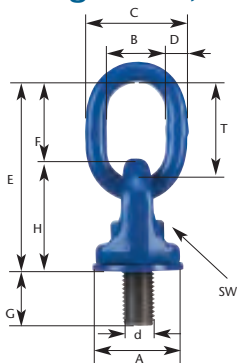

The **TITAN Lifting Point XL TWN 1120** is capable to lift with the nominal working load limit in all directions. The coupling link is unlimited in all directions free movable. It rotates easily due to the special bush and glide plate, made from stainless steel. Built as a compact one piece unit, it requires less space for the assembly.

The TITAN Lifting Point allows a fast and easy assembling with common tools and can be supplied with other screw lengths upon request. A plastic net cover protects the screw during shipment and storage.

100% Magnetic crack tested. BG - approved.

Warning: Does not swivel under load!

Finish: RAL 5002



Screw Size [d]	Article-No.	Working Load Limit [t max]	Thread Length [mm] G	Dimensions [mm]								Weight app. [kg]	
				E	F	D	T	B	A	C	H		SW
M8	F34405	0,30	19	95	40	10	50	28	43	50	55	13	0,40
M10	F34390	0,45	19	95	40	10	50	28	43	50	55	16	0,41
M12	F34395	0,60	24	95	40	10	50	28	43	50	55	18	0,43
M16	F34400	1,40	29	95	40	10	50	28	43	50	55	24	0,47
M20	F34410	2,50	33	115	49	12	60	34	54	60	66	30	0,79
M24	F34420	3,50	40	135	55	16	70	40	65	74	80	36	1,50
M30	F34430	6,70	52	167	66	18	85	50	85	93	101	46	3,00
M36	F34440	8,00	66	212	92	22	115	50	96	107	120	55	4,80

The right turn!



Lifting Points, screwed type

The X-TREME Lifting Point **XL TWN 1830**

is equipped with a ball bearing system. It has a special wide coupling link which enables an easy slinging of bigger hooks. It is particularly well suited for loads that have to be turned or flipped. The octagonal shap of the subpart enables an easy assembling with a common hand tool. 100% Magnetic crack tested. According to the principles of the BG GS-0A-15-04

Like the TITAN Lifting Point the X-TREME Lifting Point is capable to lift with the nominal working load limit in all directions. The X-TREME Lifting Point is not suitable for permanent rotations under load.

Finish: RAL 5002, electro galvanized and yellow chromated

New

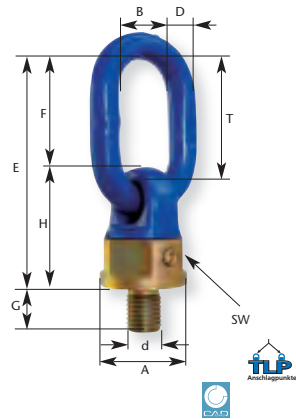

Description	Working Load (WLL)			Screw Size	Article-No.	Dimensions								Weight
	Vertical Y [t]	Extreme Z [t]	Hinged X [t]			[d x G]	E	F	D	T	B	A	SW	
X-TRE 0,45	0,9	0,45	0,6	M10 x 15	F34306	101	46,5	13	55	33	39	36	54,5	0,50
X-TRE 0,60	1,2	0,60	0,7	M12 x 18	F34307	101	46,5	13	55	33	39	36	54,5	0,50
X-TRE 1,40	2,8	1,4	1,7	M16 x 20	F34300	101	46,5	13	55	33	39	36	54,5	0,50
X-TRE 2,50	5,3	2,5	2,8	M20 x 25	F34310	121	58,5	16	70	34	50	46	62,5	0,90
	5,3	2,5	2,8	M20 x 50	F34312	121	58,5	16	70	34	50	46	62,5	1,00
X-TRE 3,50	7	3,5	4	M24 x 30	F34320	148	72	18	85	40	57	50	76	1,50
	7	3,5	4	M24 x 90	F34321	148	72	18	85	40	57	50	76	1,70
X-TRE 5,30	10	5,3	6,3	M30 x 40	F34330	170,5	83	22	100	50	73	65	87,5	2,70
X-TRE 8,00	15	8	9,5	M36 x 50	F34340	179	81	22	100	50	83	70	98	3,60
	15	8	9,5	M36 x 63	F34341	179	81	22	100	50	83	70	98	3,80
	15	8	9,5	M36 x 70	F34343	179	81	22	100	50	83	70	98	3,90
X-TRE 10,00	18	10	12,5	M42 x 60	F34350	244	116	32	140	70	106	95	128	8,30
X-TRE 12,50	18	12,5	15	M45 x 65	F34353	244	116	32	140	70	106	95	128	8,40
	20	12,5	16	M48 x 68	F34355	244	116	32	140	70	106	95	128	8,60
X-TRE 17,00	28	17	22	M56 x 78	F34360	251	116	32	140	70	116	95	135	10,00

Variable screw lengths up to 3 x d available at thread diameter M20, M24, M30, M36.

*Load Direction hinged

Load Direction

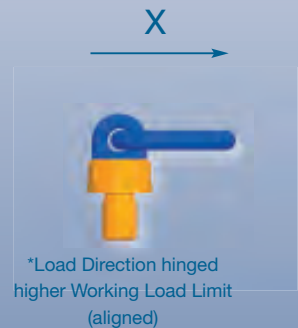
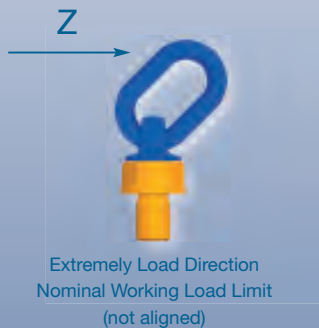



Lifting Points, screwed type

New

XS-Lifting Point **XL** TWN 1890

A piece of individualism combined with technology for more safety.

Our new XS-Lifting Point TWN 1890 has a 100% nominal working load limit in all tensile directions and it can also be rotated by 360° and swivelled by 180°. Our engineers designed a Lifting Point which guarantees a fast and uncomplicated mounting and removal using a standard open-end spanner. The extrawide bow enables load hooks of a large nominal size to be used for slinging without any difficulty.

The XS-Lifting Point is especially designed for the exchange of the screws and therefore screw lengths.

Finish: RAL 5002, electro galvanized and yellow chromated

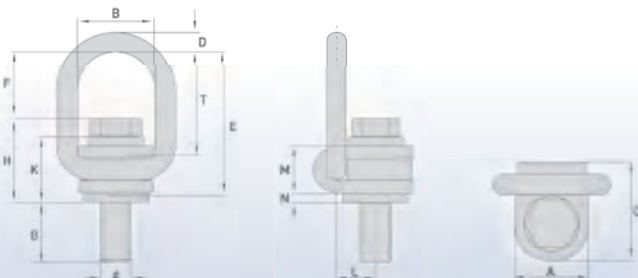

Screw Size [d]	Article-No.	Working Load Limit [t max]	Thread Length [mm] G	Dimensions [mm]											
				E	F	D	T	B	A	C	H	K	L	M	N
M10*	F35243	0,50	17	96	51,5	13	70	50	48	64	44,5	38,0	25,0	30,0	5
M12*	F35244	0,80	22	96	50,5	13	70	50	48	64	45,5	38,0	25,0	30,0	5
M16	F35245	1,70	30	97	46,5	13	70	50	48	64	50,0	40,0	25,0	30,0	5
M20	F35246	2,50	38	98	43,0	13	70	50	48	64	54,5	42,0	25,0	30,0	6
M24	F35247	4,00	41	134	70,0	16	102	58	50	71	64,0	50,0	28,0	38,5	6
M27*	F35248	5,00	50	145	67,5	18	105	75	72	92	77,5	60,5	35,0	44,5	12
M30*	F35249	6,00	58	146	64,5	18	105	75	72	92	81,5	62,5	35,0	44,5	12
M36*	F35250	8,00	70	199	96,0	32	140	100	95	148	103,0	80,5	50,0	60,5	15
M42*	F35251	10,00	78	200	91,5	32	140	100	95	148	108,5	82,5	50,0	60,5	15
M48*	F35252	12,00	76	201	86,5	32	140	100	95	148	114,5	84,5	50,0	60,5	15

* in development









Lifting Points, screwed type

XS-Lifting Point **XL** TWN 1890



Working Load Limit Table for Lifting Points, weld-on type



			TWN 0119 Lifting Point								TWN 0124 Lifting Point with fixing spring				
Use Case	Inclination Angle β	No. of Legs	 												
			Working Load Limits in [t]												
Marking			1,12	2	3,15	5,3	8	15	31,5	50	1,12	2	3,15	5,3	8
	0°	1	1,12	2	3,15	5,3	8	15	31,5	50	1,12	2	3,15	5,3	8
	0°	2	2,24	4	6,3	10,6	16	30	63	100	2,24	4	6,3	10,6	16
	90°	1	1,12	2	3,15	5,3	8	15	31,5	50	1,12	2	3,15	5,3	8
	90°	2	2,24	4	6,3	10,6	16	30	63	100	2,24	4	6,3	10,6	16
	0-45°	2	1,6	2,8	4,25	7,5	11,2	21,2	45	71	1,6	2,8	4,25	7,5	11,2
	45-60°	2	1,12	2	3,15	5,3	8	15	31,5	50	1,12	2	3,15	5,3	8
	unbalanced	2	1,12	2	3,15	5,3	8	15	31,5	50	1,12	2	3,15	5,3	8
	0-45°	3+4	2,36	4,25	6,7	11,2	17	31,5	67	106	2,36	4,25	6,7	11,2	17
	45-60°	3+4	1,7	3	4,75	8	11,8	22,4	47,5	75	1,7	3	4,75	8	11,8
	unbalanced	3+4	1,12	2	3,15	5,3	8	15	31,5	50	1,12	2	3,15	5,3	8



New

New

TWN 0850/1 Excavator Hook	TWN 1470 ZK Module	TWN 1880 Lifting Point
------------------------------	-----------------------	---------------------------

 <p>GK8</p>	 <p>GK8</p>	 <p>XL</p>
---	---	--



Working Load Limits in [t]						Lashing Capacity (LC) [daN]					
1,12	2	3	5	8	10	5.000	10.000	3.000	5.000	8.000	13.500
						5.000	10.000	3.000	5.000	8.000	13.500
						5.000	10.000	3.000	5.000	8.000	13.500
						5.000	10.000	3.000	5.000	8.000	13.500



Lifting Points, weld-on type

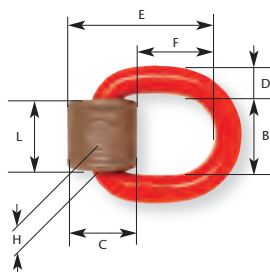

Welded Lifting Point **GK8** TWN 0119

A safety & security milestone thanks to the utilisation of high-strength steel. Our BG approved TWN 0119 attachment point is manufactured from high-strength, specially tempered steel. It features 4-times security safeguarding against breakage in all tension directions and is available with a working load limit of up to 50 tonnes. Its universal application for lifting and lashing make this component a true all-rounder. It can be welded easily and quickly to any steel construction thanks to its pre-aligned weld joint on the weld-on bracket and the accompanying welding instructions. Operating instructions are included in delivery.

Finish: RAL 3003



Trade Size	Article-No.	Working Load Limit [t max]	Lashing Capacity [daN]	Marking DSK-N	Dimensions [mm]								Weight app. [kgs]
					E*	F*	C	L	H	D	B		
6-8	F35103	1,12	2200	1	59	31	32	32	28	12	36	0,24	
8-8	F35113	2,00	4000	2	69	37	38	38	33	14	42	0,46	
10-8	F35123	3,15	6300	3	84	46	45	44	38	18	48	0,63	
13-8	F35133	5,30	10000	5	120	69	60	60	51	24	66	1,90	
16-8	F35143	8,00	16000	8	127	66	68	65	61	28	72	2,67	
22-8	F35163	15,00		15	178	98	96	109	80	39	120	8,09	
32-8	F35183	31,50		32	292	174	145	165	118	56	180	27,30	
40-8	F35193	50,00		50	371	228	186	210	145	72	230	60,00	

* E- and F-Dimension vertical to the welding level

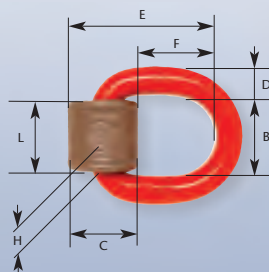

Welded Lifting Point **GK8** with Spring TWN 0124

Guaranteed fast, easy handling
This lifting point is easily and quickly welded to any steel construction. The weld-on bracket is already prepared at delivery to accommodate the required weld joint. An inserted spring additionally holds the D-bracket in the desired position. The resulting noise reduction makes this lifting point particularly suited for utilisation as a load securing lashing point. This also simplifies attachment to the pre-aligned lifting point. Like all of our lifting points, this one is equally approved by BG and is delivered with operating instructions.

Finish: RAL 3003



Trade Size	Article-No.	Working Load Limit [t max]	Lashing Capacity [daN]	Marking DSK-N	Dimensions [mm]								Weight app. [kgs]
					E*	F*	C	L	H	D	B		
6-8	F35107	1,12	2200	1	56	30	32	32	28	12	36	0,25	
8-8	F35110	2,00	4000	2	67	37	38	38	33	14	42	0,43	
10-8	F35124	3,15	6300	3	81	45	45	44	38	18	48	0,72	
13-8	F35139	5,30	10000	5	117	69	60	60	51	24	66	1,90	
16-8	F35144	8,00	16000	8	122	67	68	65	61	28	72	2,80	

* E- and F-Dimension vertical to the welding level

Lifting Points, weld-on type

Weld-On Hook **GK8** TWN 0850/1

Uniting Stability, Functionality and Safety.

The TWN 0850/1 weld-on hook is a component that is relevant for safety and is primarily welded onto earth-moving machinery extension arms, trusses or excavation buckets in applications involving the lifting and moving of loads. The hook and the safety latch both feature forged construction, ensuring robust, reliable, risk-free handling. Our TWN 0850/1 weld-on hook can bear loads of up to 10 tonnes and is delivered with all the necessary documentation.

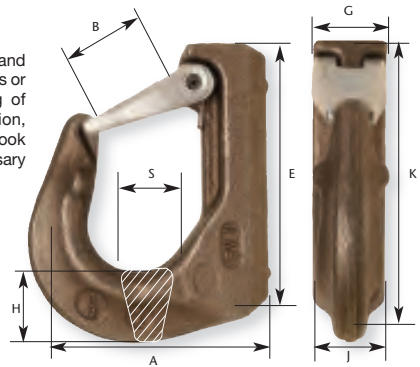

Finish: self colored
Pic.: Type GH2

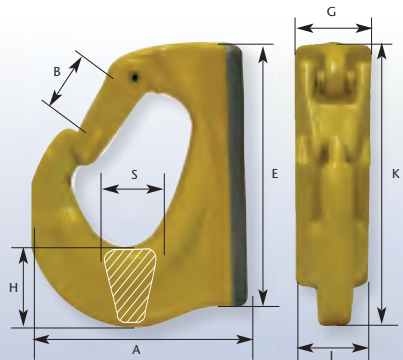

Finish: yellow
Pic.: Type for Trade Size from GH3

Trade Size	Article-No. yellow	Article-No. red	Article-No. self colored	Working Load Limit [t max]	Dimensions [mm]								Weight app. [kgs]
					B	E	F	G	H	J	K	S	
GH1	Z04499	–	F32751	1,12	26	85	77	24	24	24	94	20	0,52
GH2	–	–	F32752 ¹⁾	2,00	33	107	97	30	28	30	120	26	0,84
GH3	Z05449	Z06068	–	3,00	29	117	105	36	31	36	131	24	1,18
GH5	Z05836	Z05629	–	5,00	34	161	133	47	45	44	173	29	2,55
GH8	Z05630	Z06070	–	8,00	35	166	135	47	52	52	178	39	3,30
GH10	Z05837	–	–	10,00	49	205	168	47	57	54	202	39	4,20

1) W.L.L. values as per standard EN 1677-1. Test requirements according to test principle of Excavator Hooks for earthmoving equipments at lifting application (GS-MO 15-03) of the safety association.

NOTE: The component must approve a strength introduction at the chosen place! Welding works are to be carried out in accordance with the delivered welding instructions! Further operating instruction and the standard DIN 15429 is to be considered!



Lifting Points, weld-on type



Lashing Point ZK Module **GK8** TWN 1470

The newly developed ZK module from THIELE is a lashing ring with a cassette that can easily be adapted and attached to the side frames of trailers. These lashing rings are made of the same steel used in the manufacture of lashing chains. The THIELE ZK module is additionally approved by the German TÜV inspection board and complies with the European standard DIN EN 12640.

It also offers 100% lashing capacity and is capable of withstanding strain in all directions of strain. The lashing point has a swivel range of 150°, enabling the secure strapping of low-load goods as well as goods that project beyond the load platform. Besides this, the lashing ring is retractable, consequently preventing accidents from happening when walking on the cargo area.

Finish: RAL 3003

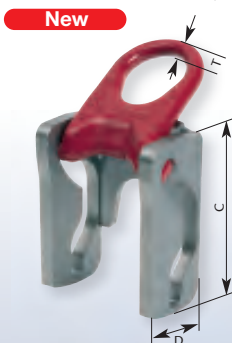

Trade Size	Article-No.	Lashing Capacity (LC) [daN]	Dimensions [mm]						Weight app. [kgs]
			A	B	C	D	E	T*	
5	F35236	5.000	107	12	144	72	50	14	2,60
10	F35237	10.000	137	15	144	72	60	18	3,60



Lashing Point ZK Module **GK8** TWN 1470

Lashing points and elements must meet the requirements specified in DIN EN 12640. This standard spells out the minimum needs and test requirements for lashing points on road trucks and trailers with flatbed bodies and a permissible GVW of more than 3.5 t which are meant for mixed cargo transportation.

Lashing points in this context are attachment devices/arrangements on a vehicle to which a load securing device can be directly fastened. A lashing point may, for example, be designed as an oval link, hook, and eyelet or lashing rail. It is in this technical context that problems are most frequently noticed in practice. An inexperienced sizing and use of unsuitable lashing points may not only cause damage to the lashing point itself and the vehicle frame, but also create very serious hazards to road traffic and safety.

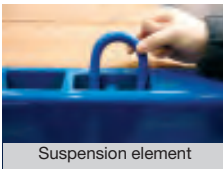

If a lashing design includes a suspension link, unforeseeable bending moments are often encountered which may result in damage to the lashing point and car body. More often than not, the arising angles are left out of consideration. Moreover, if not in use the suspension links lead to unnecessary noise pollution when the vehicle is on the road.

The ZK module (lashing ring with cassette) newly developed by THIELE can be attached most easily and safely to the lateral frame of trailers. The lashing rings are made of the same steel material as are used for the manufacture of the lashing chains. THIELE's ZK module has also been approved by the TÜV inspections agency and corresponds to European standard

DIN EN 12640; it has 100 % lashing capacity in all pulling directions. The lashing ring offers a 150° swivel range and enables cargo of low height as well as load items projecting over the load area to be safely secured. Furthermore, the lashing ring can be folded away thus preventing accidents when people move on the cargo platform.

GVW = Gross Vehicle Weight

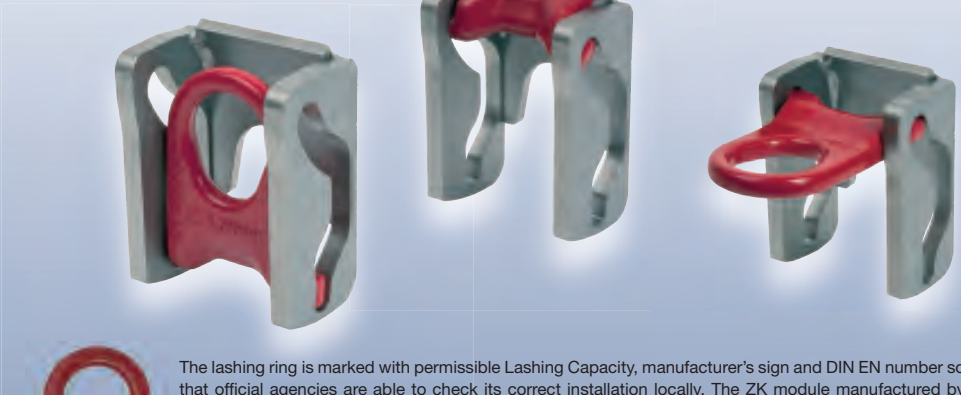

Lashing Ring

The lashing ring is marked with permissible Lashing Capacity, manufacturer's sign and DIN EN number so that official agencies are able to check its correct installation locally. The ZK module manufactured by THIELE provides maximum safety for cargo securing and is thus highly instrumental in road traffic safety.



New

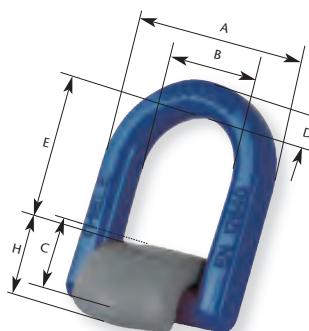

Welded Lashing Point **XL** with spring TWN 1880

A perfect interaction between compactness and easier handling.
The small size of the TWN 1880 lashing point was at the focus during the development of this weld-on lashing point. The high working load limit/lashing capacity when compared with its compact design is what makes the lashing point something special. It can be swivelled by 180°.

100% Magnetic crack tested.

Finish: RAL 5002



Trade Size	Article-No.	Nominal Size [mm]	Lashing Capacity (LC)* [daN]	Dimensions [mm]						Weight app. [kgs]
				D	B	A	E*	H	C	
6-XL	F35204	6	3.000	14	38	65	42	25	49	0,42
8-XL	F35205	8	5.000	15	45	76	45	27	50	0,57
10-XL	F35206	10	8.000	17	50	85	57	31	55	0,85
13-XL	F35207	13	13.500	23	68	116	79	44	77	2,20
16-XL	F35208	16	20.000	27	69	130	72	54	92	3,35

* upright standing ring

Operating Manual Lifting Points, screwed type TWN 0121, TWN 0122, TWN 0123, TWN 0127, TWN 1120, TWN 1830, TWN 1890

1 Introduction

THIELE screw-type lifting rings serve to secure components/loads by means of hoisting means, for instance chain suspensions, to enable handling activities to be performed safely.

The present operating manual includes information on how lifting rings of the following types are safely used:

- TWN 0121/1 Lifting ring, rotatable, with slide bearing
- TWN 0122 Lifting ring
- TWN 0123 Lifting ring
- TWN 0127 Lifting ring MDB
- TWN 1120 TITAN Lifting ring, rotatable, with slide bearing
- TWN 1830 X-TREME Lifting ring, rotatable, with ball bearing

TWN = THIELE-company standard

2 Intended Use

The lifting rings are intended for attachment to steel, aluminum or non-ferrous metal structures and components.

They serve to connect the structures and components to hoisting means used for handling.

The lifting rings must exclusively be used

- as prescribed by their permissible load carrying capacity,
- within the temperature limits prescribed,
- with appropriate screws/bolts (refer to Chapter 5) firmly attached to the components to be lifted.

3 Safety Notes

3.1 Personnel

Operators must familiarize themselves with this operating manual as well as regulation BGR 500, Chapter 2.8 „Betreiben von Lastaufnahmeeinrichtungen im Hebezeugbetrieb“ (Use of load suspension devices for hoisting purposes) as issued by German Accident Prevention & Insurance Association).

Mounting and removal must exclusively be carried out by authorized persons.

Outside the Federal Republic of Germany the specific provisions issued locally in the country where the items are used must also be observed.

3.2 Product Safety

Risk of Injury

Make sure to use lifting rings free from defects.

- Never use worn-out, bent or damaged lifting rings.
- Never make structural changes to lifting rings (e.g. by welding, bending).

3.3 Use

Risk of Injury

Never stay under lifted loads.

- Only lift loads the weight of which is less than or equal to the carrying capacity of the suspension gear.
- Never subject lifting rings to loads higher than their specified carrying capacity.
- Do not use force when mounting/positioning the lifting rings.
- Do not start lifting before you have made sure that the load has been correctly attached.
- Make sure nobody stands or walks under or near suspended loads.

- Never move a suspended load over persons.

When lifting loads make sure your hands or other body parts do not come into contact with the suspension gear.

- Never cause a suspended load to swing.
- Make sure lifting rings are mounted above the load's center of gravity.
- The mounting location of the rings on the component must be suited for the forces admitted via the lifting ring to be safely absorbed without the component suffering deformation.

4 Product Description

THIELE lifting rings are marked with nominal carrying capacity (WLL) in tons or nominal size of the chain. This indication only applies to the lifting ring itself and

not to the overall load or suspension gear used.

The lifting rings are in conformity with Machinery Directive 2006/42/EG and marked with the CE symbol. The rings have been type tested by "Metallberufsgenossenschaft Nord Süd" and marked with the H-stamp.

6 Mounting

6.1 Preparations

Make sure the attachment faces are flat and dry and the tapped hole is made perpendicular to the attachment face.

6.2 Mounting the Lifting Ring

Mount the lifting ring so that

- no areas of danger are created,
- structural parts cannot cause the suspension gear to be deflected when the load is lifted,
- the suspension gear cannot be damaged, e.g. by sharp edges.



The useful depth of the thread must enable the lifting rings to be safely screwed in.

Make sure the tapped hole is arranged at right angle to the attachment face on the component. The depth of thread „L“ in the component must at least be as follows:

L = 1	x d	in steel
L = 1.25	x d	in castings
L = 2	x d	in aluminum
L = 2.5	x d	in aluminum-magnesium alloys (where L = depth of thread; d = thread diameter)

- Make sure the threads of the lifting ring and in the component are clean and dry.
- TWN 0123, TWN 1120 and TWN 1830: Use a suitable open-ended spanner to fix the lifting rings so as to be finger-tight.
- TWN 0121/1, TWN 0122 and TWN 0127: Tighten the screws at the tightening torques specified in Chapter 5.

- If the lifting rings are to remain on the component make sure to use liquid agents to secure and safeguard the screws.
- In case of through-boltings secure the nuts by suitable locking means.

7 Application

7.1 Use under Normal Conditions

The top part of the lifting ring including attachment link must always be freely movable. It must not rest on or be supported by other structural parts. When attaching the components make sure the position of the lifting ring always enables forces to be exerted in longitudinal direction.

Make sure only the top part of the lifting rings turns into loading direction and not the firmly secured stationary portion.

TWN 1830:

The lifting ring must not be used for a permanent or prolonged turning of the load.

7.2 Influence of Temperature

The permissible carrying capacity of the lifting rings reduces at elevated temperatures.

The reduced carrying capacity figures shown in the following table shall only apply for short-term use at the temperatures indicated.

TWN 0121/1, TWN 0122, TWN 0127, TWN 1120:

Temperature range	Remaining carrying capacity
from -30 °C to 100 °C =>	100 %
from 100 °C to 200 °C =>	85 %
from 200 °C to 250 °C =>	80 %
from 250 °C to 300 °C =>	75 %

TWN 0123, TWN 1830:

Temperature range	Remaining carrying capacity
from -30 °C to 200 °C =>	100 %
from 200 °C to 300 °C =>	90 %
from 300 °C to 400 °C =>	75 %

When the rings are to be used within other temperature ranges please get in touch with the manufacturer.

7.3 Environmental Influence

In case the rings shall be used under the influence of chemicals please consult with the manufacturer.

8 Maintenance

8.1 Inspections

Check the lifting rings visually at regular intervals. The results of the inspection shall be entered into a register to be prepared when the lifting ring is first used.

This register includes characteristics of the ring as well as identification particulars (Statement of compliance/inspection certificate).

An inspection must be carried out at least once a year or more frequent if the rings are in heavy-duty service. After three years at the latest the rings shall be examined for cracks.

The condition of lifting ring and its components must be documented during these inspections.

When making repairs to lifting rings note down the cause of the defect and the remedial action that has been taken.

Immediately stop using lifting rings that show the following defects:

- Deformation,
- Cuts, notches, cracks, incipient cracks,
- Rings cannot freely rotate or turn,
- Rings have been heated beyond permissible limits,
- Severe corrosion,
- Wear exceeding 10%, e.g. in the suspension link diameter area,
- Identification marks are unreadable,
- Defect screws/bolts,
- TWN 1830: Size of gap s exceeds figures in table below.

Max. gap size „s“ for TWN 1830:

Nominal size	s [mm]
NG 6	1.5
NG 8	1.5
NG 10	2.0
NG 13	2.5
NG 16	3.0

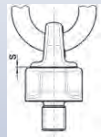

8.2 Repairs

Only use THIELE spare parts. Exclusively use original THIELE screws and bolts because these are made to meet special requirements. If defects are detected make sure to repair the lifting ring before it is used again.

9 Storage

Store the lifting rings in dry space at temperatures

between 0 °C and +40 °C.

Secure lifting rings by applying suitable screw locking means to prevent screws from working loose.

All informations of this documentation were checked and verified carefully.

The THIELE GmbH & Co. KG assumes no liability for failures or damage caused by the usage of this informations. Subject to modifications.

THIELE reserves the right to modify products without any announcing.

The intellectual property rights of this documentation remain at THIELE GmbH & Co. KG.

Every usage (i.e. duplicating) of this documentation without agreement of THIELE is not allowed and makes liable to pay damages.

Download: www.thiele.de

Operating Manual Lifting Points, weld-type TWN 0119, TWN 0124 with spring, TWN 1880

1 Introduction

THIELE weld-type lifting rings serve to secure components/loads by means of hoisting means, for instance chain suspensions, to enable handling activities to be performed safely. They can also be used for lashing purposes.

The present operating manual includes information on how lifting rings of the following types are safely used:

- TWN 0119 Lifting ring, weld-type
- TWN 0124 Lifting ring, weld-type, with spring

TWN = THIELE-company standard

2 Intended Use

The lifting rings are intended for attachment to steel, aluminum or non-ferrous metal structures and components.

They serve to connect the structures and components to hoisting means used for handling or secure loads. The lifting rings must exclusively be used

- as prescribed by their permissible load carrying capacity or lash-ing force,
- within the temperature limits prescribed,
- with properly laid weldings seams.

3 Safety Notes

3.1 Personnel

- Operators must familiarize themselves with this operating manual as well as regulation BGR 500, Chapter 2.8 „Betreiben von Lastaufnahmeeinrichtungen im Hebezeugbetrieb“ (Use of load suspension devices for hoisting purposes) as issued by German Accident Prevention & Insurance Association).
- Mounting and removal must exclusively be carried out by authorized persons.

Outside the Federal Republic of Germany the specific provisions issued locally in the country where the items are used must also be observed.

3.2 Product Safety

Risk of Injury

Make sure to use lifting rings free from defects.

- Never use worn-out, bent or damaged lifting rings.
- Never make structural changes to lifting rings (e.g. by grinding, bending).



3.3 Use

Risk of Injury

Never stay under lifted loads.

- Only lift loads the weight of which is less than or equal to the carrying capacity of the suspension gear.
- Never subject lifting rings to loads higher than their specified carrying capacity or lashing force.
- Do not use force when mounting/positioning the lifting rings.
- Do not start lifting before you have made sure that the load has been correctly attached.
- Make sure nobody stands or walks under or near suspended loads.
- Never move a suspended load over persons.
- When lifting loads make sure your hands or other body parts do not come into contact with the suspension gear.
- Never cause a suspended load to swing.
- Make sure lifting rings are mounted above the load's center of gravity.
- The mounting location of the rings on the component must be suited for the forces admitted via the lifting ring to be safely absorbed without the component suffering deformation.



4 Product Description

Weld-type lifting rings TWN 0119 and TWN 0124 mainly consist of a weld-on support and a ring. The weld-on support of lifting ring TWN 124 comes with integrated spring provided for position stabilization.

THIELE lifting rings are marked with nominal carrying capacity (WLL) in tons.

This indication only applies to the lifting ring itself and not to the overall load or suspension gear used. The lifting rings are in conformity with Machinery Directive 2006/42/EG. The rings have been type tested by 'Metall-berufsgenossenschaft Nord Süd' and marked with the H-stamp.

6 Mounting

6.1 Preparation

Mount the lifting ring so that

- no areas of danger are created,
- structural parts cannot cause the suspension gear to be deflected when the load is lifted,
- the suspension gear cannot be damaged, e.g. by sharp edges.

Make sure the useful weld seam area at the component is large enough for the lifting rings to be safely attached by welding.

7 Application

7.1 Use under Normal Conditions

The ring must always be freely movable. It must not rest on or be supported by other structural parts.



7.2 Influence of Temperature

The permissible carrying capacity of the lifting rings reduces at elevated temperatures.

The reduced carrying capacity figures shown in the following table shall only apply for short-term use at the temperatures indicated.

TWN 0119, TWN 0124:

Temperature range	Remaining carrying capacity
from -20 °C to 100 °C =>	100 %
from 100 °C to 200 °C =>	85 %
from 200 °C to 250 °C =>	80 %
from 250 °C to 300 °C =>	75 %

When the rings are to be used within other temperature ranges please get in touch with the manufacturer.

7.3 Environmental Influence

In case the rings shall be used under the influence of chemicals please consult with the manufacturer.

8 Inspections

Check the lifting rings visually at regular intervals. The results of the inspection shall be entered into a register to be prepared when the lifting ring is first used.

This register includes characteristics of the ring as well as identification particulars (Statement of compliance/inspection certificate).

An inspection must be carried out at least once a year or more frequent if the rings are in heavy-duty service. After three years at the latest the rings shall be examined for cracks.

The condition of lifting ring and its components must be documented during these inspections.

When making repairs to lifting rings note down the cause of the defect and the remedial action that has been taken.

Immediately stop using lifting rings that show the following defects:

- Deformation,
- Cuts, notches, cracks, incipient cracks,
- Rings cannot freely rotate or turn,
- Rings have been heated beyond permissible limits,
- Severe corrosion,
- Wear, e.g. exceeding 10% in the ring diameter area,
- Identification marks are unreadable,

- Defective or non-conforming welds.

9 Storage

Store the lifting rings in dry space at temperatures between 0 °C and +40 °C.

10 Welding Instructions

Welding instructions relating to weld-on supports (S355 NL or similar) to be attached to C22, S235, S355 or similar components.

The following general welding instructions shall be duly followed:

- DIN EN ISO3834
- EN 1011-2
- SEW 088
- DIN 18800
- EN 15085
- DIN 15018
- DVS 0702-1 / 0711

Welding must exclusively be performed by trained and authorized personnel qualified as per EN 287.

Preweld Treatment:

The surfaces to be joined by welding shall be flat and treated so as to have a white metal finish.

Sketch:

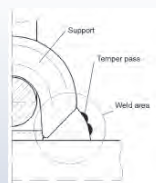

Please note also the THIELE Welding Operating Manual:

- Welding process Metal active gas welding (MAG), EN 287; No. 135
- Welding process: Manual metal arc welding (MMA), EN 287; No. 111



Miscellaneous:



1. Min. notched-bar impact strength values of ISO-V specimens KV2 = 27 J at -40 °C (e.g. S355J4G3 or S355 NL, EN10025)
2. When selecting material grades other than those listed above please contact the base material and filler metal manufacturers for information.
3. The responsible welding supervisor must make sure the welding current is correctly adjusted to suit the given welding position.

Download: www.thiele.de







Hitches

TWN 0301	Type	Bush	Article-No.	Bore	Weight approx.	
	Hitches as per DIN 74054 Part 1 and Part 2					
 	C	without	F27100	40 mm	3,7	
	A	40 mm	F27101	48 mm	3,7	

TWN 0302	Type	Bush	Article-No.	Bore	Weight approx.	
	Hitches as per DIN 74054 Part 1 and Part 2					
 	C	without	F27110	40 mm	4,0	
	A	40 mm	F27111	48 mm	4,0	



TWN 0304	Type	Bush	Article-No.	Bore	Weight approx.	
	Hitches as per DIN 74054 Part 1 and Part 2					
 	C	without	F27130	40 mm	5,1	
	A	40 mm	F27131	48 mm	5,1	

TWN 0308	Type	Bush	Article-No.	Bore	Weight approx.	
	Hitches as per DIN 74054 Part 1 and Part 2					
 	C	without	F27180	40 mm	8,5	
	A	40 mm	F27181	48 mm	8,5	
	D	without	F27182	48 mm	8,5	

Hitches

TWN 0321		Type	Bush	Article-No.	Bore	Weight approx. [kgs]
		Hitches as per DIN 74054 Part 1 and Part 2				
		C	without	F27300	40 mm	7,3
		A	40 mm	F27301	48 mm	7,3

TWN 0323		Type	Bush	Article-No.	Bore	Weight approx. [kgs]
		Hitches as per DIN 74054 Part 1 and Part 2				
		C	without	F27320	40 mm	6,4
		A	40 mm	F27321	48 mm	6,4



THIELE

App



THIELE











Lashing Products





Product Overview Lashing Products

Content **Page**

GK8 Products

	Lashing Chains GK8	147
	Round Steel Link Chains GK8 (TWN 0805)	148
	Chain Tensioners GK8 (TWN 1450, TWN 1451, TWN 1452)	149
	Hooks GK8 (TWN 0835/1)	150
	Shortening Components GK8 (TWN 0827/1)	150
	Connectors GK8 (TWN 0829)	151
	Lifting Points GK8 (TWN 0119/1, TWN 0124, TWN 1470)	151, 152
	Special Components GK8 (TWN 0869)	152

Products XL

	Lashing Chains XL	153
	Round Steel Link Chains XL (TWN 1805)	154
	Chain Tensioners XL (TWN 1454, TWN 1455)	155
	Hooks XL (TWN 1840/1)	156
	Shortening Components XL (TWN 1827/1, TWN 1852)	157 158
	Connectors XL (TWN 1829)	159
	Lifting Points XL (TWN 1880)	160
	Tensioners (TWN 1000, TWN 1001)	161

Cargo Securing with THIELE



Load securing requires measures aimed at safeguarding the load against physical forces of movement arising during transport.

Nevertheless, vehicles are encountered on our roads every day that are carrying insufficiently secured loads or loads not safeguarded at all. More often than not, changes in speed or direction produce forces causing the cargo to no longer stay in place but move irregularly on the vehicle.

To avoid this risk, every load has to be secured on the carrier irrespective of whether it is light or heavy and even when the vehicle runs at low speed. The conditions on which load securing methods are based apply to normal vehicle operation. However, „normal vehicle operation“ as a rule does not mean the carrier always travels evenly and foresightedly. Usual traffic conditions undoubtedly include full braking, uneven road surfaces, extreme evasion maneuvers and the like.

Measures implemented to secure loads must take all these conditions into account and if securing proves ineffective, insurance cover may be lost partly or even entirely. In such a case the relevant company or private person must bear the arising costs alone which may often lead to their economic ruin.

It is still not sufficiently known to all those concerned that the responsibility for load securing does not only lie with the driver of a vehicle but with all other participants in the forwarding chain as well (e.g. owner, sender, carrier, hauler etc.).



Physical Fundamentals

THIELE, expert on load securing, informs us about some physical fundamentals worth known in this respect.

In the event of an emergency braking operation of the vehicle down to zero speed deceleration rates of up to 8 m/s^2 may arise. To put it in another way, 80 % of the weight of a given cargo component has to be absorbed by means of suitable securing means to prevent the load from sliding forward.

The centrifugal forces acting transversely to the direction of travel when a vehicle passes through turns must also be taken into account in the context of cargo securing. The design of commercial vehicles permits building up rates of acceleration in the range of up to 5 m/s^2 . This means that 50 % of the cargo weight has to be secured transversely to the direction of travel.

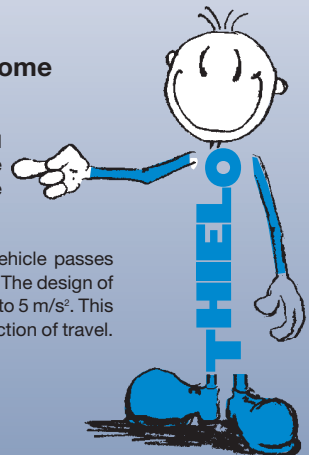



Forces Arising when Driving

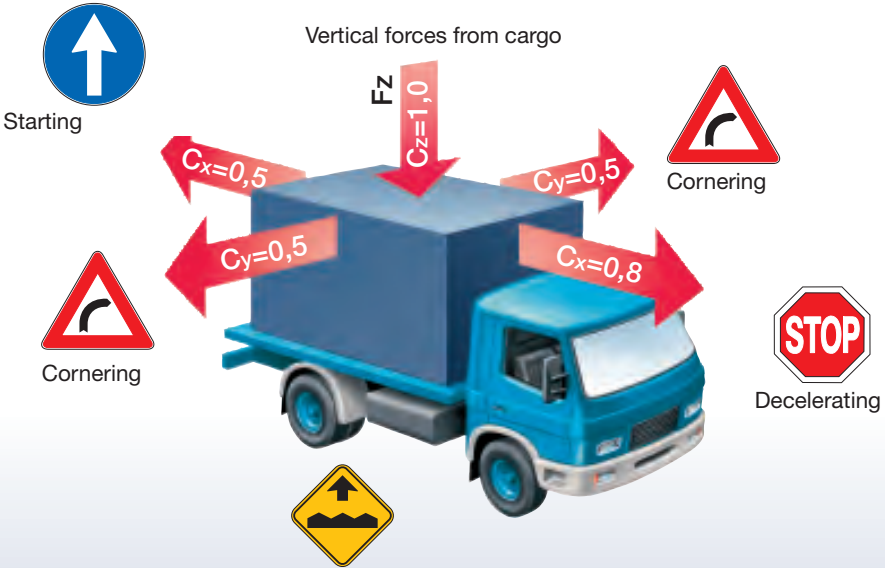

Starting

Weight forces (acceleration force) to the rear
 $0.5 \times F_z = 50\%$ of the cargo weight

Decelerating

Weight forces (deceleration force / negative acceleration) to the front
 $0.8 \times F_z = 80\%$ of the cargo weight

Cornering

Weight forces (centrifugal force) acting sideways
 $0.5 \times F_z = 50\%$ of the cargo weight

Accordingly, assuming a cargo weight F_z of $m = 15.000$ kgs, 15.000 daN will exert thrusting or pushing forces as follows:

100 %	Cargo weight	$F_z = 15.000$ daN
80 %	Longitudinal forward force of cargo	$F_x = 12.000$ daN
50 %	Transverse force of cargo to the right/left	$F_y = 7.500$ daN
50 %	Longitudinal rearward force of cargo	$F_y = 7.500$ daN

All these forces must be retained by means of load securing means or lashing devices.



Securing Methods

Basically, a distinction is to be made between force- and form-closed cargo securing.

- **Tie-down lashing** = Force closure
- **Direct lashing** = Form closure

Tie-down Lashing

The perhaps most commonly used load securing method is tie-down lashing (see Figures 1 and 2). The load securing devices are arranged over the cargo, attached to lashing fixtures and then tightened using maximum hand force.

The pre-tensioning force thus applied acts additionally to the weight force causing the cargo to be pressed onto the load area and frictional forces to increase. The sum from the weight and pressing forces takes effect in „all directions“. This in particular is the major advantage of the tie-down lashing method.

Vertical angle α primarily determines the effectiveness of the tie-down lashing method. When using a 90° angle 100% of the force introduced into the lashing system takes effect, at 30° this is only 50%. For this reason lashing angle β , should never be less than 30°.



Moreover, the following should be considered for tie-down lashing operations:

- A high degree of friction must exist between cargo and load area as well as between the individual cargo components.
- The sliding friction coefficient must be known or well assessable.
- The cargo must be capable of withstanding high pre-tensioning forces.
- The lashing points on the vehicle must be designed to take the arising loads.
- Due to settling processes the pre-tension of the load securing device must be regularly checked during transit so as to rule out that pre-tensioning forces will decrease and no longer be adequate.

The magnitude of the frictional force depends on the characteristics of the materials in contact with each other. It is clearly evident that a piece of metal will easier slide to and from a metal surface than on a surface consisting of rubber.

In practical testing on load surfaces as well as in laboratory tests a multitude of so-called sliding friction coefficients have been determined which serve as calculation basis for cargo securing purposes. These coefficients are identified by the symbol μD .

Dynamic friction coefficients of common cargo

Material pairing	Sliding friction coefficient (μD)
Steel on steel, oiled	0.10
Timber on steel plates	0.30
Steel on wood	0.40
Pre-cast concrete component with wood interlayer on wood (concrete/wood/wood)	0.40
Concrete on lattice beam	0.60

Source: DIN EN 12195-1

Table 1



Due to the lashing angles tie-down lashing requires high pre-tensioning forces.

Force introduction via the tensioning element

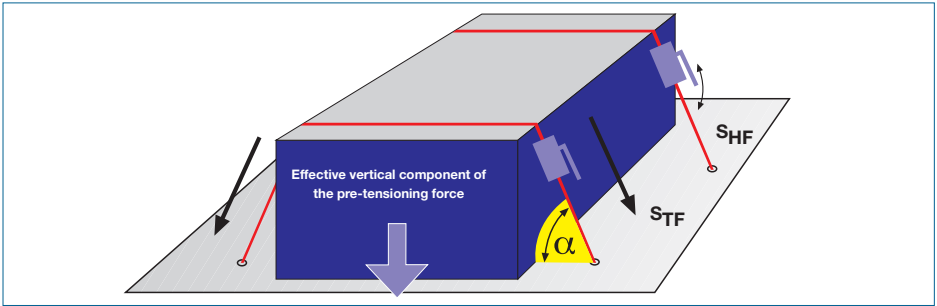

Figure 1

S_{HF} = Standard Hand Force (max. 50 daN) applied to the lever of the ratchet or screw tensioner. Only, if the tensioning element is tightened by hand (*S_{HF}*) at 50 daN can the pretensioning force (*S_{TF}*) indicated on the identification tag be reached.

S_{TF} = Standard Tension Force = Remaining force after the lever of the tensioning device has been released; i.e. the actually remaining force exerted by the load securing device.

The pre-tensioning force **F_T** is determined according to the following equation:

$$F_T \geq \frac{C_{x,y} - \mu_D}{\mu_D \times \sin \alpha} \times \frac{F_z \text{ [daN]}}{k \times n}$$

Where

C_{x,y}* = Acceleration coefficient (in travel direction *c_x* = 0.8; transversely and counter to the drive direction *c_y* = 0.5)

C_z* = Acceleration coefficient, vertical

μ_D = Dynamic friction coefficient (sliding friction coefficient)

sin = Sine function of the lashing angle

F_z = Vertical force of the cargo (cargo weight) ; (*F_z* = *m* × *g* × *c_z*)

k = Transfer coefficient (loss of pre-tensioning force due to friction between cargo and load securing device)

k = 1.5 if the load securing device is tightened by means of a tensioning device

n = number of lashing devices

* Assumption: Cargo on road trucks and trailers

Over-the-top lashing

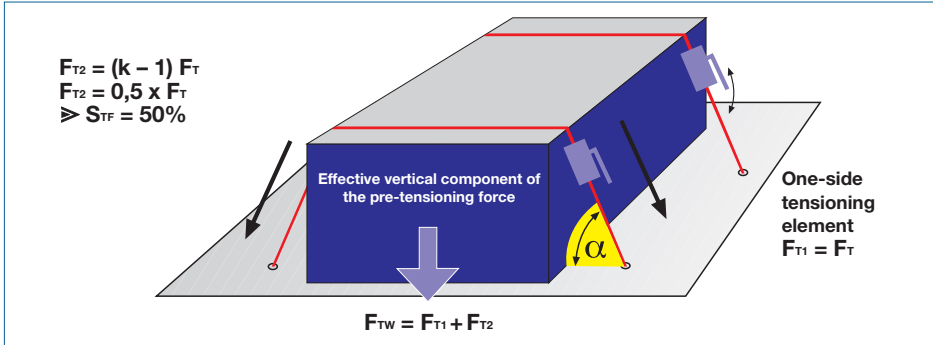

Figure 2

Table 2 provides a rough impression of the pre-tensioning forces required to safely secure cargo.



The data shown is based on material pairings listed in Table 1.

Cargo-weight (F_z) [daN]	Sliding-friction coefficient [μ_D]	Lashing angle [α]	Total-pre-tensioning force [daN]	Lashing angle [α]	Total-pre-tensioning force [daN]
2.000	0,10	50°	12185	80°	9485
	0,40	50°	1745	80°	1355
	0,60	50°	580	80°	455
10.000	0,10	50°	60925	80°	47425
	0,40	50°	8725	80°	6775
	0,60	50°	2900	80°	2275
30.000	0,10	50°	182775	80°	142275
	0,40	50°	26175	80°	20325
	0,60	50°	8700	80°	6825

Table 2

As is evident from Table 2 sliding friction coefficient and lashing angle are of great significance!

Reach your destination with cargo
safely secured!





Pre-tensioning forces

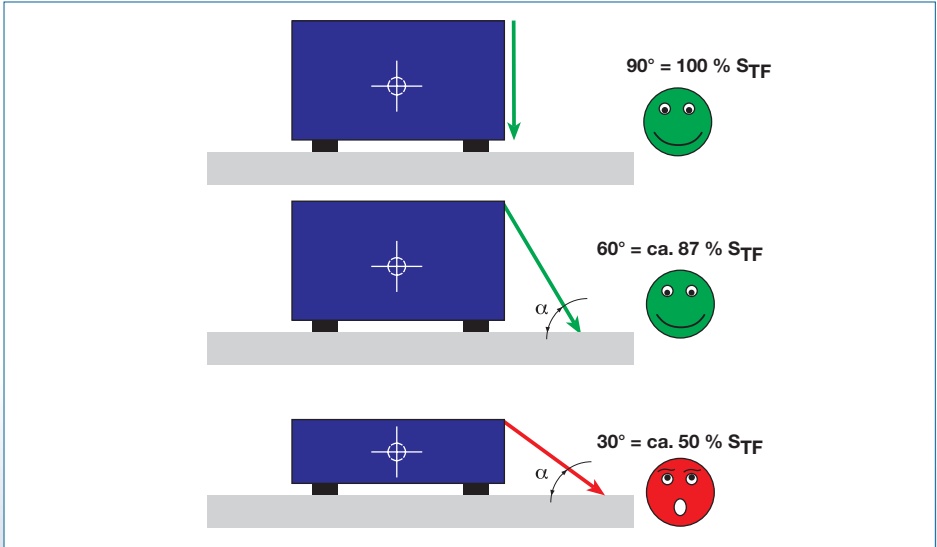

Figure 3

As is evident, significantly high pre-tensioning forces are sometimes needed and it is thus plain to see that such forces can only be applied with appropriately sized load securing device.

The most important parameters of load securing device are as follows:

Lashing capacity (LC)

Lashing Capacity in [daN] (formerly denoted permissible pull force)

Maximum force in straight legs for which a load securing device is designed for use.

Standard Tension Force (S_{TF})

S_{TF} min. = 0,25 x LC

min. = 0,15 x LC for chains of diameter = 13 and 16 mm

S_{TF} max. = 0,50 x LC

Both characteristics can be seen from the identification tag of the chain. The Standard Tension Force S_{TF} is the force that remains in the load securing device when the tensioning lever has been released, i.e. the actually remaining force exerted by the system.

To determine how many lashing elements are needed the calculated total pre-tensioning force must be divided by the standard tension force of the load securing device selected. If lashing belt systems are used a double-digit number of belts may easily be required to secure customary payloads or cargo.

This is no doubt completely unsuitable for practical purposes. However, using THIELE lashing chains may reduce the required number of tensioning means by a factor of eight. Nevertheless, it is generally recommendable that anti-slip friction-increasing mats be employed both for tie-down lashing and direct lashing jobs.



Direct Lashing

Direct lashing is a highly effective cargo securing method because it makes use of the lashing capacity of the lashing device. Since the load securing device is not pre-tensioned only little manual power is needed for tightening. The lashing element is suspended from lashing points in the load area and then attached to the cargo, all that is needed is to tighten the system by hand to prevent the chain from sagging or swinging.

The design prerequisite for a chain to be used as securing means is the lashing capacity (LC) which is thus the decisive parameter for the chain thickness as well as pertinent tensioning and connecting elements.

Diagonal lashing

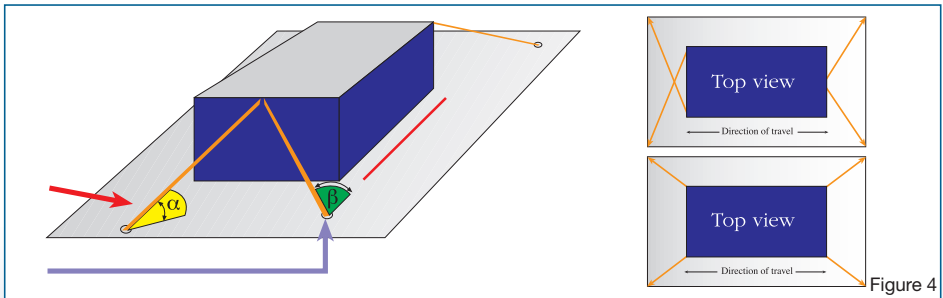

Figure 4

In this case, physical laws prescribe the limits according to which the lashing angles should be selected. Calculations show that it is expedient for horizontal angles to be in a range of between 20° and 45° because if is smaller than 20° and the friction coefficient smaller than 0.5 an additional determination of the lashing element force must be performed to safeguard against slipping during vehicle cornering. If, on the other hand, the angle is greater than 60° the lashing capacity will increase more than proportionally. Theoretically, they would even be infinitely great in the case of a 90° angle. Based on these considerations it can be said that the frequently employed diagonal/cross-wise lashing method for cargo securing in travel direction is highly unfavorable, at least in its extreme configuration (horizontal angle).

Expedient limits are to be observed also with respect to vertical angle which should not be exceeded to rule out a disproportional increase of forces acting on the lashing elements. In this case, however, the load securing device capacity is best utilized when the vertical angle ranges between 0° and 20°.

Based on the factors described above the required lashing capacity (LC) is calculated by means of the following formula:

$$LC \geq \frac{F_z \text{ [daN]} \times (c_{x,y} - \mu_D)}{(\sin \alpha \times \mu_D + \cos \alpha \times \cos \beta) \times n}$$

According to the calculation, a load securing device must be selected that has at least the same permissible lashing capacity.

Symbols used in the formula:

- LC = Lashing Capacity
 - F_z = Vertical force of the cargo (cargo weight); (F_z = m x g x c_z)
 - μ_D = Dynamic friction coefficient (sliding friction coefficient)
 - c_{x,y}* = Acceleration coefficient (in travel direction c_x = 0.8; transversely and counter to the travel direction c_y = 0.5)
 - c_z* = Acceleration coefficient, vertical
 - α = Vertical angle of the lashing legs
 - β = Horizontal angle of the lashing legs
 - n = Number of lashing chains in the respective direction
- * Assumption: Cargo on road trucks and trailers





Load securing device

Lashing chains are elements best suited for cargo securing purposes. They offer major advantages in that their working volume is known enabling cargo securing jobs to be accurately calculated.

For standard lashing chains exclusively shortlink round steel chains to DIN EN 818-2 or PAS 1061 must be employed. Longlink round steel chains are to be used for log transportation only.

In the interest of your own as well as public safety, exclusively use the shortening elements to DIN EN 1677-1 offered and approved by the chain manufacturer for the shortening of a lashing chain. When resorting to self-made makeshift shortening methods the capacity of the load securing device is no longer warranted.

When using lashing hooks care must be taken that all safety requirements according to DIN EN 1677-2 are observed (hook safeguarding).

Connecting and shortening parts must have elements preventing them from being inadvertently released/opened.

Standard and quickaction turnbuckles must be provided with (screw removal) safeguard preventing them from being inadvertently released.

Multi purpose ratchet hoists must also meet EN 13157-1998 requirements.

The complete lashing chain to DIN EN 12195-3 comprises:

- | | | |
|------------------------|---|---|
| • Load securing device | : | Round steel chain |
| • Tensioning element | : | Screw tensioner, multi purpose ratchet ratchet tensioner |
| • Connecting element | : | Hook, shackle, chain shortener, chain connector, end link |
| • Identification tag | : | Metal tag |

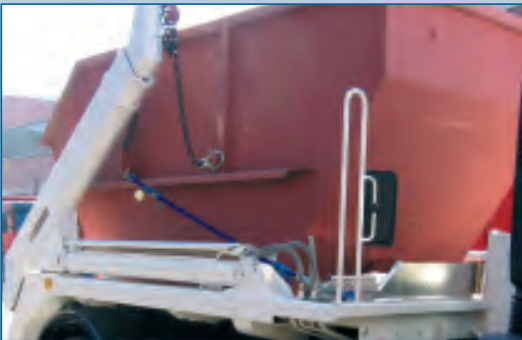



Inspection of Lashing Chains

Load securing devices are of course also subject to a certain amount of wear due to use or may become damaged when improperly used. It is thus indispensable that round steel chains as well as components are inspected at regular intervals by a qualified person to make sure they are taken out of service or repaired without delay when damaged or worn out.

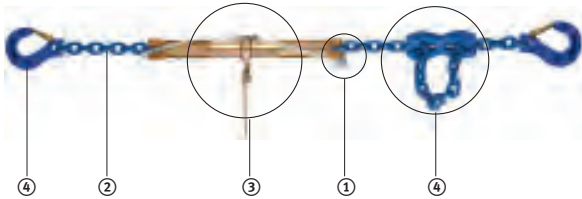

Indicators for removal from service are in particular:



1. Identification

- Tag conforming to standard
- missing or illegible tags

2. Load securing device

- Round steel chain
- Elongation of a chain link by more than 3 %
- Wear exceeding 10 % of nominal thickness
- Visible deformation
- Surface cracks

3. Tensioning elements

- Screw tensioner
- Ratchet tensioner
- Ratchet hoist
- Deformation
- Cracks
- Severe signs of wear
- Severe corrosion

4. Connecting parts

- End link
- Chain connector
- Shackle
- Shortening claw
- Shortening hook
- Lashing hook
- Deformation
- Cracks
- Severe signs of wear
- severe corrosion
- Hook widening by more than 10 %



Do NOT use...

... round steel chains

- the working load limit or lashing capacity of which is lower than Grade 8 as per DIN EN 818-2
- without manufacturer's sign/symbol

... tensioning elements

- without turn off locking mechanism
- without manufacturer's sign/symbol
- with long levers capable of producing a pre-tensioning force over $0.5 \times LC$

... shortening components or lashing hooks

- which may reduce the breaking force of the chain
- without safety latches or locking pins

Lashing Hooks / Sling Hooks

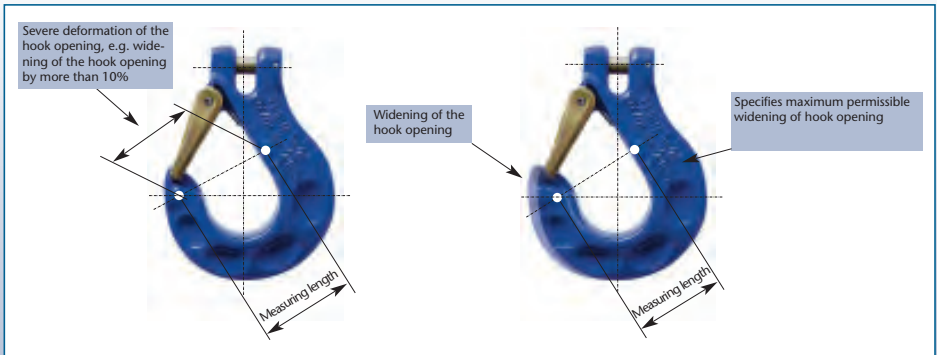

The embossed maximum permissible limit with measuring points enables hook opening width to be easily checked.

Repair work must exclusively be performed by qualified personnel. Only clearly identifiable lashing chains are allowed to be repaired.

More detailed information regarding the inspection of lashing chains are provided in the respective chain operating instructions.

For this purpose THIELE offers regular competence training via the relevant THIELE forum.



Identification / Marking

THIELE lashing chains are provided with an identification tag specifying the chain's performance characteristics. These enable the relevant chain to be clearly identified and rule out mix-up or usage mistakes. Information on the chain tag data and how to use these data are given below. The DIN EN 12195-3 prescribes which data/ characteristics must be marked on the tag.

Identification tag according to DIN EN 12195-3

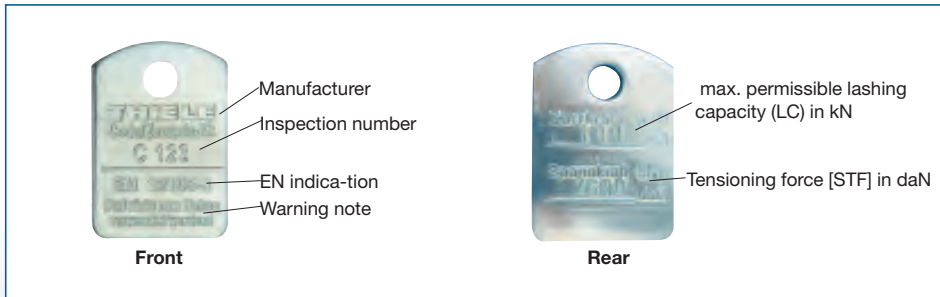

Tags as per DIN EN 12195-3 show on their front the number of the standard specification, the name of the chain manufacturer, the inspection number, as well as a warning that the chain must not be used for lifting service. On the rear side of the tag the maximum permissible lashing capacity [LC] in kN and the standard tension force STF in daN is hardstamped.

How to Use Lashing Chains

To make sure lashing chains have a long service life without wear and damage there are some aspects to be observed when handling these chains.

- Do not overload lashing chains.
- The maximum hand force of 50 daN must only be exerted with one hand. Using bars, levers or similar tools is prohibited.
- Make sure the lashing chain cannot damage the cargo and vice versa.
- For example, make use of edge protectors to prevent damage to the cargo and wear to chain and cargo.
- Never use chains with knots or chains connected by screws, bolts, studs or similar.
- To shorten chains, exclusively employ the shortening elements offered and approved by the chain manufacturer, otherwise the stability of the chain cannot be warranted.



Lashing Point ZK Module **GK8** TWN 1470

Lashing (attachments) points and elements must meet the requirements specified in DIN EN 12640. This standard specification spells out minimum needs and tests for lashing points on road trucks and trailers with flatbed bodies and a permissible GVW of more than 3.5 t which are meant for mixed cargo transportation.

Lashing points in this context are attachment devices/arrangements on a vehicle to which a load securing device can be directly fastened. A lashing point may, for example, be designed as an oval link, hook, and eyelet or lashing rail. It is in this technical context that problems are most frequently noticed in practice. An inexpert sizing and use of unsuitable lashing points may not only cause damage to the lashing point itself and the vehicle frame but also create very serious hazards to road traffic and safety.



Suspension element

If a lashing design includes a suspension link, unforeseeable bending moments are often encountered which may result in damage to the lashing point and car body. More often than not, the arising angles are left out of consideration. Moreover, if not in use the suspension links lead to unnecessary noise pollution when the vehicle is on the road.

The ZK module (lashing ring with cassette) newly developed by THIELE can be attached most easily and safely to the lateral frame of trailers. The lashing rings are made of the same steel material as is used for the manufacture of the lashing chains. THIELE's ZK module has also been approved by the TÜV inspections agency and corresponds to European standard DIN EN 12640; it has 100 % load capacity in all pulling directions. The lashing ring offers a 150° swivel range and enables cargo of low height as well as load items projecting over the load area to be safely secured. Furthermore, the lashing ring can be folded away thus preventing accidents when people move on the cargo platform.

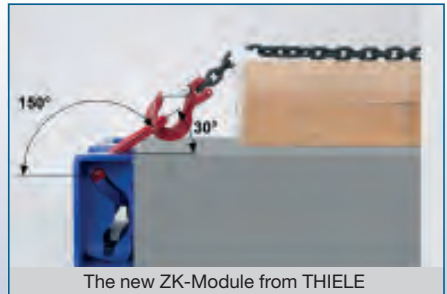

The new ZK-Module from THIELE

Application examples:



ZK-Module



The lashing ring is marked with permissible lashing capacity, manufacturer's sign and DIN EN number so that official agencies are able to check its correct installation locally. The ZK module manufactured by THIELE provides maximum safety for cargo securing and is thus highly instrumental in road traffic safety.



Products for Securing of Loads

Lashing Chain **GK8** with Tensioner according to DIN EN 12195-3)

TWN 1400



Standard length L = 3.500 mm, with opened tensioner, not shortened. All lengths available upon request. The adjustment will be reached by the shortening device and the tensioner.

Trade Size	Art.-No.	Nominal Size [mm]	Maximum Lashing Force under Straight Load		Weight app. [kgs]
			[daN]		
8-8	F34171	8	4.000		8,50
10-8	F34172	10	6.300		12,50
13-8	F34173	13	10.000		21,00
16-8	F34174	16	16.000		37,70



Lashing Chain **GK8** with Ratchet (according to DIN EN 12195-3)

TWN 1401



Standard length L = 3.500 mm, with opened tensioner, not shortened. All lengths available upon request. The adjustment will be reached by the shortening device and the tensioner.

Trade Size	Art.-No.	Nominal Size [mm]	Maximum Lashing Force under Straight Load		Weight app. [kgs]
			[daN]		
8-8	F34171R	8	4.000		8,50
10-8	F34172R	10	6.300		12,50
13-8	F34173R	13	10.000		21,00

Identification tag **GK8** according to EN 12195-3

for lashing chains

Article No. Z07264

TWN 1402



Round Steel Link Chains **GK8** TWN 0805

Reduced Safe Working Load of Round Steel Link Chains

If Grade 80 - Alloy Slings are used at temperatures exceeding 200°C, then the Working Load Limit has to be reduced acc. to Table 4.

Table 4: Temperature

Safe Working Load indicated in % acc. to Tables 1, 2 or 3 by chain temperatures of:

- 40 to + 200°C	over 200 to 300°C	over 300 to 400°C
100	90	75

Before using the Alloy Slings at temperatures below - 40°C, the manufacturer has to be consulted.

Table 5: Asymmetry

No. of legs	1	2	3	4			
Inclination β max.	-	0° - 45°	46° - 60°	0° - 45°	46° - 60°	0° - 45°	46° - 60°
Load factor	1	1	1	1,4	1	1,4	1



Trade Size	Art.-No.			Nominal Size		Pitch		Inside width [w ₁] min.	Outside width [w ₂] max.	Working Load Limit [t]	Weight app. [kg/m]
	self- coloured	RAL 9005	corrothiel	[d]	Abw./ tol. ±	[p]	Abw./ tol. ±				
6-8	F01452	F01453	F01454	6,00	0,24	18,00	0,5	7,80	22,20	1,12	0,8
7-8	F01458	F01459	F01457	7,20	0,20	21,80	0,6	9,45	25,20	1,50	1,1
8-8	F01464	F01465**	F01429	8,00	0,32	24,00	0,7	10,40	29,60	2,00	1,4
10-8	F01469	F01470**	F01450	10,00	0,40	30,00	0,9	13,00	37,00	3,15	2,2
13-8	F01474	F01475**	F01476	13,00	0,52	39,00	1,2	16,90	48,10	5,30	3,8
16-8	F01479	F01580	F01487	16,00	0,64	48,00	1,4	20,80	59,20	8,00	5,7
18-8	F01484	F01485	F04580	18,00	0,90	54,00	1,6	23,40	66,60	10,00	7,3
20-8	F01494	F01495	F04606	20,00	1,00	60,00	1,8	26,00	74,00	12,50	9,0
22-8	F01499	F01500	F04629	22,00	1,10	66,00	2,0	28,60	81,40	15,00	10,9
26-8	F01514	F01515	F04695	26,00	1,30	78,00	2,3	33,80	96,20	21,20	15,2
28-8*	F01519	F01520	F01521	28,00	1,40	84,00	2,5	36,40	104,00	25,00	17,6
32-8	F01524	F01525	F01526	32,00	1,60	96,00	2,9	41,60	118,00	31,50	23,0
36-8	F01529	F01530	F04814	36,00	1,80	108,00	3,0	46,80	133,00	40,00	29,0
40-8*	F01534	F01535	F04838	40,00	2,00	120,00	4,0	52,00	148,00	50,00	36,0
45-8*	F01539	F01540	F04889	45,00	2,30	135,00	4,0	58,50	167,00	63,00	45,5
50-8*	F01545	F01546	F04900	50,00	2,50	150,00	4,5	67,50	180,00	80,00	56,0
56-8*	F01555	F01556	F04908	56,00	2,80	170,00	5,0	75,60	201,60	100,00	72,5
63-8*	-	F01566	-	63,00	3,20	190,00	6,0	88,00	230,00	125,00	89,0

* These sling chains are only available in welded finish

**TOP-Articles (see page 13)

Elongation at break, self coloured, min. 25%; bright finished min 20%.

Factor "Working Load Limit" : Proof Force = Breaking Force = 1 : 2,5 : 4 (200 : 500 : 800 N/mm²)



Chain Tensioners **GK8**

Trade Size	Art.-No.	Nominal Size [mm]	norm. straight load (S_{T7}) [daN] min.	tensioner under straight load [daN] max.	Dimensions [mm]			Weight approx. [kgs]	TWN 1450 GK8
					E_{max}	E_{min}	stroke		
8-8	F34179	8	1.800	4.000	345	270	75	2,10	 <p>Chain Tensioner acc. to DIN EN 12195-3</p>
10-8	F34199	10	2.200	6.300	375	275	100	2,70	
13-8	F34189	13	2.600	10.000	460	340	120	4,00	
can be also used in slings									

Trade Size	Art.-No.	Nominal Size [mm]	norm. straight load (S_{T7}) [daN] min.	tensioner under straight load [daN] max.	Dimensions [mm]			Weight approx. [kgs]	TWN 1451 GK8
					E_{max}	E_{min}	stroke		
8-8	F34175	8	1.800	4.000	345	270	75	2,50	 <p>Chain Tensioner acc. to DIN EN 12195-3</p>
10-8	F34195	10	2.200	6.300	375	275	100	3,50	
13-8	F34185	13	2.600	10.000	460	340	120	5,00	
can be also used in slings									



Trade Size	Art.-No.	Nominal Size [mm]	norm. straight load (S_{T7}) [daN] min.	tensioner under straight load [daN] max.	Dimensions [mm]			Weight approx. [kgs]	TWN 1452 GK8
					E_{max}	E_{min}	stroke		
13-8	F341871	13	2.600	10.000	675	445	230	7,20	 <p>Chain Tensioner acc. to DIN EN 12195-3</p>
16-8	F34197	16	3.100	16.000	835	555	280	11,80	
can be also used in slings									



Hooks GK8

Trade Size	Art.-No.	Nominal Size [mm]	Working Load Limit [t]	Dimensions [mm]								Weight app. [kgs]	
				E	G	H	C						
6-8	F33601	6	1,12	75	23	17	16						TWN 0835/1 GK8  Sling Hook with Clevis and Safety Latch
8-8	F33611	8	2,00	99	30	22	22						
10-8	F33621	10	3,15	121	38	29	28						
13-8	F33631	13	5,30	143	44	37	36						
16-8	F33641	16	8,00	175	54	45	43						
18-8	F33651	18	10,00	195	60	52	50						
20-8	F33656	20	12,50	220	65	58	55						
22-8	F33661	22	15,00	244	75	64	61						

Shortening Components GK8

Trade Size	Art.-No.	Nominal Size [mm]	Working Load Limit [t]	Dimensions [mm]								Weight app. [kgs]
				E	G	L	B					
8-8	F33200	8	2,00	61	9	101	61					TWN 0827 GK8  Shortening or Grab Hook Cradle Type with Pin Coupling
10-8	F33210	10	3,15	73	12	125	75					
13-8	F33220	13	5,30	95	15	160	95					
16-8	F33230	16	8,00	112	18	188	120					
20-8	F33245	20	12,50	148	22,5	242	141					
with extra wide chain bed												

Trade Size	Art.-No.	Nominal Size [mm]	Working Load Limit [t]	Dimensions [mm]								Weight app. [kgs]
				E	G	L	B					
8-8	F33201	8	2,00	61	9	101	61					TWN 0827/1 GK8  Shortening or Grab Hook Cradle Type with Pin Coupling and Safety Device
10-8	F33211	10	3,15	73	12	125	75					
13-8	F33221	13	5,30	95	15	160	95					
16-8	F33231	16	8,00	112	18	188	120					
20-8	F33246	20	12,50	148	22,5	242	141					
with extra wide chain bed												

Connectors **GK8**

Trade Size	Art.-No.	Nominal Size [mm]	Working Load Limit [t]	Dimensions [mm]						Weight app. [kgs]	TWN 0829 GK8
				E	G	A	C	F			
6-8	F30000	6	1,12	43	17	59	45	7,5		0,07	
7-8	F30005	7	1,50	56	17	75	47	9		0,16	
8-8	F30810*	8	2,00	60	18	79	50	10		0,19	
10-8	F30820*	10	3,15	75	22	99	63	12		0,35	
13-8	F30830*	13	5,30	98	28	128	80	15		0,73	
16-8	F30840	16	8,00	110	33	148	98	19		1,38	
18-8	F30850	18	10,00	122	36	165	110	22		1,86	
20-8	F30855	20	12,50	134	45	185	122	26		2,34	
22-8	F30860	22	15,00	145	46	198	132	26		3,16	
26-8	F30870	26	21,20	164	55	225	156	30		5,00	
32-8	F30880	32	31,50	192	65	268	192	37		9,33	

*TOP-Article (see page 13)



THI-LOK®

Lifting Points **GK8**

Trade Size	Art.-No.	Working Load Limit [t]	Lashing Capacity (LC)[daN]	Marking DSK-N	Dimensions [mm]								Weight approx. [kgs]	TWN 0119 GK8
					E*	F*	C	L	H	D	B			
6-8	F35103	1,12	2.200	1	59	31	32	32	28	12	36	0,24		
8-8	F35113	2,00	4.000	2	69	37	38	38	33	14	42	0,46		
10-8	F35123	3,15	6.300	3	84	46	45	44	38	18	48	0,63		
13-8	F35133	5,30	10.000	5	120	69	60	60	51	24	66	1,90		
16-8	F35143	8,00	16.000	8	127	66	68	65	61	28	72	2,67		
22-8	F35163	15,00		15	178	98	96	109	80	39	120	8,09		
32-8	F35183	31,50		32	292	174	145	165	118	56	180	27,30		
40-8	F35193	50,00		50	371	228	186	210	145	72	230	60,00		

* E- and F-Dimension vertical to the welding level



Lifting Point
welded type

Trade Size	Art.-No.	Working Load Limit [t]	Lashing Capacity (LC)[daN]	Marking DSK-N	Dimensions [mm]								Weight approx. [kgs]	TWN 0124 GK8
					E*	F*	C	L	H	D	B			
6-8	F35107	1,12	2.200	1	56	30	32	32	28	12	36	0,25		
8-8	F35110	2,00	4.000	2	67	37	38	38	33	14	42	0,43		
10-8	F35124	3,15	6.300	3	81	45	45	44	38	18	48	0,72		
13-8	F35139	5,30	10.000	5	117	69	60	60	51	24	66	1,90		
16-8	F35144	8,00	16.000	8	122	67	68	65	61	28	72	2,80		

* E- and F-Dimension vertical to the welding level



Lifting Point
welded type, with spring



Lifting Points **GK8**

Nominal Size	Art. No	Lashing Capacity (LC) [daN]	Dimensions [mm]							Weight approx. [kgs]	TWN 1470 GK8
			A	B	C	D	E	T*			
5	F35236	5.000	107	12	144	72	50	14	2,60		
10	F35237	10.000	137	15	144	72	60	18	3,60		
										*Eyelet thickness	

Special Lifting Points **GK8**

Trade Size	Art.-No.	Nominal Size [mm]	Working Load Limit [t]	Dimensions [mm]							Weight approx. [kgs]	TWN 0869 GK8
				E*	F*	C	L	H	D	B		
13-8	F31380	13	5,30	141	57	65	125				1,80	
16-8	F31385	16	8,00	148	57	65	127				2,60	
Skip Suspension Link with Pin Coupling and forged Safety Latch												



Lashing Chains XL

Lashing Chain XL with Tensioner (according to DIN EN 12195-3)

TWN 1410



Standard length L = 3.500 mm, with opened tensioner, not shortened. All lengths available upon request.
The adjustment will be reached by the shortening device and the tensioner.

Trade Size	Art.-No.	Nominal Size [mm]	Maximum Lashing Force Under Straight Load		Weight approx. [kgs]
			[daN]		
13-XL	F34183	13	13.400		21,63
16-XL	F34184	16	20.000		39,55



Lashing chain XL with Ratchet (according to DIN EN 12195-3)

TWN 1411



Standard length L = 3.500 mm, with opened tensioner, not shortened. All lengths available upon request.
The adjustment will be reached by the shortening device and the tensioner.

Trade Size	Art.-No.	Nominal Size [mm]	Maximum Lashing Force Under Straight Load		Weight approx. [kgs]
			[daN]		
13-XL	F34183R	13	13.400		22,83
16-XL	F34184R	16	20.000		41,05

Tensioning Tag XL TWN 1402 according to EN 12195-3

for Lashing Chains

Article-No. Z07264 (EN 12195-3)





Round Steel Link Chains TWN 1805 acc. to PAS 1061 XL-400

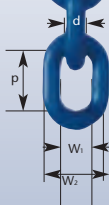

Trade Size	6-XL	8-XL	10-XL	13-XL	16-XL	20-XL	22-XL	26-XL
Art.No.	F01610B	F01615B	F01622B	F01629B	F01635B	F01638B	F01650B	F01660B
Nominal Size (d)	6	8	10	13	16	20	22	26
Pitch (p)	18	24	30	39	48	60	66	78
Pitch Tolerance (±)	0,5	0,7	0,9	1,2	1,4	1,8	2,0	2,3
Inside Width w ₁ min.	7,8	10,92	13,0	17,48	20,8	26,0	28,6	33,8
Outside Width w ₂ max.	22,2	29,6	37,0	48,1	59,2	74,0	81,4	96,2
Working Load Limit (t)	1,4	2,5	4,0	6,7	10,0	16,0	19,0	26,5
Weight approx (kg/m)	0,9	1,6	2,5	4,3	6,5	10,1	12,3	17,1





Chain Tensioners XL

The **Chain Tensioner XL TWN 1454** is in accordance with standard EN 12195-3 and EN1677-1. Together with other lashing- and connecting components they are basically used in Lashing Chains according to EN 12195-3 for securing of loads in all industry sectors. Additionally, they are suitable for overhead lifting purposes.

The Tensioners achieve a high pre-tension force with less effort because of the screw transmission. This feature is important for tying down because only the pretension force is contributing to the securing of loads.

Further advantages can also be mentioned:

- ⊕ A practical dimensioned tensioning hub
- ⊕ Protected screw spindle located inside
- ⊕ Robust protection tubes
- ⊕ Integrated turn off locking mechanism
- ⊕ Clevis type connection on both ends allows easy assembly of the corresponding round steel link chain.
- ⊕ Handle is dimensioned according to EN 12195-3 (ergonomic aspect: Maximum hand pulling force is limited to 500N)
- ⊕ Finish: electro galvanized and yellow chromated

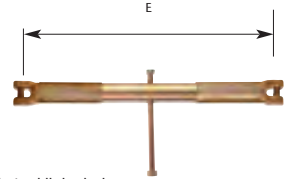

Trade Size	Article-No.	Nominal Size [mm]	norm. straight load (S _{tr}) daN min.	tensioner under straight load max. in [kN]	Dimensions [mm]			Weight approx. [kgs]
					E _{max}	E _{min}	stroke	
13-XL	F341877	13	2.600	130	675	445	230	7,20
16-XL	F341977	16	3.100	200	834	554	280	11,80



suitable for lifting

The **Chain Tensioner XL TWN 1455** is in accordance with standard EN 12195-3 and EN1677-1. Together with other lashing- and connecting components they are basically used in Lashing Chains according to EN 12195-3 for securing of loads in all industry sectors. Additionally, they are suitable for overhead lifting purposes.

The Ratchet Tensioners achieve a high pre-tension force with less effort because of the screw transmission. This feature is important for tying down because only the pretension force is contributing to the securing of loads.

Further advantages can also be mentioned:

- ⊕ A practical dimensioned tensioning hub
- ⊕ Protected screw spindle located inside
- ⊕ Robust protection tubes
- ⊕ Integrated turn off locking mechanism
- ⊕ Clevis type connection on both ends allows easy assembly of the corresponding round steel link chain.
- ⊕ Handle is dimensioned according to EN 12195-3 (ergonomic aspect: Maximum hand pulling force is limited to 500N)
- ⊕ **In case of regular greasing, the operational life span of the lever block can be increased considerably. Please use designated grease nipple.**
- ⊕ Finish: electro galvanized and yellow chromated

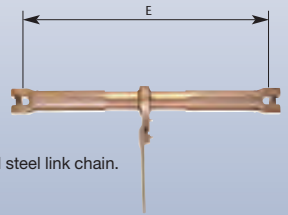

Trade Size	Article-No.	Nominal Size [mm]	norm. straight load (S _{tr}) daN min.	tensioner under straight load max. in [kN]	Dimensions [mm]			Weight approx. [kgs]
					E _{max}	E _{min}	stroke	
13-XL	F341878	13	2.600	130	675	445	230	8,40
16-XL	F341978	16	3.100	200	834	554	280	13,50

suitable for lifting



Hooks XL

New

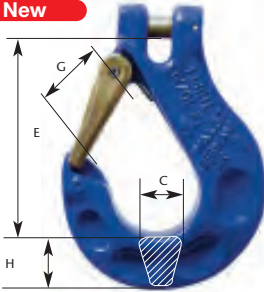

The **Clevis Sling Hook XL TWN1840/1** with its robust forged Safety Latch and its clevis is designed to the corresponding nominal size.

The onforged measurement points and maximum admissible values allows an easy check of the hook opening.

The Safety Latch is protected by a wear edge of the hook body. Additionally the safety latch has a fixed position due to the forged seat at the tip of the hook. The shape makes the Original of THIELE unique.

100% Magnetic Crack Tested. BG-approved.

Finish: RAL 5002

Lift it in »Style«

Trade Size	Article-No.	Nominal Size [mm]	Working Load Limit [t max]	Dimensions [mm]				Weight approx. [kgs]
				E	G	H	C	
6-XL	F336050	6	1,40	75	24	20	17	0,36
8-XL	F336150	8	2,50	92	30	25	22	0,75
10-XL	F336250	10	4,00	113	37	32	28	1,40
13-XL	F336350	13	6,70	133	42	41	35	2,50
16-XL	F336450	16	10,00	162	51	50	41	4,40





Shortening Components XL

The **Shortening Hook XL TWN1827/1** makes the lifting of loads even safer. The new shape of the Shortening Hook TWN 1827/1 offers you much more safety than with conventional shortenings. The extra wide chain attachment enables us to guarantee you an especially firm seating of the inserted chain link and it is also protected from damage at the same time. The locking pin prevents an accidental loosening of the sling chain.

With our new TWN 1827/1 shortening hook, we are offering you grade 10 perfection together with a long shelf life of your slinging equipment.

100% Magnetic Crack Tested. BG-approved.

Finish: RAL 5002

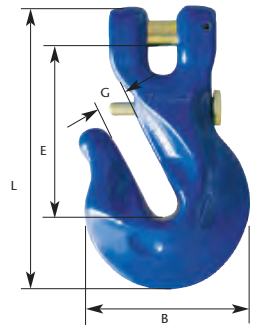

Lift it in »Style«



Trade Size	Article-No.	Nominal Size [mm]	Working Load Limit [t max]	Dimensions [mm]					Weight approx. [kgs]
				E	G	L	B		
6-XL	F33195	6	1,40	-	-	-	-	-	-
8-XL	F33205	8	2,50	58	9,5	100	60	34	0,49
10-XL	F33215	10	4,00	72	12	124	75	42	0,95
13-XL	F33225	13	6,70	93	15	158	95	54	1,86
16-XL	F33235	16	10,00	-	-	-	-	-	-





Shortening Components **XL**

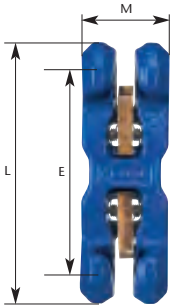

The **RAPID Shortening Claw XL TWN1852** can be assembled and disassembled fast and easily with no additional tools. The ergonomic and compact design enables its positioning at any place on the chain.

Two robust locking devices avoid the unsafe release of the chain in a loaded or unloaded condition. The locking device is equipped with a robust spring system.

100% Magnetic Crack Tested. BG - approved.

Finish: RAL 5002

Trade Size	Article-No.	Nominal Size [mm]	Working Load Limit [t max]	Dimensions [mm]			Weight approx. [kgs]
				E	L	M	
6-XL*	F34765	6	1,4	-	-	-	-
8-XL	F34775	8	2,5	111	148	48	0,79
10-XL	F34780	10	4,0	134	180	60	1,50
13-XL	F34785	13	6,7	179	240	78	2,70
16-XL	F34790	16	10,0	222	296	96	4,80

*In development

Side view



The RAPID way!

Backside



RAPID mounted



Flyer RAPID



Connectors XL

The Connector XL LOK® TWN 1829

consists of two lok halves, which enables the assembly of Round Steel Link Chains, or various components and lifting points to each other. The lok halves are interchangeable. The assembly do not requires the expensive bush.

The assembly will be completed with two locking spirol pins according to the assembling instruction as shown below.

The shape makes the Original of THIELE unique.

100% Magnetic Crack Tested. BG - approved.

Finish: electro galvanized and yellow chromated

New

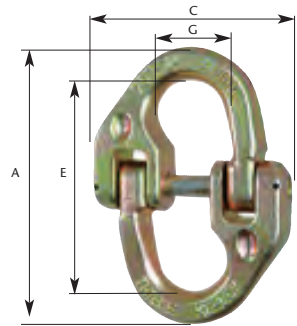

Lift it in »Style«

Trade Size	Article-No.	Nominal Size [mm]	Working Load Limit [t max]	Dimensions [mm]				Weight approx. [kgs]
				E	G	A	C	
6-XL	F30801	6	1,40	45	14	60	51	0,10
8-XL	F30811	8	2,50	60	18	80	63	0,27
10-XL	F30821	10	4,00	75	22	100	76	0,45
13-XL	F30831	13	6,70	98	28	131	93	1,00
16-XL	F30841	16	10,00	110	33	151	114	1,38



XL -LOK® Assembly instruction

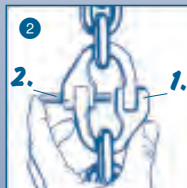
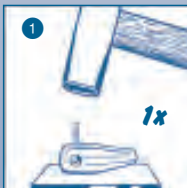



Lifting Points XL

New



Welded Lashing Point XL with spring TWN 1880

A perfect interaction between compactness and easier handling. The small size of the TWN 1880 lashing point was at the focus during the development of this weld-on lashing point. The high working load limit/lashing capacity when compared with its compact design is what makes the lashing point something special. It can be swivelled by 180°.

100% Magnetic Crack Tested

Finish: RAL 5002



Trade Size	Article-No.	Nominal Size [mm]	Lashing Capacity [LC]	Dimensions [mm]						Weight app. [kgs]
				D	B	A	E*	H	C	
6-XL	F35204	6	3.000	14	38	65	42	25	49	0,42
8-XL	F35205	8	5.000	15	45	76	45	27	50	0,57
10-XL	F35206	10	8.000	17	50	85	57	31	55	0,85
13-XL	F35207	13	13.500	23	68	116	79	44	77	2,20
16-XL	F35208	16	20.000	27	69	130	72	54	92	3,35

* upright standing ring



Tensioners

Our **TM Ratchet Tensioners** with overload protection can be operated with minimum effort. They are provided with a galvanized and yellow-chromated stainless steel chain. All models are type-tested and approved by TÜV Rheinland.

Properties:

- ⊕ with overload protection*
- ⊕ robust steel construction of lightweight design
- ⊕ alloy steel chain to EN818-7, protected against corrosion by galvanizing and yellow chromate top coat
- ⊕ low overall height
- ⊕ effortless and simple to operate
- ⊕ load hook with robust, cast safety latches
- ⊕ bottom load hook easily swiveled in ball bearing
- ⊕ suited for lashing as per DIN EN 12195
- ⊕ enclosed gearbox
- ⊕ protected, automatic brake with unique double pawl
- ⊕ durable stove-enameling
- ⊕ spares available from stock
- ⊕ TÜV / GS approval
- ⊕ test certificate, and operating manual in 7 languages
- ⊕ approved for mining operations to ATEX/68+69 (PN-EN 13463-1:2003)

* Except for TM-LB 250 kg



TM Ratchet Tensioner

Working Load Limit Capacity / Lashing Capacity	250 kg*	0,75 tons	1,5 tons	3,0 tons	6,0 tons
Artikel No.	F06190	F06241	F06251	F06261	F06271
Article No. for special lengths	F06194	F06245	F06255	F06265	F06275
Nominal length, standard	1,5 m	1,5 m	1,5 m	1,5 m	1,5 m
Chain legs	1	1	1	1	2
Force for max. working load limit	2,5 kgs	14 kgs	22 kgs	32 kgs	34 kgs
Net weight	1,8 kgs	7 kgs	11 kgs	21 kgs	31 kgs
Load chain diameter	4 mm	6 mm	8 mm	10 mm	10 mm



Notes



THIELE

App



THIELE



Hoist Chains





Fine Tolerance Hoist Chains acc. to EN 818-7



THIELE Hoist Chains according to EN818-7 (fulfil also DSKN 726300) are manufactured on modern digital controlled production lines. The high dimension accuracy enable particularly at high performance hoists a faultless run of the chain over the sprocket. The heat treatment is being done in modern and environmental friendly continuous heat treatment facilities. Therefore **THIELE** hoist chains have a homogenous high tensile strength with an exceeding core ductility along the legs and rounding of each link.

THIELE Hoist Chains are offered in the quality T and DAT.

Hoist Chains of the quality T are being used preferable in hand hoist and lever blocks. The execution DAT is mainly used in power driven hoist application. The surface is available optional in bright polished or with galvanized finish.

At electro galvanized chains **THIELE** grants due to a special developed manufacturing process and a strong quality control, a high degree of safety against brittle fracture.



Advantages at a glance:

- + Fine tolerance dimension
- + High and homogen tensile strength
- + Excellent core ductility
- + High safety against hydrogen embrittlement (at electro galvanized chains)

Article Numbers

Dimension	Article-No. Type T ¹⁾			Article-No. Type DAT ²⁾			Weight app. [kgs]
	bright	el. galvanized	el. galv.+yellow chr.	bright	el. galvanized	el. galv.+yellow chr.	
4 x 12	-	-	F09002	-	F09008	F09009	0,35
4,2 x 12,2	-	-	-	-	-	F09014	0,39
5 x 15	-	F09016	-	-	F09018	F09019	0,55
5,3 x 15,2	-	-	-	-	-	F09024	0,63
6 x 18	-	F09026	F09027	-	F09028	F09029	0,79
7 x 21 ¹⁾	F09030	F09031	-	-	F09033	F09034	1,08
7 x 22	-	F09036	-	-	F09038	F09039	1,06
7,4 x 21,2	-	-	-	-	-	F09044	1,23
8 x 24	-	F09046	F09047	-	F09048	F09049	1,41
9 x 27 ¹⁾	F09050	F09051	-	-	F09053	F09054	1,79
10 x 30	-	F09056	F09057	-	F09058	F09059	2,21
11 x 31 ¹⁾	F09060	F09061	F09062	-	F09063	F09064	2,75
13 x 36 ¹⁾	F09065	F09066	-	-	-	-	3,87
16 x 45 ¹⁾	F09070	F09071	-	-	-	-	5,82
18 x 50	F09075	F09076	-	-	-	-	7,40
22 x 66 ¹⁾	F09080	F09081	-	-	-	-	10,70
31,5 x 90 ¹⁾²⁾	F09085	F09086	-	-	-	-	22,40

Calibrated hand chain, el. galvanized

Dimension	Article-No. Type T ¹⁾			Article-No. Type DAT ²⁾			Weight app. [kgs]
	bright	el. galvanized	el. galv.+yellow chr.	bright	el. galvanized	el. galv.+yellow chr.	
5 x 25	-	Z02655	-	-	-	-	0,46



Technical Properties

Dimension	Nominal Size		Pitch		Width		Multi Pitch Length	
	d	tol. ±	p	tol. ±	w ₃ min.	w ₂ max.	11 x p _n	tol.
4 x 12	4,0	0,2	12,0	+0,15 / -0,1	4,8	13,6	132,0	+0,4 / -0,2
4,2 x 12,2	4,2	+0,1 / -0,2	12,2	+0,15 / -0,1	4,8	13,7	134,2	+0,4 / -0,2
5 x 15	5,0	0,2	15,0	+0,2 / -0,1	6,0	17,0	165,0	+0,5 / -0,3
5,3 x 15,2	5,3	+0,1 / -0,2	15,2	+0,2 / -0,1	5,9	16,9	167,2	+0,5 / -0,3
6 x 18	6,0	0,2	18,0	+0,25 / -0,1	7,2	20,4	198,0	+0,6 / -0,3
7 x 21 ¹⁾	7,0	+0,1 / -0,28	21,0	+0,3 / 0	8,4	23,4	231,0	+0,7 / 0
7 x 22	7,0	0,3	22,0	+0,3 / -0,15	8,4	23,8	242,0	+0,8 / -0,4
7,4 x 21,2	7,4	+0,1 / -0,3	21,2	+0,3 / -0,15	8,4	23,8	233,2	+1,7 / +0,7
8 x 24	8,0	0,3	24,0	+0,3 / -0,15	10,2	27,2	264,0	+0,8 / -0,4
9 x 27 ¹⁾	9,0	+0,1 / -0,4	27,0	+0,25 / -0,1	10,8	30,4	297,0	+0,7 / -0,3
10 x 30	10,0	0,4	30,0	+0,4 / -0,2	12,0	34,0	330,0	+1,0 / -0,5
11 x 31 ¹⁾	11,0	+0,3 / -0,4	31,0	+0,3 / -0,15	13,2	36,5	341,0	+0,9 / -0,3
13 x 36 ¹⁾	13,0	+0,1 / -0,5	36,0	+0,35 / -0,15	15,2	42,9	396,0	+1,1 / -0,2
16 x 45 ¹⁾	16,0	+0,3 / -0,6	45,0	+0,45 / -0,25	18,2	52,8	495,0	+1,4 / -0,5
18 x 50	18,0	0,9	50,0	+0,65 / -0,35	21,6	61,2	550,0	+1,75 / -0,85
22 x 66 ¹⁾	22,0	+0,8 / -1,1	66,0	+0,65 / -0,35	27,0	75,0	726,0	+2,0 / -0,7
31,5 x 90 ¹⁾²⁾	31,5	1,6	90,0	+1,2 / -0,6	37,8	107,1	990,0	+3,2 / -1,6



Technical Datas

Working Load Limit Table

Trade Size	Type T ¹⁾		Type DAT ^{3,4)}		Test Force MPF min. [kN]	Breaking Force [kN]
	Working L.L. [t]	Surface Hardness min.	Working L.L. [t]	Surface Hardness min.		
4 x 12	0,5	360, HV 5	0,4	500, HV 5	12,6	20,1
4,2 x 12,2	-	-	0,45	500, HV 5	13,9	22,0
5 x 15	0,8	360, HV 5	0,63	500, HV 5	19,6	31,4
5,3 x 15,2	-	-	0,72	500, HV 5	22,1	36,0
6 x 18	1,1	360, HV 5	0,9	500, HV 5	28,3	45,2
7 x 21 ¹⁾	1,5	360, HV 10	-	-	38,5	61,6
7 x 22	1,5	360, HV 10	1,2	500, HV 10	38,5	61,6
7,4 x 21,2	-	-	1,4	500, HV 10	43,0	69,0
8 x 24	2,0	360, HV 10	1,6	500, HV 10	50,3	80,4
9 x 27 ¹⁾	2,5	360, HV 10	2,0	500, HV 10	63,6	102,0
10 x 30	3,2	360, HV 10	2,5	500, HV 10	78,5	126,0
11 x 31 ¹⁾	-	-	3,1	500, HV 10	95,0	152,0
13 x 36 ¹⁾	5,3	360, HV 10	-	-	133,0	212,0
16 x 45 ¹⁾	8,2	360, HV 10	-	-	201,0	322,0
18 x 50	10,4	360, HV 10	8,3	450, HV 10	255,0	408,0
22 x 66 ¹⁾	15,0	360, HV 10	-	-	380,0	608,0
31,5 x 90 ¹⁾²⁾	31,8	360, HV 10	-	-	780,0	1247,0

Operating mode	ISO 4301	Hand Operated Hoist	Power Driven Hoist				
			1Cm	1Bm	1Am	2m	3m
Drive mechanism group							
Type of chain		T	DAT	DAT	DAT	DAT	DAT
Nominal stress at highest admissible chain force	[N/mm ²]	200	160	160	140	125	112
Nominal stress at minimum breaking force	[N/mm ²]	800	800	800	800	800	800
Minimum elongation at break	%	10	10	10	10	10	10
Under temperature limit	°C	-40	-20	-20	-20	-20	-20
Upper temperature limit	°C	200	200	200	200	200	200

Advices:

- 1) Limited tolerances. Meet also the requirements as per DSKN 726 300.
- 2) similar EN 818-7
- 3) **Type T** for manual hoists; **Type DAT** for power driven hoists.
- 4) The selection criteria of EN 818-7 part B for power driven hoists (influencing factors, like engine group, No. of teeth, speed, etc.) are to be considered. Surfaces optional bright polished or electro galvanized. Further finishes upon request. **Standard manufacturing lengths** 50m, other lengths upon request. **Hoist Chains are being proofed as per EN 818-7 and marked with T3 Thiele quality brand mark.**
- 5) Recommendation: In order to guarantee faultless operation, please send your sprocket.

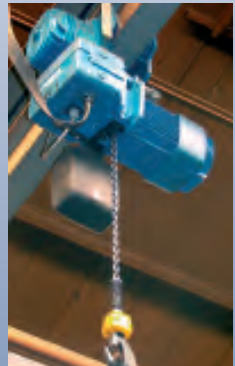



THIELE

App



THIELE



Hand Powered Cranes



TM-Series

Overload Protection

Advantages of the overload protection at TM-Series:

- ⊕ Prevents the hoist to be overloaded to a point when it becomes dangerous
- ⊕ Protects the hoist from damages
- ⊕ Protects the operator from injury
- ⊕ Provides additionally safety
- ⊕ Longer service life
- ⊕ Complies with DIN EN 13157, BGV-D8 und GPSG



Label

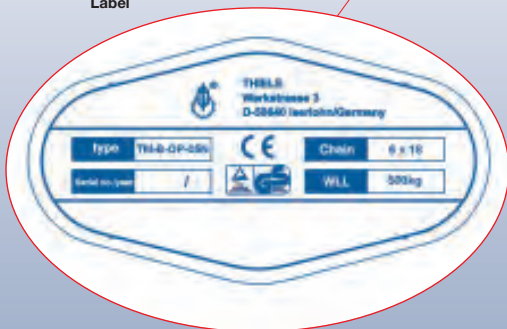

TM-Series

TM-Chain Block TWN 1000 TM-Lever Block TWN 1001

Advantages for your application:

- + with Overload Protection*
- + Lightweight robust steel construction
- + Super strength alloy loadchain as per EN818-7, galvanized and yellow chromated
- + Minimum headroom
- + Minimum effort to raise maximum load by easy handling
- + Hooks with strong cast steel safety latches
- + Lower hook easy turnable with roller bearing
- + Also approved for tensioning as per EN 12195 (only TM-Lever Block)
- + Fully enclosed gear train (TM-Chain Block only)
- + Protected automatic Weston brake with unique Twin Pawls
- + galvanised handchain as standard (TM-Chain Block only)
- + Durable baked enamel paint protection
- + Spare parts almost all available
- + TÜV / GS / CE approved
- + Supply with individual test certificate and manual in 7 languages
- + Approved for mining acc. to ATEX/68+69 (PN-EN 13463-1:2003)

*Except TM-LB 250 kg



TM-Chain Block
Capacities 500 kg to 5 tonnes



TM-Lever Block
Capacities 250 kg to 6 tonnes



TM-Series

TM-Chain Block TWN 1000 Capacities 500 kg to 5 tonnes

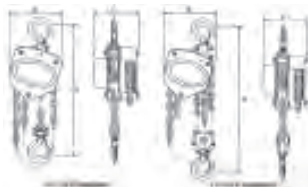

Working Load Limit	500 kg	1,0 to	2,0 to	3,0 to	5,0 to
Article No.	F06351	F06361	F06371	F06381	F06391
Article No. Special lift ¹	F06355	F06366	F06375	F06385	F06396
Standard lift	3 m	3 m	3 m	3 m	3 m
Falls of chain	1	1	1	2	2
Effort to lift W.L.L.	23 kg	30 kg	35 kg	27 kg	41 kg
Net weight	10 kg	12 kg	22 kg	32 kg	46 kg
Loadchain diameter	6 mm	6 mm	8 mm	8 mm	10 mm
Headroom (A)	270 mm	317 mm	414 mm	465 mm	636 mm
Width (B)	127 mm	158 mm	187 mm	210 mm	288 mm
Depth (C)	131 mm	140 mm	161 mm	161 mm	190 mm
Hook opening (upper)	36 mm	42 mm	46 mm	54 mm	64 mm
Hook opening (lower)	36 mm	42 mm	46 mm	54 mm	64 mm

TM-Lever Block TWN 1001 Capacities 250 kg to 6 tonnes

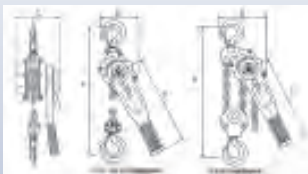

Working Load Limit / Lashing Capacity	250 kg ²	0,75 to	1,5 to	3,0 to	6,0 to
Article No.	F06190	F06241	F06251	F06261	F06271
Article No. Special lift ¹	F06194	F06545	F06255	F06265	F06275
Standard lift	1,5 m	1,5 m	1,5 m	1,5 m	1,5 m
Falls of chain	1	1	1	1	2
Effort to lift W.L.L.	2,5 kg	14 kg	22 kg	32 kg	34 kg
Net weight	1,8 kg	7 kg	11 kg	21 kg	31 kg
Loadchain diameter	4 mm	6 mm	8 mm	10 mm	10 mm
Length of lever handle (D)	160 mm	280 mm	410 mm	410 mm	410 mm
Headroom (A)	230 mm	325 mm	380 mm	480 mm	620 mm
Width (B)	85 mm	136 mm	160 mm	180 mm	235 mm
Depth (C)	92 mm	148 mm	172 mm	200 mm	200 mm
Hook opening (upper)	25 mm	42 mm	46 mm	54 mm	62 mm
Hook opening (lower)	25 mm	42 mm	46 mm	54 mm	62 mm

¹Special lifts upon request

²without overload protection

TM-Series

Load chain mounting TM-Chain Block

Chain plan

guide roller
No. 2 (inside)

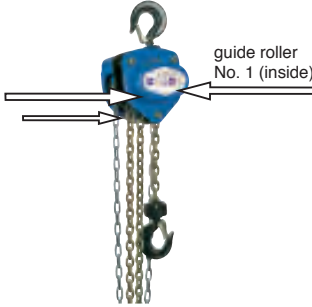

1. The load chain mounting is described in direction from hook to anchorage.
2. Pay attention not to twist the load chain.
3. The load chain will be carried by the sprocket in case of operation of the hand chain. It will be guided by the guide rollers.
4. Load chain ends should be fixed with bolts and split pins.
5. The load chain should be lubricated for the first use.

Position of chain end

1. vertical load chain end; welding-zone of all vertical chain links face outwards



Position of chain and guide roller No. 1

guide roller No. 1
Load chain below guide roller No. 1!



Position of chain and guide roller No. 2

guide roller No. 2
Load chain below guide roller No. 2!

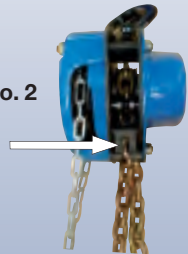

Load chain below of anchorage; will be fixed at anchorage later

Control

Right side view:
Hook / Bottom block in front



Left side view:
Anchorage in front





TM-Series

Load chain mounting TM-Lever Block

Chain plan

TM-LB 025
 TM-LB-OP 075 N
 TM-LB-OP 150 N
 TM-LB-OP 300 N



Chain plan

TM-LB-OP 600 N



Insertion of the chain

Welding zone of all vertical chain links face outwards

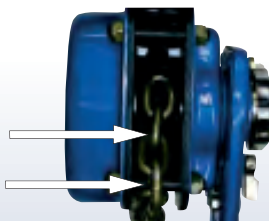

1. Switch direction-lever to „N“-position for load chain mounting.
2. Insert the load chain end to the sprocket, so that the welding zones of the vertical chain links face outwards.
3. Further move the load chain by turning the hand wheel.
4. TM-LB 025-300 N:
Fix load chain end to hook.

TM-LB 600 N:
Move load chain through bottom block and fix chain end to the top hook. Pay attention not to twist the chain. If necessary, shorten the chain by one link.
5. Fix loose load chain end by bolt and split pin to the chain ring (TM-LB 025: only spring ring).
6. The load chain should be lubricated for the first use.

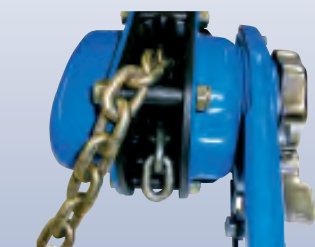

Control



TM-LB 025



TM-LB-OP 075 N
 TM-LB-OP 150 N
 TM-LB-OP 300 N

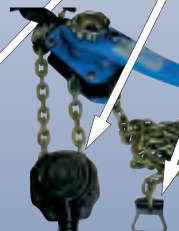

TM-LB-OP 600 N

TM-Series

TM Display

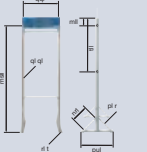
	Artikel-No.	Dimensions [B x H x T] [mm]	Weight app. [kgs]			
	F918186	550 x 1700 x 490	21 kg			

TM-Girder Clamp

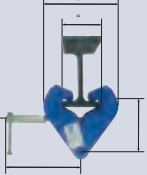
TWN 0899	Trade Size	Article-No.	Working Load Limit [t max]	Clearance Dimensions [mm]				Adjustable beam width [mm]
				A	B	E	F	
	1 t	Z08133	1,00	278	182	217	90	75-230
	2 t	Z08134	2,00	278	182	217	90	75-230
	3 t	Z08135	3,00	356	220	277	145	80-320
	5 t	Z08136	5,00	356	220	277	145	90-320







Spare Parts TM-Series for Chain Blocks

	Article-No.	suitable for TM-Chain Block	Working Load Limit [kg max]	
	Ratchet disc Part-No. 17 (before No. 27)			
	Z06928	B 05	500	
	Z06929	B 10	1000	
	Z06930	B 20	2000	
	Z06931	B 30	3000	
	Z06932	B 50	5000	

	Article-No.	suitable for TM-Chain Block	Working Load Limit [kg max]	
	Friction plate Part-No. 16 (before No. 28)			
	Z06934	B 05	500	
	Z06935	B 10	1000	
	Z06936	B 20	2000	
	Z06937	B 30	3000	
	Z06938	B 50	5000	

	Article-No.	suitable for TM-Chain Block	Working Load Limit [kg max]	
	Top hook assy Part-No. 6N (before No. 23)			
	Z09939	B 05	500	
	Z09940	B 10	1000	
	Z09941	B 20	2000	
	Z09942	B 30	3000	
	Z09943	B 50	5000	

	Article-No.	suitable for TM-Chain Block	Working Load Limit [kg max]	
	Safety clip Part-No. 7N (before No. 8N)			
	Z09944	B 05	500	
	Z09945	B 10	1000	
	Z09946	B 20	2000	
	Z09947	B 30	3000	
	Z09948	B 50	5000	

	Article-No.	suitable for TM-Chain Block	Working Load Limit [kg max]	
	Bottom hook assy Part-No. 8N (before No. 7N)			
	Z09949	B 05	500	
	Z09950	B 10	1000	
	Z09951	B 20	2000	
	Z09952	B 30	3000	
	Z09953	B 50	5000	



Spare Parts TM-Series for Lever Blocks

New

	Article-No.	suitable for TM-Lever Block	Working Load Limit [kg max]		
	Ratchet Disc Assy. part 21N for TM-LB-OP 150N				
	Z09455	LB 75N			
	Z09454	LB 150N			
	Z09456	LB 300/600N			

	Article-No.	suitable for TM-Lever Block	Working Load Limit [kg max]		
	Top hook assy Part-No. 8N (before No. 31N)				
	Z09968	LB 75	500		
	Z09969	LB 150	1500		
	Z09970	LB 300	3000		
Z09971	LB 600	6000			

	Article-No.	suitable for TM-Lever Block	Working Load Limit [kg max]		
	Bottom hook assy Part-No. 10N (before No. 33N)				
	Z09972	LB 75	500		
	Z09973	LB 150	1500		
	Z09974	LB 300	3000		
Z09975	LB 600	6000			



	Article-No.	suitable for TM-Lever Block	Working Load Limit [kg max]		
	Safety clip Part-No. 9N (before No. 61N)				
	Z09976	LB 75	750		
	Z09977	LB 150	1500		
	Z09978	LB 300	3000		
Z09979	LB 600	6000			



THIELE

App



THIELE



Rust & Acid Resistant Round Steel Chains





Rust & Acid Resistant Chains

Trade Size	Art.-No. Material 1.4401	Plant Standard TWN	W.L.L. [kg]	Test Force [kN]	Breaking Force [kN] min.	Standard	Nominal Size		Pitch t [mm]	Pitch Abw. / Tol.± [mm]	Width		Weight app. [kg/m]
							d [mm]	Abw. / Tol.± [mm]			b ₁ min. [mm]	b ₂ max. [mm]	
2 x 12	Z02607	TWN 0084	–	–	–	DIN 5685 ¹⁾	2	± 0,10	12	+0,6 / -0,6	3,6	–	0,07
2 x 22	Z02587	TWN 0084	–	–	–	DIN 5685 ¹⁾	2	± 0,10	22	+1,1 / -1,1	3,6	–	0,06
3 x 16	Z02658	TWN 0084	–	–	–	DIN 5685 ¹⁾	3	± 0,15	16	+0,8 / -0,8	5,4	–	0,16
3 x 26	Z02485	TWN 0084	–	–	–	DIN 5685 ¹⁾	3	± 0,15	26	+1,3 / -1,3	5,4	–	0,14
4 x 16	Z02604	TWN 0083	200	5	8	DIN 766	4	± 0,20	16	+0,3 / -0,2	4,8	13,6	0,31
4 x 19	Z02634	TWN 0084	–	–	–	DIN 5685 ¹⁾	4	± 0,20	19	+1,0 / -1,0	7,2	–	0,30
4 x 32	Z02824	TWN 0082	100	2,5	6	DIN 763 ³⁾	4	± 0,20	32	+1,0 / -1,0	7,2	16,8	0,26
5 x 18,5	Z02484	TWN 0083	320	8	13	DIN 766	5	± 0,20	18,5	+0,4 / -0,2	6,0	17,0	0,51
5 x 21	Z02743	TWN 0084	–	–	–	DIN 5685 ¹⁾	5	± 0,25	21	+1,1 / -1,1	9,0	–	0,48
5 x 35	Z02515	TWN 0082	160	4	10	DIN 763 ³⁾	5	± 0,25	35	+1,1 / -1,1	9,0	21,0	0,41
6 x 18,5	Z02633	TWN 0083	400	10	16	DIN 766	6	± 0,20	18,5	+0,4 / -0,2	7,2	20,4	0,79
6 x 42	Z02593	TWN 0082	200	5	12,5	DIN 763 ³⁾	6	± 0,20	42	+1,3 / -1,3	10,8	25,2	0,59
7 x 22	Z02710	TWN 0083	630	16	25	DIN 766	7	± 0,30	22	+0,4 / -0,2	8,4	23,8	1,06
8 x 24	Z02483	TWN 0083	800	20	32	DIN 766	8	± 0,30	24	+0,4 / -0,2	9,6	27,2	1,41
8 x 52	Z02530	TWN 0082	400	10	25	DIN 763 ³⁾	8	± 0,30	52	+1,6 / -1,6	14,4	33,6	1,08
10 x 28	Z02548	TWN 0083	1250	32	50	DIN 766	10	± 0,40	28	+0,5 / -0,3	12,0	36,0	2,28
13 x 36	Z02662	TWN 0083	2000	50	80	DIN 766	13	± 0,50	36	+0,6 / -0,3	15,6	47,0	3,87
13 x 82	Z02631	TWN 0082	1000	25	63	DIN 763 ³⁾	13	± 0,50	82	+2,5 / -2,5	23,4	54,6	2,95
16 x 45	Z02711	TWN 0083	3200	40	128	DIN 766	16	± 0,60	45	+0,8 / -0,4	19,2	58,0	2,87

Trade Size	Art.-No. Material 1.4571	Plant Standard TWN	W.L.L. [kg]	Test Force [kN]	Breaking Force [kN] min.	Standard	Nominal Size		Pitch t [mm]	Pitch Abw. / Tol.± [mm]	Width		Weight ca. / app. [kg/m]
							d [mm]	Abw. / Tol.± [mm]			b ₁ min. [mm]	b ₂ max. [mm]	
5 x 18,5	F00050	TWN 0083	320	8	13	DIN 766	5	± 0,20	18,5	+0,4 / -0,2	6,0	17,0	0,51
6 x 18,5	F00075	TWN 0083	400	10	16	DIN 766	6	± 0,20	18,5	+0,4 / -0,2	7,2	20,4	0,79
7 x 22	F000791	TWN 0083	630	16	25	DIN 766	7	± 0,30	22	+0,4 / -0,2	8,4	23,8	1,06
8 x 24	F00163	TWN 0083	800	20	32	DIN 766	8	± 0,30	24	+0,4 / -0,2	9,6	27,2	1,41
10 x 28	F00285	TWN 0083	1250	32	50	DIN 766	10	± 0,40	28	+0,5 / -0,3	12,0	36,0	2,28
10 x 65	F01138	TWN 0082	630	16	25	DIN 763 ³⁾	10	± 0,50	65	+2,0 / -2,0	18,0	42,0	1,68
13 x 36	F00385	TWN 0083	2000	50	80	DIN 766	13	± 0,50	36	+0,6 / -0,3	15,6	47,0	3,87
13 x 82	F01154	TWN 0082	1000	25	40	DIN 763 ³⁾	13	± 0,50	82	+2,5 / -2,5	23,4	54,6	2,87
16 x 45	F00485	TWN 0083	3200	40	128	DIN 766	16	± 0,60	45	+0,8 / -0,4	19,2	58,0	5,82

Trade Size	Art.-No. Material DUPLEX	Plant Standard TWN	W.L.L. [kg]	Test Force [kN]	Breaking Force [kN] min.	Standard	Nominal Size		Pitch t [mm]	Pitch Abw. / Tol.± [mm]	Width		Weight ca. / app. [kg/m]
							d [mm]	Abw. / Tol.± [mm]			b ₁ min. [mm]	b ₂ max. [mm]	
5 x 18,5	F00077	TWN 0083	560	14	22	DIN 766	5	± 0,20	18,5	+0,4 / -0,2	6,0	17,0	0,51
6 x 18,5	F00079	TWN 0083	800	20	32	DIN 766	6	± 0,20	18,5	+0,4 / -0,2	7,2	20,4	0,79
7 x 22	F00080	TWN 0083	1100	28	44	DIN 766	7	± 0,30	22	+0,4 / -0,2	8,4	23,8	1,06
8 x 24	F00165	TWN 0083	1400	35	55	DIN 766	8	± 0,30	24	+0,4 / -0,2	9,6	27,2	1,41
10 x 28	F00284	TWN 0083	2200	54	87	DIN 766	10	± 0,40	28	+0,5 / -0,3	12,0	36,0	2,28
10 x 65	F01144	TWN 0082	1200	30	48	DIN 763 ³⁾	10	± 0,50	65	+2,0 / -2,0	18,0	42,0	1,68
13 x 36	F00388	TWN 0083	3800	95	150	DIN 766	13	± 0,50	36	+0,6 / -0,3	15,6	47,0	3,87
13 x 82	F01154	TWN 0082	2000	50	80	DIN 763 ³⁾	13	± 0,50	82	+2,5 / -2,5	23,4	54,6	2,87
16 x 45	F004651	TWN 0083	5800	145	230	DIN 766	16	± 0,60	45	+0,8 / -0,4	19,2	58,0	5,82



Rust & Acid Resistant Chains

Rust & Acid Resistant Chains are mostly used at environmental processes with corrosive or aggressive influences, which one will find e.g. in the chemical industry, food industry, medical and pharmaceutical industry and ship building and/or ship ride. Due to their high value finish they also will find applications in architecture.

The materials 1.4401 (V4A), 1.4571 (V4A) and 1.4462 (DUPLEX) distinguish themselves through their corrosion resistance and mechanical qualities. The material 1.4571 differs to material 1.4401, due to the addition of Titan through a higher resistance against intergranular corrosion (EN10088-3, Tab. 10). The corrosion resistance is classified by the PRE number (Pitting Resistance Equivalent) as per standard VG81249.

The tables show that the material DUPLEX is especially marking off for a high resistance in sea water. In particular, the higher resistance in environments with high chlorinate- ions concentrations and higher temperatures are marking off, which one can find e.g. in the Southern Sea or Mediterranean areas. The higher strength up to 30%, at the same time has the advantage of lower weight, when selecting chains. Consequently, this material has an outstanding capability for all purposes especially as anchor chains (better distribution in the chain box) or for conveying systems (better gliding).

material	PRE No.
1.4401	23,10 – 26,75
1.4571	23,10 – 28,50
DUPLEX	30,85 – 38,07

as per VG 81249



PRE No.	Highest temperature for resistance in salt water
35	60° C
30	40° C
24	25° C
20	15° C
15	0° C



THIELE

App



THIELE



Fishing Chains





Fishing Chains TWN 0081

Field of application

Twist resistant round steel chains of this data sheet are used for all methods of commercial fishing. The geometrical dimensions match the corresponding type of trawl nets.

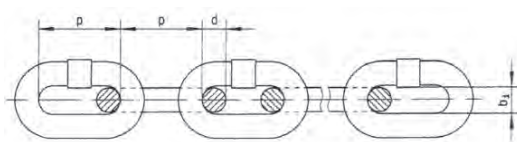

trade size [mm]	Type	Article-No.	diameter d		pitch p		inside width b ₁		breaking force min. [kn]	weight [kg/m]
			[mm]	perm. tol [mm]	[mm]	perm. tol [mm]	min. [mm]	max. [mm]		
Chains for Fishing Industry										
10 x 40	ML	F02881	10	± 0,4	40	± 1,2	13,5	15	126	2
13 x 55	ML	F02877	13	± 0,5	55	± 1,7	17,5	20	214	3,3
13 x 81	LL	F02873	13	± 0,5	81	± 2,4	17,5	20	214	2,9
16 x 64	ML	F02875	16	± 0,6	64	± 1,9	21,5	24	322	5,1
16 x 100	LL	F02876	16	± 0,6	100	± 3,0	21,5	24	322	4,4
19 x 76	ML	F02872	19	± 1,0	76	± 2,3	25,5	28,5	454	7,1
19 x 100	LL	F02874	19	± 1,0	100	± 3,0	25,5	28,5	454	6,5
22 x 88	ML	F02878	22	± 1,1	88	± 2,6	29,5	33	610	9,6
22 x 110	LL	F02871	22	± 1,1	110	± 3,3	29,5	33	610	8,8
26 x 140	LL	F02891	26	± 1,3	140	± 4,2	35	39	850	12
28 x 150	LL	F02879	28	± 1,4	150	± 4,5	38	42	986	14

Type ML = mid link
Type LL = long link

Specifications

- Material according to EN818-2
- Resistance 1100-1255 N/mm²
- Elongation at break min. 15 %
- Marking „KWS-8 Germany“ and identification code
- Finish: black coloured



THIELE

App



THIELE



Conveyor Chains for Poultry Industry





Conveyor Chains for Poultry Industry



Application: Chicken-Slaughterhouses.

Technical properties:

Calibrated Round Steel Chain



Dimension:	8 x 25,4 mm
Outside width:	max. 26,1 mm
Hardening depth:	min. 0,6 – 1,0 mm, at min. 550 HV
Measuring length:	11 x p = 279,4 mm $\pm 0,4$
Surface hardness:	min. 720 – 800 HV 10
Breaking force:	min. 40 kN
Finish:	electro galvanized
Marking:	THIELE quality brand mark T3
Weight per meter:	app. 1,32 kgs
Art-No.:	F06460

Chain connecting link



Dimension:	8 x 25,4 mm
Outside width:	max. 26,1 mm
Hardening depth:	min. 0,6 – 1,0 mm
Surface hardness:	min. 720 – 800 HV 10
Breaking force:	min. 25 kN
Finish:	electro galvanized
Marking:	THIELE quality brand mark T3
Weight per piece:	app. 0,04 kgs
Art-No.:	F42077



THIELE

App



THIELE



Conveyor Chains and Lifting Products for Forestry and Farming





Conveyor Chains and Lifting Products for Forestry and Farming

Round Steel Chains for agricultural trailers and dung spreaders.

Special round steel chains, according to TWN 5100, are mainly used on agricultural trailers, dung spreaders and other agricultural equipments.

TWN 5100	Trade Size	Article-No.	Operating Force [kn] max.	Proof Force [kn] min.	Breaking Force [kn] min.	Weight app. [kgs]
	Special Round Steel Chain in Special Grade, bright polished					
	8 x 22,8	F05011	18	45	63	1,40
	8 x 24	F05031	18	45	63	1,35
	8 x 28	F05062	18	45	63	1,30
	8 x 31	F05051	18	45	63	1,30
	9 x 27'	F05072	22,4	56	80	1,80
	9 x 31'	F05081	22,4	56	80	1,60
	9,5 x 27'	F05121	25	63	90	1,80
	10 x 26,5'	F05151	28	71	100	2,30
	10 x 28	F05155	28	71	100	2,30
	10 x 30,5	F05171	28	71	100	2,20
	10 x 31	F05181	28	71	100	2,20
	10 x 35	F05195	28	71	100	2,05
	10 x 38'	F05201	28	71	100	2,02
	11 x 31	F05221	33,5	85	120	2,70
	11 x 35	F05230	33,5	85	120	2,60
	12 x 36	F05251	40	100	140	3,20
	12 x 42	F05261	40	100	140	2,90
	13 x 36	F05285	47,5	118	170	3,80
	13 x 45'	F05291	47,5	118	170	3,45
13,2 x 62'	F05351	47,5	118	170	3,10	
14 x 42	F05331	53	132	190	4,30	
16 x 56'	F05355	71	180	250	5,40	
*Finish: bright polished						

The length tolerance of chain strands for each strand is ($^{+0,3}_0$) %.

The length tolerance of matched pair chain strand is 0,1%.

For the measurement of the length of matched pair chain strands, each chain strand must be free of torsion and strained or hanged with 1 % of the corresponding breaking force.

	Trade Size	Article-No.	Breaking Force [kn] min.	Weight app. [kgs]	
	Special Chain for Dung Spreaders and Trailers as per DIN 22252				
	14x50 GK1	F13107	194	3,90	
	14x50 GK2	F13101	264	4,00	
Finish: bright polished					



Conveyor Chains and Lifting Products for Forestry and Farming

TWN 5200 * Typ VGG  ** Typ VG 	Trade Size	Article-No.	Breaking Force [kn]	Weight app. [kgs]	
	Special Connecting Link, bright/electro galvanized				
	8x24/8x22,8	F05500 **	70	0,066	
	8x31/9x31	F05510 **	85	0,079	
	8 x 28		85	0,079	
	9,5x27/10x26	F05531 **	90	0,095	
	10 x 28	F05541 **	100	0,100	
	10 x 30,5	F05550 **	100	0,114	
	10x31/11x31	F05550 **	100	0,114	
	8 x 31	F05520 *	85	0,079	
	10 x 31	F05551 *	100	0,114	
	10 x 35	F05555 **	100	0,100	
	10 x 38 ¹	F05560 **	100		
	11 x 35	F05556 *	100	0,130	
	11 x 35	F05564 **	100	0,100	
	12 x 36	F05574 **	140		
	12 x 42	F05573 *	140		
	13 x 36	F05570 **	170		
	13 x 45 ¹	F05575 **	170	0,255	
	14 x 42	F05568 **	190		
Min. Order Quantity 30 pieces					
Finish: *electro galvanized, ** bright polished, ¹ upon request					

	Trade Size	Article-No.	Breaking Force [kN]	Weight app. [kgs]	
	Chain Connector as per DIN 22253				
	14x50	F25006	212	0,675	
with screw M16 x 65 as per DIN 931 ST 8.8 and nut as per DIN 985-1610 suitable for chain as per DIN 22252					





Conveyor Chains and Lifting Products for Forestry and Farming

TWN 5201	Trade Size	Article-No.	Type	Weight approx. [kgs]	
	Special Flange				
	8x24/8x22,8	Z03598	MF8x22,8/24	0,016	
	8x31	Z03599	MF8x31	0,045	
	9,5x27	Z03600	MF9,5x27	0,046	
	10x31	Z03602	MF10x31	0,062	
	10x38	Z03603	MF10x38	0,062	
	min. order quantity 50 pcs.				

TWN 5202	Trade Size	Article-No.	Type	Weight approx. [kgs]	
	Special Hammer Head Screw				
	8x24/8x22,8	Z03868	HK 8	0,015	
	9,5x27	Z03870	HK 9,5x27	0,022	
	10x31	Z03871	HK 1010	0,035	
min. order quantity 50 pcs.					

TWN 5204	Trade Size	Article-No.	Type	Weight approx. [kgs]	
	Special-Drive-Pocket-Wheel				
	9x31	Z03584	58 B04	2,90	

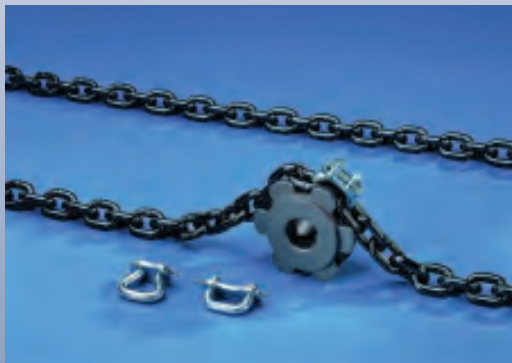



THIELE

App



THIELE



Inspection Service





Inspection Service

Regular inspection of work equipment

According to the BGR 500, Section 2.8, round steel chains, lifting equipment, and load suspension equipment are subject to mandatory inspections.

Par. 1 of the German Occupational Health and Safety Act and Par. 3 of the Operational Safety Act specify that the employer is responsible according to his risk assessment to take the necessary measures for the safe provision and use of the work equipment.

In Par. 4, Par.10 and Par.11 of the Operational Safety Act, these responsibilities are specified in more detail. The employers' liability insurance associations, on the other hand, provide recommendations as insurers for the safe operation of work equipment that can be used as standards in the event of an insurance claim.

We view our task is to be provide you the support in the planning and fulfillment of these requirements.

From the exact **analysis** of the current state and the **optimization** of the processes to the safe use of your equipment, we provide your company with support using our years of experience. We would be happy to completely take over parts of the areas you are responsible for and offer you **individualized maintenance and service contracts**.

Together with you, we will increase the level of safety in your company and ensure the economical and efficient use of your equipment over the long term.

Our customer services:

Load suspension and lifting equipment in lifting operations, BGR 500, Section 2.8

Round steel chains, lifting chains, lifting beams, lifting equipment, textile ropes and straps, steel cables, lashing chains and belts, load securing devices

- **Visual inspections** and functional checks should be performed regularly at least once per year
- It is recommend to conduct **non-destructive crack checks** on round steel chains used for lifting at an interval of no longer than three years
- **Maintenance, repair,** and manufacture of new chain slings on-site with a test certificate
- Value preservation analysis and documentation, also in digital form

Winches, lifting, and tensioning devices BGV D8

Mechanical winches of all type, metal grippers, clamps, ratchet hoists, cable hoists, magnets, ratchet lever hoists, etc.

- **Visual inspections and functional checks** up to a tensile force of **12t** and a pressure of **23t** on our portable test rigs
- Maintenance and servicing on-site, repairs upon request

Personal protection equipment, protection against falling, and rescues from heights, BGR 198,199

Harnesses, fastening equipment, hoisting cables, fall arresters, etc.

- **Visual inspections** and functional checks at least once per year

- **Expert examination** of PPE after a fall

Documentation, organization, prevention

- Management of records, inspection log books, repair reports, test certificates, etc. in written or even in digital form
- Reminder service for your inspection intervals
- Meetings before and after inspections to improve the efficiency and effectiveness of maintenance and service measures
- **We provide all services during all three shifts, on weekends, and on holidays.**
- **Drive-in service** in our factory in Iserlohn for trucking companies, construction companies, tradesmen, vehicles in use, or in especially urgent cases. When one half hour notice in advance is given or another appointment is agreed to, we will immediately inspect the work equipment delivered.

Consulting and Analysis

Give us a call. We would be pleased to make an appointment with you and advise you in aspects of our range of products and services, even at your company site.

Contact

Your contact is:
Mr. Reiner Homrighausen,
Tel.: +49 2371/947-226
Fax: +49 2371/947-241
E-Mail: r.homrighausen@thiele.de



THIELE

App



THIELE



Special Chains





Round Steel Link Chains (acc. to DIN 763,766)

DIN 763

This standard is valid for tested non-calibrated long link round steel chains.

Chains as per this standard are not allowed to be used as load suspension devices, lifting devices or suspension elements in the sense of DIN 15003.

Finish: self coloured, bright polished, electro galvanized, hot dipped galvanized

Minimum order quantity: 30 m bundle only

Dimension [mm]	W.L.L. [t]	weight [kg/m]	Artikel-No. Finish			
			self col.	bright pol.	galv.	hot dipped galv.
4 x 32	0,10	0,27	Z00013	F01013	F01011	F01019
5 x 35	0,16	0,43	F01032	F01035	F01038	F01041
6 x 42	0,20	0,63	Z00015	F01057	F01069	F01063
7 x 49	0,30	0,86	F01082	F01085	F01086	F01091
8 x 52	0,40	1,10	Z00019	F01107	F01110	F01113
10 x 65	0,63	1,75	F01126	F01129	F01134	F01135
13 x 82	1,00	2,95	Z02516	F01152	F01159	F01158
16 x 100	1,60	4,45	F01172	F01175	-	F01187

DIN 766-3

This standard is valid for tested calibrated short link round steel chains in Grade 30.

Chains as per this standard are being used in the area of the whole industry.

The round steel chains are heat treated and comply with the safety-related requirements according to DIN 685 part 2.

Minimum order quantity: 50 m bundle only

Dimension [mm]	W.L.L. [t]	weight [kg/m]	Artikel-No. Finish			
			self col.	bright pol.	galv.	hot dipped galv.
4 x 16	0,20	0,32	F00011	F00013	F00016	F00015
5 x 18,5	0,32	0,50	Z00114	F00042	F00038	F00039
6 x 18,5	0,40	0,80	F00055	F00059	F00061	F00062
7 x 22	0,63	1,10	F00089	F00092	F00095	F00093
8 x 24	0,80	1,40	F00131	F00134	F00137	F00136
9 x 27	1,00	1,80	F00184	F00178	F00181	F00199
10 x 28	1,25	2,30	F00273	F00258	F00261	F00260
11 x 31	1,60	2,70	F00306	F00300	F00303	F00321
13 x 36	2,00	3,90	F00395	F00380	F00383	F00376
16 x 45	3,20	5,80	F00460	F00463	F00466	F00464



Special Steel Link Chains

THIELE also manufactures round steel chains made of special materials and heat-resistant materials for the broadest range of applications.

Naturally we also manufacture chains and accessories in accordance with numerous German and international standards.

Further Product Range:

- » Suspension chains for mining and tunneling
- » 2-wheel safety chains
- » Heat resistant chains
- » Sugar cane chains
- » Non magnetic chains for marine boats

Please feel free to contact us if you would like to learn more and request an offer.

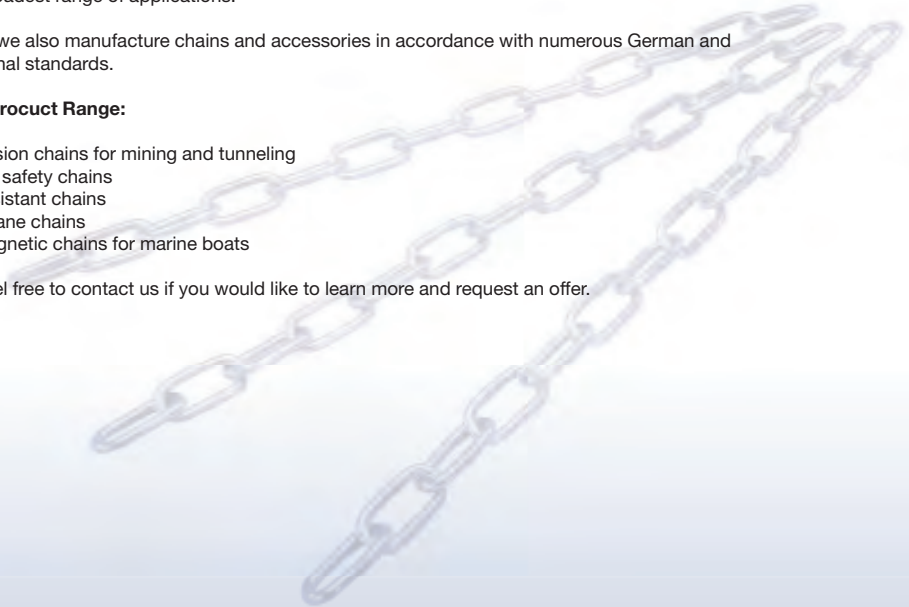



Index

Article	TWN No.	Grade 80 /Grade 100	Page
Assembly			24
Assembly Sets	TWN0945	GK10-XL	45+96
Balancer	TWN0882	GK8	93
Blocking Device	TWN0885	GK8	94
Bolt Shackles Type C	TWN1871	GK10-XL	43
Bolt Shackles Type C	TWN0871	GK8	88
Cargo Securing with THIELE			135-141
Cargo Shackles	TWN0898	GK8	89
Chain and Wire Rope Cutter	TWN0941		102
Chain Block (TM-Series)	TWN1000		169+170
Chain Coupling Bolt Shackles	TWN0862	GK8	87
Chain Gauge	TWN1946	GK10-XL	50
Chain Gauge Set	TWN0946		96
Chain inspection gauge		GK10-XL	24
Chain Sling marking		GK8	66
Chain Slings with THI-LOK-coupling (1-Leg)		GK8	106
Chain Slings with THI-LOK-coupling (2-Leg)		GK8	107
Chain Slings with THI-LOK-coupling (4-Leg)		GK8	108
Chain Slings with XL-LOK-coupling (1-Leg)		GK10-XL	51
Chain Slings with XL-LOK-coupling (2-Leg)		GK10-XL	52
Chain Slings with XL-LOL-coupling (4-Leg)		GK10-XL	53
Chain Slings, Fixed Size (1-Leg)	TWN1631, TWN1632	GK10-XL	54
Chain Slings, Fixed Size (2-Leg)	TWN1681, TWN1682	GK10-XL	54
Chain Slings, Fixed Size (4-Leg)	TWN1781, TWN1782	GK10-XL	55
Chain Tensioner	TWN1450, TWN1451, TWN1452	GK8	90+149
Chain Tensioner	TWN1454	GK10-XL	42+155
Chain Tensioner	TWN1455	GK10-XL	43+155
Chain Testing Service			189
Connectors THI-LOK	TWN0829	GK8	77+151
Connectors XL-LOK	TWN1829	GK10-XL	34+159
Contact Persons			8-9
Display			173
Endless Chains, K11, K12, K13		GK10-XL	57
Eye Hooks	TWN0855, TWN0855/1	GK8	82
Eye Slip Hooks SOLIDO	TWN0858/1	GK8	83
Foundry Hooks with Pin Coupling	TWN0859	GK8	83
Foundry or Container Eye Hooks	TWN0856	GK8	82
Girder Clamps	TWN0899		173
Hand Powered Cranes (TM-Series)			167-175
Hitches			131-132
Hoist Chains EN818-7			163-165
Hooks		GK10-XL	35-38
Hooks		GK8	80-85
Identification Tags for Chain Slings	TWN1940	GK10-XL	50
Intermediate Master Links, Type B	TWN0795	GK8	71
Intermediate Master Links, Type B	TWN1795	GK10-XL	31
Isolation Assemblies	TWN0893	GK8	94
Key design		GK8	103-105
Key Hooks	TWN0892	GK8	94
Lashing chains with ratchet DIN EN12195-3	TWN1401	GK8	97+147
Lashing Chains	TWN1410	GK10-XL	44
Lashing Chains		GK8	97 / 143 / 147
Lashing Chains with ratchet	TWN1411	GK10-XL	45+153
Lashing Chains with T-handle DIN EN12195-3	TWN1400	GK8	97+147
Lashing Chains with T-handle DIN EN12195-3	TWN1410	GK10-XL	153
Lashing Products for Forestry and Farming			185-188
Lashing Products, Overview		GK8/GK10-XL	134

Index

Article	TWN-No.	Grade 80 /Grade 100	Page
Lever Block (TM-Series)	TWN1001		170
Liability			24
Lifting Hooks for Engines	TWN0889	.GK8	85
Lifting Point ZK-Modul	TWN1470	.GK8	126+127
Lifting Points, Product Overview		.GK8/GK10-XL	112
Lifting Points, screwed type		.GK8/GK10-XL	116-121
Lifting Points, screwed type	TWN0122/1	.GK8	116
Lifting Points, screwed type	TWN0123	.GK8	117
Lifting Points, screwed type	TWN0127	.GK8	117
Lifting Points, screwed type	TWN1120	.GK10-XL	118
Lifting Points, screwed type (rotating)	TWN0121/1	.GK8	116
Lifting Points, screwed type (X_TREME)	TWN1830	.GK10-XL	119
Lifting Points, screwed type (XS-POINT)	TWN1890	.GK10-XL	120+121
Lifting Points, weld-on type		.GK8/GK10-XL	124-128
Lifting Points, weld-on type	TWN0119	.GK8	124+151
Lifting Points, weld-on type (with spring)	TWN0124	.GK8	124+151
Lifting Products for Forestry and Farming			185-188
Lifting Products Offshore			109
Lifting Products, Product Overview		.GK10-XL	16-19
Lifting Products, Product Overview		.GK8	60-64
Manual Instructions		.GK10-XL	58
Manual Instructions		.GK8	110
Marking		.GK10-XL	23 + 50
Master Link Assemblies	TWN1809	.GK10-XL	31
Master Link Assemblies	TWN0796	.GK8	71
Master Link Assemblies	TWN0809	.GK8	75
Master Link Assemblies (Fixed Size)	TWN1810	.GK10-XL	32-33
Master Links	TWN1807,TWN1808	.GK10-XL	30
Master Links (Fixed Size)	TWN0810/1-2-4	.GK8	76-77
Master Links for Single Leg with Pin Coupling	TWN0820	.GK8	79
Material			24
Oblong Master Links	TWN0807, TWN0808	.GK8	74
Operating Manual Lifting Points			129-130
Oversize Master Links	TWN0815, TWN0816, TWN0817	.GK8	78-79
Pipe Transport Hooks	TWN0868	.GK8	84
Plate Hooks for Basket Chain	TWN0872, TWN0873	.GK8	84
Product Overview, Lashing Products		.GK8/GK10-XL	134
Product Overview, Lifting Points		.GK8/GK10-XL	112
Product Overview, Lifting Products		.GK10-XL	16-19
Product Overview, Lifting Products		.GK8	60-64
Reduction Assemblies	TWN0875	.GK8	92
Ringshackles	TWN1812	.GK10-XL	44
Ringshackles	TWN0812	.GK8	91
Round Steel Chains (Rust & Acid Resistant)			177-179
Round Steel Chains for Fishing Industry			181-182
Round Steel Chains for for Poultry Industry			183-184
Round Steel Chains for Forestry and Farming			185-188
Round Steel Link Chains		.GK10-XL	28-29/154
Round Steel Link Chains		.GK8	70+148
Round Steel Link Chains (according to DIN 763, 766)		.GK8	190
Self Locking Hooks with Clevis	TWN1837	.GK10-XL	35
Self Locking Hooks with Eye	TWN1836	.GK10-XL	35
Self Locking Hooks with Swivel	TWN1838	.GK10-XL	36
Self-Locking Clevis Hooks	TWN0799	.GK8	80
Self-Locking Eye Hooks	TWN0798	.GK8	80
Our seminar Program			10



Index

Article	TWN.No.	Grade 80 /Grade 100	Page
Shackles		GK8	87-89
S-Hooks	TWN0860	GK8	83
Shortening Claws RAPID	TWN1852	GK10-XL	39+158
Shortening Claws with Clevis	TWN1851	GK10-XL	39
Shortening Claws with Pin Coupling	TWN0851	GK8	86
Shortening Components		GK10-XL	38-41
Shortening Components		GK8	86-87
Shortening Devices for fixed size Master Links	TWN0896	GK8	87
Shortening Devise (Fixed Size)	TWN1896	GK10-XL	41
Shortening Hooks with Clevis	TWN1827/1	GK10-XL	38+157
Shortening or Grab Hooks	TWN0827, TWN0827/1	GK8	86+150
Skip Suspension Links with Pin Coupling	TWN0869	GK8	92+152
Sling Hooks with Clevis	TWN1840	GK10-XL	37+156
Sling Hooks with Eye	TWN1841/1	GK10-XL	38
Sling Hooks with Pin Coupling and Safety Latch	TWN1340/1	GK8	80
Sling Hooks with Pin Coupling and Safety Latch	TWN0835/1	GK8	81+150
Spare Parts and Accessories		GK10-XL	46-49
Spare Parts and Accessories		GK8	98-101
Spare Parts for Clevis Self Locking Hook	TWN1933/0	GK10-XL	48
Spare Parts for Clevis Type Hooks	TWN1904	GK10-XL	46
Spare Parts for C-Shackles	TWN1930	GK10-XL	47
Spare Parts for RAPID Shortening Claws	TWN1931/0	GK10-XL	48
Spare Parts for Self Locking Hooks	TWN1935	GK10-XL	49
Spare Parts for Sling Hooks	TWN1908/0	GK10-XL	46
Spare Parts for XL-LOKs	TWN1929/0	GK10-XL	47
Spare Parts TM-Series		GK8	174-175
Spare Parts-for Bolt Shackle and C-Shackle	TWN0930/0932	GK8	99
Spare Parts-for Chain Shackles	TWN0905/0906	GK8	98
Spare Parts-for Clevis Self Locking Hooks	TWN0967/0-1	GK8	100+101
Spare Parts-for Clevis Type Hooks	TWN0904	GK8	98
Spare Parts-for Eye Hooks	TWN0920-0922	GK8	98
Spare Parts-for lockable Grab Hook	TWN0950-0952	GK8	99
Spare Parts-for Skip Suspension Links	TWN0962	GK8	100
Spare Parts-for Sling Hooks	TWN1908/5,TWN0908/0	GK8	101
Spare Parts-for THI-LOK S	TWN0929/0	GK8	99
Special Chain Coupling Shackles	TWN0861	GK8	87
Special Chains		GK8	191-193
Special Coupling Shackles	TWN0897	GK8	88
Special Shackles	TWN0870	GK8	88
Special Sling Components	TWN1812	GK10-XL	44
Special Sling Components	TWN0812	GK8	91-95
Suspension Components		GK10-XL	30-33
Suspension Components		GK8	71-79
Swivel Adapter	TWN0895	GK8	95
Swivel Hooks	TWN0887	GK8	85
Swivel Hooks with Safety Latch	TWN0854	GK8	81
Swivels	TWN0845	GK8	91
Tally for Single and Multi Leg Sling Chain	TWN0940	GK8	95
Tensioner, TM Ratchet Tensioners		GK8	161
Tensioning Tags	TWN1402	GK10-XL	45+96
T-Handle Chains	TWN0894	GK8	95
TOP-Range		GK8	13
Welded Attachment Point	TWN1880	GK10-XL	128+160
Weld-On Hooks	TWN0850/1	GK8	125
Working Load Limit Table for Lifting Points		GK8/GK10-XL	114+115 / 122+123
Working Load Limit Tables		GK10-XL	25-27
Working Load Limit Tables		GK8	67-69
ZK-Modul, Lifting Points	TWN1470	GK8	126+127+146+152



Promotional Materials

Roll up-Displays



Roll up »Image«



Roll up Lifting Products Grade 80



Roll up »Lifting Points«



Roll up Hoist Chains and TM-Series



Roll up Lifting Products Grade 100 (XL)



THIELE



บริษัท ไทแทน เซอร์วิส จำกัด

1/19 หมู่ 1 ต.พิมพา อ.บางปะกง จ.ฉะเชิงเทรา 24130 ประเทศไทย

TAX ID 0245554000604 Hotline 063-273-1222

Tel. : 038-989-373 ถึง 76 Fax. 038-989-377

Line : @titanservice Email: info.titanservice@gmail.com

www.titanservice.co.th Facebook.com/Titanservicecompany

THIELE®