

X-STREAM™ FLOW METER

Check air flow - monitor usage and waste!!!

WHAT ARE THEY - REASONS TO USE

THE X-STREAM™ FLOW METER IS

- ▶ Reliable, durable thermal mass flow technology
- ▶ Milliamp and pulse outputs for logging and remote monitoring
- ▶ 100:1 turndown capability
- ▶ Available for steel pipe, ½" through 2"
- ▶ No calibration or setup required
- ▶ Complete flow meter in one package



The **X-STREAM™ FLOW METER** represents a radical departure from conventional flow meter designs, providing easy installation, low cost, and accurate placement of the probes in the air stream. The meter clamps around a pipe with its probes projecting into the pipe through drilled holes. The low cost of the meter makes it ideal for installation at points throughout an air distribution system to track valuable compressed air and assess system operation.

SPECIFICATIONS:

- Accuracy** : 5 percent of reading plus one percent of full scale at air temperatures between 40°F and 120°F
 - Fluids** : Compressed air and nitrogen
 - Operating pressure** : 30 to 170 psig for best accuracy 200 psig maximum on Schedule 40 steel.
 - Input power** : 250 mA at 18 to 24 Vdc
 - Output resistance** : 400 Ohms max.
 - Wetted materials** : Stainless steel, gold, thermal epoxy and Viton (seal)
 - Ring material** : Aluminum
 - Display** : Four-digit LED display
 - Response time** : One second to 63 percent of final value
- US Patent 6,802,217**



The **X-Stream™ Flow Meter** measures mass flow based on heat and on pipe diameter. Accurate flow rate tracks air consumption.

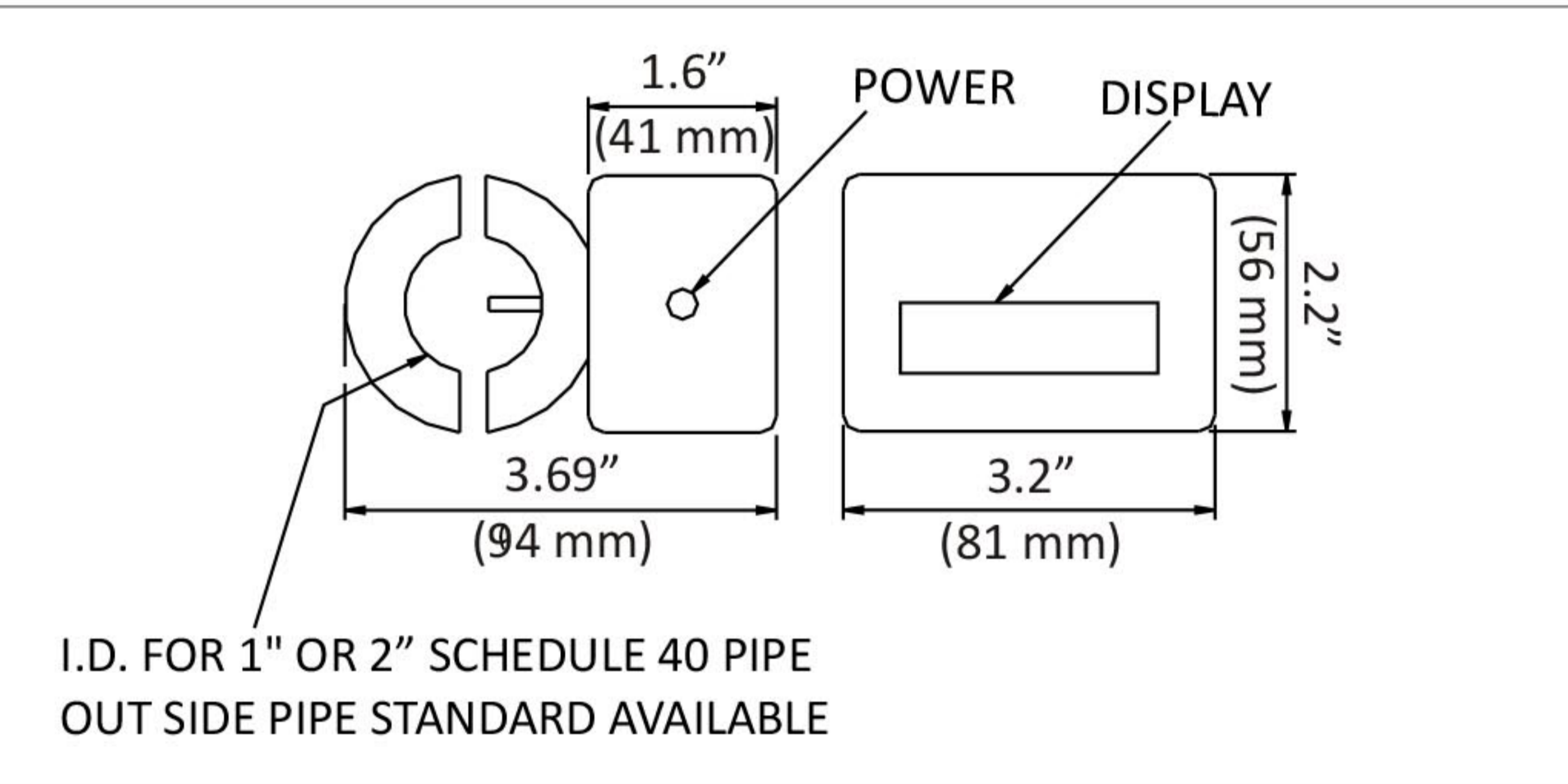

The **X-Stream™ Flow Meter** clamps onto a pipe, with two flow sensing probes projecting into the pipe through 3/16-in. drilled holes. It seals directly to the pipe; no cutting or welding is required for installation. Because each flow meter is made and calibrated for a specific size of pipe, the digital display indicates flow directly, with no setup or adjustment. The meter measures flow by maintaining one probe warmer than the other. It calculates the mass velocity from the amount of heat required, and then calculates the flow on the basis of pipe area. The flow rate, in SCFM, is shown on a large, four-digit display; a 4-20 mA output and a pulse output permit remote display, totalizing and data collection. Metric display is optional.

ULTRASONIC LEAK DETECTOR

PART NO.	DESCRIPTION
90092	1" (Schedule 40 iron pipe) 1 - 80 SCFM without Drill Guide Kit
90093	1.5" (Schedule 40 iron pipe) 2 - 200 SCFM without Drill Guide Kit
90095	2" (Schedule 40 iron pipe) 3 - 300 SCFM without Drill Guide Kit
DRG-9	Drill Guide Kit Only
90092-DRG-9	1" (Schedule 40 iron pipe) 1 - 80 SCFM with Drill Guide Kit
90093-DRG-9	1.5" (Schedule 40 iron pipe) 2 - 200 SCFM with Drill Guide Kit
90095-DRG-9	2" (Schedule 40 iron pipe) 3 - 300 SCFM with Drill Guide Kit

ABOVE FOR AMERICAN STANDARD STEEL PIPING - CAN ALSO SUPPLY TO DIN STANDARD OTHER PIPE SIZES & COPPER. QUOTE ON REQUEST

