



JTS[®] PROFESSIONAL CO., LTD.

No. 148, 9th Industry Road, Ta-Li Industrial Park,
Taichung City, Taiwan, R.O.C.

Tel: 886-4-24938803 Fax: 886-4-24914890

E-mail: jts@jts.com.tw

www.jts.com.tw



59508-099-02

JTS[®]
JTS PROFESSIONAL CO., LTD.

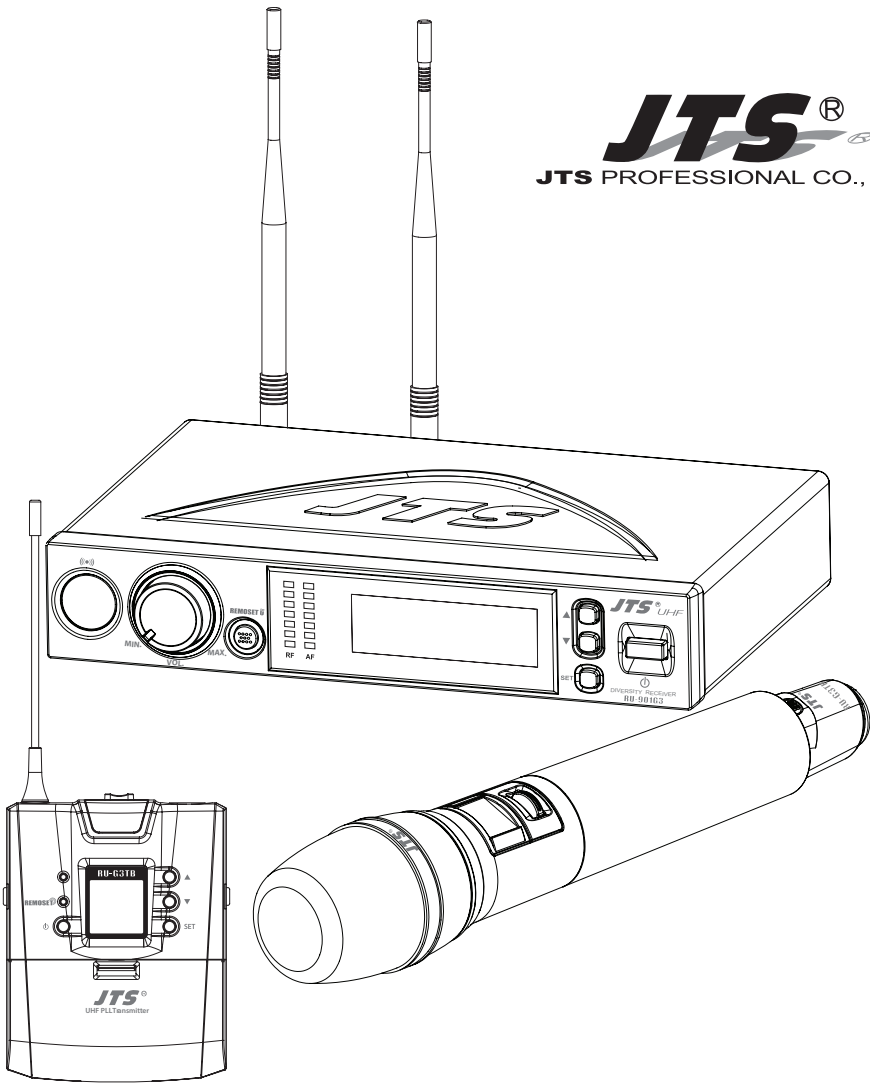

UHF PLL

RU-901G3 /RU-G3TH /RU-G3TB Instruction Manual



With JTS **REMOSET**  Ultrasonic Synchronizing Technology

One year product warranty

Product Model		Equipment serial number	
Customer name		Contact number	
Address			
Purchase date			
Selling store stamp	Be sure to put store stamp and fill in purchase date for the warranty to be effective!		

Warranty description

1. Be sure to put the warranty label indicating purchase date on the bottom of equipment to ensure your interest in maintenance and service.
2. Product warranty, starting on the purchase date indicated on “warranty label”, will last for one year; if the equipment does not have “warranty label”, the warranty period is 15 months from the manufacturing date. If a microphone is broken but not sent back with the equipment, the warranty period is 15 months from the manufacturing date of the microphone.
3. Within the warranty period, if the equipment is broken under normal use as instructed in manual, please contact the original selling store for repair.
4. When the product is returned for repair, to facilitate proper determination of cause of malfunction and of whether repair fee is needed, please ship back the equipment and microphone together.
5. Within the warranty period, our company provides repair service at no cost except for the following conditions that parts and repair may be charged:
 - a. Damages due to natural disaster or irresistible outside forces.
 - b. Damages due to drop, water, moisture, corrosion, foreign objects, missing components.
 - c. The warranty does not cover consumable parts. (such as microphone capsule, ball grille etc.)
 - d. Those without “warranty label” on equipment or with “warranty label” being damaged and failing to identify warranty period.
6. Please keep the warranty properly. No replacement will be made if the warranty is missing.

INDEX

1. Notes for system operations	1
2. Features	1
3. Specifications	2
3-1 UHF PLL single-channel True Diversity receiver// RU-901G3	2
3-2 UHF PLL hand-held transmitter // RU-G3TH	3
3-3 UHF PLL body-pack transmitter // RU-G3TB	4
3-4 Optional condenser microphone	4
4. Description of parts	7
4-1 UHF PLL single-channel True Diversity receiver // RU-901G3	7
4-2 UHF PLL hand-held transmitter // RU-G3TH	9
4-3 UHF PLL body-pack transmitter // RU-G3TB	11
4-4 Optional remote mute switch PT-RMS	12
4-5 Optional Condenser Microphone	12
4-6 Accessories	16
5. Connecting	17
5-1 How to connect the receiver// RU-901G3	17
5-2 Transmitter installation // RU-G3TH/G3TB	18
6. Instructions for use	19
6-1 How to use// RU-901G3	19
6-2 How to use// RU-G3TH/G3TB	23
6-3 Installation of Condenser Microphones	25
7. Notes for the product	27

1. Notes for system operations

- Before connecting the power, check that the power requirement shown on the unit is the same as the power output on the adaptor supplied.
- Do not leave the unit at where the humidity and temperature are high.
- Dry your hands before operating the system.
- Keep the unit away from fire and heat source.
- Turn the volume to minimum at both the mixer and amplifier before setting up the system.

2. Features

- 3rd generation True Diversity system
- Transmission power selectable between "High" and "Low"
- 6 groups are provided as default. Every group contains up to 23 default channels.
- There are in total 1,441 channels to choose from.
- 36MHz bandwidth.
- The patented **REMOSET**  ultrasonic pairing for synchronized setting of all parameters
- Channel scan
- Adjustable receiving sensitivity
- Automatic microphone power off
- Charging contact ready

3. Specifications

3-1 UHF PLL single-channel True Diversity receiver // RU-901G3

Frequency Oscillation Mode	Phase-locked loop (PLL)
Carrier Frequency Range	470~960 MHz
Remoset Frequency	Ultrasonic
Diversity	True diversity
Bandwidth	36MHz
Signal/Noise Ratio	>105dB(A)
Total Harmonic Distortion (Thd)	<0.6%@1KHz
Receiving Sensitivity	-95dBm · S/N>80dB
Image Rejection Ratio	>80 dB
Frequency Response	50Hz~18KHz±2dB
Antenna Type	1/2λ BNC detachable
Antenna Booster Power	DC12~15V/100mA
Function Display By	LCD
Contents Of Display	Group, channel, frequency, battery level, antenna A/B, muting , AF indication, RF indication, channel scanning, output level attenuation
Control Functions	Power, group, channel, frequency, muting , button lock, volume, output attenuation (XLR), channel scan (on/off)
Audio Frequency Output Level	ψ6.3 Phone Jack : -10dBV XLR Jack : -4dBV(Line) 、 -24dBV(MIC)
Audio Frequency Output Impedance	600Ω
Muting	Noise muting and tone code locking
Output Port	1 x balanced XLR jack 1 x unbalanced φ6.3 jack
Power Supply	12~15V DC / 500mA
Dimension (Mm)	212.3mm (W) x 38.3mm (H) x 144mm (L)

3-2 UHF PLL hand-held transmitter // RU-G3TH

Frequency Oscillation Mode	Phase-locked loop (PLL)
Carrier Wave Frequency Range	470~960 MHz
Remoset Frequency	Ultrasonic
RF Power Output	10mW/50mW(as per local regulations)
RF Stability	$\leq \pm 10\text{KHz}@F_c$
Modulation Frequency Shift	$\pm 48\text{KHz}$
Harmonic Radiation	$< -50\text{dBc}$
Display By	LCD+LED
Controls	Power, mute, group, channel, frequency, sensitivity adjustment, auto off, button lock, RF power
Battery	AA alkali battery or MiNH rechargeable battery x 2
Charging	Yes
Dimension	51mm (W) x 269mm (H) x 26mm (L)

3-3 UHF PLL body-pack transmitter // RU-G3TB

Frequency Oscillation Mode	Phase-locked loop (PLL)
Carrier Wave Frequency Range	470~960MHz
Remoset Frequency	Ultrasonic
RF Power Output	10mW/50mW(as per local regulations)
RF Stability	$<\pm 10\text{KHz}@F_c$
Modulation Frequency Shift	$\pm 48\text{KHz}$
Harmonic Radiation	$<-50\text{dBc}$
Functions	Mute, auto off, input level attenuation, sensitivity adjustment, low power indication, RF power
Display By	LCD+LED
Input Port	4 pin Mini XLR
Controls	Power, mute, group, channel, frequency, sensitivity adjustment, input level attenuation, auto off
Battery	AA alkali battery or MiNH rechargeable battery x 2
Charging	Yes
Dimension	62mm (W) x 80.3mm (H) x 22.6mm (L)

3-4 Optional condenser microphone

Lavaliere microphone // CM-501 CM-201i CM-125i

Model	CM-501	CM-201i	CM-125i
Connector	4-pin mini XLR	4-pin mini	4-pin mini XLR
Frequency Response	100~15,000 Hz	XLR60~15,000 Hz	50~18,000 Hz
Polar Pattern	Cardioid	Omni-directivity	
Sensitivity (at 1000Hz)	$-60 \pm 3\text{dB}$	$-60 \pm 3\text{dB}$	$-53 \pm 3\text{dB}$
Impedance	2.2K Ω		4.4K Ω
Max. SPL for 1% THD	130dB		
Dimension (mm)	$\varnothing 10.1\text{mm (W)} \times 26.4\text{mm (H)}$	$\varnothing 5\text{mm (W)} \times 9\text{mm (H)}$	$\varnothing 4\text{mm (W)} \times 11\text{mm (H)}$
Net Weight	21.5g	20.7g	7g (cable not included)

Headset microphone

Model	CM-214i	CM-214Ui	CM-214ULi
Connector	801C4 (4P Mini XLR)	4P Mini XLR	801C3 (3P Mini XLR) 801C4 (4P Mini XLR) 801CS (3.5 stereo plug)
Option Connector	801C3 (3P Mini XLR) 801CS (3.5 stereo plug) 801CR		801CR
Frequency Response	60~15,000 Hz	30~18,000 Hz	100 ~ 18,000Hz
Polar Pattern	Omni-directional	Cardioid	
Sensitivity (at 1000Hz)	-60±3 dB	-68±3 dB	-65±3 dB
Impedance	1.8kΩ	680Ω	1.8kΩ
Max. SPL for 1% THD	130dB		120dB
Dimension(mm)	125mm(W) x 134mm(H)x 157mm(D)	205mm(W)x 134mm(H)x 157mm(D)	125mm(W)x 134mm(H)x 157mm(D)
Net Weight	32.9g	38.4g	18g (cable excluded)

Model	CM-235i	CX-504
Connector	801C4 (4P Mini XLR)	4P Mini XLR
Frequency Response	50~18,000 Hz	30~18,000 Hz
Polar Pattern	Omni-directional	Cardioid
Sensitivity (at 1000Hz)	-53 ± 3dB	-68 ± 3dB
Impedance	1.8kΩ	680Ω
Max. SPL for 1% THD	130dB	130dB
Dimension(mm)	155mm(W)x 134mm(H)x 157mm(D)	285mm(W)x 55mm(H)x 111.3mm(D)
Net Weight	17g (cable excluded)	56.3g

Ear-hook microphone // CM-801 CM-804i CM-8015 CM-825i

Model No	CM-801 / CM-804i	CM-8015 / CM-825i
Connector	801C4 (4P Mini XLR)	801C4 (4P Mini XLR)
Option Connector	801C3 (3P Mini XLR) 801CS (3.5 stereo plug) 801CR	801C3 (3P Mini XLR) 801CS (3.5 stereo plug) 801CR
Frequency Response	60~15,000 Hz	50~18,000 Hz
Polar Pattern	Omni-directional	Omni-directional
Sensitivity (at 1000Hz)	-64±3 dB	-53±3 dB
Impedance	1.8kΩ	1.8kΩ
Max. SPL for 1% THD	130dB	130dB

Compatible Instrument Microphone // CX-500 CX-500F CX-520 CX-508W CX-516W

Model No	CX-500	CX-500F	CX-520
Connector	4P Mini XLR	4P Mini XLR	4P Mini XLR
Frequency Response	20~20,000 Hz	20~20,000 Hz	50~16,500 Hz
Polar Pattern	Omni-directional	Omni-directional	Supercardioid
Sensitivity (at 1000Hz)	-58±3dB	-58±3dB	-78±3dB
Impedance	1.5kΩ	1.5kΩ	600Ω
Max. SPL for 1% THD	130 dB	130 dB	148 dB
Good For	Violin	Flutes	Harmonica

Model No	CX-508W	CX-516W	
Connector	4P Mini XLR	4P Mini XLR	
Frequency Response	50~18,000 Hz	30~18,000 Hz	
Polar Pattern	Cardioid	Cardioid	
Sensitivity (at 1000Hz)	-67±3 dB	-67±3 dB	
Impedance	220Ω	220Ω	
Max. SPL for 1% THD	130 dB	130 dB	
Good For	Winds	Accordion	

4. Description of parts







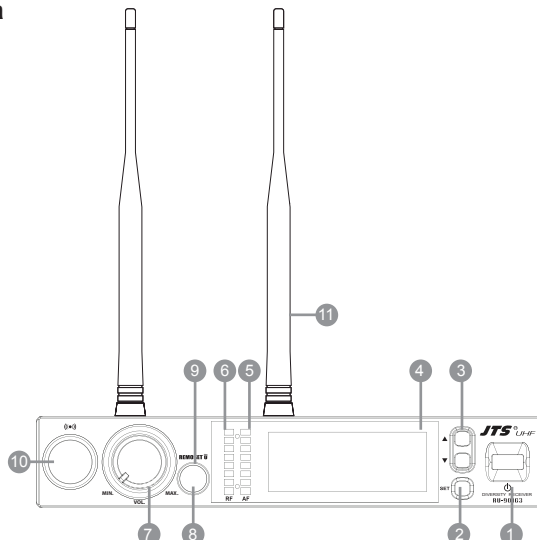

4-1 UHF PLL single-channel diversity receiver(True Diversity) // RU-901G3

Front panel

- ① **Power On/Off switch:** Press once to turn on the power,press and hold for 2 seconds to turn off.
- ② **SET:** this is for function settings. Push and hold for 2 seconds to enter the setting mode. Push "SET" repeatedly to search for the function you wish to set.
- ③ **▲/▼**In the setting mode, push▲/▼to change the function parameter
In the non-setting mode: push▲/▼to adjust volume
- ④ **LCD display**
- ⑤ **AF signal level**
- ⑥ **RF signal level**
- ⑦ **Volume control**
- ⑧ **Remoset Button :** this allows user to synchronize the transmitter after modifying a parameter. Push " **REMOSET** " to synchronize the settings to the transmitter.
- ⑨ **Remoset indicator :** this shows the current pairing status. It flashes rapidly when data is being transmitted and the flashing stops when the synchronization is completed. However, the flashing slows down if synchronization fails after a period of time of pairing attempt.
- ⑩ **Ultrasonic transmission unit:** it transmits digital pairing data at ultrasonic frequency. When setting, direct the ultrasonic receiving element of the microphone to the ultrasonic transmitting unit of the receivers. The effective range is 30° on both sides with the optimized distance at 30cm.
- ⑪ **Antenna**



In the non-setting mode, the LCD looks like :

- 12  : Antenna A/B
- 13  : Transmitter battery level
- 14  : Group/channel
- 15  : Key Lock
- 16  : Receiver mute
- 17  : Output attenuation
- 18  : Squelch level
- 19  MHz : Frequency

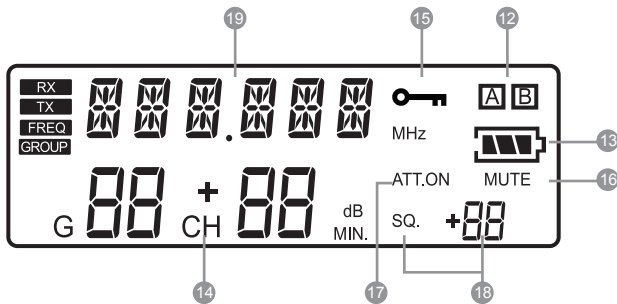

Rear panel

- 20 **DC power socket:** for 12~15V DC / 500mA power supply
- 21 **Female BNC antenna port:** the 50Ω BNC antenna is connected here. It also provides a booster power of 12~15 DC / 100mA for an external antenna booster.
- 22 **6.3mm phone jack:** unbalanced audio output jack
- 23 **3P XLR male:** balanced audio output jack

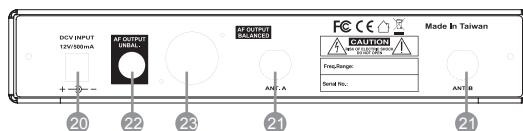

4-2 UHF PLL hand-held transmitter // RU-G3TH

- 1 **Power:** push to turn the transmitter on. When the transmitter is on, push and hold for 2 seconds to turn it off.
- 2 **Mute:** while the transmitter is on, switch Mute up to talk and down to mute. If the transmitter is off, switch the Mute up to turn the unit on. The transmitter turns itself off automatically after 1, 10 or 30 minutes of muting depending on setting.
- 3 **Ultrasonic receiving unit:** it receives pairing signals from the ultrasonic transmission unit at the receiver end.
- 4 **Battery holder:** it holds UM3, AA 1.5V battery or rechargeable battery x 2.
- 5 **LED indicator:** it shows the transmitter's status, including battery level, mute and pairing indication.
- 6 **LCD display:** it shows the parameter settings in the transmitter.
- 7 **SET:** it allows parameter settings, including frequency, group, channel, sensitivity, transmission power, auto off countdown and machine code.
- 8 **▲/▼:** these are used with "SET" to change the parameter settings.
- 9 **→○:** push and hold the "LOCK" button for 2 seconds to lock the buttons. Push and hold again for 2 seconds to unlock.
- 10 **Charging contact:** if rechargeable batteries are used, this microphone can be recharged with an optional charger.

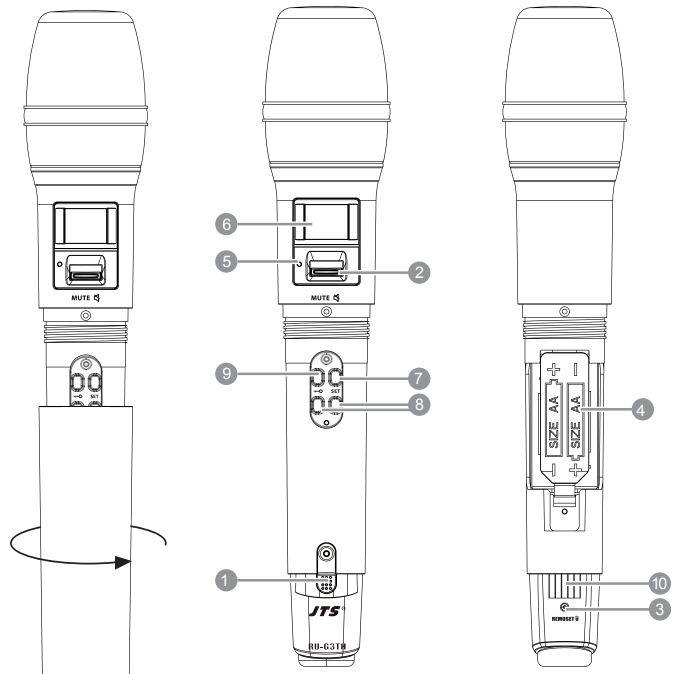

Indicators

Green	Battery > 2V
Flashing green	Microphone mute
Red	Battery ≤ 2V
Alternating red and green	Microphone mute (and battery low)
Blue	Pairing successful
Flashing blue	Data receiving error

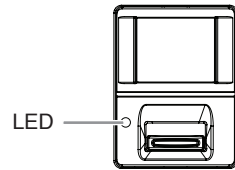

Others

Battery charging is supported. The transmitter turns off automatically when charging.

When battery is < 1.8V, the transmitter will turn off automatically.

If the microphone is turned off with the mute switch on mute, just slide the switch up to turn the microphone on.

4-3 UHF PLL body-pack transmitter // RU-G3TB

- 1 **LCD display**
- 2 **Ultrasonic receiving unit:** it receives the pairing signals from the ultrasonic transmission unit at the receiver end.
- 3 **REMOSET indicator:** Blue : Pairing successful
Flashing blue : Date receiving error
- 4 **Power:**
 - (1)On: push the power button
Off: push and hold the power button for 2 seconds till the display shows "Power Off:"
 - (2)Exit Setting Menu: when in the Setting Menu, push the power button to return to the main screen.
- 5 **▲/▼:** these are used with "SET" to change the parameter settings.
- 6 **SET:** to set and save
- 7 **Mute Switch / LED Indicator :**
 - (1)Show green light when power is on.
 - (2)Show red light when battery level is too low.
 - (3)Flash red light when switch to "MUTE" function to mute the transmitter.
 - (4)Flash red light and green light when mute function is on and battery level is too low.
- 8 **Battery tray**

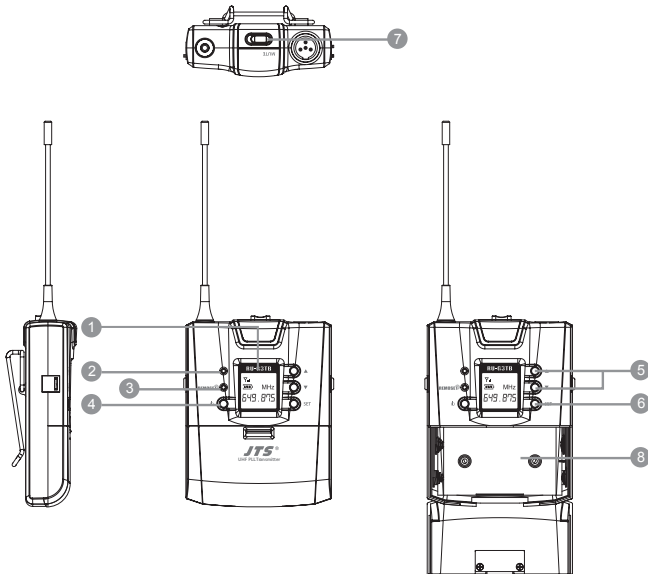

4-4 Optional remote mute switch PT-RMS

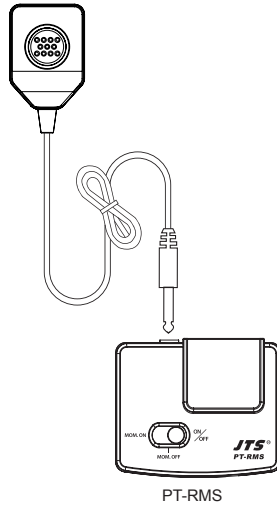

4-5 Optional Condenser Microphone

Lavaliere Microphone // CM-501 CM-201i CM-125i

- ① Clip
- ② 4 Pin Mini XLR
- ③ 3 Pin Mini XLR Option
- ④ 3.5 Stereo Plug Option
- ⑤ 4Pin Hirose connector Option
- ⑥ Windscreen

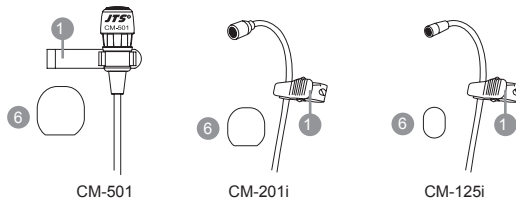

Headset Microphone // CM-214i / CM-214Ui / CM-214ULi / CM-235i / CX-504

- 1 Gooseneck
- 2 Adjustable headband
- 3 Headband
- 4 4 Pin Mini XLR
- 5 3 Pin Mini XLR Option
- 6 3.5 Stereo Plug Option
- 7 4Pin Hirose connector Option
- 8 Windscreen

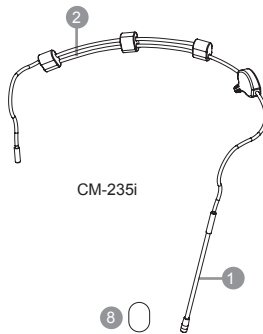
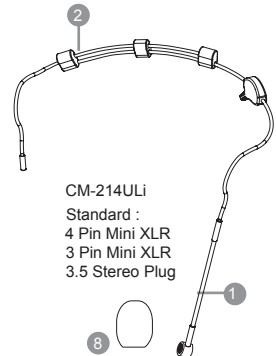
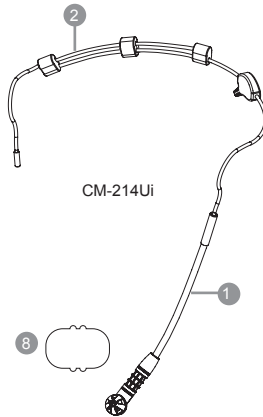
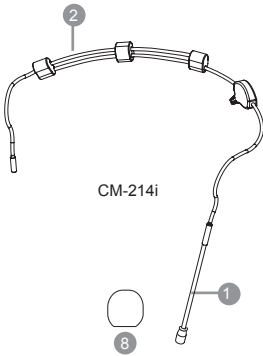
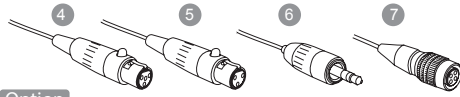

Ear-hook Microphone // CM-801 / CM-804i / CM-8015 / CM-825i

- 1 Boom
- 2 Adjustable Headband
- 3 Adjustable ear hook
- 4 Detachable Cable
- 5 Cable Clip
- 6 Windscreen
- 7 4 Pin Mini XLR
- 8 3 Pin Mini XLR Option
- 9 3.5 Stereo Plug Option
- 10 4Pin Hirose connector Option

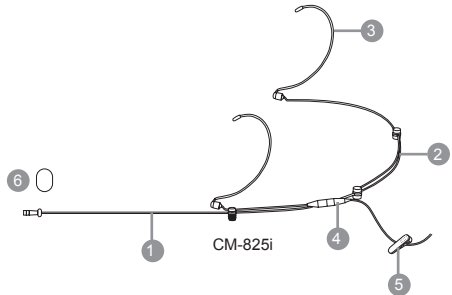
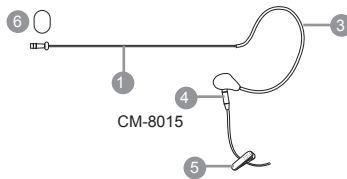
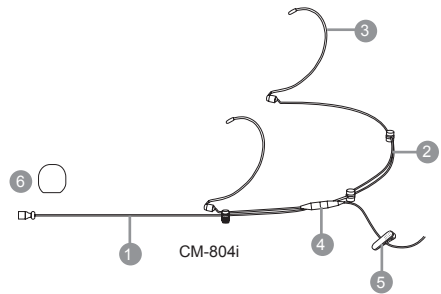
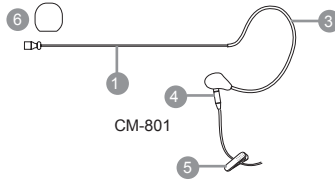
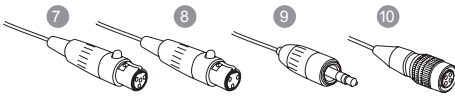

Compatible Instrument Microphone // CX-500 / CX-500F / CX-520 / CX-508W / CX-516W

- ① Gooseneck
- ② Clip
- ③ Bracket
- ④ Volume Control
- ⑤ Windscreen
- ⑥ 4 Pin Mini XLR

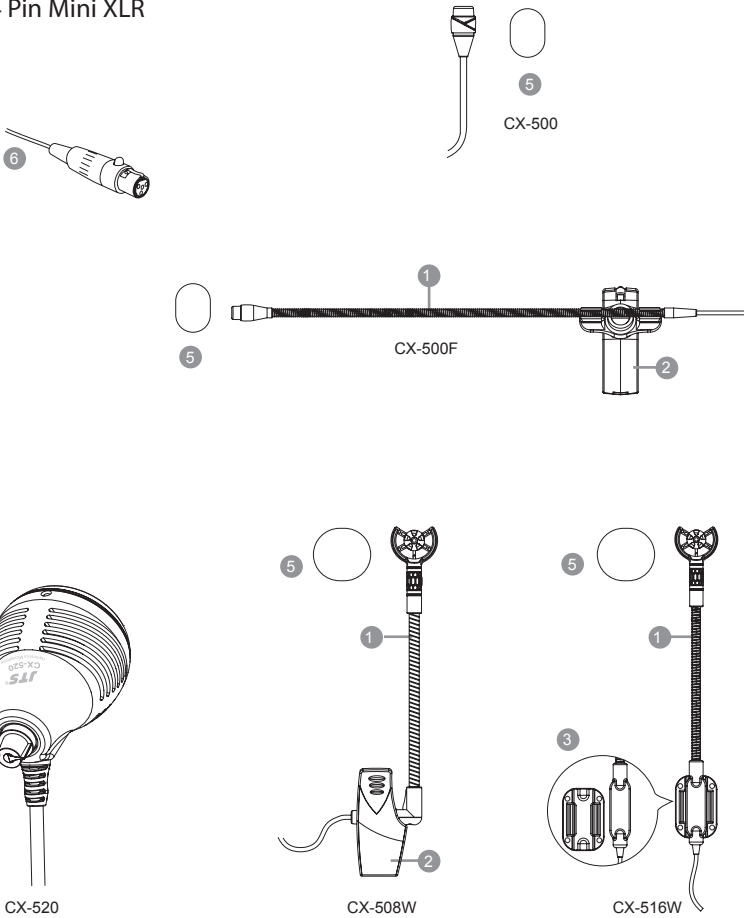

4-6 Accessories

- 1 AC/DC adaptor
 - A Switching Power Supply(100V~240V , 50~60Hz)
 - B Linear Power Supply (220V , 50Hz) Option
 - C Linear Power Supply (220V , 60Hz) Option
- 2 Screwdriver
- 3 DR-900 Dual Rack Adaptor Option
- 4 RM-901 Rack Mount Kit Option
- 5 RP-900 Panel Cover Option
- 6 AF output cable (with $\Phi 6.3$ plug at both ends)
- 7 GC-80/GC-100 Guitar Cable Option
- 8 GC-80L/GC-100L Guitar Cable Option

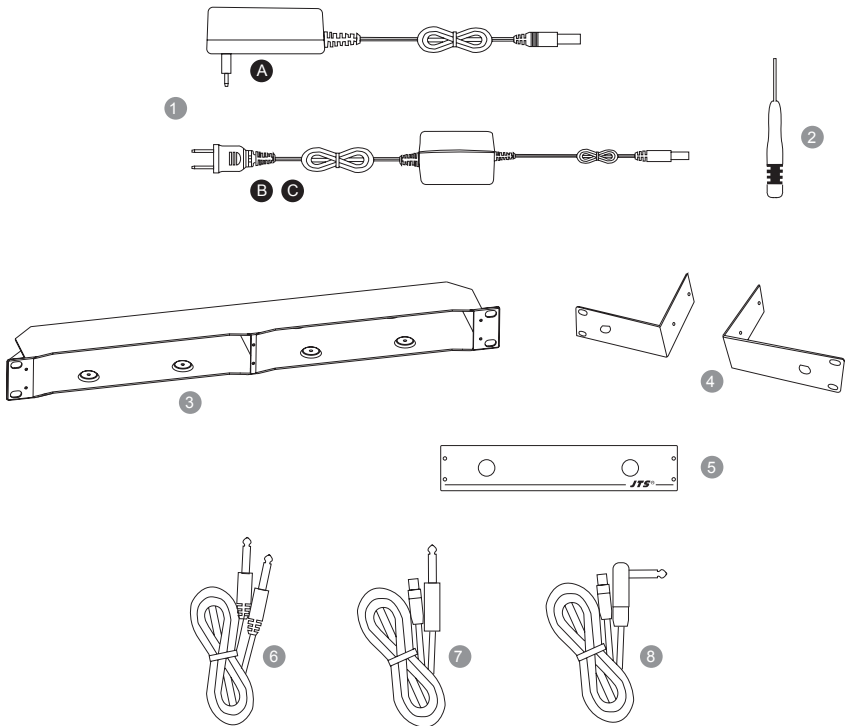

5. Preparing Procedures

5-1 How to connect the receiver// RU-901G3

(1) Power output connector

Plug in one end of AC/DC adaptor cable to DC input socket in the rear panel of receiver, and plug another end into an AC outlet.(Step 1)

(2) Audio Output Connector

Connect one end of the AF output cable to the AF output socket in the rear panel, then plug another end to the "MIC IN" input socket of a mixer or amplifier. (Step 2)

Receiver e quipped with balanced XLR output and Unbalanced Ø6.3mm output, choose the proper way for use.

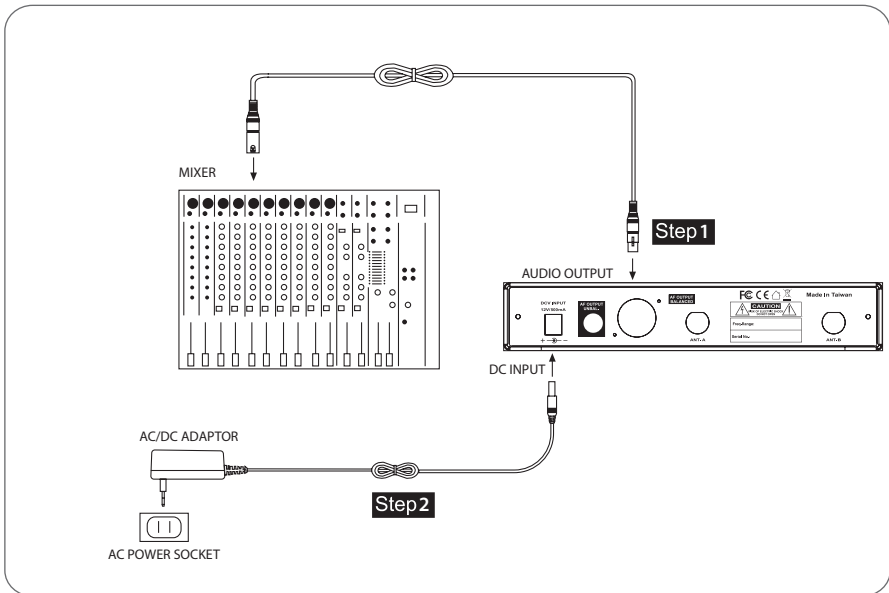

5-2 Transmitter installation // RU-G3TH

The Mute button on the hand-held unit also triggers the power-on. That's why the unit is on as soon as the batteries are replaced. Therefore, if you do not wish to turn on after changing the batteries, keep the Mute switch on mute.

1. Unscrew the outer tube of the transmitter (Figure 1).
2. Place 2 AA batteries in the battery holder while make sure they are in the correct polarities (Figure 2).
3. Screw the outer tube on (Figure 3).
4. To turn the unit on:
 - a. Push the power button to turn on (Figure 4a), or
 - b. Push the Mute switch up also to turn the unit on (Figure 4b).
5. Set the transmitter parameters according to the instructions.

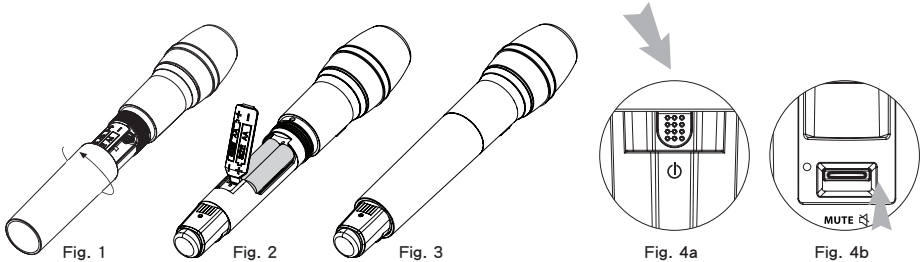

G3TB

1. Slide the battery holder cover downwards (Figure 1).
2. Place 2 AA batteries in the battery holder while make sure they are in the correct polarities (Figure 2).
3. Slide the battery holder cover upwards to close (Figure 3)
4. According to the type of microphone, insert the 4-pin mini XLR jack in MIC IN to complete the installation (Figure 4).
5. Push the Power button to turn the unit on (Figure 5).
6. Set the transmitter parameters according to the instructions.

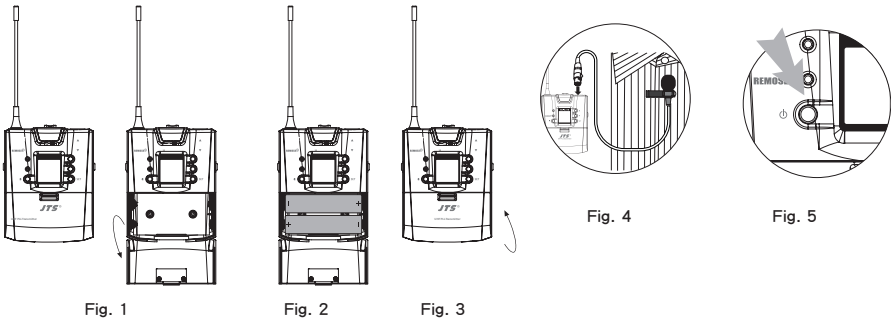

6. Instructions for use

6-1 How to use// RU-901G3

Parameter setting

Push and hold the "SET" button to enter the setting mode. Push the ▲/▼ button to choose to set RX (receiver) or TX (transmitter).

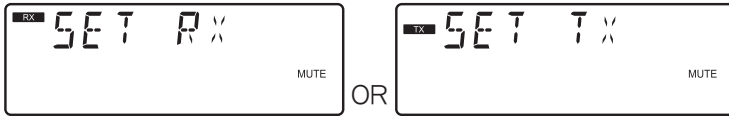

When RX receiver is selected:

◎ FREQ: frequency setting

In 1MHz	Select frequency with ▲/▼
In 0.025MHz	Select frequency with ▲/▼



Select the number of frequency first in MHz and then in 0.025MHz.

◎ Group / channel

G: group	Select default group 1~6
CH: channel	Select default channel, 1~23 max

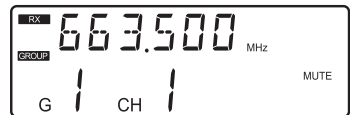

Select the group when "G" is flashing; select the channel when "CH" is flashing.

◎ SQ Receiving sensitivity

-5~+10dB; select SQ with ▲/▼	-5 is the maximum sensitivity.
	+10 is the minimum sensitivity.
	The default setting is 0.



The default setting is 0.

© Channel scan

SCAN oF	This means the function is deactivated.
SCAN on	This means the function is activated. (scan to make sure this channel is occupied or not. The program will avoid it automatically to prevent interference.)

Note: this function works only in the preset mode.



This function is deactivated.

© Audio output attenuation (XLR)

ATT oF	No attenuation at audio output
ATT on	20dB attenuation at audio output



This function is deactivated.

© Key lock

LOCK on	Lock ON
LOCK oF	Lock OFF



When TX transmitter is selected:

© Microphone input sensitivity

Normal sensitivity	GAIN : +15dB
	GAIN : +12dB
	GAIN : +9dB
	GAIN : +6dB
	GAIN : +3dB
	GAIN : 0dB (default)
	GAIN : -3dB
	GAIN : -6dB
	GAIN : -9dB
	GAIN : -12dB
	GAIN : -15dB



It shows the microphone input sensitivity is now at 0dB (default setting).

⊙ ATT microphone audio input attenuation

ATT oF	No attenuation at audio input
ATT on	20dB attenuation at audio input (depending on whether the transmitter is provided with the corresponding function).



The function is activated with 20dB of audio input attenuation.

⊙ RFP: RF microphone power

The transmitter comes with 2 stages of RF power output (as per local regulations).

Lo	10mW
Hi	50mW



This shows that the RF output is LOW (10mW)

⊙ ATOF: Automatic microphone off countdown under mute status

OF	This function is deactivated
1	1 minute countdown to turn off
10	10 minute countdown to turn off
30	30 minute countdown to turn off

(The default setting is 10 minute.)



This function is deactivated.

⊙ RC (Remoset Configuration)

RC FRE	Only frequency and group setting will be synchronized
RC ALL	All data setting will be synchronized

The default setting is rC-FRE.

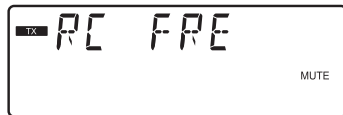

Only frequency and group setting will be synchronized.

Pairing **REMOSET**

Once the parameters are set, push the “ **REMOSET**  ” button and the digital pairing data will be sent to the transmitter via ultrasonic transmitter for parameter synchronization. The indicator will flash rapidly while the data are being transmitted. When the synchronization is completed, the receiver will receive the corresponding data and the indicator will stop flashing. If the signal is not received for a certain period of time, the indicator will flash slowly to inform pairing failure (the slowly flashing indicator can be reset by pushing any button).

Note: The best pairing distance is 10~50cm, $\pm 30^\circ$.

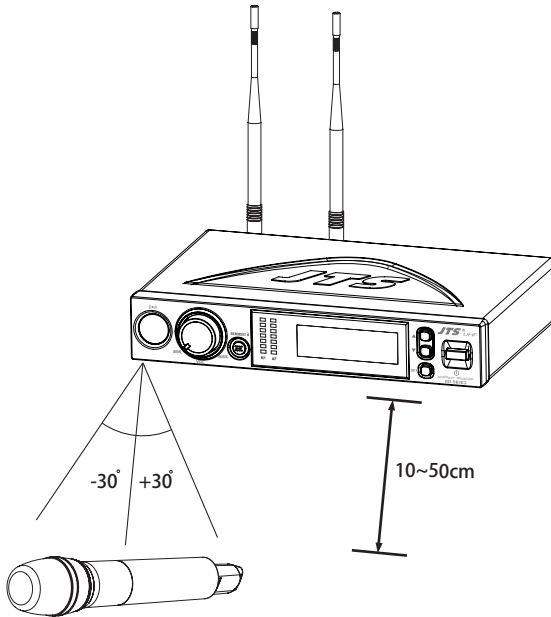

Others

The transmitter's battery level is also shown on the LCD display. If the battery level is $\leq 2V$, the frame around the battery level will flash and the backlight turns into red as a warning.

6-2 How to use// RU-G3TH/G3TB

Push and hold the SET button for 2 seconds to enter the setting mode, and push the▲/▼button to select different parameters. Push the SET button again to save and exit the setting mode.

◎ FREQ: frequency setting

In 1MHz	Select frequency with ▲/▼
In 0.025MHz	Select frequency with ▲/▼

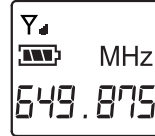

Select the number of frequency first in MHz and then in 0.025MHz.

◎ Group / channel

G: group	Select default group 1~6
CH: channel	Select default channel, 1~23 maxSelect default channel, 1~23 max



Select the number for group and then the number for channel.

◎ Microphone input sensitivity

Normal sensitivity	GAIN : +15dB
	GAIN : +14dB
	GAIN : ?
	GAIN : +2dB
	GAIN : +1dB
	GAIN : 0dB (default)
	GAIN : -1dB
	GAIN : -2dB
	GAIN : ?
	GAIN : -14dB
	GAIN : -15dB

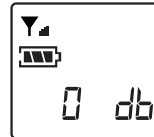

It shows the sensitivity is now at GAIN 0dB (default setting).

◎ ATT microphone audio input attenuation

Att oFF	No attenuation at audio input
Att on	20dB attenuation at audio input

Only for RU-G3TB



It shows the audio input attenuation at 20dB.

◎ RFP: RF microphone power

rFP Lo	10mW(default)
rFP Hi	50mW



The RF output is LOW.



The RF output is Hi.

◎ AUTO-OFF: Automatic microphone off countdown under mute status

OFF	This function is deactivated
1	1 minute countdown to turn off
10	10 minute countdown to turn off
30	30 minute countdown to turn off

(The default setting is 10 minute.)

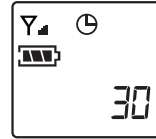

◎ Key Lock

Loc On	Lock ON
Loc OFF	Lock OFF



Others

Battery charging is supported. The transmitter turns off automatically when charging.

When battery is < 1.8V, the transmitter will turn off automatically.

If the microphone is turned off with the mute switch on mute, just slide the mute switch up to turn the microphone on.

6-3 Installation of Condenser Microphones

(1) Lavalier microphone

Attach lavalier microphone to a tie, lapel, where is suitable for sound pick-up. Plug the connector into input socket on the body-pack transmitter.

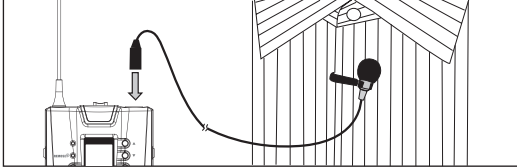

(2) Headset microphone

Put the headband behind your head, and fix the temples on your ears as shows, then adjust the gooseneck to have best miking. Plug the connector into input socket on the body-pack transmitter.

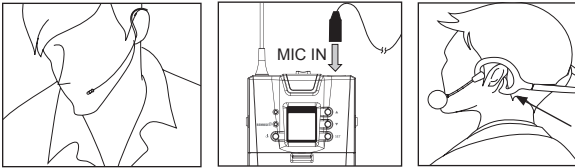

(3) Instrument Microphones

The system is compatible with JTS various instrument microphones. For detail please refer to user's manuals of these microphones.

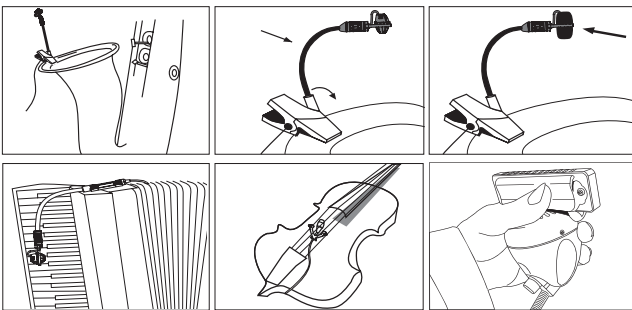

(4) Ear-hook Microphone

1. Lightweight Dual Ear Hook Microphone

Try on whether the headset is fit.

Adjust the headband to a suitable width.

Tighten or loosen the curve of the ear-hook by twisting the loop or expanding it.

Curve and bend the boom to fit your face.

Attach the detachable cable to a suitable place by a cable clip.

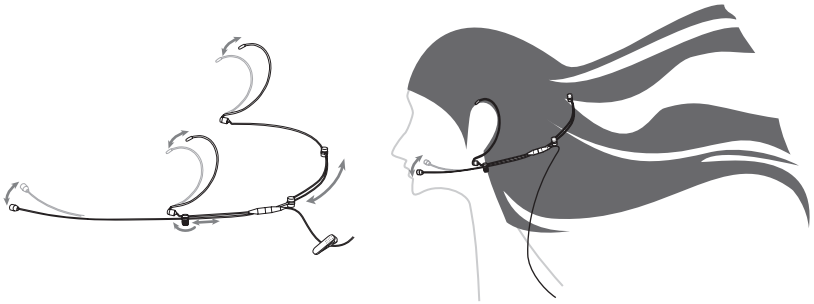

2. Lightweight Single Ear Hook Microphone

Try on whether the original curve is tight or loose.

Re-try and push the fixed curve against your earlobe.

Curve and Bend the boom to fit your face.

Attach the detachable cable to a suitable place by a cable clip.

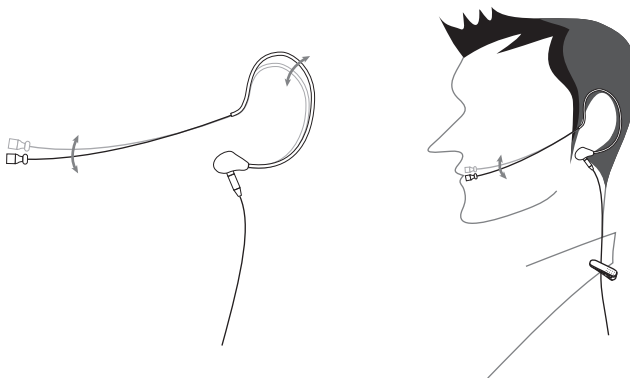

7. Notes for the product

- (1) For the best signal receiving quality, always keep the receiver within 3m of the transmitter.
- (2) The receiver and transmitter shall be away from other metal objects, preferably 50cm or farther.
- (3) Do not point the microphone directly to a speaker, or there will be feedbacks.
It is recommended to hold the transmitter (microphone) at the middle section for the best pickup.
- (4) In case that the transmitter will not be in use for an extended period of time, the batteries shall be removed from the battery holder to prevent damage to the transmitter due to leak of battery electrolyte solution.
- (5) For the best power performance, it is recommended to change both batteries or use the products of the same manufacturer when they are to be changed.