

User Manual

MODEL: HPI212S

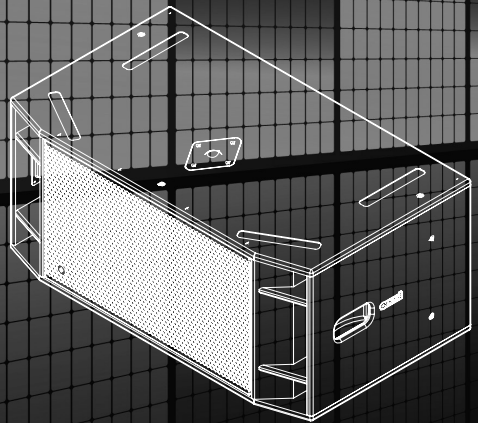

Contents

Safety Precautions	1
General Description	3
Getting The Best From Your HPI212S	4
Flying Your System	6
HPI212S Specifications	8
HPI212S Reference Diagram	9

Safety Precautions

- Be sure to read the instructions in this section carefully before use.
- Make sure you observe the instructions in this manual as the conventions of safety symbols and messages are very important.
- We also recommend you keep this instruction manual handy for future reference.

Safety Symbol and Message Conventions

Safety symbols described below are used in this manual to prevent bodily injury and property damage which could result from mishandling. Before operating your product, read this manual first and understand the safety symbols and messages so you are thoroughly aware of any risks.



WARNING

Indicates a potentially hazardous situation which, if mishandled, could result in death or serious personal injury.





WARNING

When Installing the Unit

- Flying and/or installation of this speaker cabinet must be carried out by suitably qualified personnel following the locally authorised and approved safety standards.
- Do not expose the unit to rain or an environment where it may be exposed to water or other liquids, as doing so may result in damage to the bass driver or corrosion of the steel protective grill.
- Do not cut, kink, otherwise damage nor modify the speaker cable. Also use speaker cable of at least 1.5mm core diameter. In addition, avoid locating the speaker cables close to heaters, high traffic areas or locations where the cables can be damaged.
- Avoid installing or mounting speaker boxes in unstable locations and when flying, use the hardware designed for the speaker box and fix securely to a solid wall. Failing to do so may result in the unit falling, causing personal injury and/or property damage.
- Be sure to ground to the safety ground (earth) terminal to avoid electric shock. Never ground to a gas pipe as a catastrophic disaster may result.
- Never hang a speaker box from only one rigging point. Use multiple points and attach a safety line to a point strong enough to take the weight of the speaker box.

When the Unit is in Use

- Turn down amplifiers before switching on the system. If there is no sound, check the speaker connections. Speakon connectors must be locked in place.
- Should any of the following irregularities be found during use, immediately switch off the amplifier power, disconnect the power supply plug from the AC outlet and contact your nearest Quest dealer:
 - If you detect smoke or a strange smell coming from the unit,
 - If the unit falls and the unit case is damaged,
 - If it is malfunctioning (no low frequency output).

Make no further attempt to operate the unit if it is found to be in any of the above conditions as this may cause fire or electric shock.

2



WARNING

Flying the box from one insert must not be attempted! Improper installation may result in damage, injury or death.

General Description

The HPI212S is designed for the permanent installation and live sound touring market.

It is suited to mid to high sound pressure level bass and sub bass high fidelity reproduction as a stand-alone unit or in combination with the 18" HPI18LP sub bass as a multi-way sub bass system.

Versatile and Functional

The HPI212S sub bass is primarily intended to deliver sub bass support to the HPI-110/210 speaker system but it can also be deployed with any medium format speaker array or distributed system where extended high output sub bass is required from a compact enclosure.

Please read and become familiar with the following installation manual to get the best results from your Quest HPI series speakers.

All Quest HPI series speakers are designed and for the high end professional live sound industry. However they will give better results if they are installed and operated within standard industry practice. Pay particular attention to the section on "Overhead installation and rigging" if you are flying an array of speakers or flying the sub bass.

Features

The HPI212S has a number of features designed to increase performance and versatility for a professional mobile sound or permanent installation environment. A great deal of attention was paid to the details of the design to make the HPI212S both sonically excellent and functionally suited to touring sound reinforcement and also A/V rental markets.

The compact design makes it possible to locate the HPI212S under a stage. The back input panel is located on a recessed and sloping panel intended to relieve the strain on the input cable and also make it possible to locate the sub cabinet against a wall.

Solid Build Construction

Built for a touring environment, the HPI212S is well suited to all professional applications.

Like all Quest products, it is "built tough for a tough world".



Getting The Best From Your HPI212S

Connections

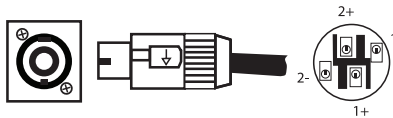

Two NL-4 connectors are mounted in a recessed panel on the rear surface of the box. This allows the speaker box to be set flat against a wall without physical interference to the speaker connector.

- The connector input is wired pin 1+ and pin 1-.
- Pin 2 is not connected.

Take care when inserting the Speaker connector twisting the connector until it locks into place. Reverse the procedure to disconnect.

4

Reducing low frequency output below 35 Hz will make more amplifier power available for the audible bass frequencies and help to prevent the 12" drivers from excessively heating up.

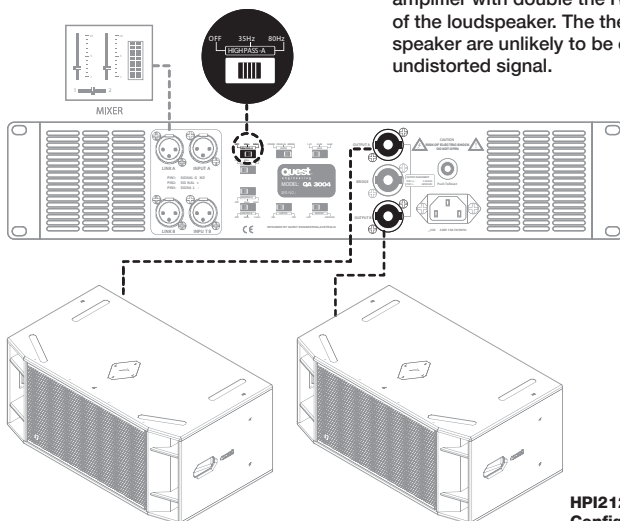

HPI212S in Recommended Configuration (4 ohm)

Amplification

The performance of any loudspeaker depends on the amplifier delivering an adequate supply of clean power.

Please ensure a suitable amplifier is selected for use in conjunction with the HPI212S and accompanying speaker system.

Power in the Right Hands Can Save Your Speakers

If the loudspeakers are used for a professional application with competent operators, the power principle is as follows:

When the loudspeaker is needed to achieve maximum output levels, the amplifier should be able to sustain a peak of twice the wattage listed in the loudspeaker specifications. A quality amplifier will provide a clean peak voltage capability of 6 dB above the maximum RMS power of the amplifier.

To avoid "clipping" or distorted output from a lesser quality amplifier, select an amplifier with double the RMS power rating of the loudspeaker. The thermal limits of the speaker are unlikely to be exceeded with an undistorted signal.

Avoid Amplifier Clipping

Bearing in mind the previously described principle of amplifier power being higher than speaker power, keep signal levels low enough so that neither the Clip or Limit Active indicators are blinking frequently or are on continuously. If they are, turn down the input signal level.

A low power amplifier that is clipping will quickly damage the loudspeaker.

The Secret to Long Life

A competent audio system operator will operate the loudspeaker within its limits.

Operation beyond the loudspeaker's capabilities usually includes, but is not limited to, one or more of the following conditions:

1. Amplifier clipping
2. Noticeable distortion
3. Mechanical noise (such as a cone bottoming out)
4. The gain to the amplifiers is increased with no audible increase in sound pressure level (power compression).

At a minimum, the operator should have a meter display on the mixing desk calibrated to indicate where the amplifier's maximum RMS voltage limits will be reached.

How to Calibrate the Mixer VU Meter

With the loudspeakers disconnected, turn up the mixer with program music until the mixer VU meter indicates +3dB on peak. Check the amplifier status lights and if the clip light appears intermittently the VU meter will be a guide as to available amplifier power.

The purpose of this test is to determine at what point of the mixer VU amplification, the amplifier is at full power. Depending on signal path, this could be anywhere between 0dB and +6 on the mixer VU.

Finding a Suitable Amplifier

The HPI212S is a 4 ohm enclosure.

A recommended minimum power range per amplifier channel is 1,000 watts RMS into a 4Ω load.

An ideal partner for the HPI212S is the Quest QA3004 as each channel is capable of providing more than 1,000 watts RMS into a 4Ω load.

For any application where the HPI212S is to be used in parallel mode, ensure the amplifier is capable of providing up to 2,000 watts RMS into a 2Ω load.

Setting the QA amplifier's high pass filter at 35Hz is recommended for clean high SPL applications.

Loudspeaker Wire Gauge

The proper conductor size (wire gauge) to use for the loudspeaker cable is primarily a function of the wire length. The general rule is that lower resistance, in relation to the loudspeaker's impedance, is better. To achieve this, use larger conductor sizes for longer lengths of cable and for lower impedance loudspeaker loads. For wiring cables to sub bass boxes, 2.0 - 2.5mm 14 Gauge would be the minimum for short cable runs.

Standard AWG

- 14ga ... 0.6410" dia = 1.63mm dia
10.44ohm/km
- 16ga ... 0.0508" dia = 1.29mm dia
13.17ohm/km
- 18ga ... 0.0403" dia = 1.02mm dia
20.94ohm/km

Euro Standard Wire

- 1x1.00mm2 = 18 ga AWG
- 1x1.50mm2 = 16 ga AWG
- 1x2.50mm2 = 14 ga AWG
- 1x4.00mm2 = 12 ga AWG



Flying Your System

Overhead Installation and Rigging

“Rigging” is used in this manual as a general term referring to fixed mounting or hanging suspension as well as the hardware used for such mounting and suspension. It also applies to temporary and permanent installation.

Mounting or rigging overhead suspension of any speaker box load can result in serious injury and equipment damage if not done correctly. Rigging and installation personnel must determine the mounting or suspension method that takes into consideration all loads that the speakers and rigging system will be subjected to. All such work must be done in accordance with and in compliance with all government, state, and local regulations governing such work.

6

NOTE: The user assumes all responsibility and liability for the proper design, installation, and use of any rigging and mounting systems for Quest Engineering loudspeakers.

NOTE: Accessory items are available from Quest Engineering and aftermarket suppliers to facilitate suspension, wall, ceiling, or other rigging. When using these items, review all enclosed documentation and carefully follow all instructions and safety precautions.

Purchaser/Installer Responsibility

It is the responsibility of the purchaser and end-user of Quest Engineering products to:

1. Read the product instructions and labels and follow them.
2. Inspect the product immediately upon receipt as well as before and after each use.
3. Receive training in the proper installation and use of the equipment. Proper training includes safety procedures, limitations of the equipment, inspection of the equipment, and risk management. If you are not competent in the use of a product, do not use it.
4. Determine if the product is suitable for its intended use and that it meets all applicable standards and regulations.
6. Use adequate back-up rigging safety systems.

Rigging and Safety

Whether mobile sound or fixed installation, for best and safest results your speakers need to be installed and positioned correctly. Placing a mid-high on a sub bass and pointing it at the crowd does not ensure safety if the speaker vibrates and falls off the stage and into the audience. This also applies when hanging a box from a lighting bar with non rated hardware.

Only a professional installer with extensive and proven knowledge of load limits and weight ratings attempts flying any loudspeaker product.



WARNING

Use a thread retention compound such as “Loctite” to make sure the bolts are firmly secure and cannot become loose.

Maintenance of Rigging

Suspension systems can degrade with time, exposure to atmospheric conditions and wear, they require regular inspection and routine maintenance to insure the speaker cluster and fittings are secure. The installation must be inspected for fatigue at least annually. The inspection must include a survey of all load bearing surfaces including those attached to the building for signs of deterioration or any other condition that may decrease the strength of the installation or loudspeaker enclosure.

Quest Engineering or its distributors are not responsible for the non legal application or misuse and abuse of its products by installers and product users.

HPI212S Rigging Points

The HPI-212S casing contains 10 internal threaded inserts for flying the box. Rated M8 eye bolts can be attached to the casing for flying the box in a permanent installation.

The HPI212S as Part of a Larger System

The HPI series is designed to be multi-functional. Both the HPI212S and HPI18LP can be used as a stand alone sub bass or independently crossed over, as band pass elements in a multi-way system.

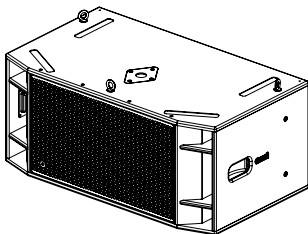

Drawing of HPI212S with eye bolt fly points

When used in conjunction with a HPI-212S, the HPI212S can be band-passed with an electronic x-over to reproduce a very low frequency range to provide the very low sub bass of electronic music and the HPI-212S can be set at a frequency range to provide the “punch”. The ideal frequency range to set the individual box element is as follows:

HPI212S band-passed 75-120 Hz.

HPI18LP band-passed 30-75 Hz.

The filter type needs to be a 24 dB per octave slope.

Depending on the method of installation and room acoustics, minor variations to these settings may be necessary for ideal results.

The HPI Ground Stack Footprint

The physical footprint allows the HPI212S to interlock with the HPI18LP in a ground stack. Up to three HPI110 or HPI210 box elements can be stacked in a ground stack array.

7



CAUTION

It is strongly advised to attach the array flying plate to the top of the ground stacked boxes to prevent any box elements being dislodged from the ground stack. A ratchet strap can also be used to secure the boxes.



WARNING

Do not attach the HPI212S to the HPI110 box inserts if flying the sub bass as part of a flown array.

HPI212S Specifications

Typical Frequency Response

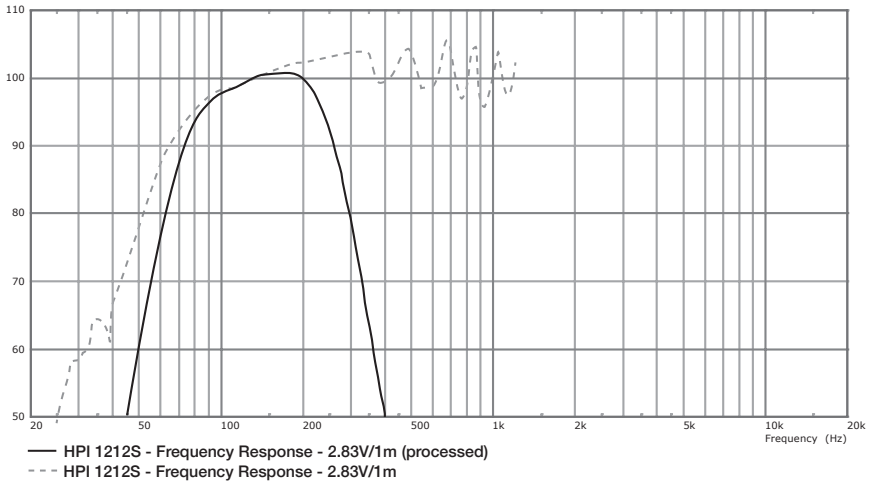

Technical Specifications

Power Handling	1000 W rms
Frequency Response	45-250 Hz
Sensitivity	93.5 dB
Maximum SPL @ 1m	131 dB
Impedance	4 ohms
Connections and Wiring	Input 1+/- ; Through 2+/-
Woofers	12 inch Ferrite (x2)
Dimensions	900 x 520 x 395 mm
Weight	36.5 kg net

HPI212S Reference Diagram

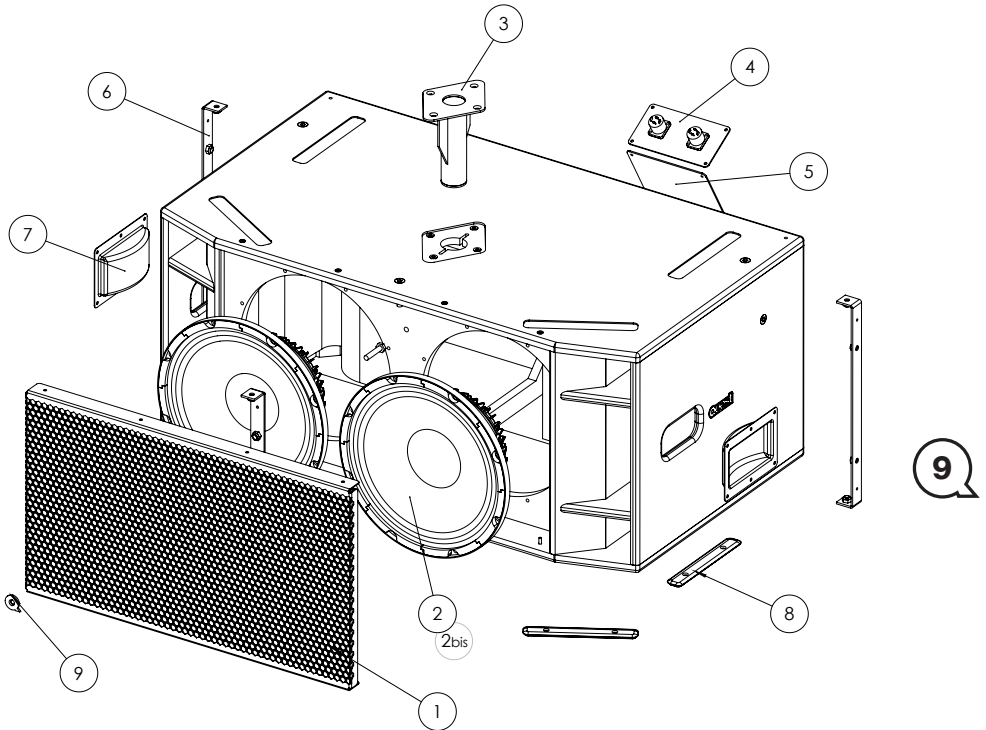

No.	Description	Spare Part
1	Complete Grille (inc. foam)	HGHPI212S
2	12" Woofer (x2)	T12007
2bis	Recone Kit for 12" Woofer	RT12007
3	Top Hat	HTHHPI
4	Connection Plate (inc. Connectors)	HCP212S
5	Manufacturer Plate	HMP212S
6	Internal Metal Brace (x3)	HIB212S
7	Rubber Skid 182mm	HSK182

Register Your Product

Thank you for choosing Quest. Please take the time to complete your product registration card which is included with the packaging.

Registering your Quest Engineering product will:

- CONFIRM YOUR WARRANTY
- REGISTER YOUR PRODUCT
- PROTECT YOUR NEW PRODUCT

REGISTER ONLINE:

www.questaudio.net/registration

quest[™]
engineering

www.questaudio.net