

# User Manual

MODEL: HPI 110

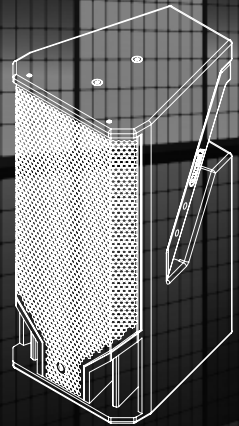

# Contents

---

<b>Safety Precautions</b> .....	<b>1</b>
<b>General Description</b> .....	<b>3</b>
<b>Getting The Best From Your HPI110</b> .....	<b>4</b>
<b>Flying the HPI110</b> .....	<b>6</b>
<b>HPI110 Specifications</b> .....	<b>8</b>
<b>HPI110 Reference Diagram</b> .....	<b>9</b>

## Safety Precautions

- Be sure to read the instructions in this section carefully before use.
- Make sure you observe the instructions in this manual as the conventions of safety symbols and messages are very important.
- We also recommend you keep this instruction manual handy for future reference.

## Safety Symbol and Message Conventions

Safety symbols described below are used in this manual to prevent bodily injury and property damage which could result from mishandling. Before operating your product, read this manual first and understand the safety symbols and messages so you are thoroughly aware of any risks.



### **WARNING**

Indicates a potentially hazardous situation which, if mishandled, could result in death or serious personal injury.





## WARNING

### When Installing the Unit

- Do not expose the unit to rain or an environment where it may be exposed to water or other liquids, as doing so may result in damage to the bass driver or corrosion of the steel protective grill.
- Do not cut, kink, otherwise damage nor modify the speaker cable. Also use speaker cable of at least 1.5mm core diameter. In addition, avoid locating the speaker cables close to heaters, high traffic areas or locations where the cables can be damaged.
- Avoid installing or mounting speaker boxes in unstable locations and when flying, use the hardware designed for the speaker box and fix securely to a solid wall. Failing to do so may result in the unit falling, causing personal injury and/or property damage.
- Be sure to ground to the safety ground (earth) terminal to avoid electric shock. Never ground to a gas pipe as a catastrophic disaster may result.
- Never hang a speaker box from only one rigging point. Use multiple points and attach a safety line to a point strong enough to take the weight of the speaker box.

### When the Unit is in Use

- Turn down the amplifier before switching on the amplifier. If there is no sound, check the speaker connections. Speaker connectors must be locked in place.
- Should any of the following irregularities be found during use, immediately switch off the amplifier power, disconnect the power supply plug from the AC outlet and contact your nearest Quest dealer:
  - If you detect smoke or a strange smell coming from the unit,
  - If the unit falls and the unit case is damaged,
  - If it is malfunctioning (no HF or low frequency output).

Make no further attempt to operate the unit if it is found to be in any of the above conditions as this may cause fire or electric shock.

2



## WARNING

Flying the box from one insert must not be attempted!  
Improper installation may result in damage, injury or death.

## General Description

The HPI 110 is a full frequency range multi-purpose 2-way passive speaker system designed for the live sound touring and permanent installation market.

It is suited to full range front-of house sound for mid-throw applications in both stand alone applications or as part of a small array. Its versatility means it can also be configured in multiple numbers as a multi-way system with sub bass enhancement or individually as part of a compact portable full range system with single sub bass enhancement. (See HPI Series bass speaker systems).

The HPI 110 requires no special system processor and installed in a vertical installation, provides both wide dispersion and long throw coverage due to the asymmetrical coverage pattern of the mid/HF wave-guide.

## Features

The HPI 110 has a number of features designed to increase performance and versatility for a professional sound installation environment. A great deal of attention was paid to the details of the design to make the HPI 110 both sonically excellent and functionally suited to all aspects of mobile and permanently installed sound reinforcement.

### High Powered Purpose Designed Components

A very high powered three inch voice coil high frequency driver matched to the 1.5 inch exit high frequency asymmetrical wave guide. The result is a reliable and high fidelity high frequency response with a long throw capability.

The high efficiency 10" neodymium magnet mid-bass transducer has been designed to function in a relatively large volume enclosure to maximize low frequency output. The cone geometry and driver dynamic parameters are also engineered to give a smooth frequency response into the vocal range.

Good vocal and midrange response makes the HPI-110 an exceptional performer when it comes to vocal projection and reproduction of acoustic instrumentation.

### Functional Design

For easy maneuvering and loading, an integrated carry handle also doubles as part of the rigging system and also serves to give the casing more strength and rigidity.

The recessed input panel allows for protection of the plastic Speakon connectors and also aids a visually tidy installation.

### Solid Build Construction

Built for a touring environment, the HPI 110 is well suited to all professional applications. The timber casing is reinforced birch ply with a heavy gauge power-coated steel grill. Like all Quest products, it is "built tough for a tough world".



## Getting The Best From Your HPI110

### Connections

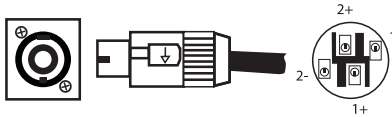

Two Neutric Speakon model NL-4 connectors are mounted in a recessed panel on the rear surface of the box. This allows the speaker box to be set flat against a wall without physical interference to the speaker connector.

- The connector input is wired pin 1+ and pin 1-.
- Pin 2 is not connected.

Take care when inserting the Speakon connector twisting the connector until it locks into place. Reverse the procedure to disconnect.

### Suitable Amplification

The HPI-110 is an 8 ohm enclosure and can be connected in multiple parallel connections to an amplifier channel that can operate at speaker impedances of 4 ohms. A third speaker box can be connected in parallel if the amplifier can operate into loads of less than 4 ohms. The HPI110 is a mid power level high efficiency system, so ultra high power is not necessary to obtain high sound pressure levels. The recommended power range per amplifier channel is 480-720 watts RMS into an 8 ohm load. The HPI-110 is ideal for use with any of the Quest QA amplifier range.

Setting the QA amplifier's high pass filter at 35Hz is recommended for full range applications. If you are intending to add sub bass speakers or use for mainly vocal reproduction, the high pass filter can be set to 80Hz.

Reducing low frequency output will make more amplifier power available for clean vocal reproduction for full range sound, set the high pass filter to 35Hz

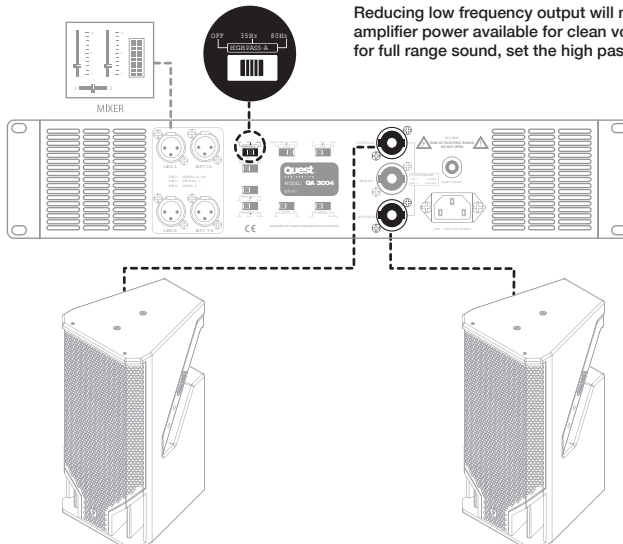

**Recommended HPI110  
Amplifier Configuration**

4

**Speaker cables**

Speaker cable needs to be as heavy gauge as conveniently possible for low-loss results. Light gauge cable (below 1.5mm) will create extra resistance and waste amplifier power. This particularly applies to long speaker runs. The amplifier’s damping factor statistic (“punch” for the non technical) is greatly diminished, so keep your speaker cables short and as heavy gauge as practical.

**Speaker Placement as a Single Box or in Arrays**

The HPI110 is intended for use as a single speaker system or as part of a multiple speaker setup with or without sub bass reinforcement. It can also be installed in small arrays of up to three boxes per array for very wide coverage applications. When a group of wide point source speaker boxes are placed together, it is possible to have “interference effect” between some of the boxes causing uneven frequency response. This can be particularly noticeable in the mid-high frequency area. If you intend to set up the HPI110 as part of a multiple box array, see the section ‘Flying the HPI110’.

When positioning the speaker system on a stage, make sure the HF horn at the top of the speaker box is above the heads of the audience. At full power the output of the HPI110 is very high and hearing damage can result from short to medium term exposure. When used as a drum-fill monitor on a stage, the box can sit on the stage however consider that the HF horn will be at ear level for the average drummer setup.

For best results when the HPI110 is used as a front of house speaker, consider angling the box forward slightly to direct the HF horn to cover the audience area. The HF horn should be aimed away from the ceiling and focused on the intended area of coverage. This will minimize HF reflections, lower the reverberant field in the room and give better intelligibility.

5

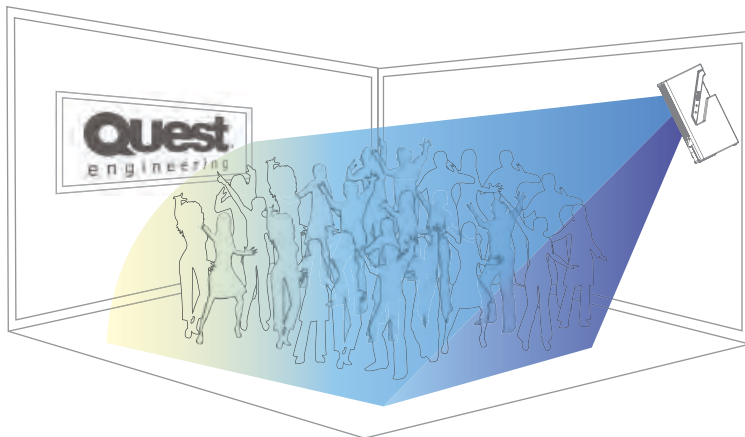

**Ideal HPI110 Flown Configuration**

## Flying the HPI110

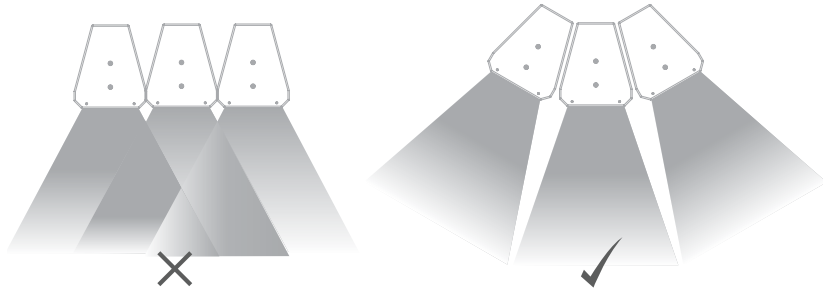

The HPI 110 can be flown in a permanent installation by attaching the designed flying hardware. The HPI-110 can be wall mounted or hung in a flown installation using the flying fitting accessory. For more information, see the Quest HPI flying hardware manual.

The HPI110 horizontal horn covers both “short-throw” and “long-throw” requirements in a single system. For the majority of installations (where the box is installed vertically), the asymmetrical horn should be used as supplied and cannot be rotated.

### When installing with the QR3/4 Flying system

The QR-3/4 array plates are designed to give the installer a range of horizontal pattern coverage options. For more information see the Quick Rig user manual. The HPI 110 also has a number of threaded M10 mounting points which can be utilised if a custom bracket is required.

**6** Before suspending any speaker system always inspect all components (enclosure, rigging frames, eyebolts, track fittings, etc.) for cracks, deformations, corrosion, missing, loose or damaged parts that could reduce strength and safety of the array. Do not suspend the speaker system until the correct preparation of the installation site has been taken to avoid health risks during and after the completion of the installation. A licensed Professional Engineer must approve the placement and method of attachment to the structure prior to the installation of any overhead object.

Good coverage of audiences often requires wide dispersion at the base of the horn flare to cover close listeners and a focused narrow dispersion at the top of the flare to beam to the back of the room.



## WARNING

Ensure the box is securely located. If any doubt about the physical stability, tie the box down with ratchet straps to a secure base.



**HPI 110 Wave Guide Examples**

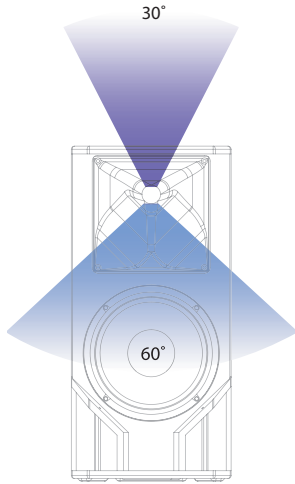

**HPI110 Vertical Front**

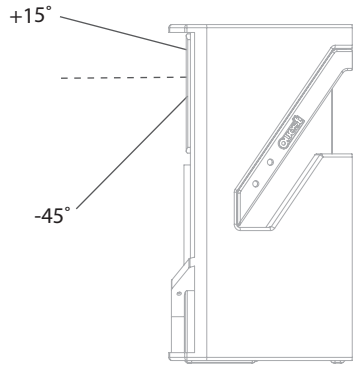

**HPI110 Vertical Side**

7

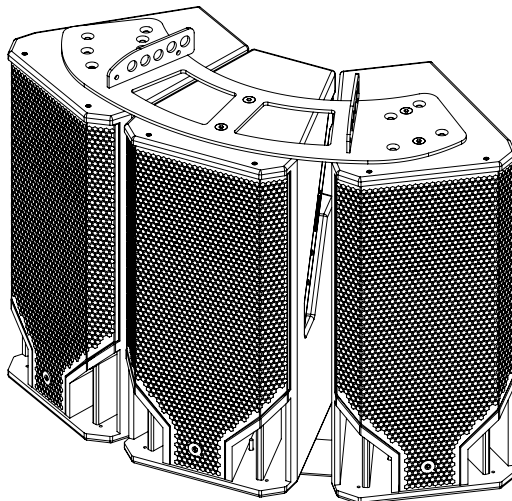

## HPI110 Specifications

### Typical Frequency Response

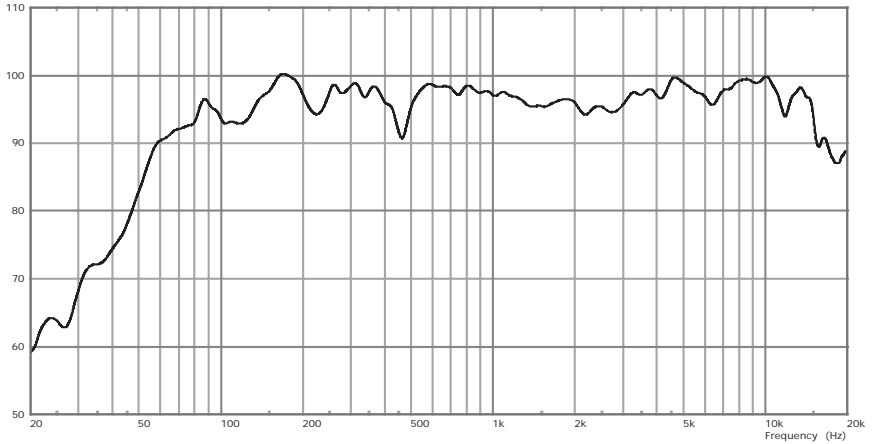

— HPI 110 - Frequency Response - 2.83V/1m

### Technical Specifications

Power Handling	300W AES 600W Continuous Program
Frequency Response	60-18kHz (+/-3dB)
Sensitivity	95.5dB @ 1kHz
Maximum SPL @ 1m	130dB
Impedance	8 ohms
Connections and Wiring	2 x Speakon NL4 - 1+/1- (2+/2- through)
Woofer	10" High Power Mid-Bass Woofer
Tweeter	3" Neo Compression Driver (1.4" Exit)
Directivity	Asymmetric +15/-45 Vertical; 30/60 Horizontal
Dimensions	620x380x346.5 mm
Weight	16.1kg Net

## HPI110 Reference Diagram

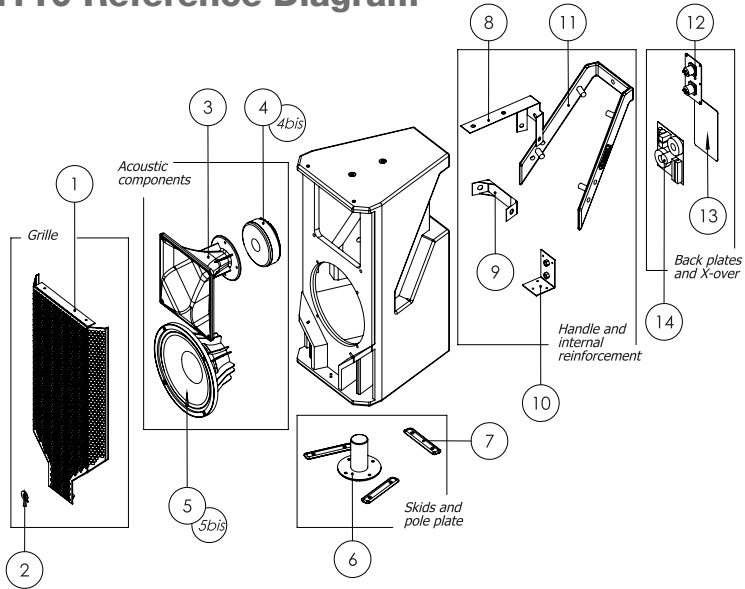

9

No.	Description	Spare Part
1	Complete grille (includes glued acoustic foam)	HGHPI110
2	Rotating Q-badge (25mm) with Spring Loaded Pin	HQB25
3	Asymmetric Horn Flare (GT12)	HWG110
4	1.4" Compression Driver	T2005
4bis	Compression Driver Recone (diaphragm)	RT2005
5	10" Woofer	T10003
5bis	10" Woofer Recone Kit	RT10003
6	Steel Pole Bottom Mount Plate	HPP110
7	Rubber skids (137mm)	HSK137
8	Internal Metal Brace - 1 (Top)	HIB110-1
9	Internal Metal Brace - 2 (Centre)	HIB110-2
10	Internal Metal Brace - 3 (Bottom)	HIB110-3
11	Aluminum HPI Handle	HAH110
12	Connection Plate	HCP110
13	Passive Filter Network for HPI110 (x-over)	AXHPI110
14	Manufacturer Plate for HPI110	HMP110

## Register Your Product

Thank you for choosing Quest. Please take the time to complete your product registration card which is included with the packaging.

Registering your Quest Engineering product will:

- CONFIRM YOUR WARRANTY
- REGISTER YOUR PRODUCT
- PROTECT YOUR NEW PRODUCT

**REGISTER ONLINE:**

[www.questengineering.com.au/registration](http://www.questengineering.com.au/registration)

**quest**<sup>™</sup>  
engineering

[www.questengineering.com.au](http://www.questengineering.com.au)