

Digital Mixers

X32 RACK

POWERED BY MIDAS

40-Input, 25-Bus Digital Rack Mixer with 16 Programmable MIDAS Preamps, FireWire*/USB Audio Interface and iPad/iPhone* Remote Control

- 40-input channel, 25-bus, 3U rack-mountable digital mixer for live and installed sound application
- 16 MIDAS-designed, fully programmable mic preamps for audiophile sound quality
- 8 XLR outputs plus 6 additional line in/outputs, 2 phones connectors and a talkback section with XLR mic input
- 32 x 32 channel USB 2.0 audio interface
- iPad* and iPhone* apps for professional remote operation available free of charge—no host PC required
- High-resolution 5" day-viewable Color TFT for easy viewing of workflow components and parameters
- Main LCR, 6 matrix buses and all 16 mix buses each featuring inserts, 6-band parametric EQ's and full dynamics processing, plus 8 DCA and 6 mute groups
- Virtual FX rack featuring 8 true-stereo FX slots include high-end simulations such as Lexicon 480L* and PCM70*, EMT250* and Quantec QRS* etc.
- 40-Bit floating-point DSP features "unlimited" dynamic range with no internal overload and near-zero overall latency (0.8 msec)
- Powerful scene management for convenient handling of complex productions
- 48-channel Digital Snake ready** via dual AES50 ports, featuring KLARK TEKNIK's SuperMAC networking capability for ultra-low jitter and latency



40-Input Channel, 25-Bus Digital Rack Mixer with 16 Programmable MIDAS Preamps, FireWire*/USB Audio Interface and iPad/iPhone* Remote Control

It can be your top-notch studio recording interface today, control a complex theatre production tomorrow, or sit securely in your side-rack while you're mixing your band's club gig from your iPad. The X32 RACK is a revolutionary new product genre that combines finest analog I/O and powerful digital connectivity, with ample processing for 40 channels, 25 buses and up to 152 signal sources.

While every parameter of your mix can be adjusted directly on the X32 RACK through its 800 x 480 graphic UI, networked remote control literally makes room for new possibilities. Several instances of our XControl PC/Mac application, XiControl app for iPad/iPad mini and XiQ app for iPhone/iPod touch allow controlling the mix from exactly the place you find most suitable.

16 MIDAS-design mic preamps provide plenty of inputs—and with its dual AES50 ports, X32 RACK can support up to six S16 digital snakes for massive I/O connectivity.

8 powerful stereo FX engines coupled with ultra-flexible routing options make the X32 RACK the ideal choice for handling audio now—and as your needs grow.





- USB type-A connector providing file storage and uncompressed stereo recordings plus show presets and system updates
- ULTRANET connectivity for BEHRINGER's P16 Personal Monitoring System**
- Networked remote control via Ethernet for show setups with on-screen software editor
- Built-in expansion port for audio interface cards or digital networking bridges
- MIDI In/Out for remote scene recall or controlling other MIDI equipment
- Future firmware updates, incl. new FX "Plug Ins", downloadable from behringer.com free of charge
- Conceived and designed by BEHRINGER Germany

Front Panel Controls

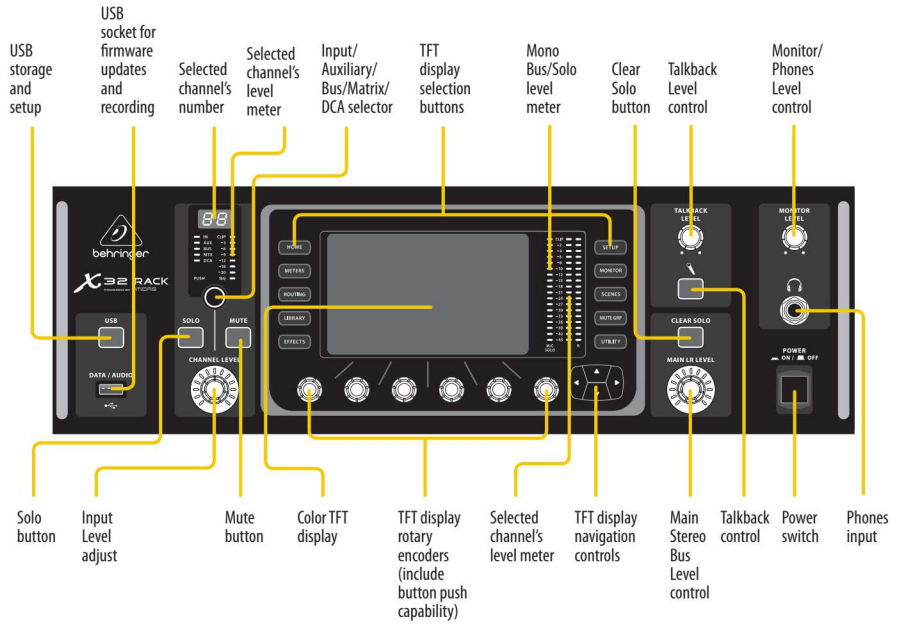

Rear Panel Input/Output Patchbay

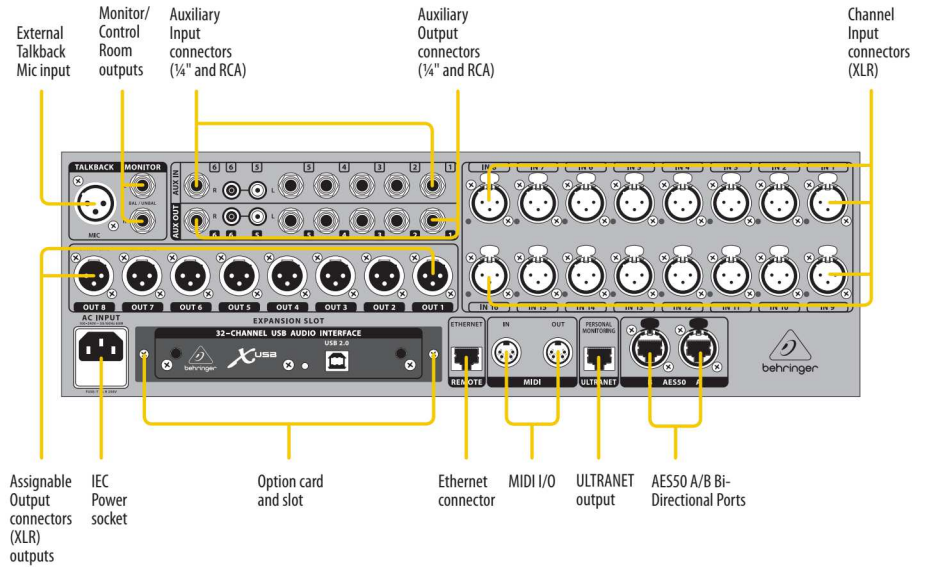

*iPad and iPhone are trademarks of Apple Inc. All third-party trademarks including but not limited to Lexicon, PCM, EMT, Quantec and QRS are trademarks or registered trademarks of their respective owners. Their use neither constitutes a claim of the trademarks by MUSIC Group nor affiliation of the trademark owners with MUSIC Group. Product names are mentioned solely as a reference for X32 RACK compatibility and effects.

**P16 Personal Monitoring System and Digital Snake are not included.



X32 RACK Live Performance Setup with S16 and P16 Monitor System

— Digital cable (CAT5)
— Analog Cable

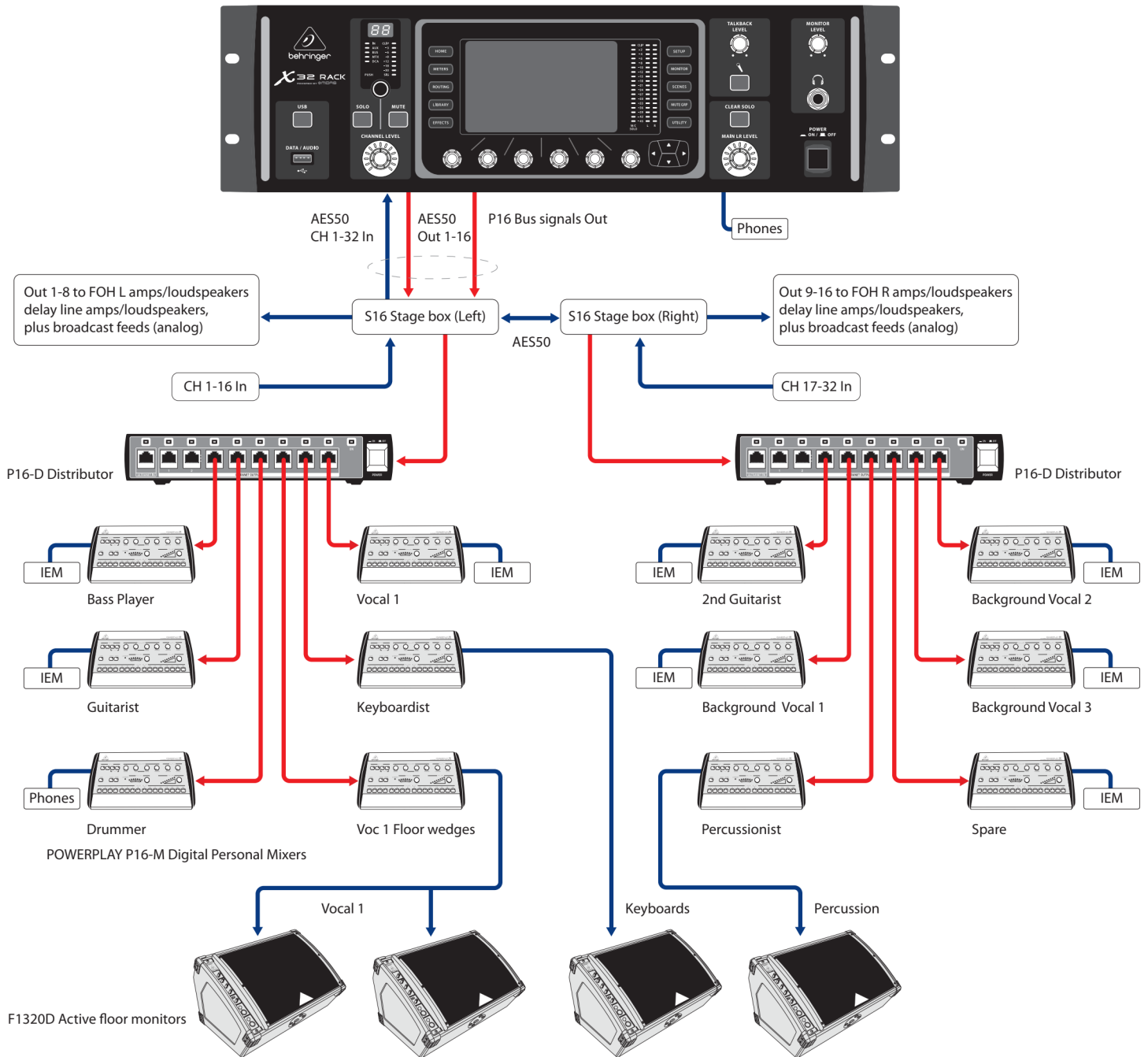



X32 RACK Recording Studio Setup

Control Room

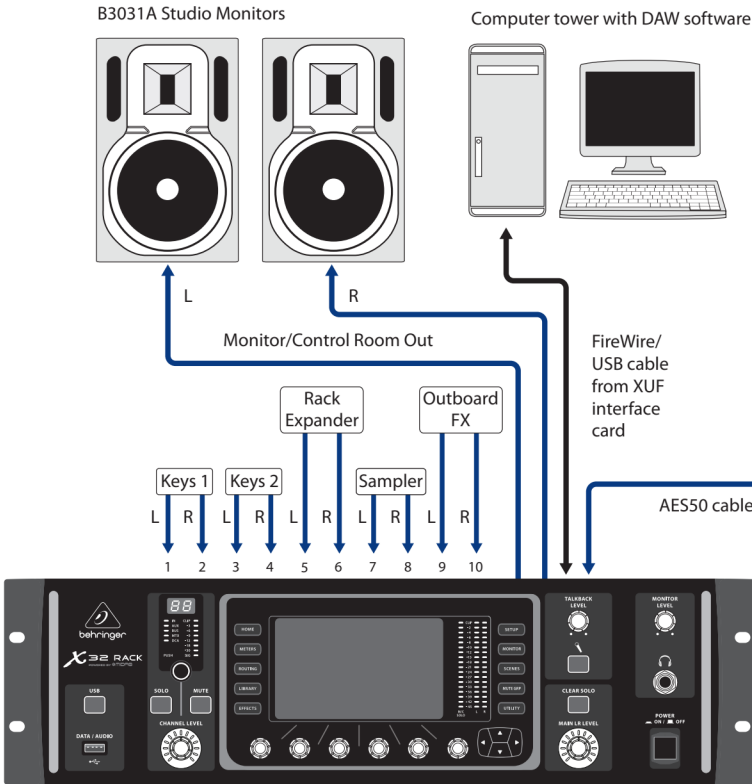

Recording Room

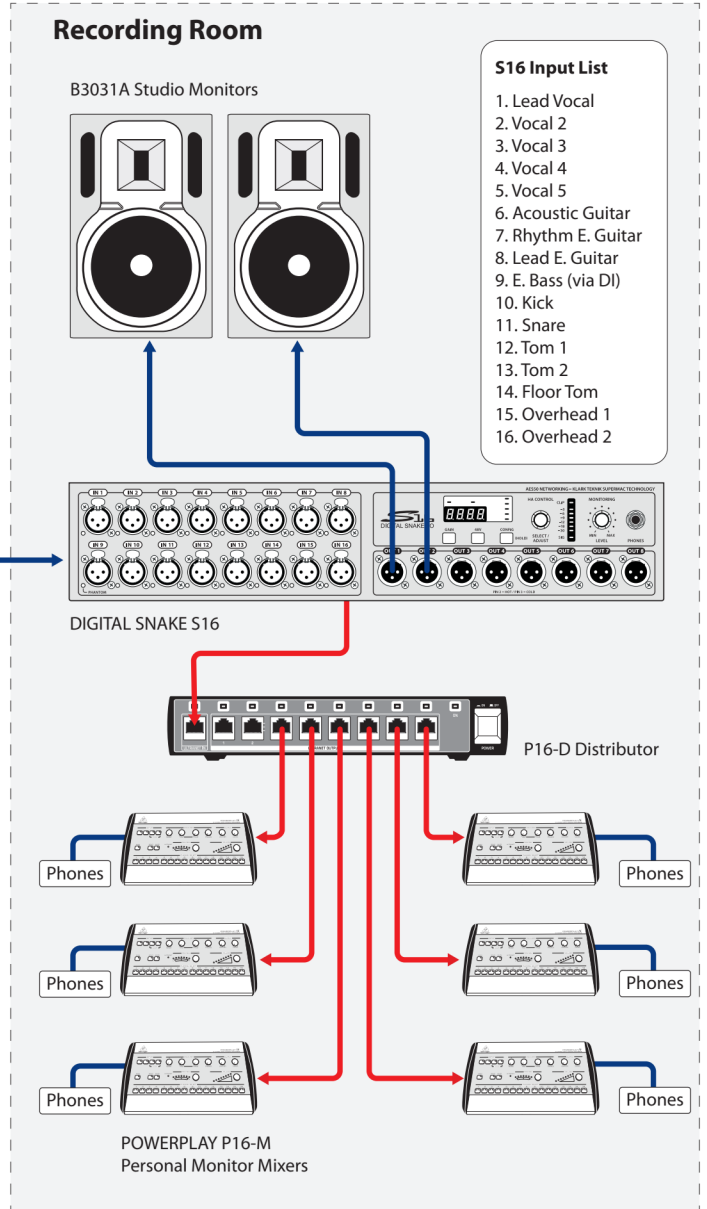



Specifications

Processing

Number of processing channels	32 input channels, 8 aux in channels, 8 FX return channels, 16 buses, 6 matrices, main LRC
Internal effects engines, true-stereo / mono	8 / 16
Internal total recall scenes (inkl. preamp and fader)	100
Signal processing	40-bit floating point
A/D-D/A conversion (Cirrus Logic A/D CS5368, D/A CS4385)	24-bit @ 44.1 / 48 kHz, 114 dB dynamic range
Local I/O latency (local in > console processing* > local out)	0.8 ms
Networked I/O latency (stagebox in > console processing* > stagebox out)	1.1 ms
Total number of accessible input sources / outputs	150 / 158

Connectors

XLR inputs, programmable mic preamps, designed by MIDAS	16
Talkback mic input, XLR	1 ext. (no internal mic)
RCA inputs/outputs	2/2
XLR outputs	8
Monitoring outputs, ¼" TRS balanced	2
Aux inputs/outputs, ¼" TRS, balanced	6/6
Phones outputs, ¼" TRS	1 stereo (in front panel)
Digital AES/EBU output, XLR	—
AES50 ports, SuperMAC	2
Expansion card (optional)	32 channel audio input/output, various standards
P-16 connector, Ultramet (no power supplied)	1
MIDI inputs / outputs	1 / 1
Ethernet, RJ45, rear panel, for remote control	1
USB Type A, top panel, for audio and data export/import	1

Mic Input Characteristics

Preamp Design	MIDAS
THD + noise, 20 dB gain, 0 dBu out	< 0.006% A-weighted
Input impedance XLR, unbal. / bal.	5 kΩ / 10 kΩ
Non clip maximum input level, XLR	+23 dBu
Phantom Power, switchable per input	48 V
Equivalent input noise level, XLR (input shorted)	-128 dBu
CMRR, XLR, @ 20 dB gain (typical)	> 70 dB
CMRR, XLR, @ 40 dB gain	> 80 dB

Input/Output Characteristics

Frequency range, @ 48 kHz sample rate, 0 dB to -1 dB	10 Hz - 22 kHz
Dynamic range, analog in to analog out (typical)	106 dB
A/D Dynamic range, preamp and converter (typical)	109 dB
D/A Dynamic range, converter and output	108 dB
Cross talk rejection @ 1 kHz, adjacent channels	100 dB
Output level, XLR, nom./max.	+4 dBu / +21 dBu
Output impedance, XLR, unbal. / bal.	75 Ω / 75 Ω
Input impedance TRS Jack, unbal. / bal.	20 kΩ / 40 kΩ
Non clip maximum input level, TRS	+16 dBu
Nominal output level, TRS	+4 dBu / +16 dBu
Output impedance, TRS, unbal. / bal.	150 Ω / 300 Ω
Phones output impedance / level	40 Ω / +25 dBm (stereo)
Residual noise level, XLR and TRS	-87 dBu A-weighted

Indicators

Main Screen	5", 800x480, 262k color TFT
Main Meter	-57 dB, -54dB, -51 dB, -48 dB, -45 dB, -42 dB, -39 dB, -36 dB, -33 dB, -30 dB, -27 dB, -24 dB, -21 dB, -18 dB, -15 dB, -12 dB, -10 dB, -8 dB, -6 dB, -4 dB, -3 dB, -2 dB, -1 dB, Clip
Rear Panel	—

Power

Switch-mode autorange power supply	100-240 V (50/60 Hz)
Power consumption	120 W

Physical

Dimensions	132 x 483 x 287 mm (5.2 x 19 x 11.3")
Weight	6.5 kg (14.4 lbs)

*incl. all channel and bus processing, excl. insert effects and line delays

Please note these specifications are preliminary and conceptual in nature, and as such are subject to change as product development progresses. This information is supplied for market research purposes only and is not to be made public in any manner. This document is solely the property of The MUSIC Group, or one of its subsidiaries, and must be surrendered upon request of the owner.

For service, support or more information contact the BEHRINGER location nearest you:

Europe
MUSIC Group Services UK
Tel: +44 156 273 2290
Email: CARE@music-group.com

USA/Canada
MUSIC Group Services NV Inc.
Tel: +1 702 800 8290
Email: CARE@music-group.com

Japan
MUSIC Group Services JP K.K.
Tel: +81 3 6231 0454
Email: CARE@music-group.com

Technical specifications and appearances are subject to change without notice and accuracy is not guaranteed. BEHRINGER, KLARK TEKNIK, MIDAS, BUGERA, and TURBOSOUND are part of the MUSIC Group (music-group.com). FireWire, Mac, iPod touch, iPhone, iPad, and iPad mini are trademarks of Apple Inc., registered in the U.S. and other countries. The AES50 trademark is a property of the Audio Engineering Society, NY. All trademarks, including, but not limited to Lexicon, PCM, EMT, Quantec and ORS are trademarks or registered trademarks of their respective owners. Their use neither constitutes a claim of the trademarks nor affiliation of the trademark owners with MUSIC Group. Product names are mentioned solely as a reference for X32 RACK compatibility and effects. MUSIC Group accepts no liability for any loss which may be suffered by any person who relies either wholly or in part upon any description, photograph or statement contained herein. Colors and specifications may vary from actual product. MUSIC Group products are sold through authorized fulfillers and resellers only. Fulfillers and resellers are not agents of MUSIC Group and have absolutely no authority to bind MUSIC Group by any express or implied undertaking or representation. This manual is copyrighted. No part of this manual may be reproduced or transmitted in any form or by any means, electronic or mechanical, including photocopying and recording of any kind, for any purpose, without the express written permission of MUSIC Group IP Ltd. ALL RIGHTS RESERVED © 2013 MUSIC Group IP Ltd. Trident Chambers, Wickhams Cay, P.O. Box 146, Road Town, Tortola, British Virgin Islands.

behringer.com

