

Symaro™

Duct Relative Humidity and Temperature Sensor Modbus RTU

QFM2150/MO



Duct relative humidity and temperature sensor with Modbus communication

- Modbus RTU (RS-485)
- Measuring accuracy 3 % r.h. within the comfort range
- On-event addressing via push button together with Climatix™ controllers
- DIP switches setting together with other controllers

Use

The duct sensor is used in air ducts of ventilation and air conditioning plant for acquiring:

- Relative humidity
- Temperature

The sensor is used as:

- Control sensor in the supply or exhaust air
- Reference sensors, for example, for shifting the dew point
- Limit sensors, for example, in connection with steam humidifiers
- Limit sensors, for example, for measured value indication or for connection to a building automation and control system

Technical design

Cable entry is made via the screwed cable gland M16 supplied with the sensor.

The sensor is fitted with the mounting flange supplied with the sensor. The flange is placed over the immersion rod and then secured to meet the required immersion length.

Type summary

Product number	SSN NO.	Temperature measuring range	Operating voltage	Output signal
QFM2150/MO	S55720-S467	-40...70 °C	AC 24 V ±20 %/ DC 13.5...35 V	Modbus RTU

Ordering and delivery

When ordering, specify name and product number, for example: Duct sensor QFM2150/MO.

Accessory

Name	Type reference
Filter cap (for replacement)	AQF3101

Notes

Engineering

Powering the sensor requires a transformer for safety extra low-voltage (SELV) with separate windings for 100 % duty. When sizing and protecting the transformer, comply with all local safety regulations.

When sizing the transformer, determine the power consumption of the room sensor.

For correct wiring, see the datasheets of the devices with which the sensor is used.

Observe permissible line lengths.

Cable routing and cable selection

Note that when routing cables, the longer the cables run side by side and the smaller the distance between them, the greater the electrical interference. Shielded cables must be used in environments with EMC problems.

Twisted pair cables are required for the secondary supply lines and the signal lines.

Mounting

Location

Mount the sensor in the center of the duct wall. If used together with steam humidifiers, the minimum distance from the humidifier must be 3 m to maximum 10 m.

Fit the sensor in the exhaust air duct if the application involves dew point shifting.

Fit the flange to the duct wall. Then, insert the sensor through the flange and fasten.

- To ensure degree of protection IP54, the sensor must be mounted with the cable entry pointing downward.
- The sensing elements inside the measuring tip are sensitive to impact. Avoid any impact on mounting.

Mounting instructions

Mounting instructions are enclosed in the package.

NOTICE!

Chemical vapors

A humidity sensor is a sensitive measurement device and must be handled with great care.

Chemical vapors at high concentration in combination with long exposure time may offset the sensor reading.

Disposal



This symbol or any other national label indicate that the product, its packaging, and, where applicable, any batteries may not be disposed of as domestic waste. Delete all personal data and dispose of the item(s) at separate collection and recycling facilities in accordance with local and national legislation.

For additional details, refer to www.siemens.com/bt/disposal.

Function	
Communication	Modbus RTU (RS-485)
Supported baud rate	9600; 19200; 38400; 57600; 76800; 115200
Transmission format	1-8-E-1; 1-8-O-1; 1-8-N-1; 1-8-N-2
Bus termination	120 ohm, jumper selection

For detailed information about specific functions, see Basic documentation (A6V11610643 *).

Power supply	
Operating voltage	AC 24 V ± 20 % or DC 13.5...35 V (SELV) or AC/DC 24 V class 2 (US)
Frequency	50/60 Hz at AC 24 V
External supply line protection	Fuse slow max. 10 A or Circuit breaker max. 13 A Characteristic B, C, D according to EN 60898 or Power source with current limitation of max. 10 A
Power consumption	≤ 1.5 VA

Functional data	
Humidity sensor	
Range of use	0...95 % r.h. (non-condensing)
Measuring range	0...100 % r.h.
Measuring accuracy at 23 °C and AC/DC 24 V in 0...95 % r.h. 30...70 % r.h.	± 5 % r.h. ± 3 % r.h. (typical)
Time constant at 0...50 °C and 10...80 % r.h.	< 20 s
Perm. air velocity	20 m/s
Temperature sensor	
Measuring range	-40...70 °C
Measuring accuracy at AC/DC 24 V in 23 °C 15...35 °C -35...50 °C	± 0.3 K ± 0.6 K ± 1 K
Time constant	< 3.5 min in 2 m/s moved air

Ambient conditions and protection classification	
Protection degree of housing	IP54 according to EN 60529 in built-in state
Protection class	III according to EN 60730-1
Environmental conditions Transport <ul style="list-style-type: none"> • Climatic conditions <ul style="list-style-type: none"> – Temperature – Humidity • Mechanical conditions Operation <ul style="list-style-type: none"> • Climatic conditions <ul style="list-style-type: none"> – Temperature (housing with electronics) – Humidity • Mechanical conditions 	IEC 60721-3-2 Class 2K3 -25...70 °C < 95 % r.h. Class 2M2 IEC 60721-3-3 Class 3K5 -15...60 °C 0...95 % r.h. (non-condensing) Class 3M2

Standards, directives and approvals	
Product standard	EN 60730-1, EN 60730-2-9, EN 61000-6-2, EN 61000-6-3 Automatic electrical controls for household and similar use
Electromagnetic compatibility (Applications)	For use in residential, commerce, light-industrial and industrial environments
EU conformity (CE)	A5W00037931A *)
RCM conformity	A5W00037932A *)
UL	UL 873, http://ul.com/database
UKCA	A5W00188743A *)
Environmental compatibility	The product environmental declaration (A5W90011832 *) contains data on environmentally compatible product design and assessments (RoHS compliance, materials composition, packaging, environmental benefit, disposal).

General	
Cable lengths for measuring signals Permissible cable lengths	See data sheet of the device handling the signal
Electrical connections terminals	1 × 2.5 mm ² or 2 × 1.5 mm ²
Cable entry gland (enclosed)	M 16 × 1.5
Materials and colors	
Base	Polycarbonate, RAL 7001 (silver-grey)
Cover	Polycarbonate, RAL 7035 (light-grey)
Immersion rod	Polycarbonate, RAL 7001 (silver-grey)
Filter cap	Polycarbonate, RAL 7001 (silver-grey)
Mounting flange	PA 66 – GF35 (black)
Cable entry gland	PA, RAL 7035 (light-grey)

General	
Sensor (complete assembly)	Silicone-free
Packaging	Corrugated cardboard
Weight including package	Approx. 210.8 g

*) The documents can be downloaded from <http://siemens.com/bt/download>.

Connection terminals

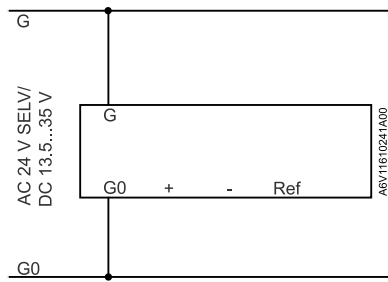

G	Operating voltage AC 24 V ± 20 % or DC 13.5...35 V
G0	Ground
+	RS485 Modbus A
-	RS485 Modbus B
Ref	GND_ISO

Dimensions

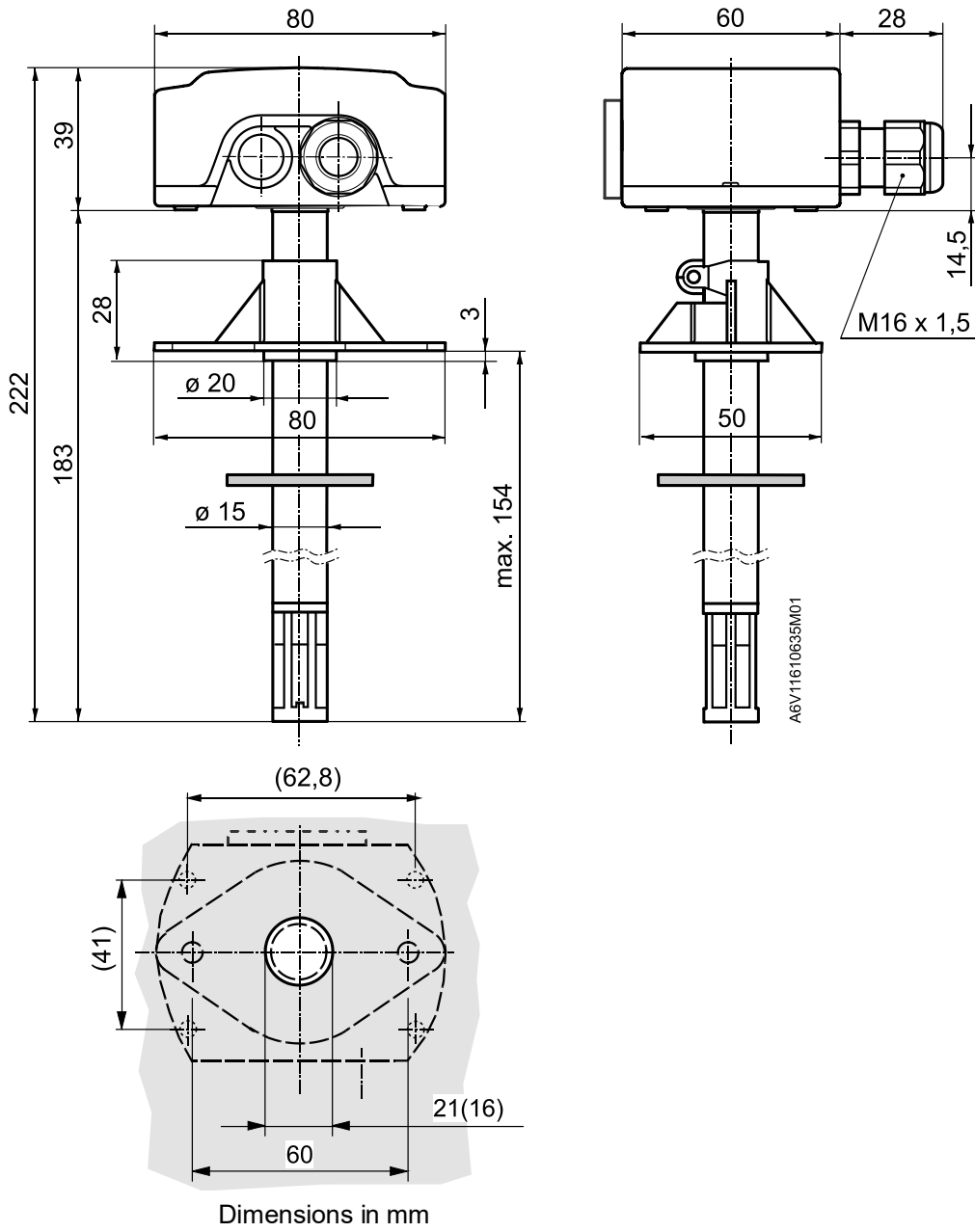

Issued by
Siemens Switzerland Ltd
Smart Infrastructure
Global Headquarters
Theilerstrasse 1a
CH-6300 Zug
+41 58 724 2424
www.siemens.com/buildingtechnologies

© Siemens Switzerland Ltd, 2019
Technical specifications and availability subject to change without notice.

Document ID A6V11610635_en--_b
Edition 2022-09-27