

Definition	Data	
Model	EM730-030-3B	
Application motor size kW (HP)	30 kW (40)	
Motor type	Asynchronous motor / Permanent magnet motor	
Overload capability	Heavy-duty rated current	150% of rate current 60 seconds 180% of rate current 10 seconds 200% of rate current 2 seconds
	Light-duty rated current	120% of rate current 60 seconds 150% of rate current 10 seconds 180% of rate current 2 seconds
Starting torque	150%/1Hz (VVF) , 150%/0.25Hz (SVC)	
Rated input voltage (V)	3 phase : 340V (-10%) ~ 460V (+10%)	
Rated output voltage (V)	0 ~ input voltage	
Rated output current (A)	Heavy-duty 60 A / Light-duty 70 A	
Output frequency (Hz)	0.00 ~ 600.00Hz / 0.0 ~ 3,000.0HZ	
Protective housing	IP20	
Cooling	FAN	
Minimum value of resistor (Ω)	10 Ω	
Carrier frequency	1 to 8 kHz	
Dimension (mm.)	W 245 x W1 200 x H 454 x H1 440 x D 205 x D2 212	

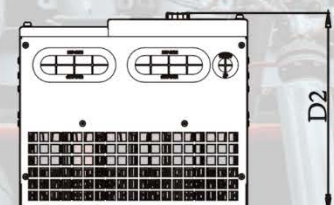

DIMENSION

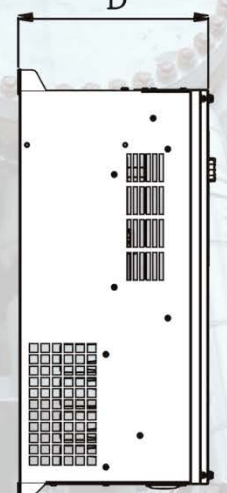
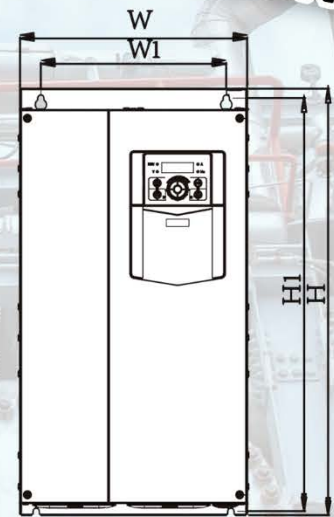

WIRING

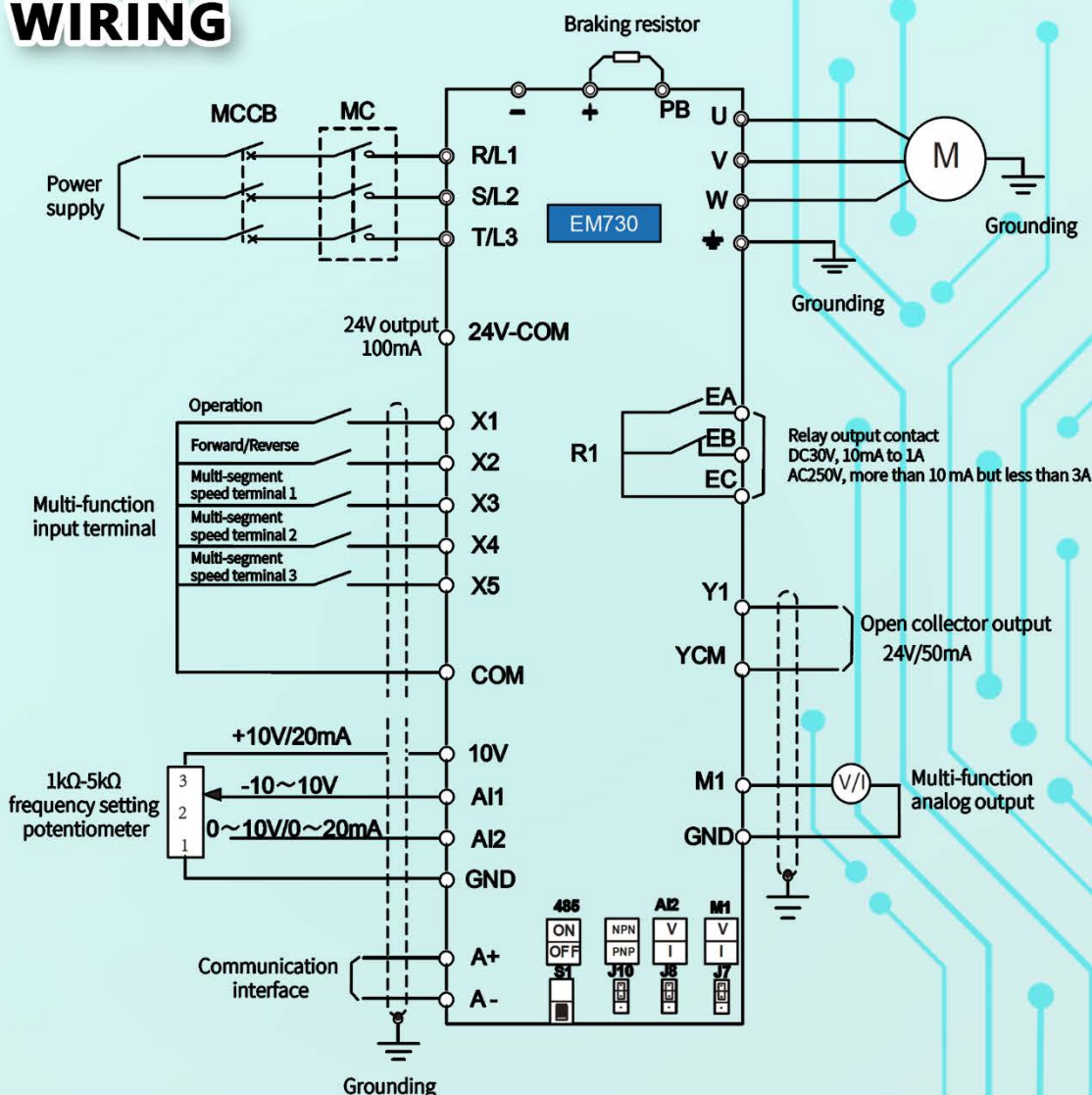

บริษัท ซีเอส ออโตเมชั่น ซิสเต็ม จำกัด

41 ซอยเอกชัย 97 ถนนกาญจนาภิเษก แขวงบางบอนใต้ เขตบางบอน กรุงเทพฯ 10150