

Definition	Data	
Model	EM730-011-3B	
Application motor size kW (HP)	11 kW (15)	
Motor type	Asynchronous motor / Permanent magnet motor	
Overload capability	Heavy-duty rated current	150% of rate current 60 seconds 180% of rate current 10 seconds 200% of rate current 2 seconds
	Light-duty rated current	120% of rate current 60 seconds 150% of rate current 10 seconds 180% of rate current 2 seconds
Starting torque	150%/1Hz (VVF) , 150%/0.25Hz (SVC)	
Rated input voltage (V)	3 phase : 340V (-10%) ~ 460V (+10%)	
Rated input current (A)	32 A	
Rated output voltage (V)	0 ~ input voltage	
Rated output current (A)	Heavy-duty 25 A / Light-duty 28 A	
Output frequency (Hz)	0.00 ~ 600.00Hz / 0.0 ~ 3,000.0Hz	
Protective housing	IP20	
Cooling	FAN	
Minimum value of resistor (Ω)	30 Ω	
Carrier frequency	1 to 8 kHz	
Dimension (mm.)	<u>W</u> 136 x <u>W1</u> 125 x <u>H</u> 250 x <u>H1</u> 240 x <u>D</u> 169 x <u>D2</u> 174	
Weight	4.66 kg	

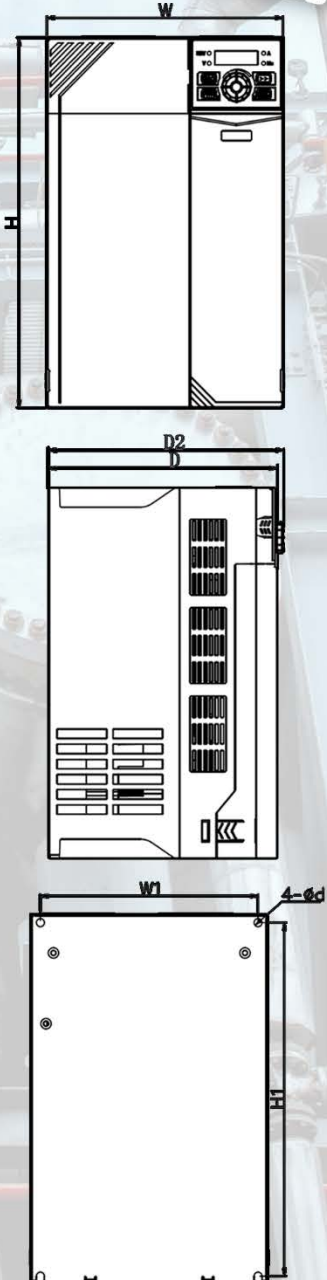

DIMENSION



WIRING

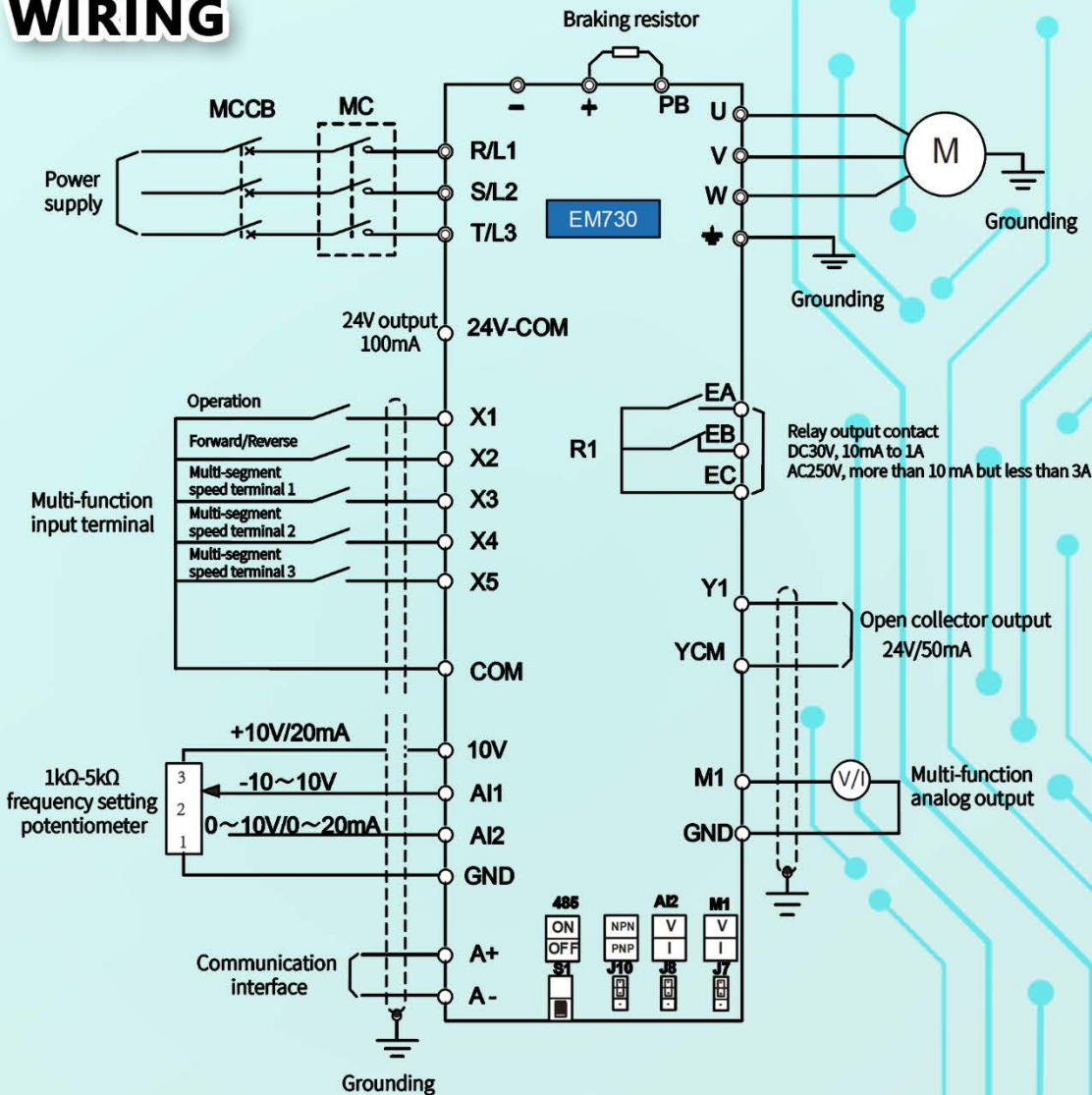

บริษัท ซีเอส ออโตเมชั่น ซิสเต็ม จำกัด

41 ซอยเอกชัย 97 ถนนกาญจนาภิเษก แขวงบางบอนใต้ เขตบางบอน กรุงเทพฯ 10150