

OPTIMUM

V BELT PULLEY



 038-016999

 SALES9@MOTION.CO.TH / SALES10@MOTION.CO.TH
MOTION POWER AND SERVICES CO., LTD

CONTENTS

TAPER BUSHING V-BELT PULLEYS

P.M SPZ	3~13
P.M SPA	14~24
P.M SPB	25~37
P.M SPC	38~48

PILOT BORED V-BELT PULLEYS

P.M SPZ	49~51
P.M SPA	52~60
P.M SPB	61~69
P.M SPC	70~75

The logo for OPTIMUM, featuring the word "OPTIMUM" in a bold, italicized, white sans-serif font, centered within a solid red rectangular background.

V-belt pulleys are devices which transmit power between axles by the use of a v-belt, a mechanical linkage with a trapezoidal cross-section. Together these devices offer a high-speed power transmission solution that is resistant to slipping and misalignment.

The most notable difference between a v-belt pulley and other types of pulleys (round belt, flat, etc.) would be the geometry of the groove or grooves located around the circumference of the pulley; these grooves guide and gain traction on a v-belt.

We have available an extensive range of pulleys to suit all cross sections of V-Belts . with a pilot bore, bored & keyed or with a taper lock bush arrangement.



PULLEY dimensions

PART NO.	a	b	c	d	e	f	h	α°	
								34°	38°
SPZ[mm]	9.7	8.5	8	12	8	2	11	P ≤ 80	P > 80
SPA[mm]	12.7	11	10	15	10	2,8	13.8	P ≤ 118	P > 118
SPB[mm]	16.3	14	12.5	19	12,5	3,5	17.5	P ≤ 190	P > 190
SPC[mm]	22	19	17	25.5	17	4,8	23.8	P ≤ 315	P > 315

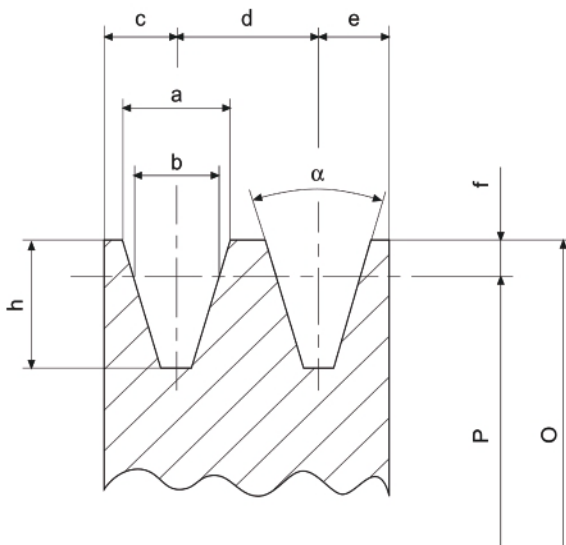

Calculation of peripheral speed Vp in m/s

$$V_p = \frac{\pi \cdot P \cdot \text{rpm}}{60 \cdot 1000} \cong \frac{P \cdot \text{rpm}}{19100} \quad V_p \leq 35 \text{ m/s}$$

P = pitch diameter in mm
rpm = Revolutions per minute

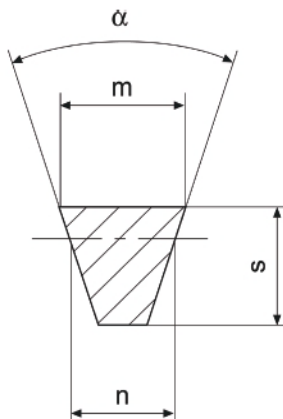

Belt dimensions

PART NO.	m	s	n	α°	
				34°	38°
SPZ[mm]	9.7	8	8.5	P ≤ 80	P > 80
SPA[mm]	12.7	10	11	P ≤ 118	P > 118
SPB[mm]	16	13	14	P ≤ 190	P > 190
SPC[mm]	22	18	19	P ≤ 315	P > 315

P.M SPZ/01

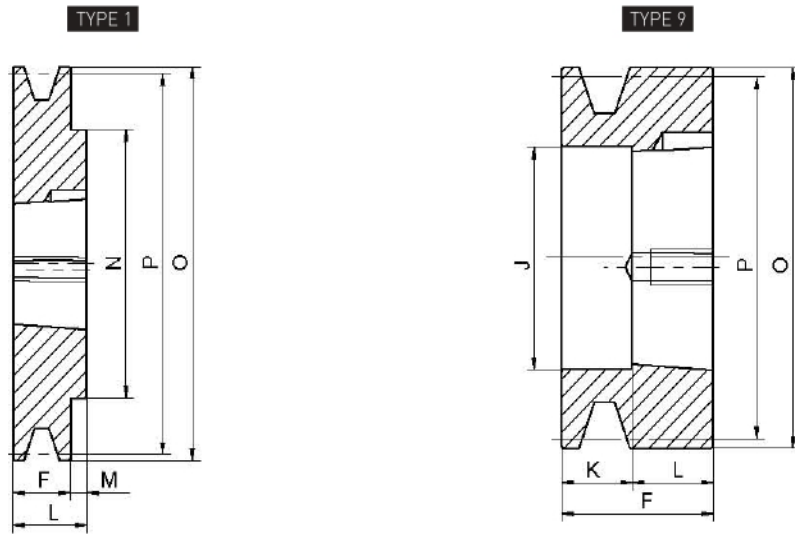

P.M SPZ/01

Product Model	Grooves	P	O	TYPE	BUSH	MAX Bore	E	F	J	K	L	M	N	Weight (Kg)
*SPZ50-01	11	50	54	99	1008	25	---	37	26	12	25	---	---	0.350.
*SPZ56-01	11	56	60	11	1008	25	---	37	32	12	25	---	-56	480.
*SPZ60-01	11	60	64	11	1008	25	---	22	---	---	22	6	60	300.
SPZ63-01	11	63	67	11	1108	28	---	16	---	---	22	6	60	230.
SPZ67-01	11	67	71	11	1108	28	---	16	---	---	22	6	60	300.
SPZ69-01	11	69	73	11	1108	28	---	16	---	---	22	6	60	330.
SPZ71-01	11	71	75	11	1108	28	---	16	---	---	22	6	60	350.
SPZ73-01	11	73	77	11	1108	28	---	16	---	---	22	6	60	380.
SPZ75-01	11	75	79	11	1108	28	---	16	---	---	22	6	75	400.
SPZ78-01	11	78	82	11	1108	28	---	16	---	---	22	9	75	450.
SPZ80-01	11	80	84	11	1210	32	---	16	---	---	25	9	80	490.
SPZ83-01	11	83	87	11	1210	32	---	16	---	---	25	9	80	550.
SPZ85-01	11	85	89	11	1210	32	---	16	---	---	25	9	80	600.
SPZ88-01	11	88	92	11	1210	32	---	16	---	---	25	9	85	650.
SPZ90-01	11	90	94	11	1210	32	---	16	---	---	25	9	85	700.
SPZ93-01	1	93	97	1	1210	32	-	16	---	---	25	9	85	760.
SPZ95-01		95	99		1210	32		16			25	9	85	800.
SPZ98-01		98	10210		1210	32		16			25	9	85	850.
SPZ100-01		10010	41071		1210	32		16			25	9	92	900.
SPZ103-01		31061	10113		1210	32		16			25	9	92	910.
SPZ106-01		09112	11611		1610	42		16			25	9	92	920.
SPZ109-01		11511	91221		1610	42		16			25	9	92	991.
SPZ112-01		81221	26129		1610	42		16			25	9	92	031.
SPZ115-01		25129	13313		1610	42		16			25	9	92	101.
SPZ118-01		13214	61441		1610	42		16			25	9	92	161.
SPZ122-01		0145	49		1610	42		16			25	9	92	241.
SPZ125-01					1610	42		16			25	9	92	301.
SPZ129-01					1610	42		16			25	9	92	411.
SPZ132-01					1610	42		16			25	9	92	451.
SPZ140-01					1610	42		16			25	9		651.
SPZ145-01					1610	42		16			25			78

* * * : Material steel

P.M SPZ/01

P.M SPZ(P. -P.13)
3

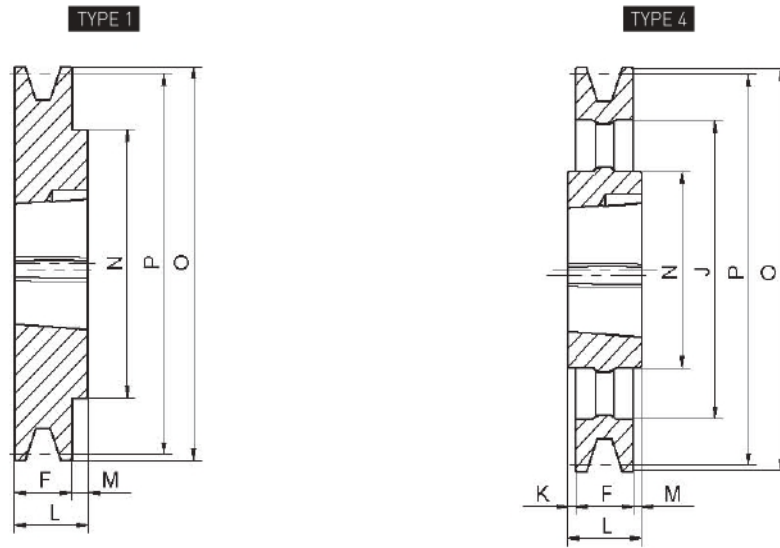

P.M SPZ/01

Product Model	Grooves	P	O	TYPE	BUSH	MAX Bore	E	F	J	K	L	M	N	Weight (Kg)
SPZ150-01	1	150	154	1	1610	42	—	16	—	—	25	9	92	1.92
SPZ160-01	1	160	164	1	1610	42	—	16	—	—	25	9	92	2.17
SPZ170-01	1	170	174	1	1610	42	—	16	—	—	25	9	92	2.45
SPZ180-01	1	180	184	4	1610	42	—	16	152	—	25	9	92	1.90
SPZ190-01	1	190	194	4	1610	42	—	16	162	—	25	9	92	2.00
SPZ200-01	1	200	204	4	2012	50	—	16	171	—	32	16	112	2.25
SPZ212-01	1	212	216	4	2012	50	—	16	183	—	32	16	112	2.75
SPZ224-01	1	224	228	4	2012	50	—	16	195	—	32	16	112	2.93
SPZ236-01	1	236	240	4	2012	50	—	16	207	8	32	8	112	3.11
SPZ250-01	1	250	254	4	2012	50	—	16	221	8	32	8	112	3.37
SPZ265-01	1	265	269	4	2012	50	—	16	236	8	32	8	112	3.41
SPZ280-01	1	280	284	4	2012	50	—	16	251	8	32	8	112	3.70
SPZ300-01	1	300	304	4	2012	50	—	16	271	8	32	8	112	4.20
SPZ315-01	1	315	319	4	2012	50	—	16	286	8	32	8	112	4.32
SPZ335-01	1	335	339	4	2012	50	—	16	306	8	32	8	112	4.55
SPZ355-01	1	355	359	4	2012	50	—	16	326	8	32	8	112	5.10
SPZ375-01	1	375	379	4	2012	50	—	16	346	8	32	8	112	5.52
SPZ400-01	1	400	404	4	2012	50	—	16	371	8	32	8	112	5.99
SPZ450-01	1	450	454	4	2517	60	—	16	421	14.5	45	14.5	124	7.19
SPZ500-01	1	500	504	4	2517	60	—	16	471	14.5	45	14.5	124	8.50

P.M SPZ/02

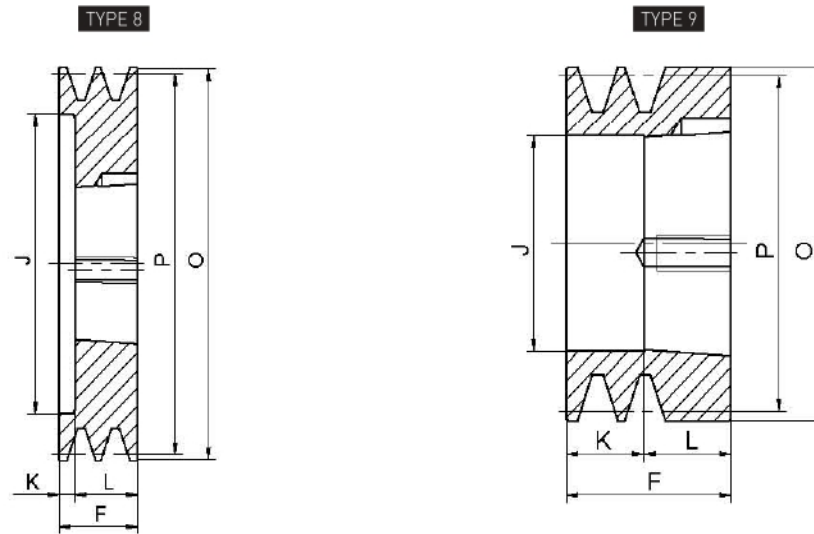

P.M SPZ/02

Product Model	Grooves	P	O	TYPE	BUSH	MAX Bore	E	F	J	K	L	M	N	Weight (Kg)
SPZ50-02	2	50	54	9	1008	25	—	50	26	25	25	—	—	0.46
SPZ56-02	2	56	60	9	1008	25	—	49	32	27	22	—	—	0.56
SPZ60-02	2	60	64	9	1108	28	—	49	36	27	22	—	—	0.60
SPZ62-02	2	62	66	9	1108	28	—	49	36	27	22	—	—	0.66
SPZ63-02	2	63	67	8	1108	28	—	28	40	6	22	—	—	0.30
SPZ65-02	2	65	69	8	1108	28	—	28	40	6	22	—	—	0.32
SPZ67-02	2	67	71	8	1108	28	—	28	42	6	22	—	—	0.36
SPZ69-02	2	69	73	8	1108	28	—	28	42	6	22	—	—	0.40
SPZ71-02	2	71	75	8	1108	28	—	28	42	6	22	—	—	0.45
SPZ73-02	2	73	77	8	1108	28	—	28	45	6	22	—	—	0.48
SPZ75-02	2	75	79	8	1210	32	—	28	51	3	25	—	—	0.41
SPZ76-02	2	76	80	8	1210	32	—	28	51	3	25	—	—	0.42
SPZ78-02	2	78	82	8	1210	32	—	28	51	3	25	—	—	0.45
SPZ80-02	2	80	84	8	1210	32	—	28	51	3	25	—	—	0.52
SPZ83-02	2	83	87	8	1210	32	—	28	58	3	25	—	—	0.60
SPZ85-02	2	85	89	8	1610	42	—	28	60	3	25	—	—	0.50
SPZ88-02	2	88	92	8	1610	42	—	28	61	3	25	—	—	0.58
SPZ90-02	2	90	94	8	1610	42	—	28	61	3	25	—	—	0.63
SPZ93-02	2	93	97	8	1610	42	—	28	64	3	25	—	—	0.70
SPZ95-02	2	95	99	8	1610	42	—	28	66	3	25	—	—	0.74
SPZ98-02	2	98	102	8	1610	42	—	28	69	3	25	—	—	0.85
SPZ100-02	2	100	104	8	1610	42	—	28	71	3	25	—	—	0.90
SPZ103-02	2	103	107	8	1610	42	—	28	74	3	25	—	—	0.95
SPZ106-02	2	106	110	8	1610	42	—	28	76	3	25	—	—	1.05
SPZ109-02	2	109	113	8	1610	42	—	28	80	3	25	—	—	1.15
SPZ112-02	2	112	116	8	1610	42	—	28	83	3	25	—	—	1.25
SPZ115-02	2	115	119	8	1610	42	—	28	86	3	25	—	—	1.30
SPZ118-02	2	118	122	8	1610	42	—	28	90	3	25	—	—	1.45
SPZ122-02	2	122	126	8	1610	42	—	28	93	3	25	—	—	1.57
SPZ125-02	2	125	129	8	1610	42	—	28	96	3	25	—	—	1.65
SPZ129-02	2	129	133	8	1610	42	—	28	100	3	25	—	—	1.75

* * * : Material steel

P.M SPZ/02 P.M SPZ(P. -P.13) 3

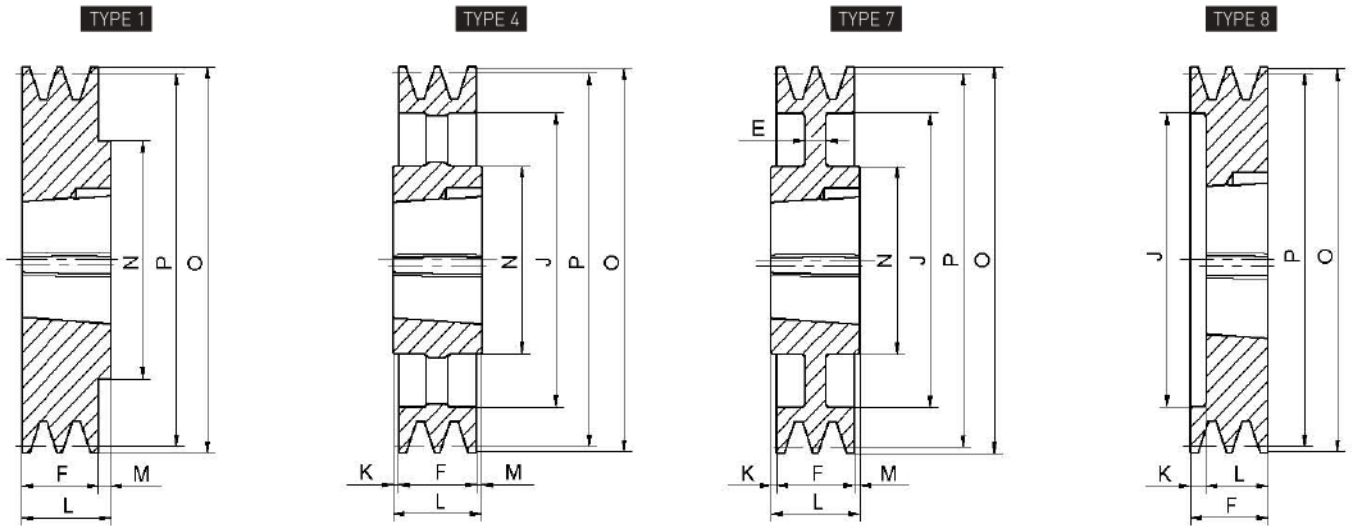

P.M SPZ/02

Product Model	Grooves	P	O	TYPE	BUSH	MAX Bore	E	F	J	K	L	M	N	Weight (Kg)
SPZ132-02	2	132	136	8	1610	42	—	28	103	3	25	—	—	1.90
SPZ136-02	2	136	140	8	1610	42	—	28	107	3	25	—	—	2.05
SPZ140-02	2	140	144	8	1610	42	—	28	111	3	25	—	—	2.22
SPZ145-02	2	145	149	1	2012	50	—	28	—	—	32	4	112	2.51
SPZ150-02	2	150	154	1	2012	50	—	28	—	—	32	4	112	2.74
SPZ155-02	2	155	159	1	2012	50	—	28	—	—	32	4	112	2.99
SPZ160-02	2	160	164	1	2012	50	—	28	—	—	32	4	112	3.23
SPZ165-02	2	165	169	1	2012	50	—	28	—	—	32	4	112	3.45
SPZ170-02	2	170	174	1	2012	50	—	28	—	—	32	4	112	3.82
SPZ175-02	2	175	179	1	2012	50	—	28	—	—	32	4	112	3.95
SPZ176-02	2	176	180	1	2012	50	—	28	—	—	32	4	112	4.04
SPZ180-02	2	180	184	7	2012	50	10	28	152	—	32	4	112	3.18
SPZ185-02	2	185	189	7	2012	50	10	28	157	—	32	4	112	3.35
SPZ190-02	2	190	194	7	2012	50	10	28	162	—	32	4	112	3.45
SPZ195-02	2	195	199	7	2012	50	10	28	167	—	32	4	112	3.64
SPZ200-02	2	200	204	4	2012	50	—	28	171	—	32	4	112	4.20
SPZ212-02	2	212	216	4	2012	50	—	28	183	—	32	4	112	4.32
SPZ224-02	2	224	228	4	2012	50	—	28	195	—	32	4	112	3.86
SPZ236-02	2	236	240	4	2012	50	—	28	207	—	32	4	112	4.05
SPZ250-02	2	250	254	4	2012	50	—	28	221	2	32	2	112	4.22
SPZ265-02	2	265	269	4	2012	50	—	28	236	2	32	2	112	4.52
SPZ280-02	2	280	284	4	2012	50	—	28	251	2	32	2	112	4.85
SPZ300-02	2	300	304	4	2012	50	—	28	271	2	32	2	112	5.37
SPZ315-02	2	315	319	4	2012	50	—	28	286	2	32	2	112	5.49
SPZ335-02	2	335	339	4	2012	50	—	28	306	2	32	2	112	6.03
SPZ355-02	2	355	359	4	2012	50	—	28	326	2	32	2	112	6.19
SPZ375-02	2	375	379	4	2012	50	—	28	346	2	32	2	112	7.08
SPZ400-02	2	400	404	4	2517	60	—	28	371	8.5	45	8.5	124	8.95
SPZ450-02	2	450	454	4	2517	60	—	28	421	8.5	45	8.5	124	9.90
SPZ500-02	2	500	504	4	2517	60	—	28	471	8.5	45	8.5	124	10.25
SPZ630-02	2	630	634	4	3020	75	—	28	601	11.5	51	11.5	146	15.60

P.M SPZ/03

TAPER BUSHING V-BELT PULLEYS

- P.M SPZ/02
- P.M SPZ/03

TAPER BUSHING V-BELT PULLEYS

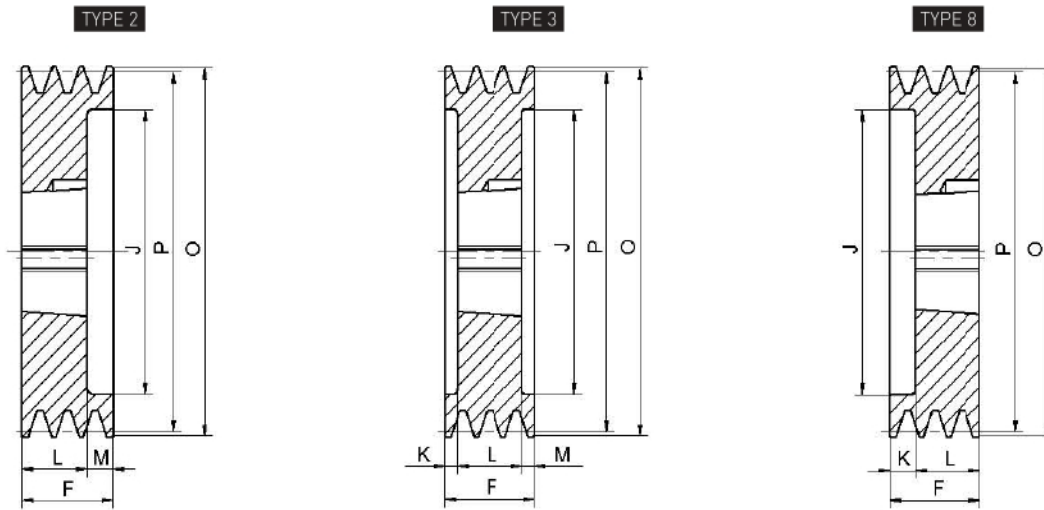

P.M SPZ/03

Product Model	Grooves	P	O	TYPE	BUSH	MAX Bore	E	F	J	K	L	M	N	Weight (Kg)
SPZ63-03	3	63	67	8	1108	28	—	40	40	18	22	—	—	0.41
SPZ67-03	3	67	71	8	1108	28	—	40	42	18	22	—	—	0.50
SPZ71-03	3	71	75	8	1108	28	—	40	42	18	22	—	—	0.53
SPZ75-03	3	75	79	8	1210	32	—	40	51	15	25	—	—	0.56
SPZ80-03	3	80	84	8	1210	32	—	40	51	15	25	—	—	0.70
SPZ83-03	3	83	87	8	1210	32	—	40	54	15	25	—	—	0.79
SPZ85-03	3	85	89	8	1610	42	—	40	60	15	25	—	—	0.65
SPZ90-03	3	90	94	8	1610	42	—	40	61	15	25	—	—	0.84
SPZ93-03	3	93	97	8	1610	42	—	40	64	15	25	—	—	0.95
SPZ95-03	3	95	99	8	1610	42	—	40	66	15	25	—	—	0.99
SPZ98-03	3	98	102	8	1610	42	—	40	69	15	25	—	—	1.09
SPZ100-03	3	100	104	8	1610	42	—	40	71	15	25	—	—	1.12
SPZ106-03	3	106	110	8	1610	42	—	40	76	15	25	—	—	1.35
SPZ109-03	3	109	113	8	1610	42	—	40	80	15	25	—	—	1.40
SPZ112-03	3	112	116	8	2012	50	—	40	83	8	32	—	—	1.37
SPZ115-03	3	115	119	8	2012	50	—	40	86	8	32	—	—	1.53
SPZ118-03	3	118	122	8	2012	50	—	40	90	8	32	—	—	1.65
SPZ122-03	3	122	126	2	2012	50	—	40	93	—	32	8	—	1.81
SPZ125-03	3	125	129	2	2012	50	—	40	96	—	32	8	—	1.90
SPZ129-03	3	129	133	2	2012	50	—	40	100	—	32	8	—	2.14
SPZ132-03	3	132	136	2	2012	50	—	40	103	—	32	8	—	2.27
SPZ135-03	3	135	139	2	2012	50	—	40	106	—	32	8	—	2.40
SPZ136-03	3	136	140	2	2012	50	—	40	107	—	32	8	—	2.47
SPZ140-03	3	140	144	2	2012	50	—	40	111	—	32	8	—	2.70
SPZ145-03	3	145	149	2	2012	50	—	40	116	—	32	8	—	2.90
SPZ150-03	3	150	154	2	2012	50	—	40	121	—	32	8	—	3.16
SPZ155-03	3	155	159	2	2012	50	—	40	126	—	32	8	—	3.50
SPZ160-03	3	160	164	2	2012	50	—	40	131	—	32	8	—	3.77
SPZ165-03	3	165	169	2	2012	50	—	40	136	—	32	8	—	4.60
SPZ170-03	3	170	174	3	2012	50	—	40	141	4	32	4	—	4.38
SPZ175-03	3	175	179	3	2012	50	—	40	146	4	32	4	—	4.66

P.M SPZ/03 P.M SPZ(P.3-P.13)

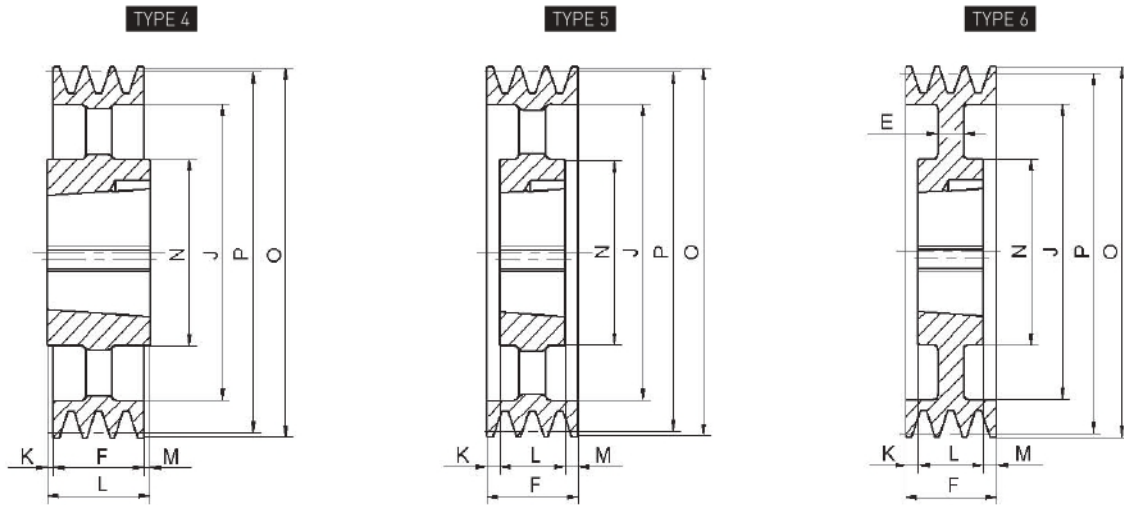

P.M SPZ/03

Product Model	Grooves	P	O	TYPE	BUSH	MAX Bore	E	F	J	K	L	M	N	Weight (Kg)
SPZ180-03	3	180	184	6	2012	50	7	40	151	—	32	8	106	3.36
SPZ185-03	3	185	189	6	2012	50	7	40	156	—	32	8	106	3.46
SPZ190-03	3	190	194	6	2012	50	10	40	161	4	32	4	112	3.95
SPZ195-03	3	195	199	6	2012	50	10	40	166	4	32	4	112	4.14
SPZ200-03	3	200	204	5	2012	50	—	40	171	4	32	4	112	4.15
SPZ212-03	3	212	216	5	2012	50	—	40	183	4	32	4	112	4.30
SPZ224-03	3	224	228	5	2012	50	—	40	195	4	32	4	112	4.68
SPZ236-03	3	236	240	5	2012	50	—	40	207	4	32	4	112	5.00
SPZ250-03	3	250	254	5	2012	50	—	40	221	4	32	4	112	5.35
SPZ265-03	3	265	269	4	2517	60	—	40	236	2.5	45	2.5	124	6.10
SPZ280-03	3	280	284	4	2517	60	—	40	251	2.5	45	2.5	124	6.53
SPZ315-03	3	315	319	4	2517	60	—	40	286	2.5	45	2.5	124	7.30
SPZ335-03	3	335	339	4	2517	60	—	40	306	2.5	45	2.5	124	7.99
SPZ355-03	3	355	359	4	2517	60	—	40	326	2.5	45	2.5	124	8.86
SPZ400-03	3	400	404	4	2517	60	—	40	371	2.5	45	2.5	124	10.50
SPZ450-03	3	450	454	4	2517	60	—	40	421	2.5	45	2.5	124	11.60
SPZ500-03	3	500	504	4	2517	60	—	40	471	2.5	45	2.5	124	13.30
SPZ560-03	3	560	564	4	2517	60	—	40	531	2.5	45	2.5	124	15.70
SPZ630-03	3	630	634	4	3020	75	—	40	601	5.5	51	5.5	150	20.10
SPZ800-03	3	800	804	4	3020	75	—	40	771	5.5	51	5.5	146	25.00

P.M SPZ/04

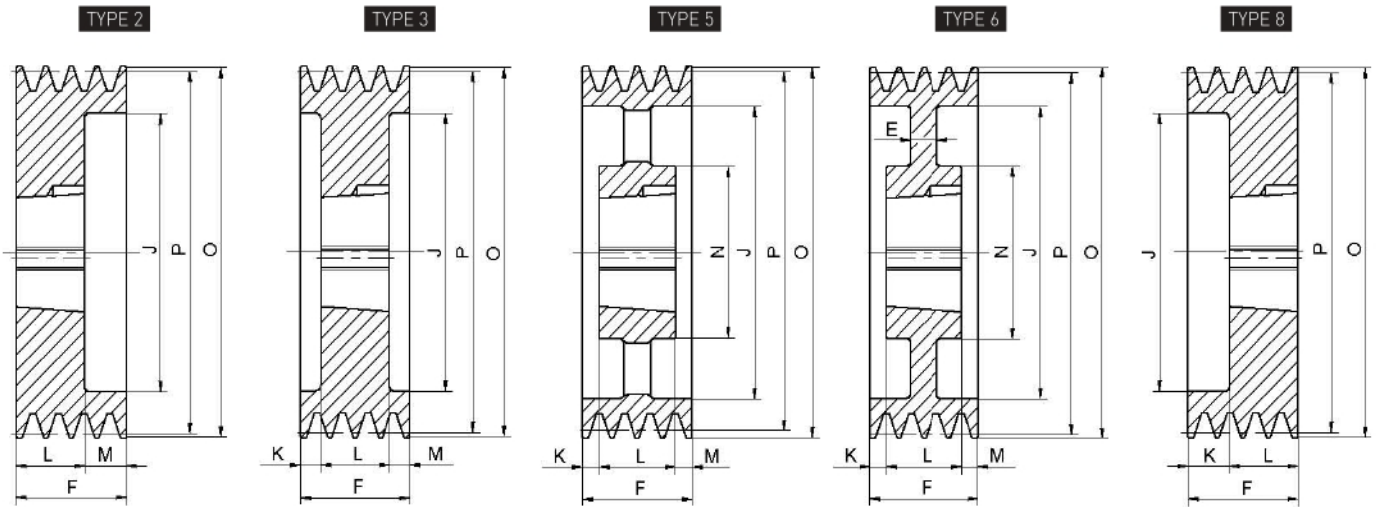

P.M SPZ/04

Product Model	Grooves	P	O	TYPE	BUSH	MAX Bore	E	F	J	K	L	M	N	Weight (Kg)
SPZ63-04	4	63	67	8	1108	28	—	52	36	30	22	—	—	0.55
SPZ67-04	4	67	71	8	1108	28	—	52	40	30	22	—	—	0.60
SPZ71-04	4	71	75	8	1108	28	—	52	42	30	22	—	—	0.74
SPZ75-04	4	75	79	8	1210	32	—	52	46	27	25	—	—	0.74
SPZ80-04	4	80	84	8	1210	32	—	52	51	27	25	—	—	0.87
SPZ85-04	4	85	89	8	1610	42	—	52	60	27	25	—	—	0.84
SPZ90-04	4	90	94	8	1610	42	—	52	61	27	25	—	—	1.08
SPZ95-04	4	95	99	8	1610	42	—	52	66	27	25	—	—	1.21
SPZ100-04	4	100	104	8	1610	42	—	52	71	27	25	—	—	1.38
SPZ106-04	4	106	110	8	1610	42	—	52	76	27	25	—	—	1.60
SPZ112-04	4	112	116	8	2012	50	—	52	83	20	32	—	—	1.65
SPZ118-04	4	118	122	8	2012	50	—	52	90	20	32	—	—	1.97
SPZ120-04	4	120	124	2	2012	50	—	52	91	—	32	20	—	2.07
SPZ125-04	4	125	129	2	2012	50	—	52	96	—	32	20	—	2.24
SPZ132-04	4	132	136	2	2012	50	—	52	103	—	32	20	—	2.60
SPZ135-04	4	135	139	2	2012	50	—	52	106	—	32	20	—	2.76
SPZ140-04	4	140	144	2	2012	50	—	52	111	—	32	20	—	3.00
SPZ150-04	4	150	154	2	2517	60	—	52	121	—	45	7	—	3.75
SPZ155-04	4	155	159	2	2517	60	—	52	126	—	45	7	—	4.11
SPZ160-04	4	160	164	2	2517	60	—	52	131	—	45	7	—	4.45
SPZ170-04	4	170	174	2	2517	60	—	52	141	—	45	7	—	5.30
SPZ180-04	4	180	184	2	2517	60	—	52	151	—	45	7	—	6.20
SPZ190-04	4	190	194	3	2517	60	—	52	161	3.5	45	3.5	—	7.10
SPZ200-04	4	200	204	6	2517	60	8	52	171	3.5	45	3.5	124	5.23
SPZ212-04	4	212	216	6	2517	60	12	52	183	3.5	45	3.5	124	5.95
SPZ224-04	4	224	228	5	2517	60	—	52	195	3.5	45	3.5	124	6.43
SPZ236-04	4	236	240	5	2517	60	—	52	207	3.5	45	3.5	124	7.29
SPZ250-04	4	250	254	5	2517	60	—	52	221	3.5	45	3.5	124	7.50
SPZ265-04	4	265	269	5	2517	60	—	52	236	3.5	45	3.5	124	8.71
SPZ280-04	4	280	284	5	2517	60	—	52	251	3.5	45	3.5	124	9.40
SPZ315-04	4	315	319	5	2517	60	—	52	286	3.5	45	3.5	124	8.45

P.M SPZ/04 P.M SPZ(P.3-P.13)

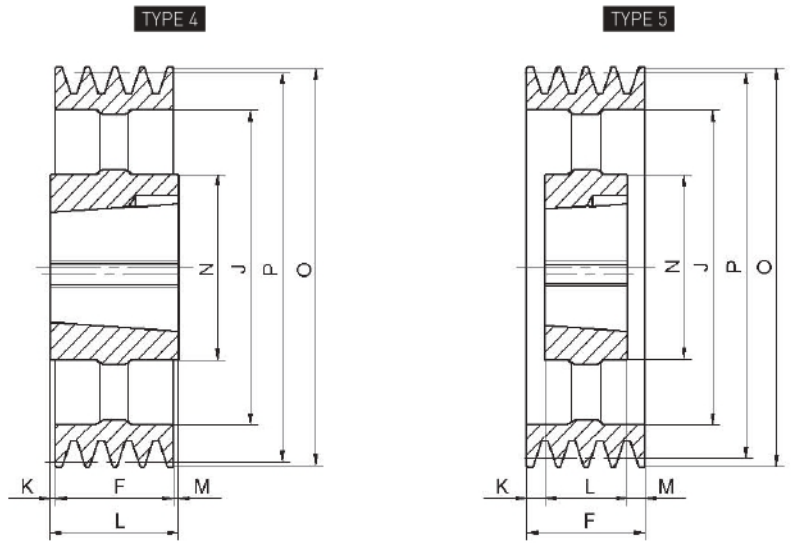

P.M SPZ/04

Product Model	Grooves	P	O	TYPE	BUSH	MAX Bore	E	F	J	K	L	M	N	Weight (Kg)
SPZ335-04	4	335	339	5	2517	60	—	52	306	3.5	45	3.5	124	9.57
SPZ355-04	4	355	359	5	2517	60	—	52	326	3.5	45	3.5	124	10.37
SPZ400-04	4	400	404	5	2517	60	—	52	371	3.5	45	3.5	124	12.94
SPZ450-04	4	450	454	5	3020	75	—	52	421	0.5	51	0.5	146	15.92
SPZ500-04	4	500	504	5	3020	75	—	52	471	0.5	51	0.5	146	18.00
SPZ630-04	4	630	634	4	3030	75	—	52	601	12	76	12	146	26.00
SPZ800-04	4	800	804	4	3030	75	—	52	771	12	76	12	146	33.00

P.M SPZ/05

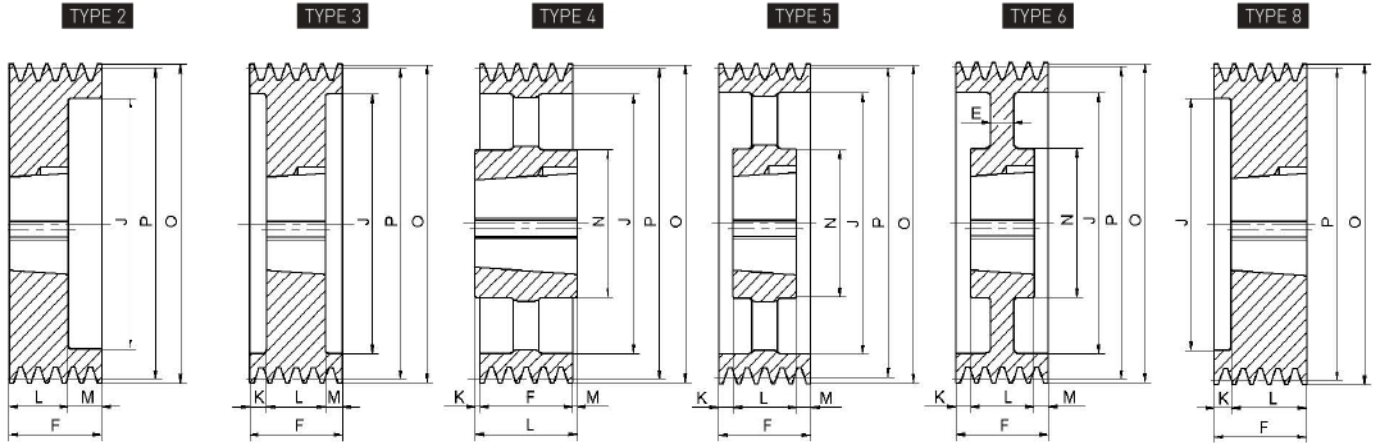

P.M SPZ/05

Product Model	Grooves	P	O	TYPE	BUSH	MAX Bore	E	F	J	K	L	M	N	Weight (Kg)
SPZ75-05	5	75	79	8	1210	32	—	64	46	39	25	—	—	0.91
SPZ85-05	5	85	89	8	1610	42	—	64	60	39	25	—	—	1.00
SPZ90-05	5	90	94	8	1610	42	—	64	61	39	25	—	—	1.29
SPZ95-05	5	95	99	8	1610	42	—	64	66	39	25	—	—	1.45
SPZ100-05	5	100	104	8	2012	50	—	64	71	32	32	—	—	1.40
SPZ106-05	5	106	110	8	2012	50	—	64	76	32	32	—	—	1.72
SPZ112-05	5	112	116	8	2012	50	—	64	83	32	32	—	—	1.90
SPZ118-05	5	118	122	8	2012	50	—	64	90	32	32	—	—	2.20
SPZ125-05	5	125	129	8	2012	50	—	64	96	32	32	—	—	2.63
SPZ132-05	5	132	136	8	2517	60	—	64	103	19	45	—	—	2.75
SPZ140-05	5	140	144	2	2517	60	—	64	111	—	45	19	—	3.34
SPZ150-05	5	150	154	2	2517	60	—	64	121	—	45	19	—	4.15
SPZ160-05	5	160	164	2	2517	60	—	64	131	—	45	19	—	4.93
SPZ170-05	5	170	174	2	2517	60	—	64	141	—	45	19	—	5.75
SPZ180-05	5	180	184	2	2517	60	—	64	151	—	45	19	—	6.72
SPZ190-05	5	190	194	3	2517	60	—	64	161	9.5	45	9.5	—	7.65
SPZ200-05	5	200	204	3	2517	60	—	64	171	9.5	45	9.5	—	8.63
SPZ212-05	5	212	216	6	2517	60	16	64	183	9.5	45	9.5	124	7.04
SPZ224-05	5	224	228	5	2517	60	—	64	195	9.5	45	9.5	124	7.59
SPZ236-05	5	236	240	5	2517	60	—	64	207	9.5	45	9.5	124	8.21
SPZ250-05	5	250	254	5	2517	60	—	64	221	9.5	45	9.5	124	8.30
SPZ265-05	5	265	269	5	2517	60	—	64	236	9.5	45	9.5	124	8.60
SPZ280-05	5	280	284	5	2517	60	—	64	251	9.5	45	9.5	124	9.00
SPZ315-05	5	315	319	5	2517	60	—	64	286	9.5	45	9.5	124	10.14
SPZ335-05	5	335	339	5	2517	60	—	64	306	9.5	45	9.5	124	11.80
SPZ355-05	5	355	359	5	2517	60	—	64	326	9.5	45	9.5	124	11.96
SPZ380-05	5	380	384	5	3020	75	—	64	351	6.5	51	6.5	146	13.80
SPZ400-05	5	400	404	5	3020	75	—	64	371	6.5	51	6.5	146	14.50
SPZ450-05	5	450	454	5	3020	75	—	64	421	6.5	51	6.5	146	17.55
SPZ500-05	5	500	504	4	3030	75	—	64	471	6	76	6	146	21.15
SPZ630-05	5	630	634	4	3030	75	—	64	601	6	76	6	146	25.30
SPZ710-05	5	710	714	4	3535	90	—	64	681	12.5	89	12.5	175	30.60
SPZ800-05	5	800	804	4	3535	90	—	64	771	12.5	89	12.5	178	39.00

P.M SPZ/06 P.M SPZ(P.3-P.13)

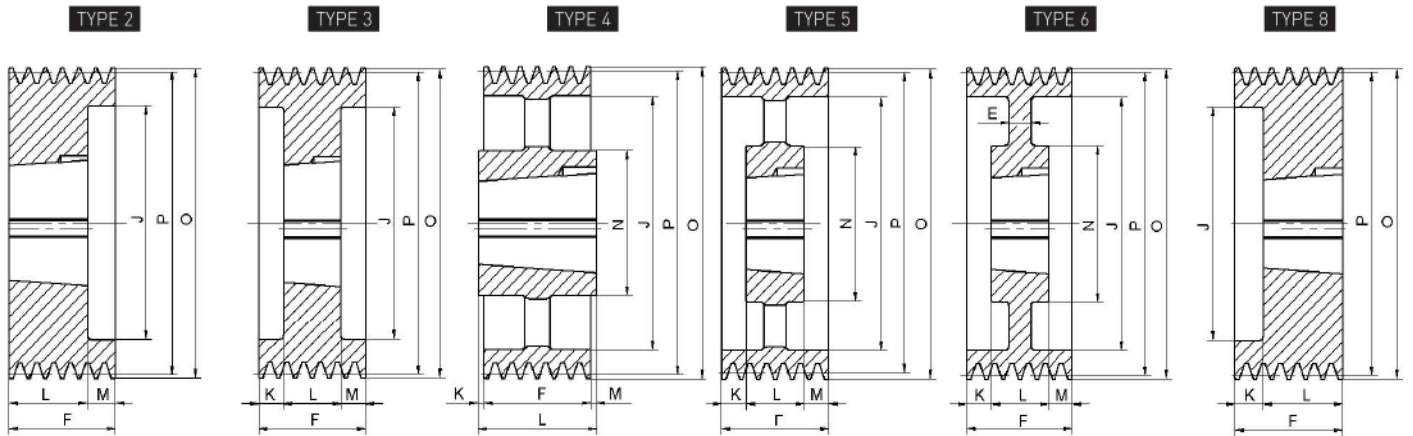

P.M SPZ/06

Product Model	Grooves	P	O	TYPE	BUSH	MAX Bore	E	F	J	K	L	M	N	Weight (Kg)
SPZ90-06	6	90	94	8	1610	42	—	76	61	51	25	—	—	1.50
SPZ95-06	6	95	99	8	1610	42	—	76	66	51	25	—	—	1.68
SPZ100-06	6	100	104	8	2012	50	—	76	71	44	32	—	—	1.65
SPZ106-06	6	106	110	8	2012	50	—	76	76	44	32	—	—	1.95
SPZ112-06	6	112	116	8	2012	50	—	76	83	44	32	—	—	2.25
SPZ118-06	6	118	122	8	2517	60	—	76	90	31	45	—	—	2.14
SPZ125-06	6	125	129	8	2517	60	—	76	96	31	45	—	—	2.60
SPZ132-06	6	132	136	8	2517	60	—	76	103	31	45	—	—	3.15
SPZ140-06	6	140	144	2	2517	60	—	76	111	—	45	31	—	3.70
SPZ150-06	6	150	154	2	2517	60	—	76	121	—	45	31	—	4.47
SPZ160-06	6	160	164	2	2517	60	—	76	131	—	45	31	—	4.90
SPZ170-06	6	170	174	2	2517	60	—	76	141	—	45	31	—	6.20
SPZ180-06	6	180	184	3	2517	60	—	76	151	15.5	45	15.5	—	7.12
SPZ190-06	6	190	194	3	2517	60	—	76	161	15.5	45	15.5	—	8.13
SPZ200-06	6	200	204	3	2517	60	—	76	171	15.5	45	15.5	—	9.28
SPZ212-06	6	212	216	6	2517	60	15	76	183	15.5	45	15.5	124	7.48
SPZ224-06	6	224	228	5	2517	60	—	76	195	15.5	45	15.5	124	7.42
SPZ236-06	6	236	240	5	2517	60	—	76	207	15.5	45	15.5	124	8.72
SPZ250-06	6	250	254	5	2517	60	—	76	221	15.5	45	15.5	124	9.43
SPZ280-06	6	280	284	5	2517	60	—	76	251	15.5	45	15.5	124	9.80
SPZ315-06	6	315	319	5	2517	60	—	76	286	15.5	45	15.5	124	11.00
SPZ355-06	6	355	359	5	2517	60	—	76	326	15.5	45	15.5	124	12.93
SPZ400-06	6	400	404	5	3030	75	—	76	371	—	76	—	146	17.40
SPZ450-06	6	450	454	5	3030	75	—	76	421	—	76	—	146	19.96
SPZ500-06	6	500	504	5	3030	75	—	76	471	—	76	—	146	22.50
SPZ630-06	6	630	634	4	3535	90	—	76	601	6.5	89	6.5	175	32.00
SPZ800-06	6	800	804	4	3535	90	—	76	771	6.5	89	6.5	178	60.20

P.M SPZ/08

TAPER BUSHING V-BELT PULLEYS
 ● P.M SPZ/06
 ● P.M SPZ/08

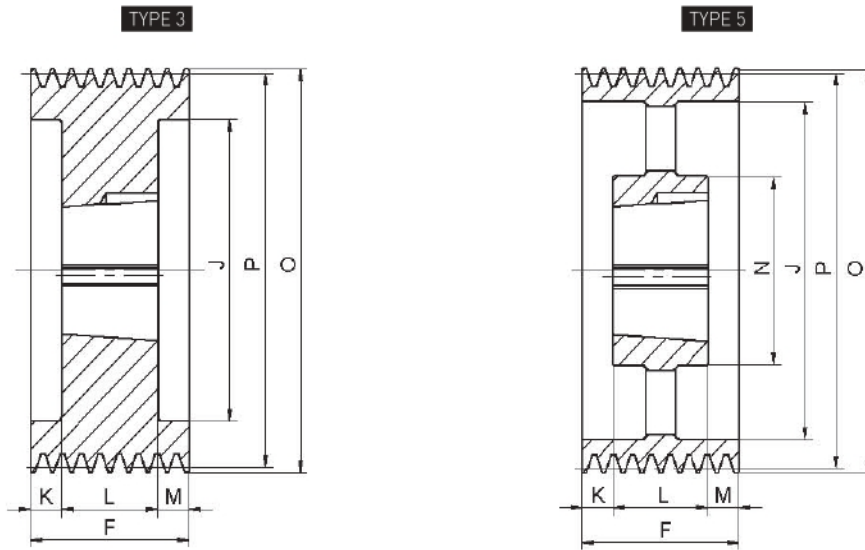

P.M SPZ/08

Product Model	Grooves	P	O	TYPE	BUSH	MAX Bore	E	F	J	K	L	M	N	Weight (Kg)
SPZ140-08	8	140	144	3	2517	60	—	100	111	27.5	45	27.5	—	4.49
SPZ150-08	8	150	154	3	2517	60	—	100	121	27.5	45	27.5	—	5.30
SPZ160-08	8	160	164	3	2517	60	—	100	131	27.5	45	27.5	—	6.15
SPZ170-08	8	170	174	3	2517	60	—	100	141	27.5	45	27.5	—	7.10
SPZ180-08	8	180	184	3	2517	60	—	100	151	27.5	45	27.5	—	8.92
SPZ190-08	8	190	194	3	3020	75	—	100	161	24.5	51	24.5	—	8.60
SPZ200-08	8	200	204	3	3020	75	—	100	171	24.5	51	24.5	—	9.75
SPZ224-08	8	224	228	3	3020	75	—	100	195	24.5	51	24.5	—	13.00
SPZ250-08	8	250	254	5	3020	75	—	100	221	24.5	51	24.5	146	11.49
SPZ280-08	8	280	284	5	3020	75	—	100	251	24.5	51	24.5	146	12.44
SPZ315-08	8	315	319	5	3020	75	—	100	286	24.5	51	24.5	146	13.45
SPZ355-08	8	355	359	5	3030	75	—	100	326	12	76	12	146	18.79
SPZ400-08	8	400	404	5	3030	75	—	100	371	12	76	12	146	21.75
SPZ450-08	8	450	454	5	3535	90	—	100	421	5.5	89	5.5	175	27.85
SPZ500-08	8	500	504	5	3535	90	—	100	471	5.5	89	5.5	175	30.20
SPZ630-08	8	630	634	5	3535	90	—	100	601	5.5	89	5.5	175	41.00
SPZ800-08	8	800	804	5	3535	90	—	100	771	5.5	89	5.5	178	53.00

P.M SPA/01

P.M SPA(P.14~P.24)

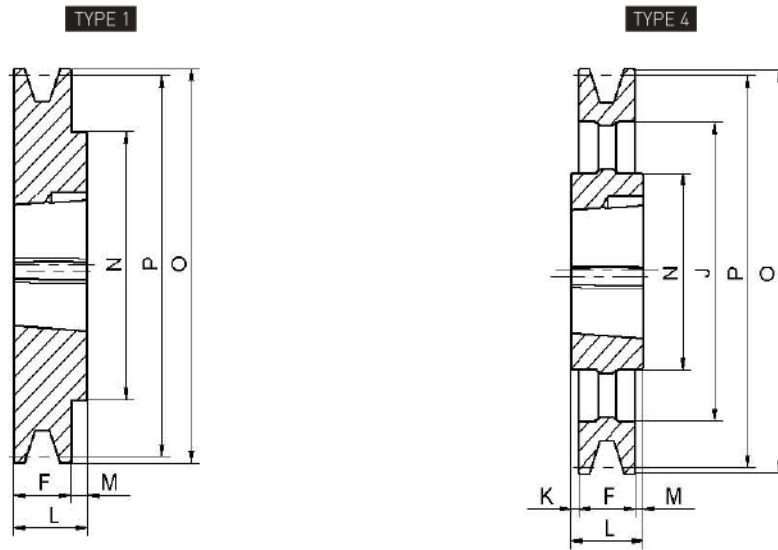

P.M SPA/01

Product Model	Grooves	P	O	TYPE	BUSH	MAX Bore	E	F	J	K	L	M	N	Weight (Kg)
SPA63-01	1	63	68.5	1	1008	25	—	20	—	—	22	2	56	0.26
SPA67-01	1	67	72.5	1	1108	28	—	20	—	—	22	2	56	0.28
SPA71-01	1	71	76.5	1	1108	28	—	20	—	—	22	2	60	0.35
SPA75-01	1	75	80.5	1	1108	28	—	20	—	—	22	2	60	0.40
SPA80-01	1	80	85.5	1	1210	32	—	20	—	—	25	5	75	0.46
SPA85-01	1	85	90.5	1	1210	32	—	20	—	—	25	5	80	0.55
SPA90-01	1	90	95.5	1	1210	42	—	20	—	—	25	5	80	0.65
SPA95-01	1	95	100.5	1	1210	32	—	20	—	—	25	5	85	0.79
SPA100-01	1	100	105.5	1	1610	42	—	20	—	—	25	5	85	0.75
SPA106-01	1	106	111.5	1	1610	42	—	20	—	—	25	5	92	0.92
SPA112-01	1	112	117.5	1	1610	42	—	20	—	—	25	5	92	1.06
SPA115-01	1	115	120.5	1	1610	42	—	20	—	—	25	5	92	1.15
SPA118-01	1	118	123.5	1	1610	42	—	20	—	—	25	5	92	1.20
SPA125-01	1	125	130.5	1	1610	42	—	20	—	—	25	5	92	1.41
SPA132-01	1	132	137.5	1	1610	42	—	20	—	—	25	5	92	1.60
SPA140-01	1	140	145.5	1	1610	42	—	20	—	—	25	5	92	1.85
SPA145-01	1	145	150.5	1	1610	42	—	20	—	—	25	5	92	2.01
SPA150-01	1	150	155.5	1	1610	42	—	20	—	—	25	5	92	2.15
SPA155-01	1	155	160.5	1	1610	42	—	20	—	—	25	5	92	2.33
SPA160-01	1	160	165.5	1	1610	42	—	20	—	—	25	5	92	2.50
SPA165-01	1	165	170.5	1	1610	42	—	20	—	—	25	5	92	2.66
SPA170-01	1	170	175.5	1	1610	42	—	20	—	—	25	5	92	2.85
SPA175-01	1	175	180.5	1	1610	42	—	20	—	—	25	5	92	3.02
SPA180-01	1	180	185.5	4	1610	42	—	20	145	—	25	5	92	2.21
SPA185-01	1	185	190.5	4	1610	42	—	20	150	—	25	5	92	2.35
SPA190-01	1	190	195.5	4	1610	42	—	20	156	—	25	5	92	2.31
SPA200-01	1	200	205.5	4	2012	50	—	20	165	—	32	12	108	3.00
SPA212-01	1	212	217.5	4	2012	50	—	20	177	—	32	12	110	3.10
SPA224-01	1	224	229.5	4	2012	50	—	20	189	—	32	12	112	3.33
SPA236-01	1	236	241.5	4	2012	50	—	20	202	—	32	12	112	3.62
SPA243-01	1	243	248.5	4	2012	50	—	20	208	—	32	12	112	3.65

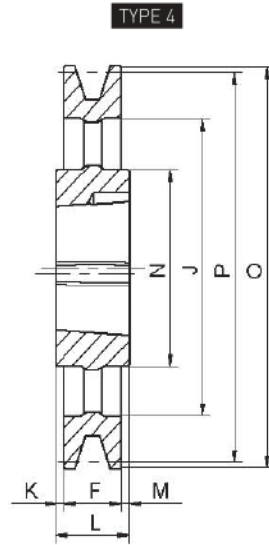

P.M SPA/01

Product Model	Grooves	P	O	TYPE	BUSH	MAX Bore	E	F	J	K	L	M	N	Weight (Kg)
SPA250-01	1	250	255.5	4	2012	50	—	20	215	6	32	6	112	3.73
SPA265-01	1	265	270.5	4	2012	50	—	20	230	6	32	6	112	4.02
SPA280-01	1	280	285.5	4	2012	50	—	20	245	—	32	12	112	4.08
SPA300-01	1	300	305.5	4	2012	50	—	20	265	—	32	12	112	4.62
SPA315-01	1	315	320.5	4	2012	50	—	20	280	—	32	12	112	4.75
SPA335-01	1	335	340.5	4	2012	50	—	20	300	—	32	12	112	5.24
SPA355-01	1	355	360.5	4	2012	50	—	20	320	—	32	12	112	5.57
SPA375-01	1	375	380.5	4	2012	50	—	20	340	—	32	12	112	6.18
SPA400-01	1	400	405.5	4	2012	50	—	20	365	—	32	12	112	6.40
SPA425-01	1	425	430.5	4	2012	50	—	20	390	—	32	12	112	7.50
SPA450-01	1	450	455.5	4	2012	50	—	20	415	—	32	12	112	7.45
SPA475-01	1	475	480.5	4	2517	60	—	20	440	—	45	25	124	9.00
SPA500-01	1	500	505.5	4	2517	60	—	20	465	—	45	25	124	9.30
SPA530-01	1	530	535.5	4	2517	60	—	20	495	—	45	25	124	10.73
SPA560-01	1	560	565.5	4	2517	60	—	20	525	—	45	25	124	11.00
SPA630-01	1	630	635.5	4	2517	60	—	20	595	—	45	25	124	12.55
SPA800-01	1	800	805.5	4	3020	75	—	20	765	15.5	51	15.5	159	19.00

P.M SPA/02

P.M SPA(P.14-P.24)

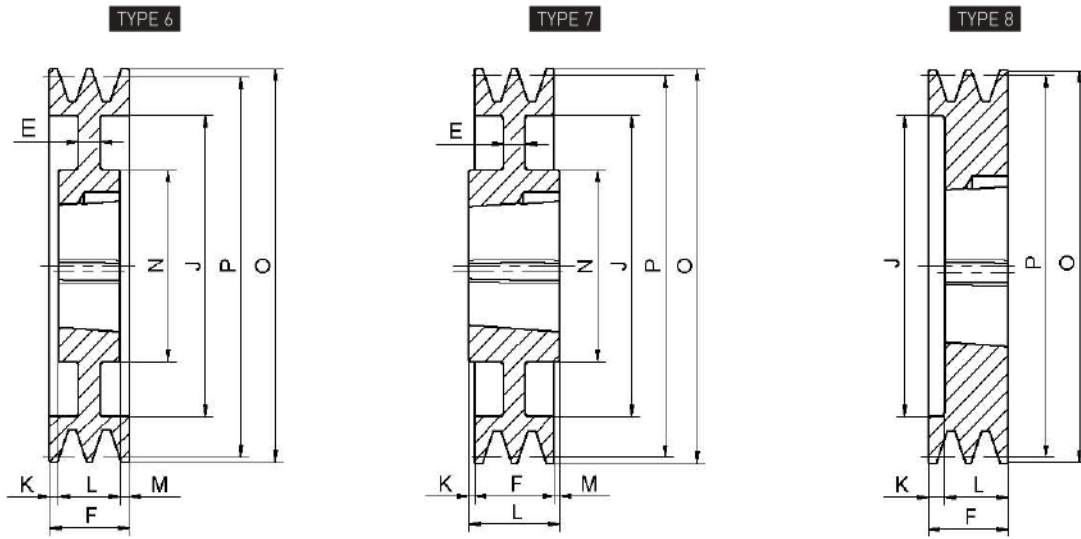

P.M SPA/02

Product Model	Grooves	P	O	TYPE	BUSH	MAX Bore	E	F	J	K	L	M	N	Weight (Kg)
*SPA63-02	2	63	68.5	8	1008	25	—	35	32.5	13	22	—	—	0.43
SPA67-02	2	67	72.5	8	1108	28	—	35	37	13	22	—	—	0.44
SPA71-02	2	71	76.5	8	1108	28	—	35	40	13	22	—	—	0.51
SPA75-02	2	75	80.5	8	1108	28	—	35	44	13	22	—	—	0.59
SPA80-02	2	80	85.5	8	1210	32	—	35	50	10	25	—	—	0.55
SPA85-02	2	85	90.5	8	1210	32	—	35	55	10	25	—	—	0.70
SPA90-02	2	90	95.5	8	1610	42	—	35	59	10	25	—	—	0.70
SPA95-02	2	95	100.5	8	1610	42	—	35	63	10	25	—	—	0.83
SPA100-02	2	100	105.5	8	1610	42	—	35	66	10	25	—	—	1.00
SPA105-02	2	105	110.5	8	1610	42	—	35	72	10	25	—	—	1.12
SPA106-02	2	106	111.5	8	1610	42	—	35	72	10	25	—	—	1.15
SPA112-02	2	112	117.5	8	1610	42	—	35	78	10	25	—	—	1.39
SPA115-02	2	115	120.5	8	1610	42	—	35	81	10	25	—	—	1.45
SPA118-02	2	118	123.5	8	1610	42	—	35	84	10	25	—	—	1.57
SPA125-02	2	125	130.5	8	1610	42	—	35	91	10	25	—	—	1.85
SPA130-02	2	130	135.5	8	2012	50	—	35	96	3	32	—	—	2.00
SPA132-02	2	132	137.5	8	2012	50	—	35	98	3	32	—	—	2.10
SPA140-02	2	140	145.5	8	2012	50	—	35	106	3	32	—	—	2.25
SPA145-02	2	145	150.5	8	2012	50	—	35	111	3	32	—	—	2.70
SPA150-02	2	150	155.5	8	2012	50	—	35	116	3	32	—	—	3.00
SPA155-02	2	155	160.5	8	2012	50	—	35	120	3	32	—	—	3.24
SPA160-02	2	160	165.5	8	2012	50	—	35	125	3	32	—	—	3.50
SPA165-02	2	165	170.5	8	2012	50	—	35	130	3	32	—	—	3.75
SPA170-02	2	170	175.5	8	2012	50	—	35	135	3	32	—	—	4.10
SPA175-02	2	175	180.5	8	2012	50	—	35	140	3	32	—	—	4.40
SPA180-02	2	180	185.5	6	2012	50	10	35	146	1.5	32	1.5	108	3.54
SPA185-02	2	185	190.5	6	2012	50	10	35	151	1.5	32	1.5	108	3.75
SPA190-02	2	190	195.5	6	2012	50	10	35	156	1.5	32	1.5	108	3.84
SPA195-02	2	195	200.5	6	2012	50	10	35	160	1.5	32	1.5	108	3.95
SPA200-02	2	200	205.5	7	2517	60	10	35	165	5	45	5	123	4.70
SPA205-02	2	205	210.5	7	2517	60	10	35	170	5	45	5	123	4.85
SPA210-02	2	210	215.5	7	2517	60	10	35	175	5	45	5	123	5.02

* * * : Material steel

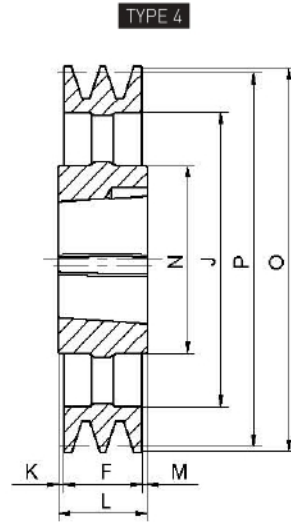

P.M SPA/02

Product Model	Grooves	P	O	TYPE	BUSH	MAX Bore	E	F	J	K	L	M	N	Weight (Kg)
SPA212-02	2	212	217.5	4	2517	60	—	35	177	5	45	5	123	4.93
SPA215-02	2	215	220.5	4	2517	60	—	35	180	5	45	5	123	5.10
SPA218-02	2	218	223.5	4	2517	60	—	35	183	5	45	5	123	5.12
SPA224-02	2	224	229.5	4	2517	60	—	35	189	—	45	10	124	5.17
SPA230-02	2	230	235.5	4	2517	60	—	35	195	—	45	10	124	5.19
SPA236-02	2	236	241.5	4	2517	60	—	35	202	—	45	10	124	5.20
SPA243-02	2	243	248.5	4	2517	60	—	35	208	—	45	10	124	5.65
SPA250-02	2	250	255.5	4	2517	60	—	35	215	5	45	5	124	5.82
SPA258-02	2	258	263.5	4	2517	60	—	35	223	—	45	10	124	5.93
SPA265-02	2	265	270.5	4	2517	60	—	35	230	—	45	10	124	6.15
SPA273-02	2	273	278.5	4	2517	60	—	35	238	—	45	10	124	6.35
SPA280-02	2	280	285.5	4	2517	60	—	35	245	—	45	10	124	6.45
SPA290-02	2	290	295.5	4	2517	60	—	35	255	—	45	10	124	6.90
SPA300-02	2	300	305.5	4	2517	60	—	35	265	—	45	10	124	6.95
SPA315-02	2	315	320.5	4	2517	60	—	35	280	—	45	10	124	7.34
SPA325-02	2	325	330.5	4	2517	60	—	35	290	—	45	10	124	8.05
SPA335-02	2	335	340.5	4	2517	60	—	35	300	—	45	10	124	8.35
SPA340-02	2	340	345.5	4	2517	60	—	35	305	—	45	10	124	9.32
SPA345-02	2	345	350.5	4	2517	60	—	35	310	—	45	10	124	9.35
SPA355-02	2	355	360.5	4	2517	60	—	35	320	—	45	10	124	9.36
SPA375-02	2	375	380.5	4	2517	60	—	35	340	—	45	10	124	9.38
SPA400-02	2	400	405.5	4	2517	60	—	35	365	—	45	10	124	10.20
SPA425-02	2	425	430.5	4	2517	60	—	35	390	—	45	10	124	10.85
SPA450-02	2	450	455.5	4	2517	60	—	35	415	—	45	10	124	11.64
SPA475-02	2	475	480.5	4	2517	60	—	35	440	—	45	10	124	12.50
SPA500-02	2	500	505.5	4	2517	60	—	35	465	—	45	10	125	13.25
SPA530-02	2	530	535.5	4	3020	75	—	35	495	8	51	8	159	16.00
SPA560-02	2	560	565.5	4	3020	75	—	35	525	8	51	8	159	16.55
SPA630-02	2	630	635.5	4	3020	75	—	35	595	8	51	8	159	19.10
SPA710-02	2	710	715.5	4	3020	75	—	35	675	8	51	8	159	23.40
SPA745-02	2	745	750.5	4	3535	90	—	35	710	27	89	27	175	31.55
SPA800-02	2	800	805.5	4	3535	90	—	35	765	27	89	27	175	34.00
SPA900-02	2	900	905.5	4	3535	90	—	35	865	27	89	27	175	37.00

P.M SPA/03

P.M SPA(P.14~P.24)

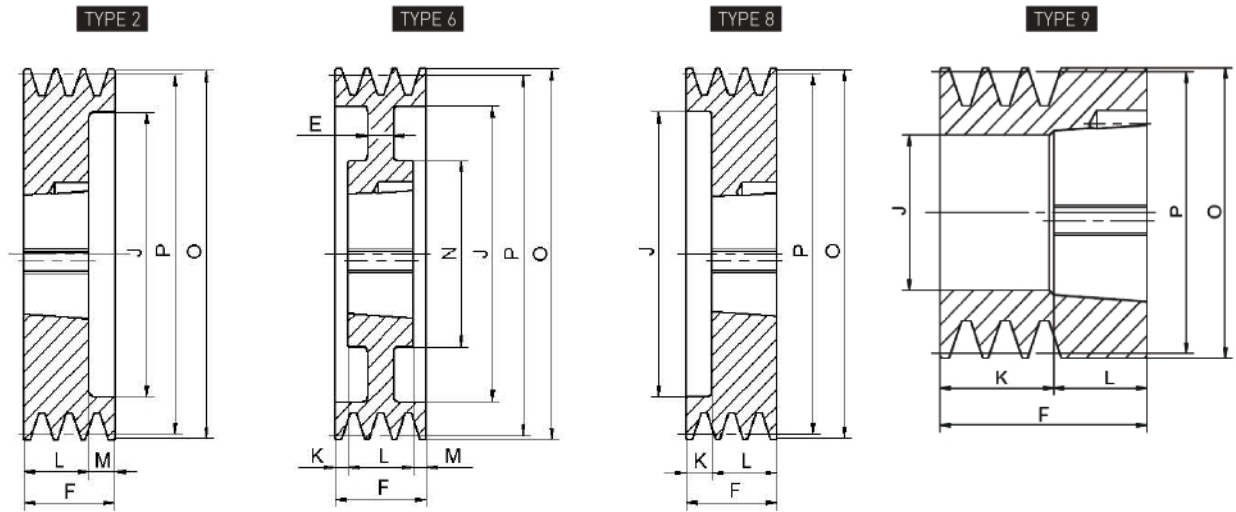

P.M SPA/03

Product Model	Grooves	P	O	TYPE	BUSH	MAX Bore	E	F	J	K	L	M	N	Weight (Kg)
SPA63-03	3	63	68.5	9	1108	28	—	70	28	46	24	—	—	0.99
SPA67-03	3	67	72.5	8	1108	28	—	50	37	28	22	—	—	0.60
SPA71-03	3	71	76.5	8	1108	28	—	50	40	28	22	—	—	0.70
SPA75-03	3	75	80.5	8	1108	28	—	50	44	28	22	—	—	0.80
SPA80-03	3	80	85.5	8	1210	32	—	50	50	25	25	—	—	0.80
SPA85-03	3	85	90.5	8	1210	32	—	50	55	25	25	—	—	0.94
SPA90-03	3	90	95.5	8	1610	42	—	50	59	25	25	—	—	0.95
SPA95-03	3	95	100.5	8	1610	42	—	50	63	25	25	—	—	1.12
SPA100-03	3	100	105.5	2	1610	42	—	50	66	—	25	25	—	1.30
SPA105-03	3	105	110.5	2	1610	42	—	50	72	—	25	25	—	1.45
SPA106-03	3	106	111.5	2	1610	42	—	50	72	—	25	25	—	1.52
SPA112-03	3	112	117.5	8	2012	50	—	50	78	18	32	—	—	1.57
SPA115-03	3	115	120.5	2	2012	50	—	50	81	—	32	18	—	1.67
SPA118-03	3	118	123.5	2	2012	50	—	50	84	—	32	18	—	1.85
SPA125-03	3	125	130.5	2	2012	50	—	50	91	—	32	18	—	2.20
SPA130-03	3	130	135.5	2	2012	50	—	50	96	—	32	18	—	2.45
SPA132-03	3	132	137.5	2	2012	50	—	50	98	—	32	18	—	2.53
SPA140-03	3	140	145.5	8	2517	60	—	50	106	5	45	—	—	2.87
SPA145-03	3	145	150.5	8	2517	60	—	50	111	5	45	—	—	3.15
SPA150-03	3	150	155.5	8	2517	60	—	50	116	5	45	—	—	3.55
SPA155-03	3	155	160.5	8	2517	60	—	50	120	5	45	—	—	3.90
SPA160-03	3	160	165.5	8	2517	60	—	50	125	5	45	—	—	4.33
SPA165-03	3	165	170.5	8	2517	60	—	50	130	5	45	—	—	4.75
SPA170-03	3	170	175.5	8	2517	60	—	50	135	5	45	—	—	5.10
SPA175-03	3	175	180.5	8	2517	60	—	50	140	5	45	—	—	5.60
SPA180-03	3	180	185.5	8	2517	60	—	50	146	5	45	—	—	6.00
SPA185-03	3	185	190.5	8	2517	60	—	50	150	5	45	—	—	6.25
SPA190-03	3	190	195.5	8	2517	60	—	50	156	5	45	—	—	6.92
SPA195-03	3	195	200.5	8	2517	60	—	50	160	5	45	—	—	7.40
SPA200-03	3	200	205.5	6	2517	60	20	50	165	2.5	45	2.5	123	6.15
SPA205-03	3	205	210.5	6	2517	60	20	50	170	2.5	45	2.5	123	6.74
SPA210-03	3	210	215.5	6	2517	60	20	50	175	2.5	45	2.5	123	6.70

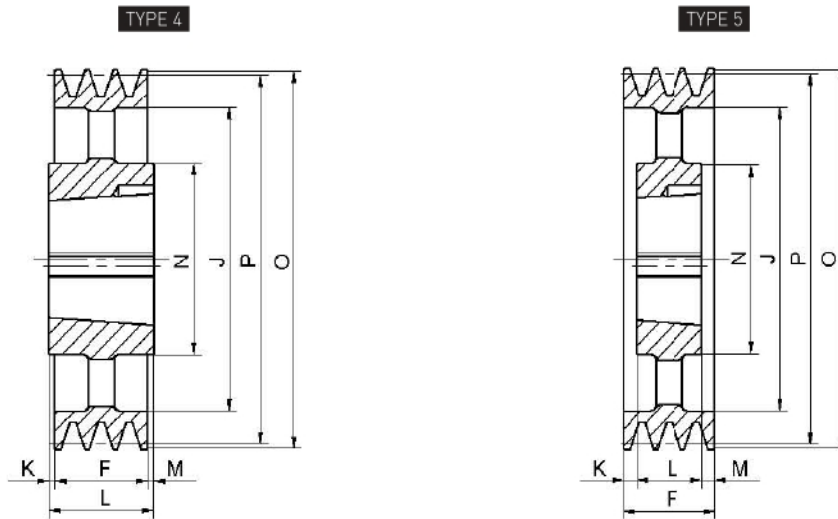

P.M SPA/03

Product Model	Grooves	P	O	TYPE	BUSH	MAX Bore	E	F	J	K	L	M	N	Weight (Kg)
SPA212-03	3	212	217.5	5	2517	60	—	50	177	2.5	45	2.5	123	6.03
SPA215-03	3	215	220.5	5	2517	60	—	50	180	2.5	45	2.5	123	6.08
SPA218-03	3	218	223.5	5	2517	60	—	50	183	2.5	45	2.5	123	6.20
SPA224-03	3	224	229.5	5	2517	60	—	50	189	2.5	45	2.5	124	6.40
SPA230-03	3	230	235.5	5	2517	60	—	50	195	2.5	45	2.5	124	6.76
SPA236-03	3	236	241.5	5	2517	60	—	50	202	2.5	45	2.5	124	6.80
SPA243-03	3	243	248.5	5	2517	60	—	50	208	2.5	45	2.5	124	7.08
SPA250-03	3	250	255.5	5	2517	60	—	50	215	2.5	45	2.5	124	7.25
SPA258-03	3	258	263.5	5	2517	60	—	50	223	2.5	45	2.5	124	7.42
SPA265-03	3	265	270.5	5	2517	60	—	50	230	2.5	45	2.5	124	7.65
SPA273-03	3	273	278.5	5	2517	60	—	50	238	2.5	45	2.5	124	7.90
SPA280-03	3	280	285.5	5	2517	60	—	50	245	2.5	45	2.5	124	8.15
SPA290-03	3	290	295.5	5	2517	60	—	50	255	2.5	45	2.5	124	8.70
SPA300-03	3	300	305.5	4	3020	75	—	50	265	0.5	51	0.5	150	10.04
SPA315-03	3	315	320.5	4	3020	75	—	50	280	0.5	51	0.5	159	11.32
SPA335-03	3	335	340.5	4	3020	75	—	50	300	0.5	51	0.5	159	12.04
SPA350-03	3	350	355.5	4	3020	75	—	50	315	0.5	51	0.5	159	12.30
SPA355-03	3	355	360.5	4	3020	75	—	50	320	0.5	51	0.5	159	12.75
SPA375-03	3	375	380.5	4	3020	75	—	50	340	0.5	51	0.5	159	13.70
SPA400-03	3	400	405.5	4	3020	75	—	50	365	—	51	1	159	14.46
SPA425-03	3	425	430.5	4	3020	75	—	50	390	—	51	1	159	15.30
SPA450-03	3	450	455.5	4	3020	75	—	50	415	—	51	1	159	16.70
SPA475-03	3	475	480.5	4	3020	75	—	50	400	—	51	1	159	18.09
SPA500-03	3	500	505.5	4	3020	75	—	50	465	—	51	1	159	19.17
SPA520-03	3	520	525.5	4	3020	75	—	50	485	—	51	1	159	19.20
SPA530-03	3	530	535.5	4	3020	75	—	50	495	—	51	1	159	20.63
SPA560-03	3	560	565.5	4	3020	75	—	50	525	—	51	1	159	21.45
SPA630-03	3	630	635.5	4	3020	75	—	50	595	—	51	1	159	25.20
SPA745-03	3	745	750.5	4	3535	90	—	50	710	19.5	89	19.5	175	36.40
SPA800-03	3	800	805.5	4	3535	90	—	50	765	19.5	89	19.5	175	40.00
SPA900-03	3	900	905.5	4	3535	90	—	50	865	19.5	89	19.5	175	47.00
SPA1000-03	3	1000	1005.5	4	3535	90	—	50	965	19.5	89	19.5	175	50.00

P.M SPA/04

P.M SPA(P.14-P.24)

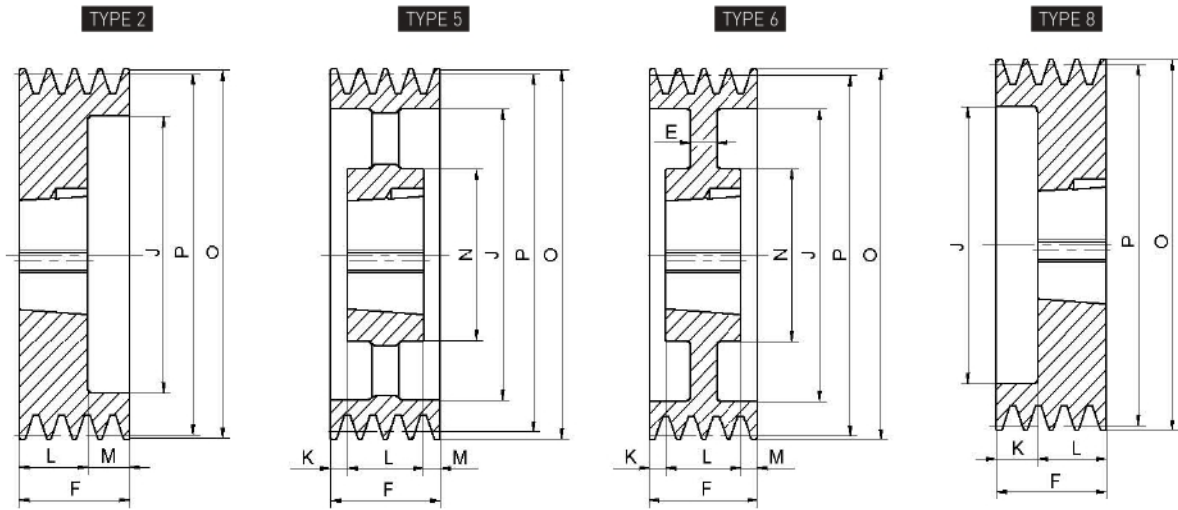

P.M SPA/04

Product Model	Grooves	P	O	TYPE	BUSH	MAX Bore	E	F	J	K	L	M	N	Weight (Kg)
SPA71-04	4	71	76.5	8	1108	28	—	65	40	43	22	—	—	1.47
SPA80-04	4	80	85.5	8	1210	32	—	65	49	40	25	—	—	1.05
SPA85-04	4	85	90.5	8	1210	32	—	65	54	40	25	—	—	1.20
SPA90-04	4	90	95.5	8	1615	42	—	65	59	27	38	—	—	1.25
SPA95-04	4	95	100.5	8	1615	42	—	65	63	27	38	—	—	1.50
SPA100-04	4	100	105.5	2	1615	42	—	65	66	—	38	27	—	1.75
SPA106-04	4	106	111.5	8	2012	50	—	65	72	33	32	—	—	1.66
SPA112-04	4	112	117.5	8	2012	50	—	65	78	33	32	—	—	1.90
SPA118-04	4	118	123.5	2	2012	50	—	65	84	—	32	33	—	2.22
SPA120-04	4	120	125.5	2	2012	50	—	65	86	—	32	33	—	2.41
SPA125-04	4	125	130.5	2	2012	50	—	65	91	—	32	33	—	2.63
SPA132-04	4	132	137.5	2	2517	60	—	65	98	—	45	20	—	2.79
SPA135-04	4	135	140.5	2	2517	60	—	65	101	—	45	20	—	2.99
SPA140-04	4	140	145.5	2	2517	60	—	65	106	—	45	20	—	3.35
SPA145-04	4	145	150.5	2	2517	60	—	65	111	—	45	20	—	3.74
SPA150-04	4	150	155.5	2	2517	60	—	65	116	—	45	20	—	4.05
SPA155-04	4	155	160.5	2	2517	60	—	65	120	—	45	20	—	4.56
SPA160-04	4	160	165.5	2	2517	60	—	65	125	—	45	20	—	4.90
SPA165-04	4	165	170.5	2	2517	60	—	65	130	—	45	20	—	5.36
SPA170-04	4	170	175.5	2	2517	60	—	65	135	—	45	20	—	5.75
SPA175-04	4	175	180.5	2	2517	60	—	65	140	—	45	20	—	6.25
SPA180-04	4	180	185.5	2	2517	60	—	65	146	—	45	20	—	6.65
SPA190-04	4	190	195.5	2	2517	60	—	65	156	—	45	20	—	7.55
SPA200-04	4	200	205.5	2	3020	75	—	65	165	—	51	14	—	8.10
SPA212-04	4	212	217.5	2	3020	75	—	65	177	—	51	14	—	9.55
SPA215-04	4	215	220.5	2	3020	75	—	65	180	—	51	14	—	9.96
SPA224-04	4	224	229.5	2	3020	75	—	65	189	—	51	14	—	11.06
SPA230-04	4	230	235.5	6	3020	75	20	65	195	—	51	14	159	9.67
SPA236-04	4	236	241.5	6	3020	75	20	65	202	—	51	14	159	9.85
SPA250-04	4	250	255.5	5	3020	75	—	65	215	7	51	7	159	9.95
SPA265-04	4	265	270.5	5	3020	75	—	65	230	7	51	7	159	10.73

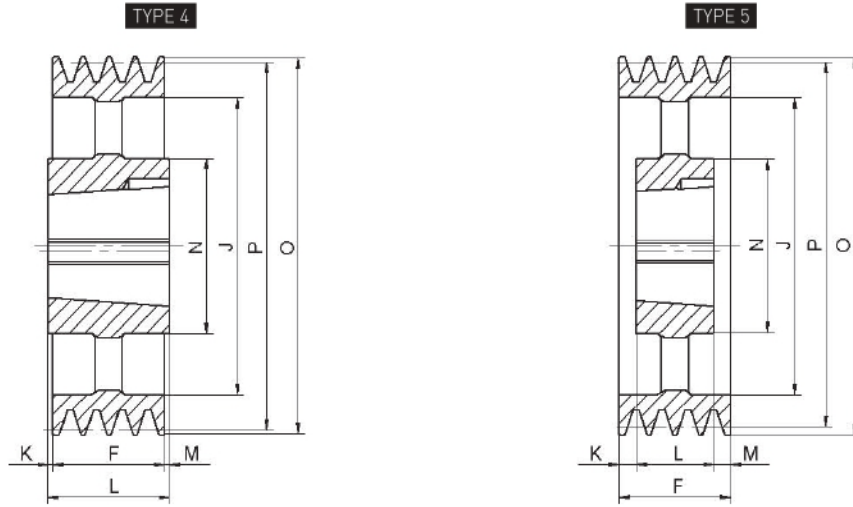

P.M SPA/04

Product Model	Grooves	P	O	TYPE	BUSH	MAX Bore	E	F	J	K	L	M	N	Weight (Kg)
SPA280-04	4	280	285.5	5	3020	75	—	65	245	7	51	7	159	11.40
SPA290-04	4	290	295.5	5	3020	75	—	65	255	7	51	7	159	12.00
SPA300-04	4	300	305.5	5	3020	75	—	65	265	7	51	7	159	12.25
SPA315-04	4	315	320.5	5	3020	75	—	65	280	7	51	7	159	12.95
SPA325-04	4	325	330.5	5	3020	75	—	65	290	7	51	7	159	13.45
SPA335-04	4	335	340.5	5	3020	75	—	65	300	7	51	7	159	13.50
SPA355-04	4	355	360.5	5	3020	75	—	65	320	7	51	7	159	14.48
SPA375-04	4	375	380.5	5	3020	75	—	65	340	7	51	7	159	15.30
SPA400-04	4	400	405.5	5	3020	75	—	65	365	7	51	7	159	16.42
SPA425-04	4	425	430.5	5	3020	75	—	65	390	7	51	7	159	18.47
SPA450-04	4	450	455.5	5	3020	75	—	65	415	7	51	7	159	19.45
SPA475-04	4	475	480.5	5	3020	75	—	65	440	7	51	7	159	20.84
SPA500-04	4	500	505.5	5	3020	75	—	65	465	7	51	7	159	21.90
SPA560-04	4	560	565.5	4	3535	90	—	65	525	12	89	12	175	28.50
SPA630-04	4	630	635.5	4	3535	90	—	65	595	12	89	12	175	32.55
SPA745-04	4	745	750.5	4	3535	90	—	65	710	12	89	12	175	41.15
SPA800-04	4	800	805.5	4	3535	90	—	65	765	12	89	12	175	45.05
SPA900-04	4	900	905.5	4	3535	90	—	65	865	12	89	12	175	51.00
SPA1000-04	4	1000	1005.5	4	4040	100	—	65	965	18.5	102	18.5	210	62.00

P.M SPA/05

P.M SPA(P.14-P.24)

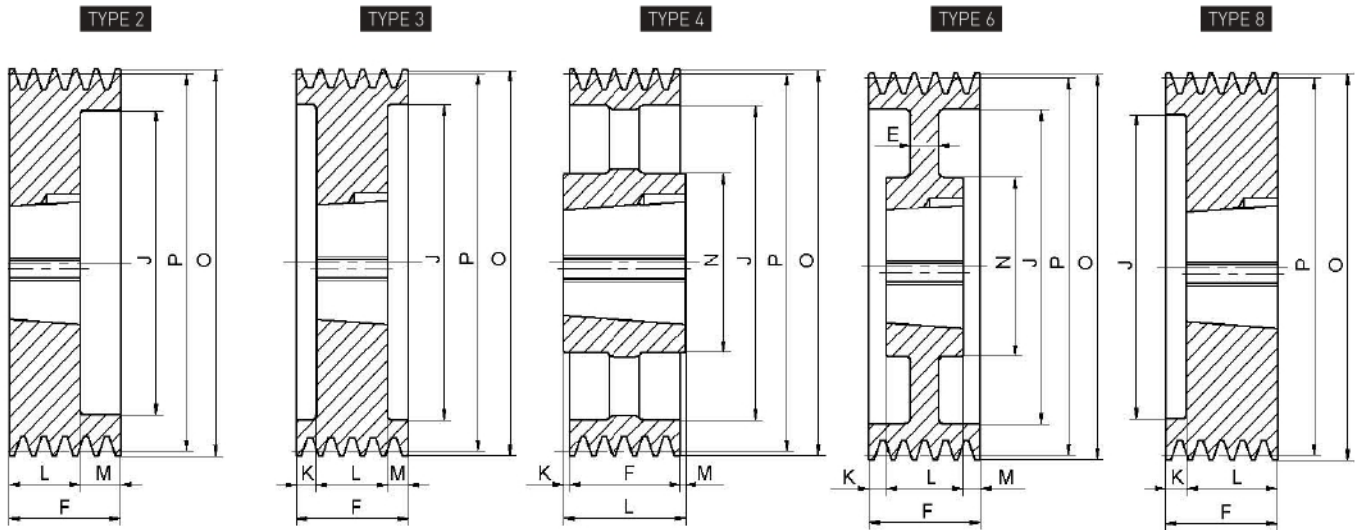

P.M SPA/05

Product Model	Grooves	P	O	TYPE	BUSH	MAX Bore	E	F	J	K	L	M	N	Weight (Kg)
SPA90-05	5	90	95.5	8	1615	42	—	80	58	42	38	—	—	1.51
SPA95-05	5	95	100.5	8	1615	42	—	80	63	42	38	—	—	1.75
SPA100-05	5	100	105.5	2	1615	42	—	80	66	—	38	42	—	2.06
SPA106-05	5	106	111.5	8	2012	50	—	80	72	48	32	—	—	2.01
SPA112-05	5	112	117.5	8	2012	50	—	80	78	48	32	—	—	2.31
SPA118-05	5	118	123.5	2	2012	50	—	80	84	—	32	48	—	2.60
SPA125-05	5	125	130.5	3	2012	50	—	80	91	24	32	24	—	3.10
SPA130-05	5	130	135.5	3	2517	60	—	80	96	17.5	45	17.5	—	3.14
SPA132-05	5	132	137.5	3	2517	60	—	80	98	17.5	45	17.5	—	3.24
SPA140-05	5	140	145.5	3	2517	60	—	80	106	17.5	45	17.5	—	3.85
SPA145-05	5	145	150.5	3	2517	60	—	80	111	17.5	45	17.5	—	4.17
SPA150-05	5	150	155.5	3	2517	60	—	80	116	17.5	45	17.5	—	4.62
SPA160-05	5	160	165.5	3	2517	60	—	80	125	17.5	45	17.5	—	5.55
SPA165-05	5	165	170.5	3	2517	60	—	80	130	17.5	45	17.5	—	6.00
SPA170-05	5	170	175.5	3	2517	60	—	80	135	17.5	45	17.5	—	6.45
SPA180-05	5	180	185.5	3	3020	75	—	80	146	14.5	51	14.5	—	6.60
SPA190-05	5	190	195.5	2	3020	75	—	80	156	—	51	29	—	7.70
SPA200-05	5	200	205.5	3	3020	75	—	80	165	14.5	51	14.5	—	8.94
SPA212-05	5	212	217.5	2	3020	75	—	80	177	—	51	29	—	10.35
SPA224-05	5	224	229.5	2	3020	75	—	80	189	—	51	29	—	11.95
SPA236-05	5	236	241.5	2	3020	75	—	80	202	—	51	29	—	13.60
SPA250-05	5	250	255.5	6	3020	75	20	80	215	14.5	51	14.5	159	12.06
SPA265-05	5	265	270.5	6	3020	75	20	80	230	14.5	51	14.5	159	13.20
SPA280-05	5	280	285.5	4	3535	90	—	80	245	4.5	89	4.5	175	16.25
SPA300-05	5	300	305.5	4	3535	90	—	80	265	4.5	89	4.5	175	17.12
SPA315-05	5	315	320.5	4	3535	90	—	80	280	4.5	89	4.5	175	17.86
SPA335-05	5	335	340.5	4	3535	90	—	80	300	4.5	89	4.5	175	19.31
SPA355-05	5	355	360.5	4	3535	90	—	80	320	4.5	89	4.5	175	20.75
SPA375-05	5	375	380.5	4	3535	90	—	80	340	4.5	89	4.5	175	22.00
SPA400-05	5	400	405.5	4	3535	90	—	80	365	4.5	89	4.5	175	22.83
SPA425-05	5	425	430.5	4	3535	90	—	80	390	4.5	89	4.5	175	23.00

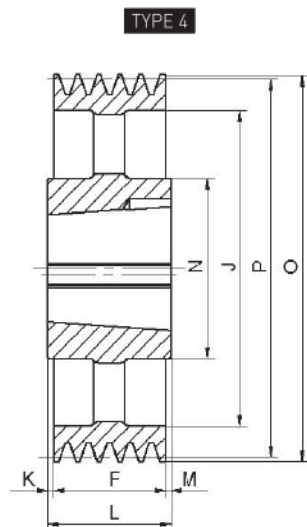

P.M SPA/05

Product Model	Grooves	P	O	TYPE	BUSH	MAX Bore	E	F	J	K	L	M	N	Weight (Kg)
SPA450-05	5	450	455.5	4	3535	90	—	80	415	4.5	89	4.5	175	25.28
SPA475-05	5	475	480.5	4	3535	90	—	80	440	4.5	89	4.5	175	27.70
SPA500-05	5	500	505.5	4	3535	90	—	80	465	4.5	89	4.5	175	29.50
SPA530-05	5	530	535.5	4	3535	90	—	80	495	4.5	89	4.5	175	31.20
SPA560-05	5	560	565.5	4	3535	90	—	80	525	4.5	89	4.5	175	33.50
SPA630-05	5	630	635.5	4	3535	90	—	80	595	4.5	89	4.5	175	37.04
SPA745-05	5	745	750.5	4	4040	100	—	80	710	11	102	11	210	46.70
SPA800-05	5	800	805.5	4	4040	100	—	80	765	11	102	11	210	50.00
SPA900-05	5	900	905.5	4	4040	100	—	80	865	11	102	11	210	64.00
SPA1000-05	5	1000	1005.5	4	4545	110	—	80	965	17	114	17	242	77.20

P.M SPA/06

P.M SPA(P.14-P.24)

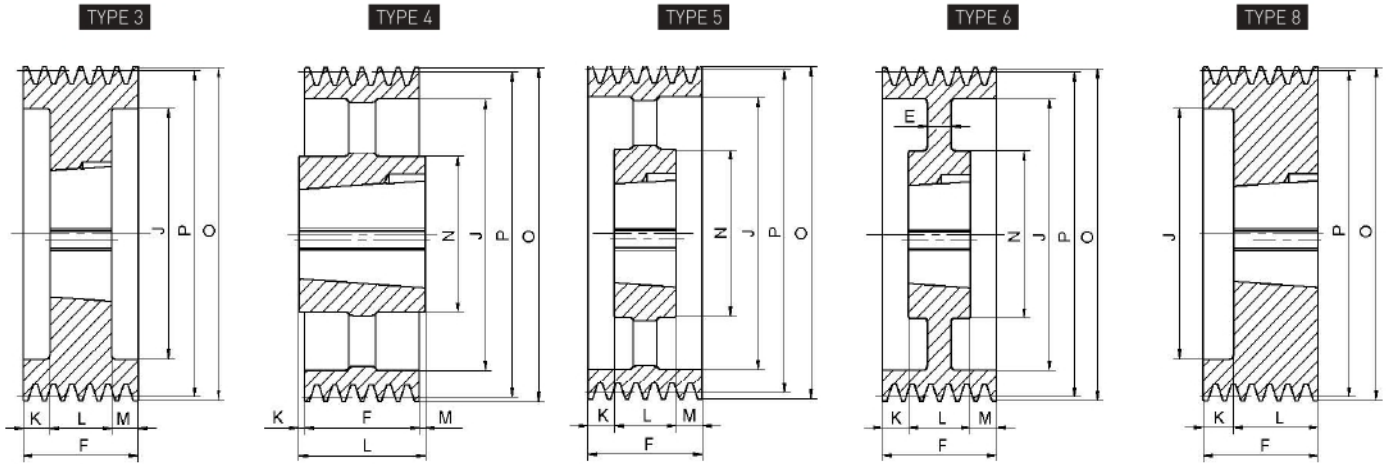

P.M SPA/06

Product Model	Grooves	P	O	TYPE	BUSH	MAX Bore	E	F	J	K	L	M	N	Weight (Kg)
SPA100-06	6	100	105.5	3	1610	42	—	95	66	30	25	40	—	2.41
SPA106-06	6	106	111.5	8	2012	50	—	95	72	63	32	—	—	2.30
SPA112-06	6	112	117.5	8	2012	50	—	95	78	63	32	—	—	2.68
SPA118-06	6	118	123.5	8	2012	50	—	95	84	63	32	—	—	3.15
SPA125-06	6	125	130.5	3	2012	50	—	95	91	31.5	32	31.5	—	3.50
SPA132-06	6	132	137.5	3	2517	60	—	95	98	25	45	25	—	3.74
SPA140-06	6	140	145.5	3	2517	60	—	95	106	25	45	25	—	4.32
SPA145-06	6	145	150.5	3	2517	60	—	95	111	25	45	25	—	4.75
SPA150-06	6	150	155.5	3	2517	60	—	95	116	25	45	25	—	5.20
SPA160-06	6	160	165.5	3	2517	60	—	95	125	25	45	25	—	6.15
SPA170-06	6	170	175.5	3	3020	75	—	95	135	22	51	22	—	6.30
SPA180-06	6	180	185.5	3	3020	75	—	95	146	22	51	22	—	7.20
SPA190-06	6	190	195.5	3	3020	75	—	95	155	22	51	22	—	8.50
SPA200-06	6	200	205.5	3	3020	75	—	95	165	22	51	22	—	9.75
SPA212-06	6	212	217.5	3	3020	75	—	95	177	22	51	22	—	11.20
SPA224-06	6	224	229.5	3	3020	75	—	95	189	22	51	22	—	12.80
SPA236-06	6	236	241.5	3	3020	75	—	95	202	22	51	22	—	14.49
SPA250-06	6	250	255.5	6	3020	75	20	95	215	22	51	22	155	12.60
SPA265-06	6	265	270.5	6	3535	90	25	95	230	3	89	3	175	18.20
SPA280-06	6	280	285.5	5	3535	90	—	95	245	3	89	3	175	18.40
SPA300-06	6	300	305.5	5	3535	90	—	95	265	3	89	3	175	18.72
SPA315-06	6	315	320.5	5	3535	90	—	95	280	3	89	3	175	19.35
SPA335-06	6	335	340.5	5	3535	90	—	95	300	3	89	3	175	20.95
SPA355-06	6	355	360.5	5	3535	90	—	95	320	3	89	3	175	22.30
SPA375-06	6	375	380.5	5	3535	90	—	95	340	3	89	3	175	23.55
SPA400-06	6	400	405.5	5	3535	90	—	95	365	3	89	3	175	24.70
SPA425-06	6	425	430.5	5	3535	90	—	95	390	3	89	3	175	26.20
SPA450-06	6	450	455.5	5	3535	90	—	95	415	3	89	3	175	27.15
SPA500-06	6	500	505.5	5	3535	90	—	95	465	3	89	3	175	28.75
SPA560-06	6	560	565.5	5	3535	90	—	95	525	3	89	3	175	35.00
SPA630-06	6	630	635.5	4	4040	100	—	95	595	3.5	102	3.5	210	48.10
SPA800-06	6	800	805.5	4	4040	100	—	95	765	3.5	102	3.5	210	60.50
SPA900-06	6	900	905.5	4	4040	100	—	95	865	3.5	102	3.5	210	65.70
SPA1000-06	6	1000	1005.5	4	4545	110	—	95	965	9.5	114	9.5	242	76.00

P.M SPB/01

P.M SPB(P.25-P.37)

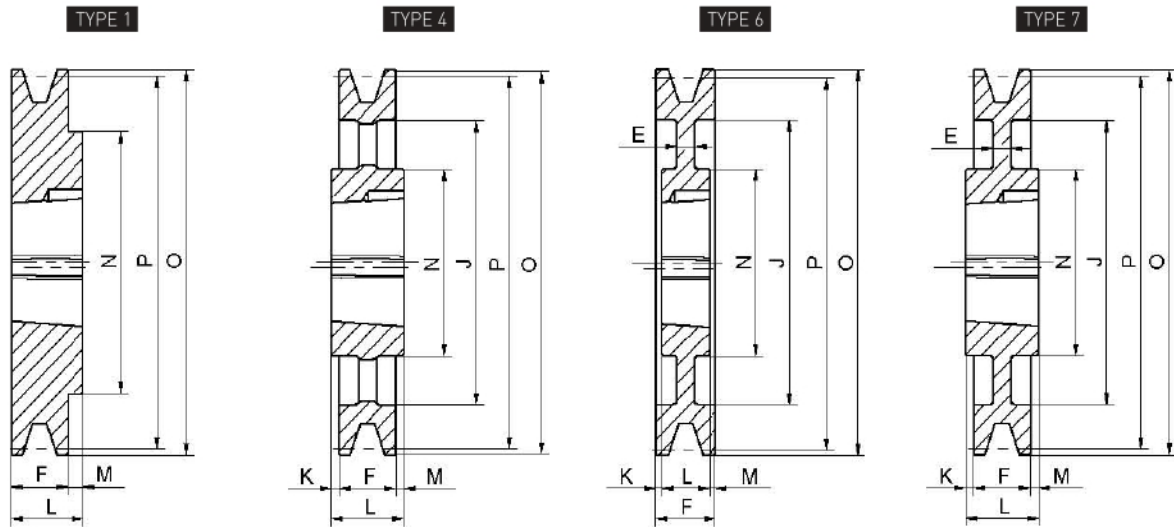

P.M SPB/01

Product Model	Grooves	P	O	TYPE	BUSH	MAX Bore	E	F	J	K	L	M	N	Weight (Kg)
SPB75-01	1	75	82	1	1108	28	—	25	—	—	25	—	—	0.48
SPB80-01	1	80	87	1	1108	28	—	25	—	—	25	—	—	0.55
SPB85-01	1	85	92	1	1210	32	—	25	—	—	25	—	—	0.54
SPB90-01	1	90	97	1	1210	32	—	25	—	—	25	—	—	0.65
SPB95-01	1	95	102	1	1210	32	—	25	—	—	25	—	—	0.76
SPB100-01	1	100	107	1	1610	42	—	25	—	—	25	—	—	0.76
SPB106-01	1	106	113	1	1610	42	—	25	—	—	25	—	—	0.90
SPB112-01	1	112	119	1	1610	42	—	25	—	—	25	—	—	1.10
SPB118-01	1	118	125	1	1610	42	—	25	—	—	25	—	—	1.25
SPB125-01	1	125	132	1	1610	42	—	25	—	—	25	—	—	1.50
SPB132-01	1	132	139	1	1610	42	—	25	—	—	25	—	—	1.70
SPB140-01	1	140	147	1	1610	42	—	25	—	—	25	—	—	2.00
SPB150-01	1	150	157	1	1610	42	—	25	—	—	25	—	—	2.40
SPB160-01	1	160	167	1	1610	42	—	25	—	—	25	—	—	2.80
SPB170-01	1	170	177	1	1610	42	—	25	—	—	25	—	—	3.20
SPB180-01	1	180	187	6	1610	42	12	25	132	—	25	—	90	3.03
SPB190-01	1	190	197	7	2012	50	12	25	147	3.5	32	3.5	104	3.45
SPB200-01	1	200	207	4	2012	50	—	25	157	3.5	32	3.5	104	3.52
SPB212-01	1	212	219	4	2012	50	—	25	169	3.5	32	3.5	104	3.75
SPB224-01	1	224	231	4	2012	50	—	25	181	3.5	32	3.5	104	4.00
SPB236-01	1	236	243	4	2012	50	—	25	193	3.5	32	3.5	104	4.10
SPB250-01	1	250	257	4	2012	50	—	25	207	3.5	32	3.5	104	4.45
SPB265-01	1	265	272	4	2012	50	—	25	222	3.5	32	3.5	104	4.70
SPB280-01	1	280	287	4	2012	50	—	25	237	3.5	32	3.5	104	5.17
SPB300-01	1	300	307	4	2012	50	—	25	258	3.5	32	3.5	104	5.45
SPB315-01	1	315	322	4	2012	50	—	25	272	3.5	32	3.5	104	6.05
SPB335-01	1	335	342	4	2517	60	—	25	292	10	45	10	124	7.84
SPB355-01	1	355	362	4	3020	75	—	25	312	13	51	13	150	8.90
SPB375-01	1	375	382	4	3020	75	—	25	332	13	51	13	150	10.00
SPB400-01	1	400	407	4	3020	75	—	25	357	13	51	13	150	10.22
SPB425-01	1	425	432	4	3020	75	—	25	382	13	51	13	150	11.00
SPB450-01	1	450	457	4	3020	75	—	25	407	13	51	13	150	12.00
SPB475-01	1	475	482	4	3020	75	—	25	432	13	51	13	150	12.50
SPB500-01	1	500	507	4	3020	75	—	25	457	13	51	13	150	13.00
SPB530-01	1	530	537	4	3020	75	—	25	487	13	51	13	150	15.10

P.M SPB/02

P.M SPB(P.25-P.37)

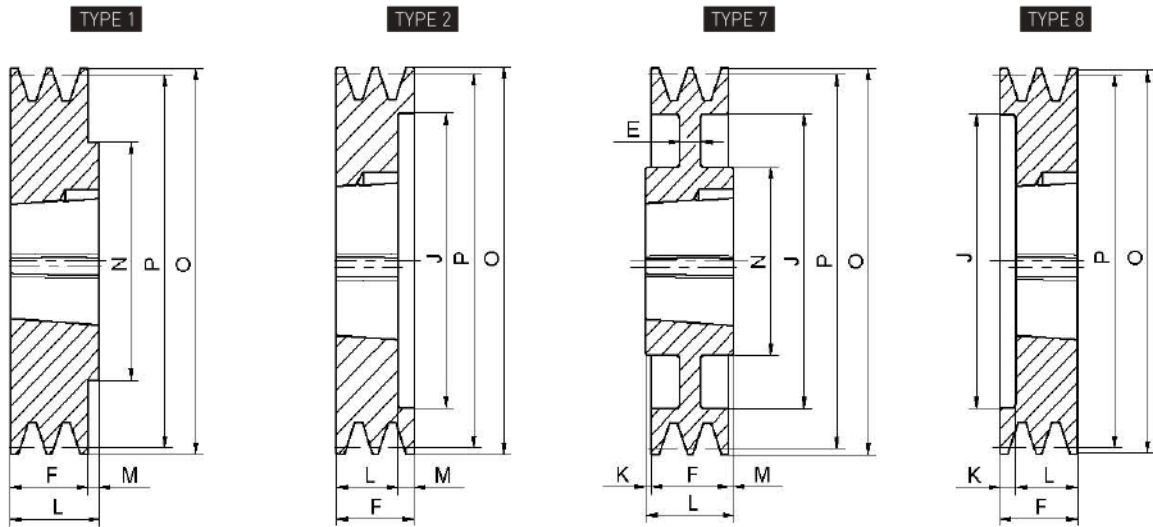

P.M SPB/02

Product Model	Grooves	P	O	TYPE	BUSH	MAX Bore	E	F	J	K	L	M	N	Weight (Kg)
SPB71-02	2	71	78	8	1008	25	—	44	33	22	22	—	—	0.68
SPB75-02	2	75	82	8	1108	28	—	44	37	22	22	—	—	0.74
SPB80-02	2	80	87	8	1108	28	—	44	42	22	22	—	—	0.86
SPB85-02	2	85	92	8	1210	32	—	44	47	19	25	—	—	0.87
SPB90-02	2	90	97	8	1210	32	—	44	52	19	25	—	—	0.92
SPB95-02	2	95	102	8	1610	42	—	44	57	19	25	—	—	1.00
SPB100-02	2	100	107	8	1610	42	—	44	62	19	25	—	—	1.16
SPB106-02	2	106	113	8	1610	42	—	44	67	19	25	—	—	1.35
SPB112-02	2	112	119	8	1610	42	—	44	72	19	25	—	—	1.60
SPB118-02	2	118	125	2	1610	42	—	44	78	—	25	19	—	1.83
SPB125-02	2	125	132	2	2012	50	—	44	82	—	32	12	—	2.20
SPB132-02	2	132	139	2	2012	50	—	44	89	—	32	12	—	2.33
SPB140-02	2	140	147	2	2012	50	—	44	97	—	32	12	—	2.71
SPB145-02	2	145	152	2	2012	50	—	44	102	—	32	12	—	2.95
SPB146-02	2	146	153	2	2012	50	—	44	103	—	32	12	—	3.03
SPB150-02	2	150	157	2	2012	50	—	44	107	—	32	12	—	3.25
SPB155-02	2	155	162	2	2012	50	—	44	112	—	32	12	—	3.50
SPB160-02	2	160	167	2	2012	50	—	44	117	—	32	12	—	3.80
SPB165-02	2	165	172	2	2012	50	—	44	122	—	32	12	—	4.06
SPB170-02	2	170	177	2	2012	50	—	44	127	—	32	12	—	4.40
SPB175-02	2	175	182	2	2012	50	—	44	132	—	32	12	—	4.60
SPB180-02	2	180	187	1	2517	60	—	44	—	—	45	1	120	5.45
SPB185-02	2	185	192	1	2517	60	—	44	—	—	45	1	120	5.85
SPB190-02	2	190	197	1	2517	60	—	44	—	—	45	1	120	6.30
SPB195-02	2	195	202	1	2517	60	—	44	—	—	45	1	120	6.80
SPB200-02	2	200	207	1	2517	60	—	44	—	—	45	1	117	7.30
SPB206-02	2	206	213	7	2517	60	15	44	163	—	45	1	117	5.78
SPB210-02	2	210	217	7	2517	60	15	44	167	—	45	1	117	6.00
SPB212-02	2	212	219	7	2517	60	15	44	169	—	45	1	117	6.05
SPB215-02	2	215	222	7	2517	60	15	44	172	—	45	1	117	6.18
SPB218-02	2	218	225	7	2517	60	15	44	175	—	45	1	117	6.35

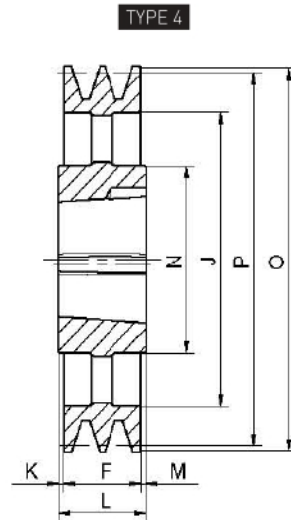

P.M SPB/02

Product Model	Grooves	P	O	TYPE	BUSH	MAX Bore	E	F	J	K	L	M	N	Weight (Kg)
SPB224-02	2	224	231	4	2517	60	—	44	181	—	45	1	117	5.84
SPB230-02	2	230	237	4	2517	60	—	44	187	—	45	1	117	6.15
SPB236-02	2	236	243	4	2517	60	—	44	193	—	45	1	117	6.28
SPB243-02	2	243	250	4	2517	60	—	44	200	—	45	1	117	6.50
SPB250-02	2	250	257	4	2517	60	—	44	207	—	45	1	125	7.00
SPB258-02	2	258	265	4	2517	60	—	44	215	—	45	1	125	7.45
SPB265-02	2	265	272	4	2517	60	—	44	222	—	45	1	125	7.50
SPB273-02	2	273	280	4	2517	60	—	44	230	—	45	1	125	7.95
SPB280-02	2	280	287	4	2517	60	—	44	237	—	45	1	125	8.06
SPB290-02	2	290	297	4	2517	60	—	44	247	—	45	1	125	8.30
SPB300-02	2	300	307	4	2517	60	—	44	257	—	45	1	125	8.67
SPB305-02	2	305	312	4	2517	60	—	44	262	—	45	1	125	8.70
SPB310-02	2	310	317	4	2517	60	—	44	267	—	45	1	125	8.85
SPB315-02	2	315	322	4	2517	60	—	44	272	—	45	1	125	9.15
SPB325-02	2	325	332	4	2517	60	—	44	282	—	45	1	125	9.45
SPB335-02	2	335	342	4	2517	60	—	44	292	—	45	1	125	9.82
SPB345-02	2	345	352	4	2517	60	—	44	302	—	45	—	125	10.15
SPB355-02	2	355	362	4	3020	75	—	44	312	3.5	51	3.5	144	10.98
SPB375-02	2	375	382	4	3020	75	—	44	332	3.5	51	3.5	144	11.45
SPB400-02	2	400	407	4	3020	75	—	44	357	3.5	51	3.5	150	13.60
SPB425-02	2	425	432	4	3020	75	—	44	382	3.5	51	3.5	150	14.30
SPB450-02	2	450	457	4	3020	75	—	44	407	3.5	51	3.5	150	15.20
SPB475-02	2	475	482	4	3020	75	—	44	432	3.5	51	3.5	150	17.05
SPB500-02	2	500	507	4	3020	75	—	44	457	3.5	51	3.5	150	17.14
SPB530-02	2	530	537	4	3020	75	—	44	487	3.5	51	3.5	150	17.82
SPB560-02	2	560	567	4	3030	75	—	44	517	4	76	28	150	21.55
SPB630-02	2	630	637	4	3030	75	—	44	587	16	76	16	150	24.70
SPB710-02	2	710	717	4	3030	75	—	44	664	16	76	16	150	30.45
SPB800-02	2	800	807	4	3030	75	—	44	754	16	76	16	150	34.40

P.M SPB/03

P.M SPB(P.25-P.37)

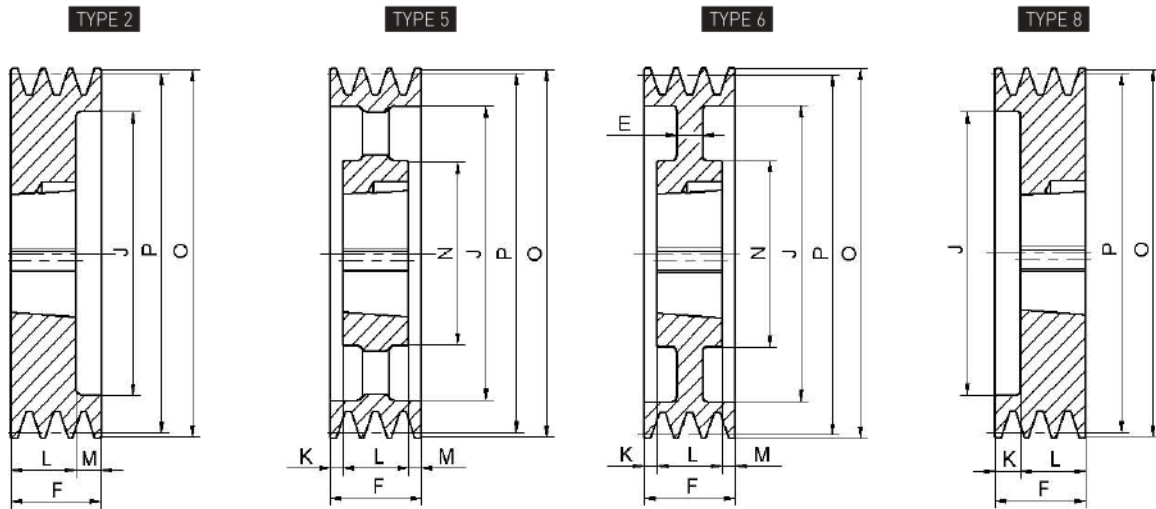

P.M SPB/03

Product Model	Grooves	P	O	TYPE	BUSH	MAX Bore	E	F	J	K	L	M	N	Weight (Kg)
SPB71-03	3	71	78	8	1008	25	—	63	33	41	22	—	—	0.95
SPB75-03	3	75	82	8	1108	28	—	63	37	41	22	—	—	1.02
SPB80-03	3	80	87	8	1108	28	—	63	40	41	22	—	—	1.20
SPB85-03	3	85	92	8	1210	32	—	63	45	38	25	—	—	1.26
SPB90-03	3	90	97	8	1210	32	—	63	50	38	25	—	—	1.40
SPB95-03	3	95	102	8	1210	32	—	63	55	38	25	—	—	1.58
SPB100-03	3	100	107	8	1610	42	—	63	62	38	25	—	—	1.65
SPB106-03	3	106	113	8	1610	42	—	63	67	38	25	—	—	1.80
SPB112-03	3	112	119	8	1610	42	—	63	72	38	25	—	—	2.08
SPB118-03	3	118	125	2	1610	42	—	63	78	—	25	38	—	2.35
SPB125-03	3	125	132	2	2012	50	—	63	82	—	32	31	—	2.60
SPB132-03	3	132	139	2	2012	50	—	63	89	—	32	31	—	3.00
SPB140-03	3	140	147	2	2012	50	—	63	97	—	32	31	—	3.45
SPB145-03	3	145	152	2	2012	50	—	63	102	—	32	31	—	3.75
SPB150-03	3	150	157	2	2517	60	—	63	107	—	45	18	—	3.90
SPB155-03	3	155	162	2	2517	60	—	63	112	—	45	18	—	4.29
SPB160-03	3	160	167	2	2517	60	—	63	117	—	45	18	—	4.72
SPB165-03	3	165	172	2	2517	60	—	63	122	—	45	18	—	5.16
SPB170-03	3	170	177	2	2517	60	—	63	127	—	45	18	—	5.55
SPB175-03	3	175	182	2	2517	60	—	63	132	—	45	18	—	6.03
SPB180-03	3	180	187	2	2517	60	—	63	137	—	45	18	—	6.42
SPB185-03	3	185	192	2	2517	60	—	63	142	—	45	18	—	6.90
SPB190-03	3	190	197	2	2517	60	—	63	147	—	45	18	—	7.37
SPB195-03	3	195	202	2	2517	60	—	63	152	—	45	18	—	8.07
SPB200-03	3	200	207	2	2517	60	—	63	157	—	45	18	—	8.55
SPB206-03	3	206	213	6	2517	60	15	63	163	—	45	18	117	6.95
SPB210-03	3	210	217	6	2517	60	15	63	167	—	45	18	117	7.15
SPB212-03	3	212	219	6	2517	60	15	63	169	—	45	18	117	7.37
SPB215-03	3	215	222	6	2517	60	15	63	172	—	45	18	117	7.50
SPB218-03	3	218	225	6	2517	60	15	63	175	—	45	18	117	7.55
SPB224-03	3	224	231	5	2517	60	—	63	181	—	45	18	117	7.47
SPB230-03	3	230	237	5	2517	60	—	63	187	—	45	18	117	7.94
SPB236-03	3	236	243	5	2517	60	—	63	193	—	45	18	117	7.95

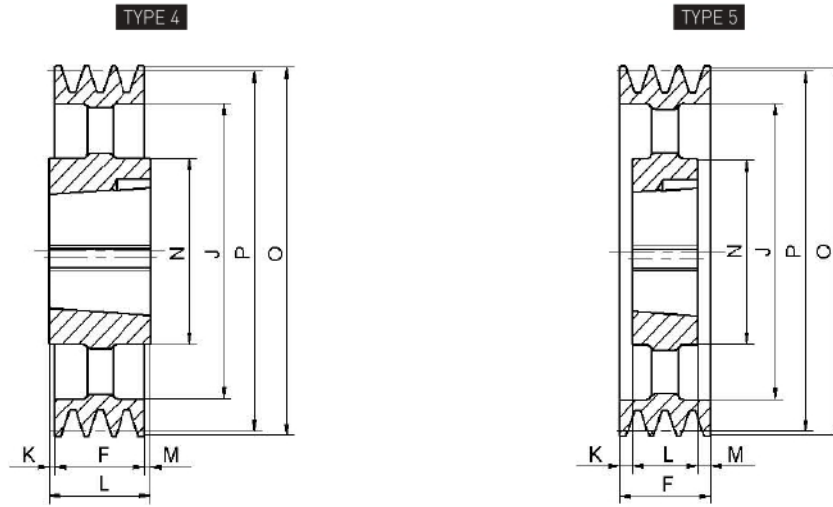

P.M SPB/03

Product Model	Grooves	P	O	TYPE	BUSH	MAX Bore	E	F	J	K	L	M	N	Weight (Kg)
SPB240-03	3	240	247	5	2517	60	—	63	197	—	45	18	117	8.10
SPB243-03	3	243	250	5	2517	60	—	63	200	—	45	18	117	8.40
SPB250-03	3	250	257	5	3020	75	—	63	207	—	51	12	144	9.53
SPB258-03	3	258	265	5	3020	75	—	63	215	—	51	12	144	9.80
SPB260-03	3	260	267	5	3020	75	—	63	217	—	51	12	144	9.85
SPB265-03	3	265	272	5	3020	75	—	63	222	—	51	12	144	10.25
SPB273-03	3	273	280	5	3020	75	—	63	230	6	51	6	144	10.57
SPB280-03	3	280	287	5	3020	75	—	63	237	6	51	6	144	10.86
SPB290-03	3	290	297	5	3020	75	—	63	247	6	51	6	144	11.34
SPB300-03	3	300	307	5	3020	75	—	63	257	6	51	6	144	11.45
SPB305-03	3	305	312	5	3020	75	—	63	262	6	51	6	144	11.90
SPB310-03	3	310	317	5	3020	75	—	63	267	6	51	6	144	12.10
SPB315-03	3	315	322	5	3020	75	—	63	272	6	51	6	144	12.25
SPB325-03	3	325	332	5	3020	75	—	63	282	6	51	6	144	12.80
SPB335-03	3	335	342	5	3020	75	—	63	292	6	51	6	144	12.75
SPB345-03	3	345	352	5	3020	75	—	63	302	6	51	6	144	13.60
SPB355-03	3	355	362	5	3020	75	—	63	312	6	51	6	144	14.45
SPB375-03	3	375	382	4	3535	90	—	63	332	13	89	13	175	20.17
SPB400-03	3	400	407	4	3535	90	—	63	357	13	89	13	175	20.95
SPB425-03	3	425	432	4	3535	90	—	63	382	—	89	26	175	23.07
SPB450-03	3	450	457	4	3535	90	—	63	407	—	89	26	175	24.50
SPB475-03	3	475	482	4	3535	90	—	63	432	—	89	26	175	25.20
SPB500-03	3	500	507	4	3535	90	—	63	457	—	89	26	175	27.50
SPB530-03	3	530	537	4	3535	90	—	63	487	—	89	26	175	29.00
SPB560-03	3	560	567	4	3535	90	—	63	517	—	89	26	175	29.32
SPB600-03	3	600	607	4	3535	90	—	63	557	—	89	26	175	35.00
SPB630-03	3	630	637	4	3535	90	—	63	587	—	89	26	175	35.10
SPB710-03	3	710	717	4	3535	90	—	63	664	13	89	13	175	42.30
SPB800-03	3	800	807	4	3535	90	—	63	754	13	89	13	175	48.75
SPB900-03	3	900	907	4	3535	90	—	63	854	13	89	13	175	55.50
SPB1000-03	3	1000	1007	4	4040	100	—	63	954	19.5	102	19.5	210	76.40
SPB1120-03	3	1120	1127	4	4040	100	—	63	1074	19.5	102	19.5	210	71.00
SPB1250-03	3	1250	1257	4	4040	100	—	63	1204	19.5	102	19.5	210	102.00

P.M SPB/04

P.M SPB(P.25-P.37)

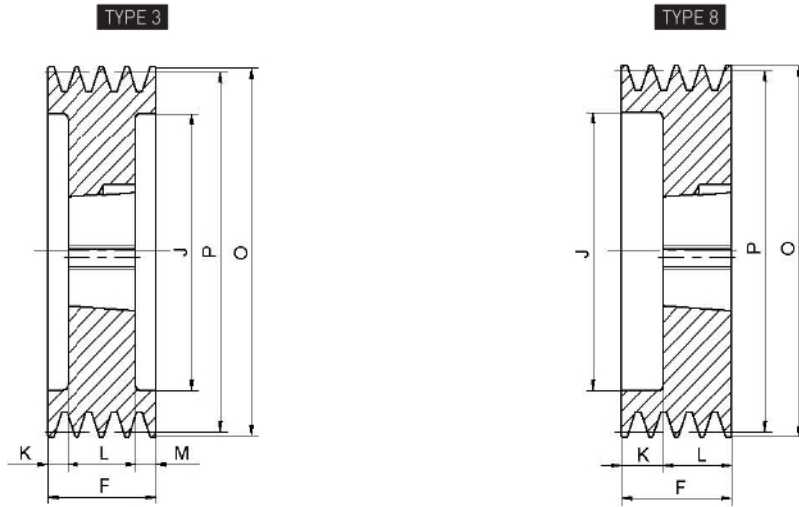

P.M SPB/04

Product Model	Grooves	P	O	TYPE	BUSH	MAX Bore	E	F	J	K	L	M	N	Weight (Kg)
SPB75-04	4	75	82	8	1108	28	—	82	37	60	22	—	—	1.30
SPB90-04	4	90	97	8	1210	32	—	82	50	57	25	—	—	1.82
SPB95-04	4	95	102	8	1610	42	—	82	55	57	25	—	—	1.89
SPB100-04	4	100	107	8	1610	42	—	82	60	57	25	—	—	2.08
SPB106-04	4	106	113	8	1610	42	—	82	66	57	25	—	—	2.30
SPB112-04	4	112	119	8	2012	42	—	82	72	50	32	—	—	2.40
SPB118-04	4	118	125	8	1610	42	—	82	78	57	25	—	—	2.86
SPB125-04	4	125	132	3	2012	50	—	82	82	25	32	25	—	3.27
SPB132-04	4	132	139	3	2012	50	—	82	89	25	32	25	—	3.65
SPB140-04	4	140	147	3	2517	60	—	82	100	18.5	45	18.5	—	3.76
SPB150-04	4	150	157	3	2517	60	—	82	107	18.5	45	18.5	—	4.70
SPB155-04	4	155	162	3	2517	60	—	82	112	18.5	45	18.5	—	5.10
SPB160-04	4	160	167	3	2517	60	—	82	117	18.5	45	18.5	—	5.55
SPB165-04	4	165	172	3	2517	60	—	82	122	18.5	45	18.5	—	5.97
SPB170-04	4	170	177	3	2517	60	—	82	127	18.5	45	18.5	—	6.48
SPB175-04	4	175	182	3	2517	60	—	82	132	18.5	45	18.5	—	6.95
SPB180-04	4	180	187	3	2517	60	—	82	137	18.5	45	18.5	—	7.40
SPB185-04	4	185	192	3	2517	60	—	82	142	18.5	45	18.5	—	8.00
SPB190-04	4	190	197	3	2517	60	—	82	147	18.5	45	18.5	—	8.40
SPB195-04	4	195	202	3	3020	75	—	82	152	15.5	51	15.5	—	8.40
SPB200-04	4	200	207	3	3020	75	—	82	157	15.5	51	15.5	—	9.14
SPB206-04	4	206	213	3	3020	75	—	82	163	15.5	51	15.5	—	9.90
SPB210-04	4	210	217	3	3020	75	—	82	167	15.5	51	15.5	—	10.30
SPB212-04	4	212	219	3	3020	75	—	82	169	15.5	51	15.5	—	10.60
SPB215-04	4	215	222	3	3020	75	—	82	172	15.5	51	15.5	—	11.10
SPB218-04	4	218	225	3	3020	75	—	82	175	15.5	51	15.5	—	11.38
SPB224-04	4	224	231	3	3020	75	—	82	181	15.5	51	15.5	—	12.10
SPB225-04	4	225	232	3	3020	75	—	82	182	15.5	51	15.5	—	12.56
SPB230-04	4	230	237	3	3020	75	—	82	187	15.5	51	15.5	—	12.99
SPB236-04	4	236	243	3	3020	75	—	82	193	15.5	51	15.5	—	13.80
SPB240-04	4	240	247	3	3020	75	—	82	197	15.5	51	15.5	—	14.30
SPB243-04	4	243	250	3	3020	75	—	82	200	15.5	51	15.5	—	14.90

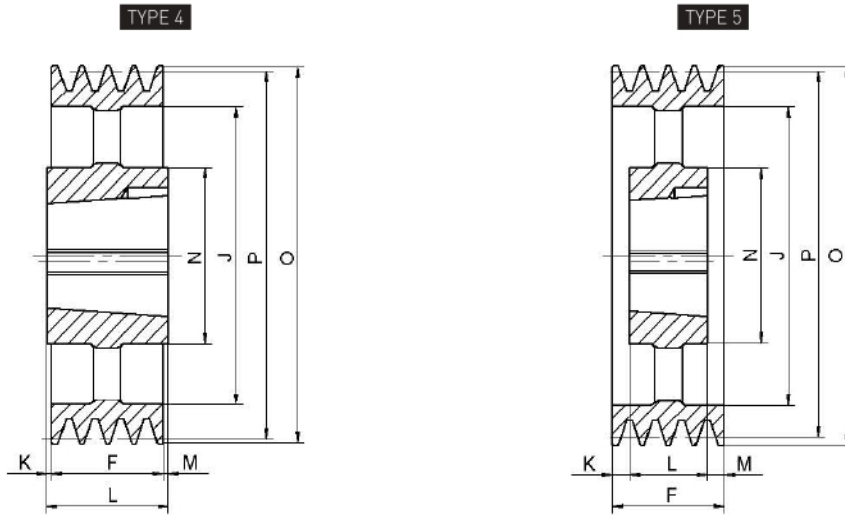

P.M SPB/04

Product Model	Grooves	P	O	TYPE	BUSH	MAX Bore	E	F	J	K	L	M	N	Weight (Kg)
SPB250-04	4	250	257	5	3020	75	—	82	207	15.5	51	15.5	144	11.20
SPB258-04	4	258	265	5	3020	75	—	82	215	15.5	51	15.5	144	12.00
SPB265-04	4	265	272	5	3020	75	—	82	222	15.5	51	15.5	144	12.20
SPB273-04	4	273	280	5	3020	75	—	82	230	15.5	51	15.5	144	12.42
SPB280-04	4	280	287	5	3020	75	—	82	237	15.5	51	15.5	144	12.95
SPB290-04	4	290	297	5	3020	75	—	82	247	15.5	51	15.5	144	13.32
SPB300-04	4	300	307	4	3535	90	—	82	257	—	89	7.0	175	18.25
SPB315-04	4	315	322	4	3535	90	—	82	272	3.5	89	3.5	175	19.25
SPB325-04	4	325	332	4	3535	90	—	82	282	3.5	89	3.5	175	20.10
SPB335-04	4	335	342	4	3535	90	—	82	292	3.5	89	3.5	175	20.75
SPB345-04	4	345	352	4	3535	90	—	82	302	3.5	89	3.5	175	21.20
SPB355-04	4	355	362	4	3535	90	—	82	312	3.5	89	3.5	175	21.62
SPB375-04	4	375	382	4	3535	90	—	82	332	3.5	89	3.5	175	23.05
SPB400-04	4	400	407	4	3535	90	—	82	357	3.5	89	3.5	175	24.76
SPB425-04	4	425	432	4	3535	90	—	82	382	—	89	7	175	26.26
SPB450-04	4	450	457	4	3535	90	—	82	407	—	89	7	175	27.83
SPB475-04	4	475	482	4	3535	90	—	82	432	—	89	7	175	29.74
SPB500-04	4	500	507	4	3535	90	—	82	457	—	89	7	175	30.84
SPB530-04	4	530	537	4	3535	90	—	82	487	—	89	7	175	31.00
SPB560-04	4	560	567	4	3535	90	—	82	517	—	89	7	175	36.05
SPB600-04	4	600	607	4	3535	90	—	82	557	—	89	7	175	40.10
SPB630-04	4	630	637	4	3535	90	—	82	587	—	89	7	175	40.12
SPB710-04	4	710	717	4	3535	90	—	82	664	3.5	89	3.5	175	47.50
SPB800-04	4	800	807	4	4040	100	—	82	754	10	102	10	210	63.40
SPB900-04	4	900	907	4	4040	100	—	82	854	10	102	10	210	75.00
SPB1000-04	4	1000	1007	4	4040	100	—	82	954	10	102	10	210	86.15
SPB1120-04	4	1120	1127	4	4040	100	—	82	1074	10	102	10	210	98.80
SPB1250-04	4	1250	1257	4	4545	110	—	82	1204	16	114	16	242	116.00

P.M SPB/05

P.M SPB(P.25-P.37)

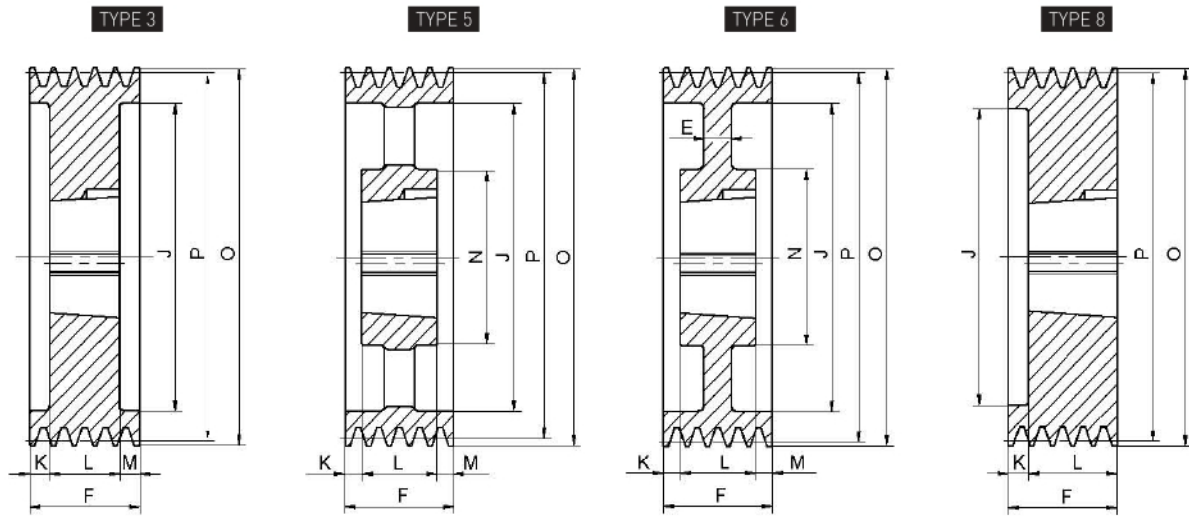

P.M SPB/05

Product Model	Grooves	P	O	TYPE	BUSH	MAX Bore	E	F	J	K	L	M	N	Weight (Kg)
SPB90-05	5	90	97	8	1215	32	—	101	50	63	38	—	—	2.50
SPB100-05	5	100	107	8	1615	42	—	101	60	63	38	—	—	2.80
SPB106-05	5	106	113	8	1615	42	—	101	66	63	38	—	—	3.00
SPB112-05	5	112	119	8	1615	42	—	101	72	63	38	—	—	3.32
SPB118-05	5	118	125	8	1615	42	—	101	78	63	38	—	—	3.88
SPB125-05	5	125	132	8	2012	50	—	101	87	69	32	—	—	3.55
SPB132-05	5	132	139	8	2517	60	—	101	94	56	45	—	—	3.65
SPB140-05	5	140	147	3	2517	60	—	101	97	28	45	28	—	4.60
SPB150-05	5	150	157	3	2517	60	—	101	107	28	45	28	—	5.50
SPB160-05	5	160	167	3	2517	60	—	101	117	28	45	28	—	6.45
SPB170-05	5	170	177	3	3020	75	—	101	127	25	51	25	—	6.53
SPB180-05	5	180	187	3	3020	75	—	101	137	25	51	25	—	7.55
SPB190-05	5	190	197	3	3020	75	—	101	147	25	51	25	—	8.81
SPB200-05	5	200	207	3	3020	75	—	101	157	25	51	25	—	10.25
SPB206-05	5	206	213	3	3020	75	—	101	163	25	51	25	—	10.96
SPB212-05	5	212	219	3	3020	75	—	101	169	25	51	25	—	11.80
SPB224-05	5	224	231	3	3020	75	—	101	181	25	51	25	—	13.50
SPB236-05	5	236	243	3	3535	90	—	101	193	6	89	6	—	19.08
SPB250-05	5	250	257	3	3535	90	—	101	207	6	89	6	—	20.32
SPB265-05	5	265	272	6	3535	90	30	101	222	6	89	6	175	21.77
SPB280-05	5	280	287	6	3535	90	25	101	237	6	89	6	175	20.90
SPB300-05	5	300	307	5	3535	90	—	101	257	6	89	6	175	19.45
SPB315-05	5	315	322	5	3535	90	—	101	272	6	89	6	175	20.20
SPB335-05	5	335	342	5	3535	90	—	101	292	6	89	6	175	22.70
SPB355-05	5	355	362	5	3535	90	—	101	312	6	89	6	175	24.30
SPB375-05	5	375	382	5	3535	90	—	101	332	6	89	6	175	24.36
SPB380-05	5	380	387	5	3535	90	—	101	337	6	89	6	175	26.50
SPB400-05	5	400	407	5	3535	90	—	101	357	6	89	6	175	27.78
SPB425-05	5	425	432	5	3535	90	—	101	382	6	89	6	175	29.40
SPB450-05	5	450	457	5	3535	90	—	101	407	—	89	12	175	31.35
SPB475-05	5	475	482	5	3535	90	—	101	432	—	89	12	175	32.69
SPB500-05	5	500	507	5	3535	90	—	101	457	—	89	12	175	35.15

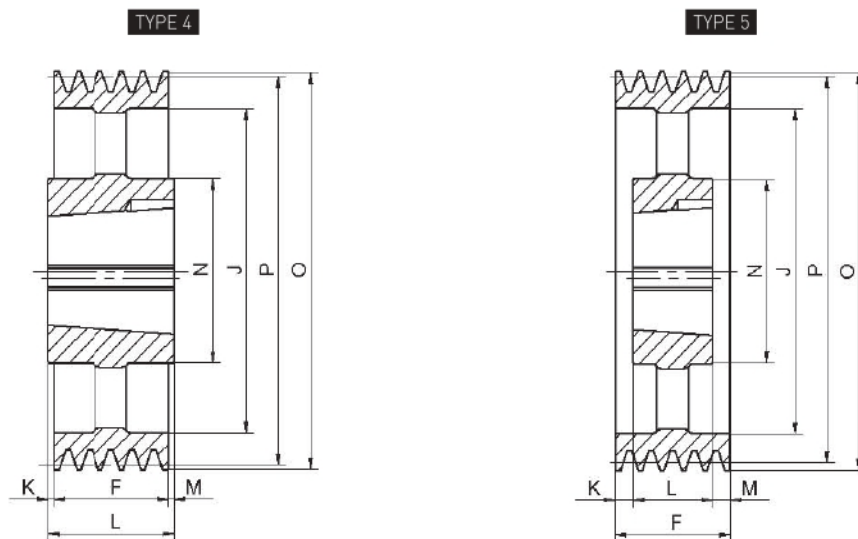

P.M SPB/05

Product Model	Grooves	P	O	TYPE	BUSH	MAX Bore	E	F	J	K	L	M	N	Weight (Kg)
SPB530-05	5	530	537	5	3535	90	—	101	487	—	89	12	175	37.65
SPB560-05	5	560	567	4	4040	100	—	101	517	—	102	1	210	45.30
SPB600-05	5	600	607	4	4040	100	—	101	557	—	102	1	210	47.60
SPB630-05	5	630	637	4	4040	100	—	101	587	—	102	1	210	50.15
SPB710-05	5	710	717	4	4040	100	—	101	664	—	102	1	210	60.20
SPB800-05	5	800	807	4	4040	100	—	101	754	—	102	1	210	68.00
SPB900-05	5	900	907	4	4040	100	—	101	854	—	102	1	210	82.00
SPB1000-05	5	1000	1007	4	4545	110	—	101	954	6.5	114	6.5	242	99.75
SPB1120-05	5	1120	1127	4	4545	110	—	101	1074	6.5	114	6.5	242	101.31
SPB1250-05	5	1250	1257	4	4545	110	—	101	1204	6.5	114	6.5	242	133.20
SPB1400-05	5	1400	1407	4	5040	125	—	101	1354	0.5	102	0.5	267	153.00

P.M SPB/06

P.M SPB(P.25-P.37)

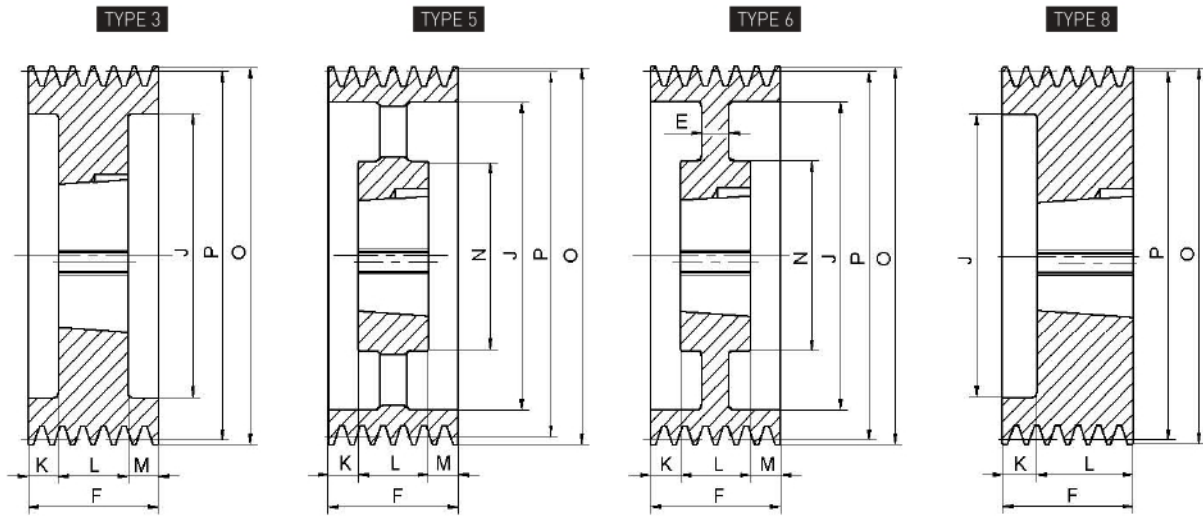

P.M SPB/06

Product Model	Grooves	P	O	TYPE	BUSH	MAX Bore	E	F	J	K	L	M	N	Weight (Kg)
SPB90-06	6	90	97	8	1215	32	—	120	50	82	38	—	—	1.80
SPB100-06	6	100	107	8	1615	42	—	120	60	82	38	—	—	2.57
SPB106-06	6	106	113	3	1615	42	—	120	66	41	38	41	—	3.38
SPB112-06	6	112	119	3	1615	42	—	120	72	41	38	41	—	3.78
SPB118-06	6	118	125	3	1615	42	—	120	78	41	38	41	—	4.22
SPB125-06	6	125	132	3	2012	50	—	120	83	44	32	44	—	4.41
SPB132-06	6	132	139	3	2012	50	—	120	90	44	32	44	—	4.90
SPB140-06	6	140	147	3	2517	60	—	120	100	37.5	45	37.5	—	5.10
SPB150-06	6	150	157	3	2517	60	—	120	107	37.5	45	37.5	—	6.25
SPB160-06	6	160	167	3	3020	75	—	120	119	34.5	51	34.5	—	6.18
SPB170-06	6	170	177	3	3020	75	—	120	127	34.5	51	34.5	—	7.35
SPB180-06	6	180	187	3	3020	75	—	120	137	34.5	51	34.5	—	8.57
SPB190-06	6	190	197	3	3020	75	—	120	147	34.5	51	34.5	—	9.75
SPB200-06	6	200	207	3	3020	75	—	120	157	34.5	51	34.5	—	11.46
SPB212-06	6	212	219	3	3535	90	—	120	169	15.5	89	15.5	—	14.95
SPB224-06	6	224	231	3	3535	90	—	120	181	15.5	89	15.5	—	17.57
SPB236-06	6	236	243	3	3535	90	—	120	193	15.5	89	15.5	—	20.25
SPB250-06	6	250	257	3	3535	90	—	120	207	15.5	89	15.5	—	23.74
SPB260-06	6	260	267	3	3535	90	—	120	217	15.5	89	15.5	—	24.69
SPB265-06	6	265	272	6	3535	90	30	120	222	15.5	89	15.5	175	23.65
SPB280-06	6	280	287	6	3535	90	25	120	237	15.5	89	15.5	175	22.52
SPB300-06	6	300	307	5	3535	90	—	120	257	15.5	89	15.5	175	22.35
SPB315-06	6	315	322	5	3535	90	—	120	272	15.5	89	15.5	175	23.55
SPB335-06	6	335	342	5	3535	90	—	120	292	15.5	89	15.5	175	25.05
SPB355-06	6	355	362	5	3535	90	—	120	312	15.5	89	15.5	175	26.08
SPB375-06	6	375	382	5	3535	90	—	120	332	15.5	89	15.5	175	28.40
SPB400-06	6	400	407	5	3535	90	—	120	357	15.5	89	15.5	175	29.85
SPB425-06	6	425	432	5	3535	90	—	120	382	15.5	89	15.5	175	31.90
SPB450-06	6	450	457	5	4040	100	—	120	407	—	102	18	210	39.30
SPB475-06	6	475	482	5	4040	100	—	120	432	—	102	18	210	40.30
SPB500-06	6	500	507	5	4040	100	—	120	457	—	102	18	210	43.43
SPB530-06	6	530	537	5	4040	100	—	120	487	—	102	18	210	46.15

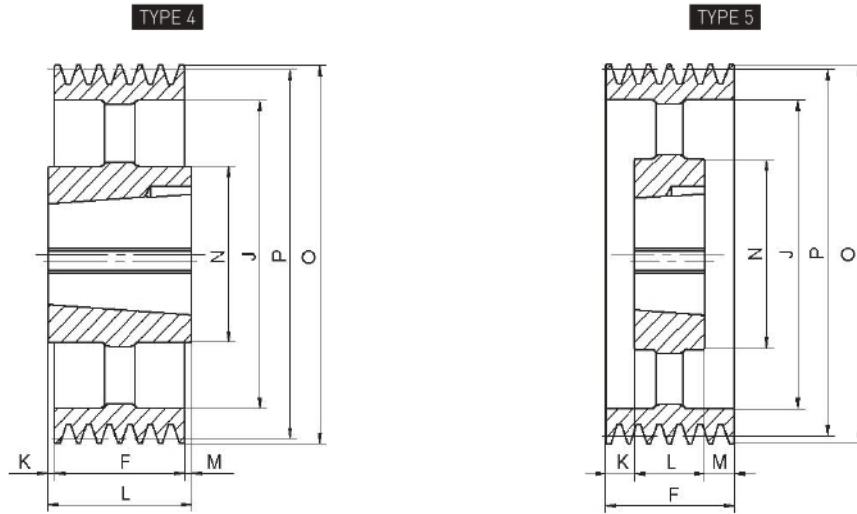

P.M SPB/06

Product Model	Grooves	P	O	TYPE	BUSH	MAX Bore	E	F	J	K	L	M	N	Weight (Kg)
SPB560-06	6	560	567	5	4040	100	—	120	517	—	102	18	210	48.55
SPB630-06	6	630	637	5	4040	100	—	120	587	—	102	18	210	54.70
SPB710-06	6	710	717	5	4040	100	—	120	664	9	102	9	210	65.98
SPB800-06	6	800	807	5	4545	110	—	120	754	3	114	3	242	77.52
SPB900-06	6	900	907	5	4545	110	—	120	854	3	114	3	242	90.10
SPB1000-06	6	1000	1007	5	4545	110	—	120	954	3	114	3	242	111.00
SPB1250-06	6	1250	1257	5	4545	110	—	120	1204	3	114	3	242	144.00
SPB1400-06	6	1400	1407	4	5050	125	—	120	1354	3.5	127	3.5	267	146.07

P.M SPB/08

P.M SPB(P.25-P.37)

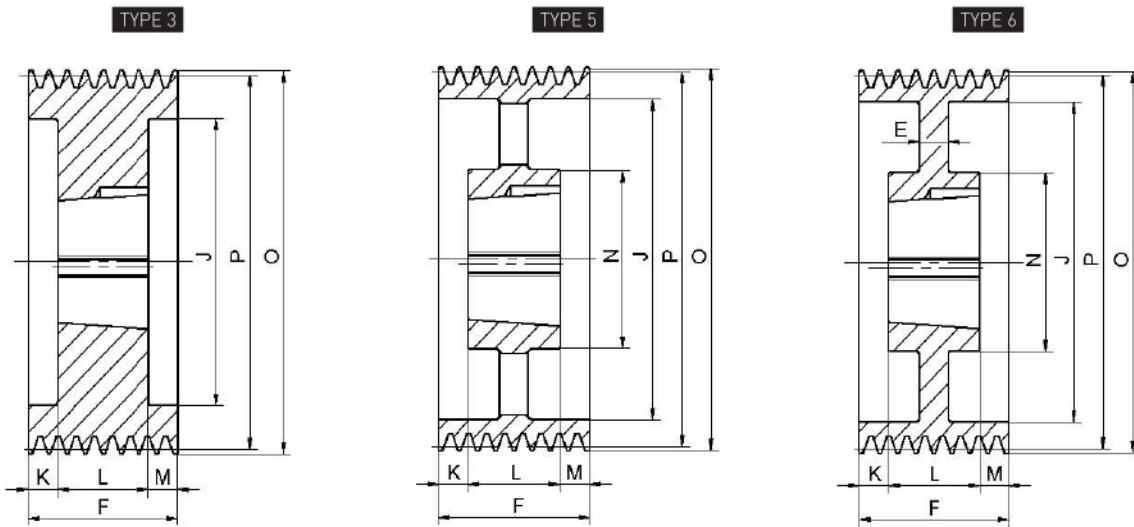

P.M SPB/08

Product Model	Grooves	P	O	TYPE	BUSH	MAX Bore	E	F	J	K	L	M	N	Weight (Kg)
SPB140-08	8	140	147	3	2517	60	—	158	97	56.5	45	56.5	—	6.78
SPB150-08	8	150	157	3	2517	60	—	158	107	56.5	45	56.5	—	7.97
SPB160-08	8	160	167	3	3020	75	—	158	118	53.5	51	53.5	—	7.85
SPB170-08	8	170	177	3	3030	75	—	158	127	41	76	41	—	10.05
SPB180-08	8	180	187	3	3030	75	—	158	137	41	76	41	—	12.00
SPB190-08	8	190	197	3	3030	75	—	158	147	41	76	41	—	13.55
SPB200-08	8	200	207	3	3535	90	—	158	157	34.5	89	34.5	—	14.60
SPB212-08	8	212	219	3	3535	90	—	158	169	34.5	89	34.5	—	17.02
SPB224-08	8	224	231	3	3535	90	—	158	181	34.5	89	34.5	—	20.16
SPB236-08	8	236	243	3	3535	90	—	158	193	34.5	89	34.5	—	22.90
SPB240-08	8	240	247	3	3535	90	—	158	197	34.5	89	34.5	—	24.01
SPB250-08	8	250	257	3	3535	90	—	158	207	34.5	89	34.5	—	26.69
SPB260-08	8	260	267	3	3535	90	—	158	217	34.5	89	34.5	—	29.50
SPB265-08	8	265	272	6	3535	90	25	158	222	34.5	89	34.5	175	24.25
SPB280-08	8	280	287	6	3535	90	25	158	237	34.5	89	34.5	175	25.87
SPB300-08	8	300	307	6	3535	90	25	158	257	34.5	89	34.5	175	28.55
SPB315-08	8	315	322	5	3535	90	—	158	272	34.5	89	34.5	175	28.35
SPB335-08	8	335	342	5	3535	90	—	158	292	34.5	89	34.5	175	31.10
SPB355-08	8	355	362	5	3535	90	—	158	312	34.5	89	34.5	175	31.40
SPB375-08	8	375	382	5	3535	90	—	158	332	34.5	89	34.5	175	33.15
SPB400-08	8	400	407	5	4040	100	—	158	357	28	102	28	210	41.50
SPB425-08	8	425	432	5	4040	100	—	158	382	28	102	28	210	38.12
SPB450-08	8	450	457	5	4040	100	—	158	407	28	102	28	210	46.75
SPB475-08	8	475	482	5	4040	100	—	158	432	28	102	28	210	47.20
SPB500-08	8	500	507	5	4040	100	—	158	457	28	102	28	210	52.35
SPB530-08	8	530	537	5	4040	100	—	158	487	28	102	28	210	53.04
SPB560-08	8	560	567	5	4545	110	—	158	517	22	114	22	242	65.70
SPB630-08	8	630	637	5	4545	110	—	158	587	22	114	22	242	72.06
SPB710-08	8	710	717	5	4545	110	—	158	664	22	114	22	242	83.00
SPB800-08	8	800	807	5	4545	110	—	158	754	22	114	22	242	97.56
SPB900-08	8	900	907	5	4545	110	—	158	854	22	114	22	242	108.00
SPB1000-08	8	1000	1007	5	5050	125	—	158	954	15.5	127	15.5	267	130.00
SPB1120-08	8	1120	1127	5	5050	125	—	158	1074	15.5	127	15.5	267	145.00
SPB1250-08	8	1250	1257	5	5050	125	—	158	1204	15.5	127	15.5	267	161.40
SPB1400-08	8	1400	1407	5	5050	125	—	158	1354	15.5	127	15.5	267	195.00

TAPER BUSHING V-BELT PULLEYS
 ● P.M SPB/08
 ● P.M SPB/10

P.M SPB/10

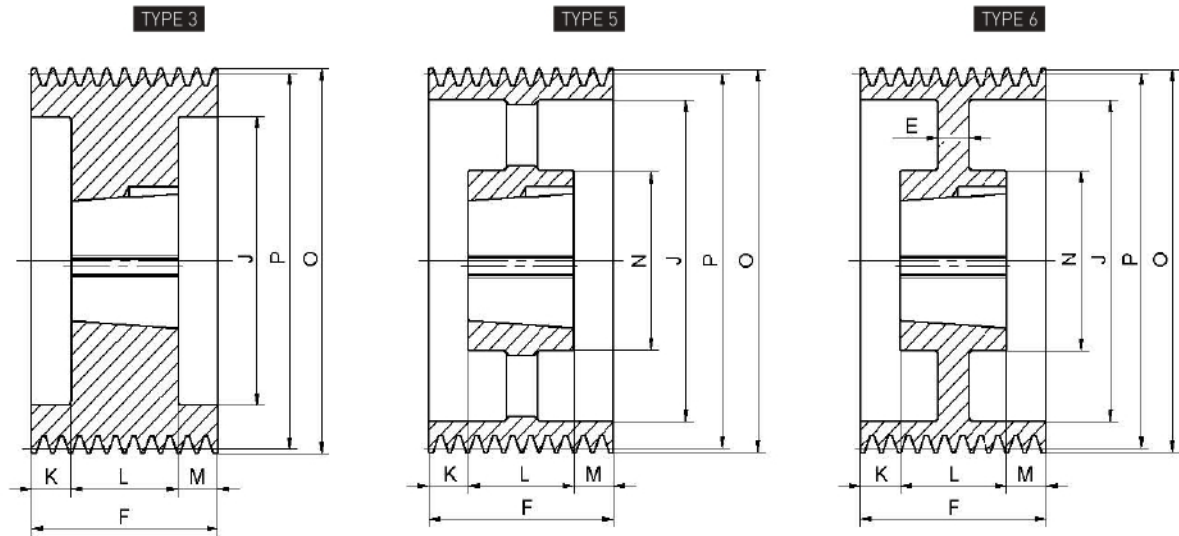

P.M SPB/10

Product Model	Grooves	P	O	TYPE	BUSH	MAX Bore	E	F	J	K	L	M	N	Weight (Kg)
SPB160-10	10	160	167	3	3030	75	—	196	119	60	76	60	—	9.82
SPB170-10	10	170	177	3	3030	75	—	196	127	60	76	60	—	11.88
SPB180-10	10	180	187	3	3030	75	—	196	137	60	76	60	—	13.65
SPB190-10	10	190	197	3	3030	75	—	196	147	60	76	60	—	15.00
SPB200-10	10	200	207	3	3535	90	—	196	157	53.5	89	53.5	—	17.05
SPB212-10	10	212	219	3	3535	90	—	196	169	53.5	89	53.5	—	19.96
SPB224-10	10	224	231	3	3535	90	—	196	181	53.5	89	53.5	—	23.10
SPB236-10	10	236	243	3	3535	90	—	196	193	53.5	89	53.5	—	25.60
SPB241-10	10	241	248	3	3535	90	—	196	198	53.5	89	53.5	—	27.46
SPB250-10	10	250	257	3	3535	90	—	196	207	53.5	89	53.5	—	29.55
SPB265-10	10	265	272	6	3535	90	—	196	222	53.5	89	53.5	175	27.60
SPB280-10	10	280	287	6	3535	90	30	196	237	53.5	89	53.5	175	30.65
SPB300-10	10	300	307	6	3535	90	30	196	257	53.5	89	53.5	175	32.97
SPB315-10	10	315	322	6	3535	90	30	196	272	53.5	89	53.5	175	35.50
SPB335-10	10	335	342	5	4040	100	—	196	292	47.0	102	47.0	210	40.20
SPB355-10	10	355	362	5	4040	100	—	196	312	47.0	102	47.0	210	43.00
SPB375-10	10	375	382	5	4040	100	—	196	332	47.0	102	47.0	210	44.50
SPB400-10	10	400	407	5	4040	100	—	196	357	47.0	102	47.0	210	48.40
SPB450-10	10	450	457	5	4545	110	—	196	407	41.0	114	41.0	242	60.00
SPB500-10	10	500	507	5	4545	110	—	196	457	41	114	41	242	66.80
SPB550-10	10	550	557	5	4545	110	—	196	507	41	114	41	242	73.16
SPB560-10	10	560	567	5	4545	110	—	196	517	41	114	41	242	70.50
SPB630-10	10	630	637	5	4545	110	—	196	587	41	114	41	242	84.15
SPB710-10	10	710	717	5	4545	110	—	196	664	41	114	41	242	95.70
SPB800-10	10	800	807	5	4545	110	—	196	754	41	114	41	242	112.00
SPB900-10	10	900	907	5	5050	125	—	196	854	34.5	127	34.5	267	132.50
SPB1000-10	10	1000	1007	5	5050	125	—	196	954	34.5	127	34.5	267	150.00
SPB1250-10	10	1250	1257	5	5050	125	—	196	1204	34.5	127	34.5	267	201.00

P.M SPC/02

P.M SPC(P.38-P.48)

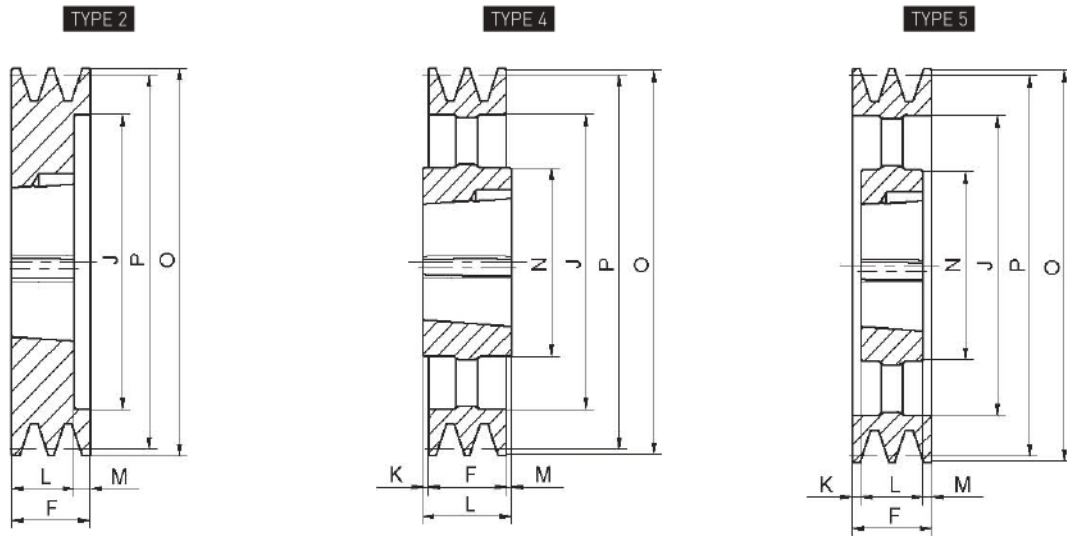

P.M SPC/02

Product Model	Grooves	P	O	TYPE	BUSH	MAX Bore	E	F	J	K	L	M	N	Weight (Kg)
SPC118-02	2	118	127.6	2	1615	42	—	59.5	68	—	38	21.5	—	2.42
SPC120-02	2	120	129.6	2	1615	42	—	59.5	68	—	38	21.5	—	2.65
SPC140-02	2	140	149.6	2	2012	50	—	59.5	84	—	32	27.5	—	3.49
SPC150-02	2	150	159.6	2	2012	50	—	59.5	94	—	32	27.5	—	3.70
SPC160-02	2	160	169.6	2	2517	60	—	59.5	104	—	45	14.5	—	4.58
SPC170-02	2	170	179.6	2	2517	60	—	59.5	114	—	45	14.5	—	5.38
SPC180-02	2	180	189.6	2	2517	60	—	59.5	124	—	45	14.5	—	6.25
SPC190-02	2	190	199.6	2	2517	60	—	59.5	134	—	45	14.5	—	7.20
SPC200-02	2	200	209.6	2	2517	60	—	59.5	144	—	45	14.5	—	8.23
SPC212-02	2	212	221.6	2	2517	60	—	59.5	156	—	45	14.5	—	9.49
SPC224-02	2	224	233.6	2	3020	75	—	59.5	168	—	51	8.5	—	10.30
SPC236-02	2	236	245.6	2	3020	75	—	59.5	180	—	51	8.5	—	11.90
SPC250-02	2	250	259.6	2	3020	75	—	59.5	194	—	51	8.5	—	13.75
SPC265-02	2	265	274.6	2	3020	75	—	59.5	209	—	51	8.5	—	15.96
SPC280-02	2	280	289.6	2	3020	75	—	59.5	224	—	51	8.5	—	21.26
SPC300-02	2	300	309.6	5	3020	75	—	59.5	244	4.25	51	4.25	144	12.90
SPC315-02	2	315	324.6	5	3020	75	—	59.5	259	4.25	51	4.25	144	13.50
SPC335-02	2	335	344.6	5	3020	75	—	59.5	279	4.25	51	4.25	144	15.42
SPC375-02	2	375	384.6	4	3535	90	—	59.5	319	14.75	89	14.75	175	21.96

TAPER BUSHING V-BELT PULLEYS
 ● P.M SPC/02
 ● P.M SPC/03

P.M SPC/03

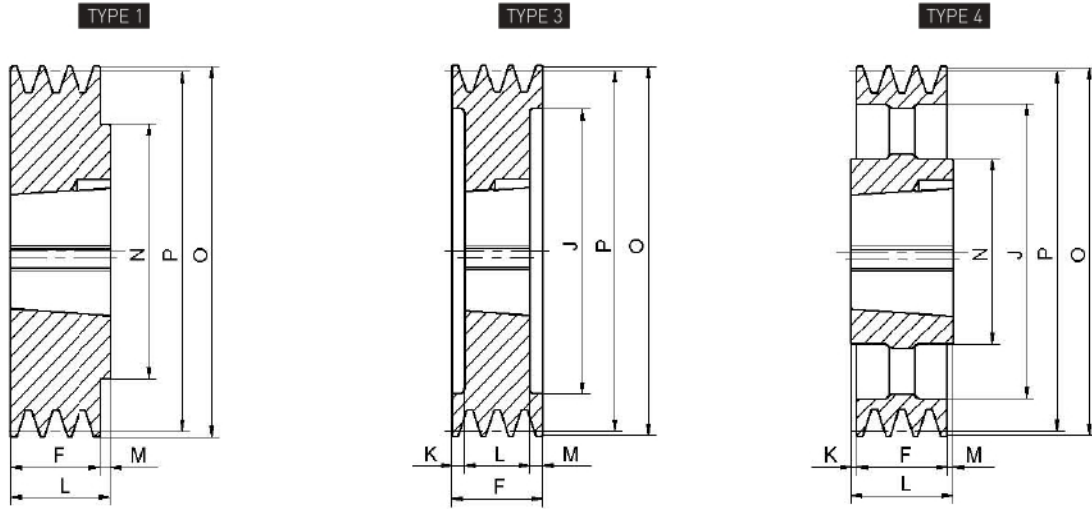

P.M SPC/03

Product Model	Grooves	P	O	TYPE	BUSH	MAX Bore	E	F	J	K	L	M	N	Weight (Kg)
SPC140-03	3	140	149.6	3	2012	50	—	85	84	26.5	32	26.5	—	4.67
SPC150-03	3	150	159.6	3	2012	50	—	85	94	26.5	32	26.5	—	5.33
SPC160-03	3	160	169.6	3	2517	60	—	85	104	20	45	20	—	6.10
SPC170-03	3	170	179.6	3	2517	60	—	85	114	20	45	20	—	6.90
SPC175-03	3	175	184.6	3	2517	60	—	85	119	20	45	20	—	7.20
SPC180-03	3	180	189.6	3	2517	60	—	85	124	20	45	20	—	7.94
SPC190-03	3	190	199.6	3	2517	60	—	85	134	20	45	20	—	8.90
SPC200-03	3	200	209.6	3	2517	60	—	85	144	20	45	20	—	10.06
SPC206-03	3	206	215.6	3	2517	60	—	85	150	20	45	20	—	10.80
SPC212-03	3	212	221.6	3	3020	75	—	85	156	17	51	17	—	10.90
SPC218-03	3	218	227.6	3	3020	75	—	85	162	17	51	17	—	11.66
SPC224-03	3	224	233.6	3	3020	75	—	85	168	17	51	17	—	12.35
SPC230-03	3	230	239.6	3	3020	75	—	85	174	17	51	17	—	13.26
SPC232-03	3	232	241.6	3	3020	75	—	85	176	17	51	17	—	13.50
SPC236-03	3	236	245.6	3	3020	75	—	85	180	17	51	17	—	14.05
SPC240-03	3	240	249.6	3	3020	75	—	85	184	17	51	17	—	14.71
SPC243-03	3	243	252.6	3	3020	75	—	85	187	17	51	17	—	15.05
SPC250-03	3	250	259.6	3	3020	75	—	85	194	17	51	17	—	16.15
SPC258-03	3	258	267.6	1	3535	90	—	85	—	—	89	4	175	21.55
SPC265-03	3	265	274.6	1	3535	90	—	85	—	—	89	4	175	23.31
SPC270-03	3	270	279.6	1	3535	90	—	85	—	—	89	4	175	24.56
SPC273-03	3	273	282.6	1	3535	90	—	85	—	—	89	4	175	25.37
SPC274-03	3	274	283.6	1	3535	90	—	85	—	—	89	4	175	26.00
SPC280-03	3	280	289.6	1	3535	90	—	85	—	—	89	4	175	27.05
SPC290-03	3	290	299.6	1	3535	90	—	85	—	—	89	4	175	29.57
SPC300-03	3	300	309.6	4	3535	90	—	85	244	2	89	2	175	20.63
SPC315-03	3	315	324.6	4	3535	90	—	85	259	2	89	2	175	21.91
SPC325-03	3	325	334.6	4	3535	90	—	85	269	2	89	2	175	22.64
SPC335-03	3	335	344.6	4	3535	90	—	85	279	2	89	2	175	23.65
SPC345-03	3	345	354.6	4	3535	90	—	85	289	2	89	2	175	24.00
SPC355-03	3	355	364.6	4	3535	90	—	85	299	2	89	2	175	24.20

P.M SPC/03

P.M SPC(P.38-P.48)

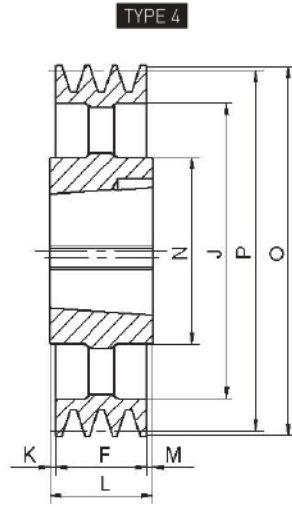

P.M SPC/03

Product Model	Grooves	P	O	TYPE	BUSH	MAX Bore	E	F	J	K	L	M	N	Weight (Kg)
SPC358-03	3	358	367.6	4	3535	90	—	85	302	2	89	2	175	25.00
SPC375-03	3	375	384.6	4	3535	90	—	85	319	2	89	2	175	26.19
SPC400-03	3	400	409.6	4	3535	90	—	85	344	2	89	2	175	27.63
SPC425-03	3	425	434.6	4	3535	90	—	85	369	2	89	2	175	29.00
SPC430-03	3	430	439.6	4	3535	90	—	85	374	2	89	2	175	30.00
SPC450-03	3	450	459.6	4	3535	90	—	85	394	2	89	2	175	31.60
SPC475-03	3	475	484.6	4	3535	90	—	85	419	2	89	2	175	33.25
SPC500-03	3	500	509.6	4	3535	90	—	85	444	2	89	2	175	36.30
SPC530-03	3	530	539.6	4	3535	90	—	85	474	2	89	2	175	38.80
SPC560-03	3	560	569.6	4	3535	90	—	85	504	2	89	2	175	40.12
SPC630-03	3	630	639.6	4	4040	100	—	85	574	8.5	102	8.5	210	51.45
SPC710-03	3	710	719.6	4	4040	100	—	85	654	8.5	102	8.5	210	58.00
SPC800-03	3	800	809.6	4	4545	110	—	85	737	14.5	114	14.5	242	79.00
SPC1000-03	3	1000	1009.6	4	5050	125	—	85	937	21	127	21	267	120.50
SPC1250-03	3	1250	1259.6	4	5050	125	—	85	1187	21	127	21	267	136.00

P.M SPC/04

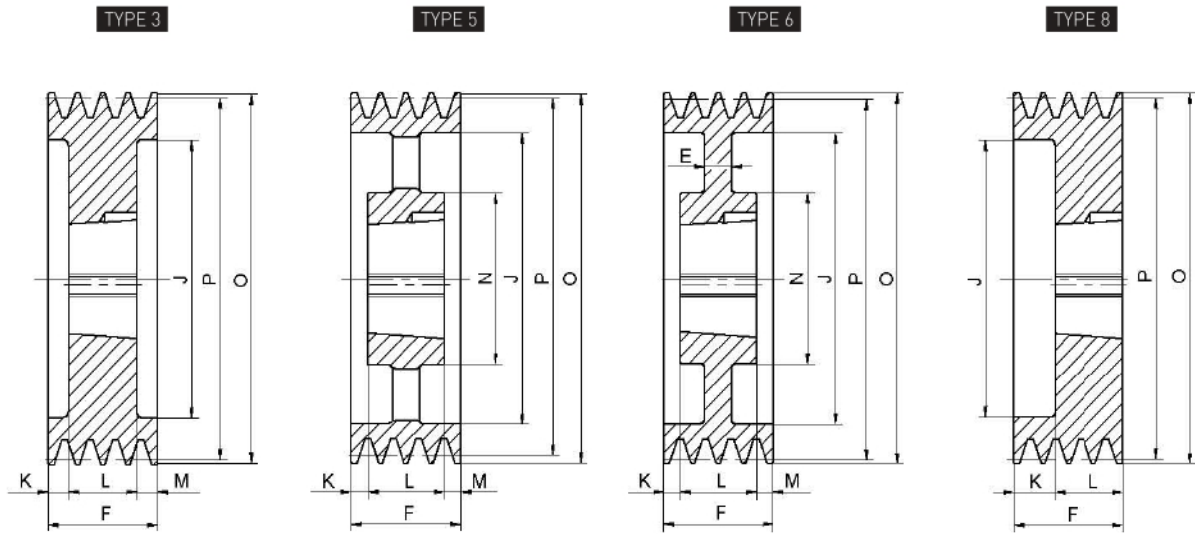

P.M SPC/04

Product Model	Grooves	P	O	TYPE	BUSH	MAX Bore	E	F	J	K	L	M	N	Weight (Kg)
SPC125-04	4	125	134.6	8	1615	42	—	111	69	73	38	—	—	5.07
SPC150-04	4	150	159.6	3	2012	50	—	111	94	39.5	32	39.5	—	6.70
SPC160-04	4	160	169.6	3	2517	60	—	111	104	33	45	33	—	7.34
SPC170-04	4	170	179.6	3	3020	75	—	111	120	30	51	30	—	6.90
SPC175-04	4	175	184.6	3	3020	75	—	111	119	30	51	30	—	8.08
SPC180-04	4	180	189.6	3	3020	75	—	111	124	30	51	30	—	8.65
SPC190-04	4	190	199.6	3	3020	75	—	111	134	30	51	30	—	9.82
SPC200-04	4	200	209.6	3	3020	75	—	111	144	30	51	30	—	11.15
SPC206-04	4	206	215.6	3	3020	75	—	111	150	30	51	30	—	11.64
SPC212-04	4	212	221.6	3	3020	75	—	111	156	30	51	30	—	12.76
SPC218-04	4	218	227.6	3	3020	75	—	111	162	30	51	30	—	13.70
SPC224-04	4	224	233.6	3	3535	90	—	111	168	11	89	11	—	16.30
SPC228-04	4	228	237.6	3	3535	90	—	111	172	11	89	11	—	16.87
SPC232-04	4	232	241.6	3	3535	90	—	111	176	11	89	11	—	18.13
SPC236-04	4	236	245.6	3	3535	90	—	111	180	11	89	11	—	18.90
SPC240-04	4	240	249.6	3	3535	90	—	111	184	11	89	11	—	19.99
SPC243-04	4	243	252.6	3	3535	90	—	111	187	11	89	11	—	20.80
SPC250-04	4	250	259.6	3	3535	90	—	111	194	11	89	11	—	22.00
SPC255-04	4	255	264.6	3	3535	90	—	111	199	11	89	11	—	23.80
SPC258-04	4	258	267.6	3	3535	90	—	111	202	11	89	11	—	24.30
SPC265-04	4	265	274.6	3	3535	90	—	111	209	11	89	11	—	26.15
SPC270-04	4	270	279.6	6	3535	90	18	111	214	11	89	11	175	21.50
SPC273-04	4	273	282.6	6	3535	90	18	111	217	11	89	11	175	21.65
SPC280-04	4	280	289.6	6	3535	90	18	111	224	11	89	11	175	22.51
SPC290-04	4	290	299.6	6	3535	90	20	111	234	11	89	11	175	23.76
SPC300-04	4	300	309.6	6	3535	90	20	111	244	11	89	11	175	24.60
SPC308-04	4	308	317.6	6	3535	90	20	111	252	11	89	11	175	25.55
SPC315-04	4	315	324.6	5	3535	90	—	111	259	11	89	11	175	24.73
SPC325-04	4	325	334.6	5	3535	90	—	111	269	11	89	11	175	26.35
SPC335-04	4	335	344.6	5	3535	90	—	111	279	11	89	11	175	27.45

P.M SPC/04

P.M SPC(P.38-P.48)

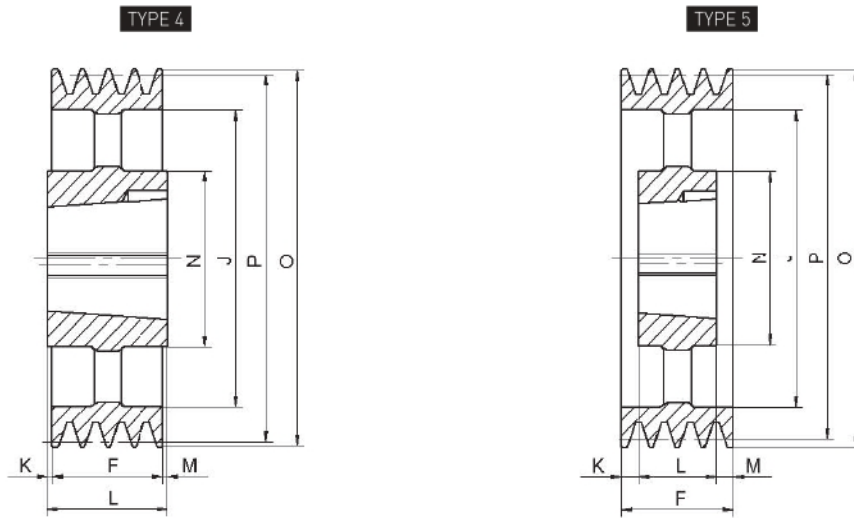

P.M SPC/04

Product Model	Grooves	P	O	TYPE	BUSH	MAX Bore	E	F	J	K	L	M	N	Weight (Kg)
SPC345-04	4	345	354.6	5	3535	90	—	111	289	11	89	11	175	28.40
SPC355-04	4	355	364.6	5	3535	90	—	111	299	11	89	11	175	29.15
SPC375-04	4	375	384.6	5	3535	90	—	111	319	11	89	11	175	30.60
SPC400-04	4	400	409.6	5	3535	90	—	111	344	11	89	11	175	33.27
SPC425-04	4	425	434.6	5	3535	90	—	111	369	11	89	11	175	34.95
SPC450-04	4	450	459.6	5	3535	90	—	111	394	11	89	11	175	36.80
SPC475-04	4	475	484.6	5	3535	90	—	111	419	11	89	11	175	38.95
SPC500-04	4	500	509.6	5	3535	90	—	111	444	11	89	11	175	42.60
SPC530-04	4	530	539.6	5	4040	100	—	111	474	4.5	102	4.5	210	51.05
SPC560-04	4	560	569.6	5	4040	100	—	111	504	4.5	102	4.5	210	53.15
SPC630-04	4	630	639.6	4	4545	110	—	111	574	1.5	114	1.5	242	68.20
SPC710-04	4	710	719.6	4	5050	125	—	111	654	8	127	8	267	86.16
SPC800-04	4	800	809.6	4	5050	125	—	111	737	8	127	8	267	97.15
SPC1000-04	4	1000	1009.6	4	5050	125	—	111	937	8	127	8	267	125.00
SPC1250-04	4	1250	1259.6	4	5050	125	—	111	1187	8	127	8	267	166.00

TAPER BUSHING V-BELT PULLEYS
 ● P.M SPC/04
 ● P.M SPC/05

P.M SPC/05

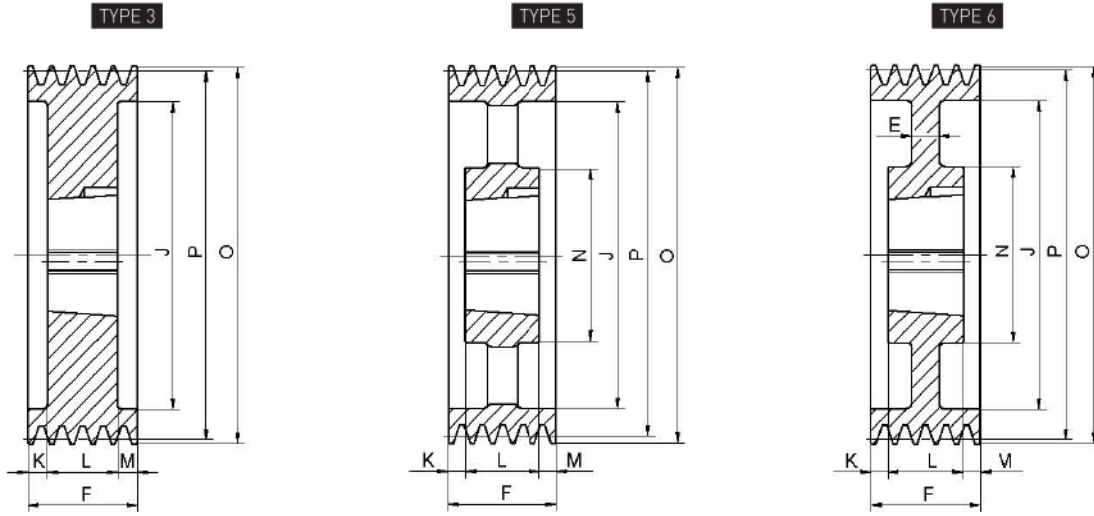

P.M SPC/05

Product Model	Grooves	P	O	TYPE	BUSH	MAX Bore	E	F	J	K	L	M	N	Weight (Kg)
SPC150-05	5	150	159.6	3	2012	50	—	136	94	52	32	52	—	8.00
SPC170-05	5	170	179.6	3	3020	75	—	136	119	42.5	51	42.5	—	8.22
SPC190-05	5	190	199.6	3	3020	75	—	136	134	42.5	51	42.5	—	11.53
SPC200-05	5	200	209.6	3	3535	90	—	136	144	23.5	89	23.5	—	13.07
SPC212-05	5	212	221.6	3	3535	90	—	136	156	23.5	89	23.5	—	15.60
SPC218-05	5	218	227.6	3	3535	90	—	136	162	23.5	89	23.5	—	16.88
SPC224-05	5	224	233.6	3	3535	90	—	136	168	23.5	89	23.5	—	18.30
SPC236-05	5	236	245.6	3	3535	90	—	136	180	23.5	89	23.5	—	21.17
SPC250-05	5	250	259.6	3	3535	90	—	136	194	23.5	89	23.5	—	24.55
SPC258-05	5	258	267.6	3	3535	90	—	136	202	23.5	89	23.5	—	27.00
SPC260-05	5	260	269.6	3	3535	90	—	136	204	23.5	89	23.5	—	27.28
SPC265-05	5	265	274.6	3	3535	90	—	136	209	23.5	89	23.5	—	28.69
SPC280-05	5	280	289.6	3	3535	90	—	136	224	23.5	89	23.5	—	32.81
SPC300-05	5	300	309.6	6	3535	90	20	136	244	23.5	89	23.5	175	29.80
SPC315-05	5	315	324.6	5	3535	90	—	136	259	23.5	89	23.5	175	28.21
SPC335-05	5	335	344.6	5	3535	90	—	136	279	23.5	89	23.5	175	30.70
SPC350-05	5	350	359.6	5	3535	90	—	136	294	23.5	89	23.5	175	32.02
SPC355-05	5	355	364.6	5	3535	90	—	136	299	23.5	89	23.5	175	33.12
SPC375-05	5	375	384.6	5	3535	90	—	136	319	23.5	89	23.5	175	34.72
SPC400-05	5	400	409.6	5	3535	90	—	136	344	23.5	89	23.5	175	37.40
SPC415-05	5	415	424.6	5	3535	90	—	136	359	23.5	89	23.5	175	38.00
SPC425-05	5	425	434.6	5	3535	90	—	136	369	23.5	89	23.5	175	40.40
SPC450-05	5	450	459.6	5	4040	100	—	136	394	17	102	17	210	48.10
SPC475-05	5	475	484.6	5	4040	100	—	136	419	17	102	17	210	50.70
SPC500-05	5	500	509.6	5	4040	100	—	136	444	17	102	17	210	54.00
SPC530-05	5	530	539.6	5	4545	110	—	136	474	11	114	11	240	64.07
SPC560-05	5	560	569.6	5	4545	110	—	136	504	11	114	11	242	66.77
SPC630-05	5	630	639.6	5	5050	125	—	136	574	4.5	127	4.5	267	82.00
SPC710-05	5	710	719.6	5	5050	125	—	136	654	4.5	127	4.5	267	93.20
SPC800-05	5	800	809.6	5	5050	125	—	136	737	4.5	127	4.5	267	110.00
SPC900-05	5	900	909.6	5	5050	125	—	136	837	4.5	127	4.5	267	135.00
SPC1000-05	5	1000	1009.6	5	5050	125	—	136	937	4.5	127	4.5	267	154.00
SPC1120-05	5	1120	1129.6	5	5050	125	—	136	1057	4.5	127	4.5	267	194.35
SPC1250-05	5	1250	1259.6	5	5050	125	—	136	1187	4.5	127	4.5	267	188.00

P.M SPC/06

P.M SPC(P.38-P.48)

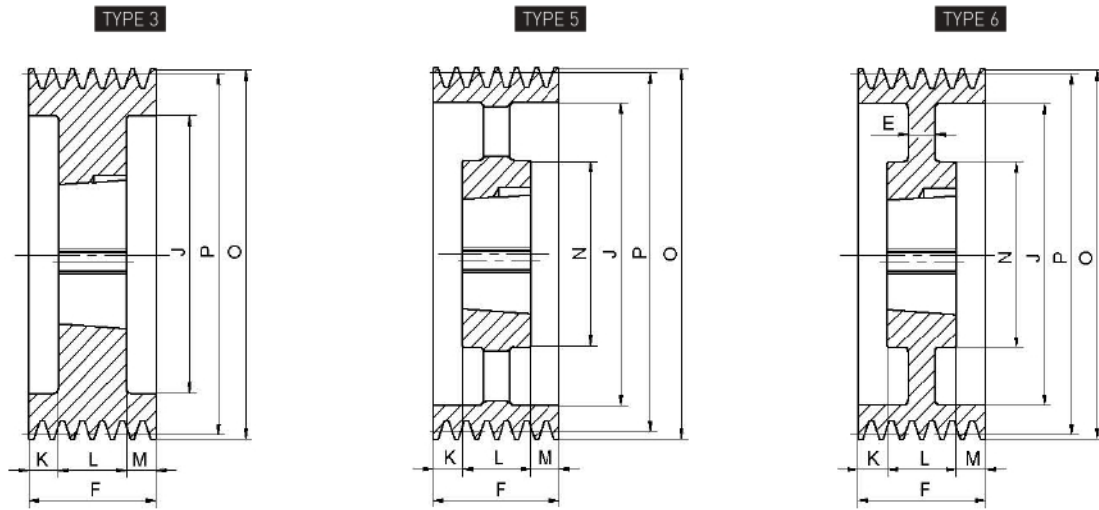

P.M SPC/06

Product Model	Grooves	P	O	TYPE	BUSH	MAX Bore	E	F	J	K	L	M	N	Weight (Kg)
SPC180-06	6	180	189.6	3	3020	75	—	162	124	55.5	51	55.5	—	11.88
SPC190-06	6	190	199.6	3	3020	75	—	162	134	55.5	51	55.5	—	12.50
SPC200-06	6	200	209.6	3	3535	90	—	162	144	36.5	89	36.5	—	14.80
SPC212-06	6	212	221.6	3	3535	90	—	162	156	36.5	89	36.5	—	17.70
SPC224-06	6	224	233.6	3	3535	90	—	162	168	36.5	89	36.5	—	20.30
SPC228-06	6	228	237.6	3	3535	90	—	162	172	36.5	89	36.5	—	21.51
SPC232-06	6	232	241.6	3	3535	90	—	162	172	36.5	89	36.5	—	23.00
SPC236-06	6	236	245.6	3	3535	90	—	162	180	36.5	89	36.5	—	23.31
SPC240-06	6	240	249.6	3	3535	90	—	162	184	36.5	89	36.5	—	24.52
SPC243-06	6	243	252.6	3	3535	90	—	162	187	36.5	89	36.5	—	25.15
SPC245-06	6	245	254.6	3	3535	90	—	162	189	36.5	89	36.5	—	26.80
SPC250-06	6	250	259.6	3	3535	90	—	162	194	36.5	89	36.5	—	27.17
SPC258-06	6	258	267.6	3	3535	90	—	162	202	36.5	89	36.5	—	29.19
SPC265-06	6	265	274.6	3	3535	90	—	162	209	36.5	89	36.5	—	31.23
SPC273-06	6	273	282.6	6	3535	90	20	162	217	36.5	89	36.5	175	28.60
SPC280-06	6	280	289.6	6	3535	90	20	162	224	36.5	89	36.5	175	28.90
SPC290-06	6	290	299.6	6	3535	90	20	162	234	36.5	89	36.5	175	29.42
SPC300-06	6	300	309.6	6	3535	90	20	162	244	36.5	89	36.5	175	30.35
SPC308-06	6	308	317.6	6	3535	90	20	162	252	36.5	89	36.5	175	31.80
SPC315-06	6	315	324.6	5	3535	90	—	162	259	36.5	89	36.5	175	31.35
SPC335-06	6	335	344.6	5	3535	90	—	162	279	36.5	89	36.5	175	35.00
SPC345-06	6	345	354.6	5	3535	90	—	162	289	36.5	89	36.5	175	36.19
SPC355-06	6	355	364.6	5	3535	90	—	162	299	36.5	89	36.5	175	37.10
SPC375-06	6	375	384.6	5	4040	100	—	162	319	30.0	102	30.0	210	45.05
SPC385-06	6	385	394.6	5	4040	100	—	162	329	30.0	102	30.0	210	45.30
SPC400-06	6	400	409.6	5	4040	100	—	162	344	30.0	102	30.0	210	47.76
SPC425-06	6	425	434.6	5	4040	100	—	162	369	30.0	102	30.0	210	50.25
SPC435-06	6	435	444.6	5	4040	100	—	162	379	30.0	102	30.0	210	52.88
SPC440-06	6	440	449.6	5	4545	110	—	162	384	24.0	114	24.0	242	58.90
SPC450-06	6	450	459.6	5	4545	110	—	162	394	24.0	114	24.0	242	60.98
SPC475-06	6	475	484.6	5	4545	110	—	162	419	24.0	114	24.0	242	63.00
SPC500-06	6	500	509.6	5	4545	110	—	162	444	24	114	24	242	67.60
SPC530-06	6	530	539.6	5	5050	125	—	162	474	17.5	127	17.5	265	76.70
SPC560-06	6	560	569.6	5	5050	125	—	162	504	17.5	127	17.5	267	81.40

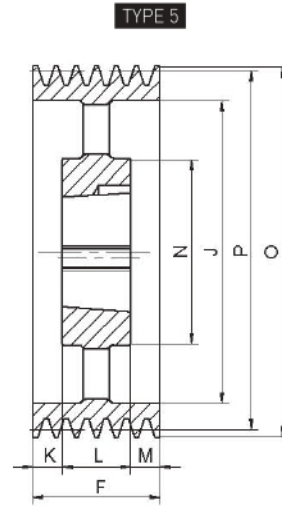

P.M SPC/06

Product Model	Grooves	P	O	TYPE	BUSH	MAX Bore	E	F	J	K	L	M	N	Weight (Kg)
SPC600-06	6	600	609.6	5	5050	125	—	162	544	17.5	127	17.5	267	85.45
SPC630-06	6	630	639.6	5	5050	125	—	162	574	17.5	127	17.5	267	89.70
SPC710-06	6	710	719.6	5	5050	125	—	162	654	17.5	127	17.5	267	102.60
SPC800-06	6	800	809.6	5	5050	125	—	162	737	17.5	127	17.5	267	123.60
SPC860-06	6	860	869.6	5	5050	125	—	162	797	17.5	127	17.5	267	133.00
SPC932-06	6	932	941.6	5	5050	125	—	162	869	17.5	127	17.5	267	145.61
SPC1000-06	6	1000	1009.6	5	5050	125	—	162	937	17.5	127	17.5	267	160.00
SPC1120-06	6	1120	1129.6	5	5050	125	—	162	1057	17.5	127	17.5	267	184.50
SPC1250-06	6	1250	1259.6	5	5050	125	—	162	1187	17.5	127	17.5	267	201.00
SPC1400-06	6	1400	1409.6	5	6050	160	—	162	1337	17.5	127	17.5	432	315.00
SPC1600-06	6	1600	1609.6	5	6050	160	—	162	1537	17.5	127	17.5	432	387.00
SPC1700-06	6	1700	1709.6	5	6050	160	—	162	1637	17.5	127	17.5	432	389.00

P.M SPC/08

P.M SPC(P.38-P.48)

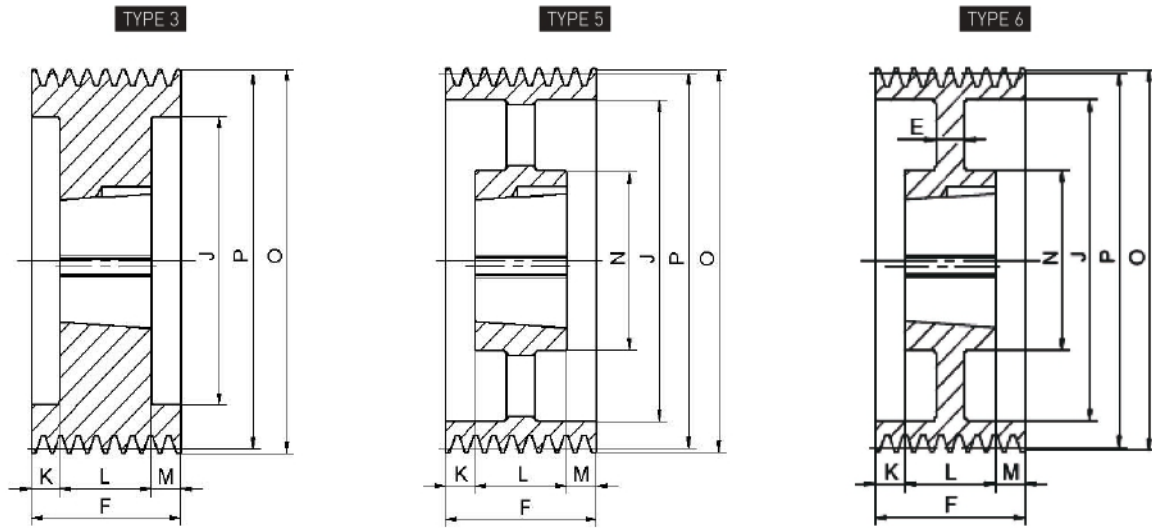

P.M SPC/08

Product Model	Grooves	P	O	TYPE	BUSH	MAX Bore	E	F	J	K	L	M	N	Weight (Kg)
SPC200-08	8	200	209.6	3	3535	90	—	213	144	62	89	62	—	18.52
SPC212-08	8	212	221.6	3	3535	90	—	213	156	62	89	62	—	21.50
SPC224-08	8	224	233.6	3	3535	90	—	213	168	62	89	62	—	24.85
SPC236-08	8	236	245.6	3	3535	90	—	213	180	62	89	62	—	27.60
SPC250-08	8	250	259.6	3	3535	90	—	213	194	62	89	62	—	31.90
SPC265-08	8	265	274.6	3	3535	90	—	213	209	62	89	62	—	36.35
SPC280-08	8	280	289.6	3	3535	90	—	213	224	62	89	62	—	40.60
SPC300-08	8	300	309.6	3	4040	100	—	213	244	55.5	102	55.5	—	47.71
SPC315-08	8	315	324.6	3	4040	100	—	213	259	55.5	102	55.5	—	53.92
SPC335-08	8	335	344.6	6	4040	100	50	213	279	55.5	102	55.5	210	53.00
SPC355-08	8	355	364.6	5	4040	100	—	213	299	55.5	102	55.5	210	50.67
SPC375-08	8	375	384.6	5	4545	110	—	213	319	49.5	114	49.5	242	60.15
SPC400-08	8	400	409.6	5	4545	110	—	213	344	49.5	114	49.5	242	65.10
SPC425-08	8	425	434.6	5	4545	110	—	213	369	49.5	114	49.5	242	68.11
SPC450-08	8	450	459.6	5	5050	125	—	213	394	43.0	127	43.0	267	77.33
SPC475-08	8	475	484.6	5	5050	125	—	213	419	43.0	127	43.0	267	85.20
SPC500-08	8	500	509.6	5	5050	125	—	213	444	43.0	127	43.0	267	88.70
SPC530-08	8	530	539.6	5	5050	125	—	213	474	43.0	127	43.0	267	94.05
SPC560-08	8	560	569.6	5	5050	125	—	213	504	43	127	43	267	95.80
SPC600-08	8	600	609.6	5	5050	125	—	213	544	43	127	43	267	102.16
SPC630-08	8	630	639.6	5	5050	125	—	213	574	43	127	43	267	106.00
SPC680-08	8	680	689.6	5	5050	125	—	213	624	43	127	43	267	117.50
SPC710-08	8	710	719.6	5	5050	125	—	213	654	43	127	43	267	124.00
SPC800-08	8	800	809.6	5	5050	125	—	213	737	43	127	43	267	150.00
SPC900-08	8	900	909.6	5	5050	125	—	213	837	43	127	43	267	173.00
SPC1000-08	8	1000	1009.6	5	5050	125	—	213	937	43	127	43	267	191.00
SPC1120-08	8	1120	1129.6	5	5050	125	—	213	1057	43	127	43	267	234.00
SPC1250-08	8	1250	1259.6	5	5050	125	—	213	1187	43	127	43	267	255.00
SPC1400-08	8	1400	1409.6	5	6050	150	—	213	1337	43	127	43	432	384.00
SPC1600-08	8	1600	1609.6	5	6050	150	—	213	1537	43	127	43	432	510.00

P.M SPC/10

TAPER BUSHING V-BELT PULLEYS
 ● P.M SPC/08
 ● P.M SPC/10

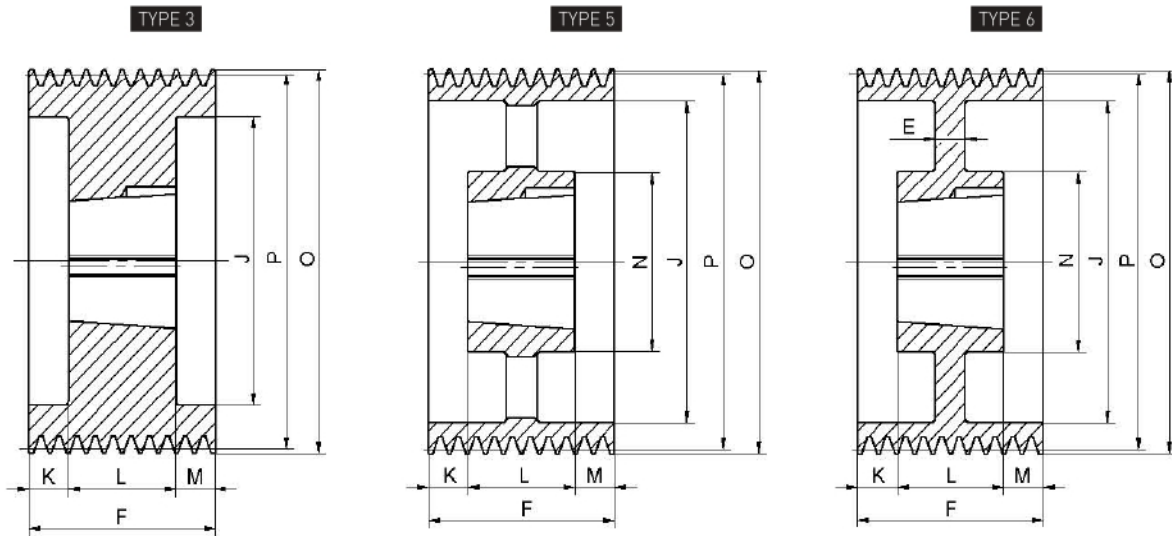

P.M SPC/10

Product Model	Grooves	P	O	TYPE	BUSH	MAX Bore	E	F	J	K	L	M	N	Weight (Kg)
SPC200-10	10	200	209.6	3	3535	90	—	264	144	87.5	89	87.5	—	22.05
SPC224-10	10	224	233.6	3	4040	100	—	264	168	81	102	81	—	27.00
SPC230-10	10	230	239.6	3	4040	100	—	264	174	81	102	81	—	28.60
SPC236-10	10	236	245.6	3	4040	100	—	264	180	81	102	81	—	30.29
SPC250-10	10	250	259.6	3	4040	100	—	264	194	81	102	81	—	35.35
SPC265-10	10	265	274.6	3	4040	100	—	264	209	81	102	81	—	40.67
SPC280-10	10	280	289.6	3	4040	100	—	264	224	81	102	81	—	45.92
SPC290-10	10	290	299.6	3	4545	110	—	264	234	75	114	75	—	50.00
SPC300-10	10	300	309.6	3	4545	110	—	264	244	75	114	75	—	54.00
SPC315-10	10	315	324.6	3	4545	110	—	264	259	75	114	75	—	59.70
SPC325-10	10	325	334.6	3	4545	110	—	264	269	75	114	75	—	66.40
SPC335-10	10	335	344.6	3	4545	110	—	264	279	75	114	75	—	71.00
SPC340-10	10	340	349.6	3	4545	110	—	264	284	75	114	75	—	73.82
SPC355-10	10	355	364.6	3	4545	110	—	264	299	75	114	75	—	80.50
SPC360-10	10	360	369.6	3	4545	110	—	264	304	75	114	75	—	83.83
SPC375-10	10	375	384.6	3	4545	110	—	264	319	75	114	75	—	91.00
SPC400-10	10	400	409.6	6	5050	125	70	264	344	68.5	127	68.5	267	92.00
SPC425-10	10	425	434.6	6	5050	125	50	264	369	68.5	127	68.5	267	96.20
SPC450-10	10	450	459.6	5	5050	125	—	264	394	68.5	127	68.5	267	89.40
SPC475-10	10	475	484.6	5	5050	125	—	264	419	68.5	127	68.5	267	93.20
SPC500-10	10	500	509.6	5	5050	125	—	264	444	68.5	127	68.5	267	100.00
SPC530-10	10	530	539.6	5	5050	125	—	264	474	68.5	127	68.5	267	109.00
SPC560-10	10	560	569.6	5	5050	125	—	264	504	68.5	127	68.5	267	114.00
SPC590-10	10	590	599.6	5	5050	125	—	264	534	68.5	127	68.5	267	118.00
SPC630-10	10	630	639.6	5	5050	125	—	264	574	68.5	127	68.5	267	128.00
SPC710-10	10	710	719.6	5	5050	125	—	264	654	68.5	127	68.5	267	148.00
SPC800-10	10	800	809.6	5	5050	125	—	264	737	68.5	127	68.5	267	174.00
SPC900-10	10	900	909.6	5	5050	125	—	264	837	68.5	127	68.5	267	209.30
SPC1000-10	10	1000	1009.6	5	5050	125	—	264	937	68.5	127	68.5	267	222.00
SPC1250-10	10	1250	1259.6	5	5050	125	—	264	1187	68.5	127	68.5	267	311.00
SPC1600-10	10	1600	1609.6	5	5050	125	—	264	1537	68.5	127	68.5	288	460.00
SPC1700-10	10	1700	1709.6	5	7060	175	—	264	1637	56	152	56	500	488.75
SPC1900-10	10	1900	1909.6	5	7060	175	—	264	1837	56	152	56	500	752.00

P.M SPC/12

P.M SPC(P.38-P.48)

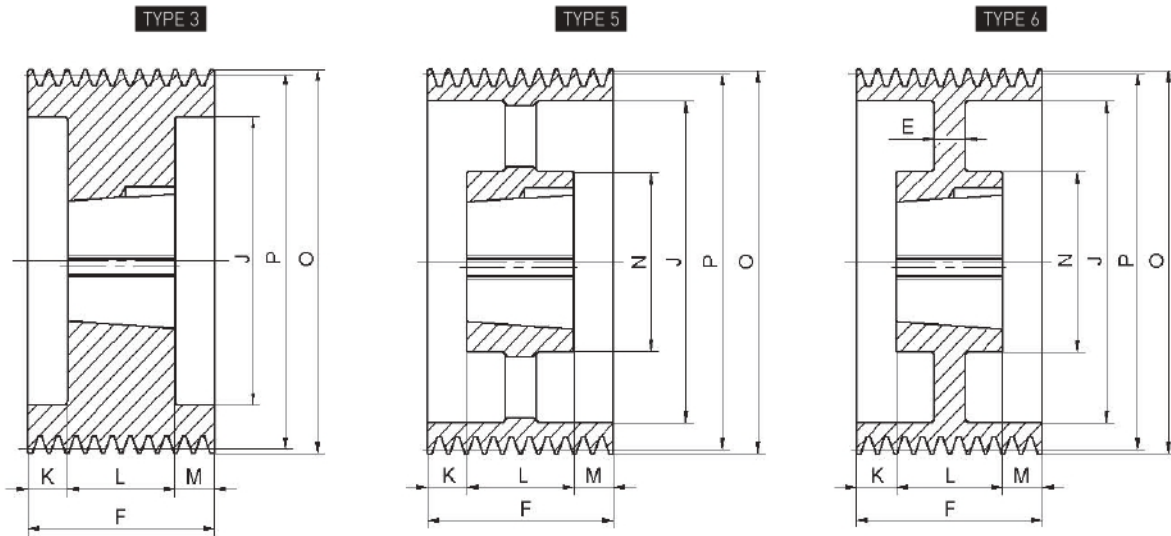

P.M SPC/12

Product Model	Grooves	P	O	TYPE	BUSH	MAX Bore	E	F	J	K	L	M	N	Weight (Kg)
SPC265-12	12	265	274.6	3	4545	110	—	315	209	100.5	114	100.5	—	44.00
SPC280-12	12	280	289.6	3	4545	110	—	315	224	100.5	114	100.5	—	51.10
SPC300-12	12	300	309.6	3	4545	110	—	315	244	100.5	114	100.5	—	58.50
SPC315-12	12	315	324.6	3	5050	125	—	315	259	94	127	94	—	66.30
SPC325-12	12	325	334.6	3	5050	125	—	315	269	94	127	94	—	74.50
SPC335-12	12	335	344.6	3	5050	125	—	315	279	94	127	94	—	76.00
SPC355-12	12	355	364.6	6	5050	125	50	315	299	94	127	94	267	88.00
SPC375-12	12	375	384.6	6	5050	125	50	315	319	94	127	94	267	90.00
SPC400-12	12	400	409.6	6	5050	125	50	315	344	94	127	94	267	96.00
SPC450-12	12	450	459.6	6	5050	125	50	315	394	94	127	94	267	116.00
SPC475-12	12	475	484.6	6	5050	125	50	315	419	94	127	94	267	123.00
SPC500-12	12	500	509.6	6	5050	125	45	315	444	94	127	94	267	128.00
SPC600-12	12	600	609.6	5	5050	125	45	315	544	94	127	94	267	142.00
SPC630-12	12	630	639.6	5	5050	125	45	315	574	94	127	94	267	147.00
SPC710-12	12	710	719.6	5	5050	125	45	315	654	94	127	94	267	166.00
SPC800-12	12	800	809.6	5	5050	125	45	315	737	94	127	94	267	208.00
SPC1000-12	12	1000	1009.6	5	5050	125	50	315	937	94	127	94	267	236.00
SPC1250-12	12	1250	1259.6	5	5050	125	45	315	1187	94	127	94	267	350.00
SPC1400-12	12	1400	1409.6	5	7060	175	50	315	1337	81.5	152	81.5	500	551.00

P.M SPZ/1

P.M SPC(P.49-P.51)

TAPER BUSHING V-BELT PULLEYS
 ● P.M SPC/12
 PILOT BORED V-BELT PULLEYS
 ● P.M SPZ/1

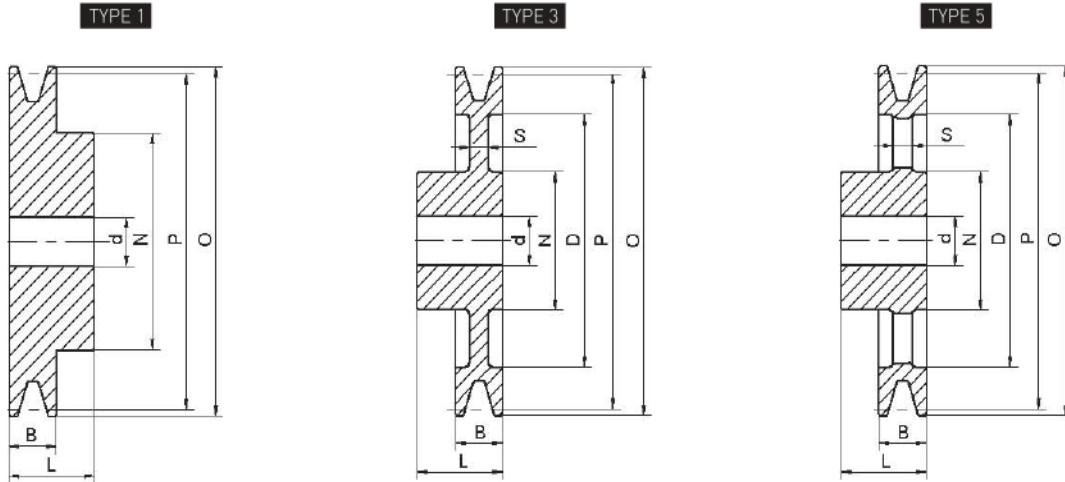

P.M SPZ/1

Product Model	P	O	Grooves	N	L	D	S	B	TYPE	d (H9)	Weight (Kg)
SPZ45-1	45	49	1	40	28			16	1	10	0.25
SPZ50-1	50	54	1	40	28			16	1	10	0.25
SPZ56-1	56	60	1	45	28			16	1	10	0.36
SPZ63-1	63	67	1	50	28			16	1	10	0.47
SPZ71-1	71	75	1	50	28			16	1	10	0.56
SPZ75-1	75	79	1	50	28			16	1	10	0.60
SPZ80-1	80	84	1	50	28			16	1	10	0.67
SPZ85-1	85	89	1	50	28			16	1	10	0.75
SPZ90-1	90	94	1	50	28			16	1	10	0.82
SPZ95-1	95	99	1	50	28			16	1	10	0.90
SPZ100-1	100	104	1	50	28			16	1	10	0.99
SPZ106-1	106	110	1	50	28			16	1	10	1.10
SPZ112-1	112	116	1	50	28			16	1	10	1.21
SPZ118-1	118	122	1	50	28	93	8	16	3	10	1.05
SPZ125-1	125	129	1	50	28	100	8	16	3	15	1.12
SPZ132-1	132	136	1	50	28	106	8	16	3	15	1.24
SPZ140-1	140	144	1	50	28	114	8	16	3	15	1.34
SPZ150-1	150	154	1	50	28	124	8	16	3	15	1.49
SPZ160-1	160	164	1	55	32	134	8	16	3	15	1.78
SPZ170-1	170	174	1	55	32	144	8	16	3	15	1.92
SPZ180-1	180	184	1	55	32	154	8	16	5	20	1.57
SPZ190-1	190	194	1	55	32	164	8	16	5	20	1.60
SPZ200-1	200	204	1	55	32	174	8	16	5	20	1.73
SPZ212-1	212	216	1	55	32	186	8	16	5	20	1.80
SPZ224-1	224	228	1	55	32	198	8	16	5	20	1.88
SPZ250-1	250	254	1	55	32	224	8	16	5	20	2.13
SPZ280-1	280	284	1	55	32	254	8	16	5	20	2.40
SPZ315-1	315	319	1	55	32	289	10	16	5	20	2.98
SPZ355-1	355	359	1	60	32	328	10	16	5	20	3.10

P.M SPZ/2

P.M SPC[P.49-P.51]

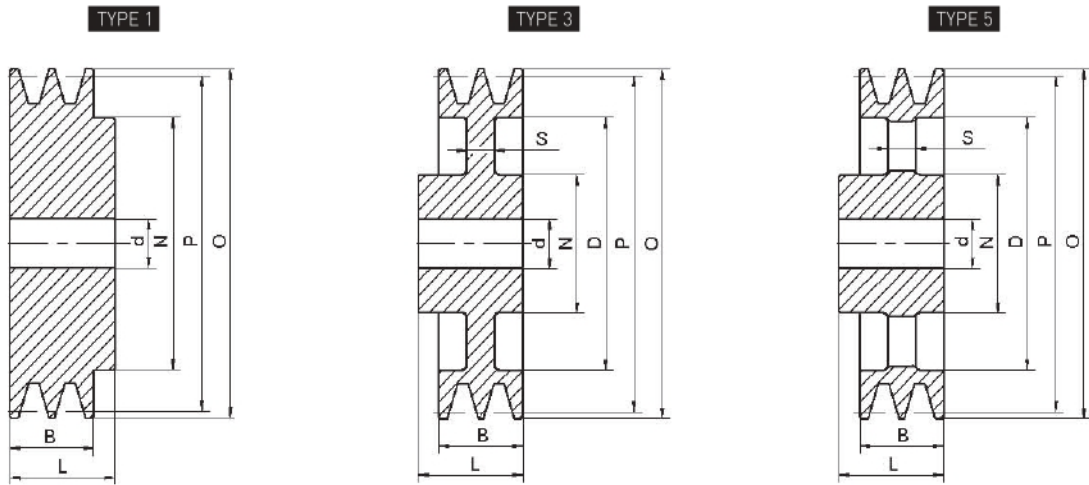

P.M SPZ/2

Product Model	P	O	Grooves	N	L	D	S	B	TYPE	d (H9)	Weight (Kg)
SPZ45-2	45	49	2	40	35			28	1	10	0.30
SPZ50-2	50	54	2	40	35			28	1	10	0.36
SPZ56-2	56	60	2	45	35			28	1	10	0.47
SPZ63-2	63	67	2	50	35			28	1	10	0.60
SPZ67-2	67	71	2	50	35			28	1	10	0.67
SPZ71-2	71	75	2	55	35			28	1	10	0.78
SPZ75-2	75	79	2	60	35			28	1	10	0.89
SPZ80-2	80	84	2	60	35			28	1	10	1.00
SPZ85-2	85	89	2	60	35			28	1	10	1.14
SPZ90-2	90	94	2	60	35			28	1	10	1.28
SPZ95-2	95	99	2	60	35			28	1	15	1.39
SPZ100-2	100	104	2	60	35			28	1	15	1.53
SPZ106-2	106	110	2	60	35			28	1	15	1.72
SPZ112-2	112	116	2	60	35			28	1	15	1.91
SPZ118-2	118	122	2	60	35	91	8	28	3	15	1.58
SPZ125-2	125	129	2	60	35	99	8	28	3	15	1.69
SPZ132-2	132	136	2	60	40	106	8	28	3	15	1.89
SPZ140-2	140	144	2	60	40	114	8	28	3	15	2.04
SPZ150-2	150	154	2	60	40	124	8	28	3	15	2.19
SPZ160-2	160	164	2	60	40	134	8	28	3	15	2.23
SPZ170-2	170	174	2	60	40	144	8	28	3	15	2.26
SPZ180-2	180	184	2	60	40	154	8	28	5	20	2.29
SPZ190-2	190	194	2	60	40	164	8	28	5	20	2.38
SPZ200-2	200	204	2	60	40	174	8	28	5	20	2.49
SPZ212-2	212	216	2	60	40	186	8	28	5	20	2.62
SPZ224-2	224	228	2	60	40	198	8	28	5	20	2.76
SPZ250-2	250	254	2	60	40	224	10	28	5	20	3.52
SPZ280-2	280	284	2	65	45	254	10	28	5	20	3.85
SPZ315-2	315	319	2	65	45	289	10	28	5	20	4.40
SPZ355-2	355	359	2	68	45	328	12	28	5	20	5.50
SPZ400-2	400	404	2	75	45	372	12	28	5	20	6.50

P.M SPZ/3

PILOT BORED V-BELT PULLEYS
 ● P.M SPZ/2
 ● P.M SPZ/3

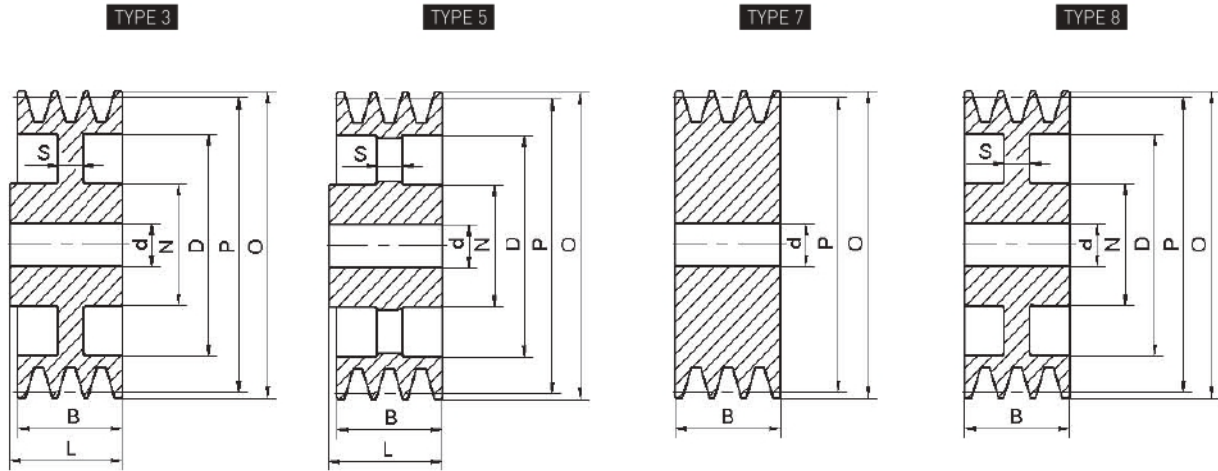

P.M SPZ/3

Product Model	P	O	Grooves	N	L	D	S	B	TYPE	d (H9)	Weight (Kg)
SPZ50-3	50	54	3					40	7	10	0.42
SPZ56-3	56	60	3					40	7	10	0.55
SPZ63-3	63	67	3					40	7	10	0.71
SPZ71-3	71	75	3					40	7	10	0.94
SPZ75-3	75	79	3					40	7	10	1.06
SPZ80-3	80	84	3					40	7	10	1.22
SPZ85-3	85	89	3					40	7	15	1.34
SPZ90-3	90	94	3					40	7	15	1.57
SPZ95-3	95	99	3					40	7	15	1.75
SPZ100-3	100	104	3					40	7	15	1.95
SPZ106-3	106	110	3					40	7	15	2.23
SPZ112-3	112	116	3					40	7	15	2.50
SPZ118-3	118	122	3					40	7	15	2.82
SPZ125-3	125	129	3					40	7	15	3.18
SPZ132-3	132	136	3	60	40	106	8	40	8	15	2.19
SPZ140-3	140	144	3	60	40	114	8	40	8	15	2.33
SPZ150-3	150	154	3	60	40	124	8	40	8	20	2.51
SPZ160-3	160	164	3	65	45	134	8	40	3	20	2.70
SPZ170-3	170	174	3	65	45	144	8	40	3	20	2.86
SPZ180-3	180	184	3	65	45	154	8	40	5	20	3.00
SPZ190-3	190	194	3	65	45	164	10	40	5	20	3.10
SPZ200-3	200	204	3	65	45	174	10	40	5	20	3.28
SPZ212-3	212	216	3	65	45	186	10	40	5	20	3.50
SPZ224-3	224	228	3	65	45	198	10	40	5	20	3.76
SPZ250-3	250	254	3	65	45	224	12	40	5	20	4.33
SPZ280-3	280	284	3	65	45	254	12	40	5	20	5.50
SPZ315-3	315	319	3	65	45	289	12	40	5	20	7.00
SPZ355-3	355	359	3	80	50	328	12	40	5	20	8.50
SPZ400-3	400	404	3	80	50	372	12	40	5	20	10.00

P.M SPA/1

P.M SPA(P.52-P.60)

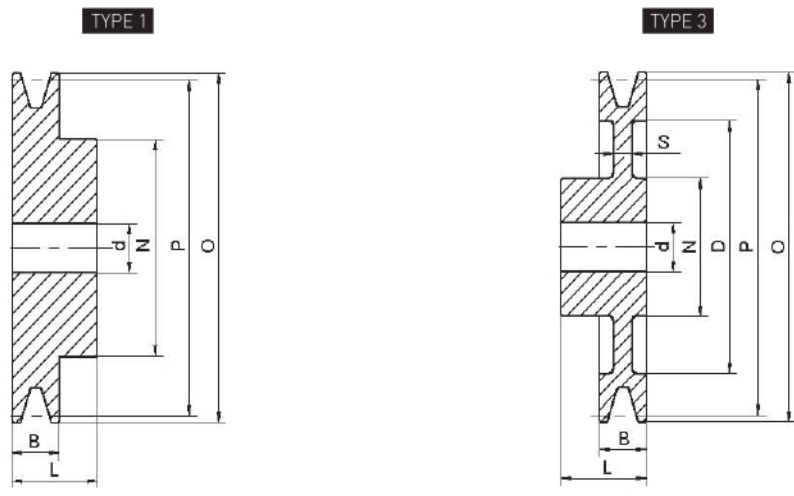

P.M SPA/1

Product Model	P	O	Grooves	N	L	D	S	B	TYPE	d (H9)	Weight (Kg)
SPA40-1	40	45,5	1	40	35			20	1	10	0.26
SPA50-1	50	55,5	1	40	35			20	1	10	0.35
SPA56-1	56	61,5	1	40	35			20	1	10	0.41
SPA60-1	60	65,5	1	40	35			20	1	10	0.46
SPA63-1	63	68,5	1	40	35			20	1	10	0.49
SPA67-1	67	72,5	1	40	40			20	1	10	0.55
SPA70-1	70	75,5	1	40	40			20	1	10	0.68
SPA71-1	71	76,5	1	40	40			20	1	10	0.65
SPA75-1	75	80,5	1	40	40			20	1	10	0.70
SPA80-1	80	85,5	1	45	40			20	1	10	0.84
SPA85-1	85	90,5	1	45	40			20	1	10	0.92
SPA90-1	90	95,5	1	45	40			20	1	10	1.02
SPA95-1	95	100,5	1	45	40			20	1	10	1.11
SPA100-1	100	105,5	1	48	40			20	1	10	1.25
SPA106-1	106	111,5	1	48	40			20	1	10	1.37
SPA112-1	112	117,5	1	48	40			20	1	10	1.55
SPA118-1	118	123,5	1	60	40			20	1	15	1.76
SPA120-1	120	125,5	1	60	40			20	1	15	1.86
SPA125-1	125	130,5	1	60	40			20	1	15	2.06
SPA130-1	130	135,5	1	60	40			20	1	15	2.12
SPA132-1	132	137,5	1	60	40			20	1	15	2.20
SPA140-1	140	145,5	1	60	40	107	10	20	3	15	1.98
SPA150-1	150	155,5	1	60	40	117	10	20	3	15	2.18
SPA160-1	160	165,5	1	60	40	127	10	20	3	15	2.36
SPA170-1	170	175,5	1	60	40	137	10	20	3	15	2.57
SPA180-1	180	185,5	1	65	40	147	10	20	3	20	2.85
SPA190-1	190	195,5	1	65	40	157	10	20	3	20	2.31
SPA200-1	200	205,5	1	65	45	167	10	20	3	20	3.45
SPA212-1	212	217,5	1	65	40	179	10	20	3	20	3.62
SPA224-1	224	229,5	1	65	45	192	10	20	3	20	4.00
SPA225-1	225	230,5	1	65	45	193	10	20	3	20	4.07

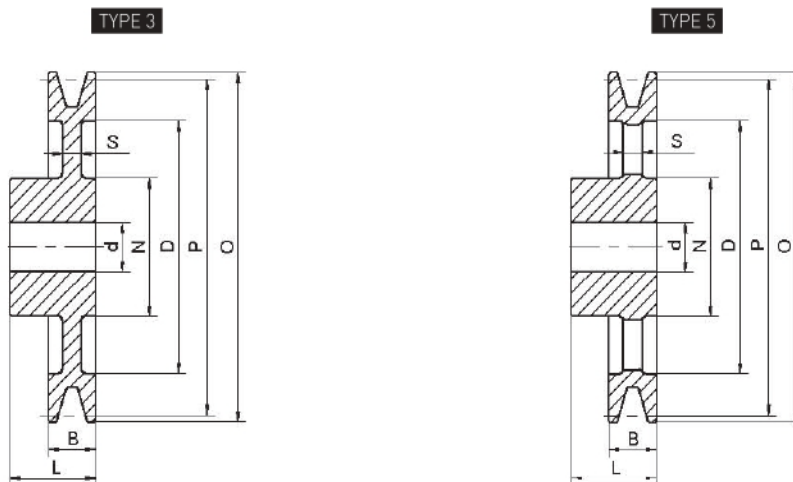

P.M SPA/1

Product Model	P	O	Grooves	N	L	D	S	B	TYPE	d (H9)	Weight (Kg)
SPA236-1	236	241.5	1	70	45	204	12	20	3	20	4.83
SPA250-1	250	255.5	1	75	50	217	12	20	3	20	5.69
SPA280-1	280	285.5	1	75	50	247	14	20	5	20	4.46
SPA300-1	300	305.5	1	75	50	267	14	20	5	20	4.99
SPA315-1	315	320.5	1	75	50	282	14	20	5	20	5.55
SPA355-1	355	360.5	1	75	50	322	14	20	5	20	6.50
SPA400-1	400	405.5	1	90	50	367	14	20	5	20	8.50
SPA450-1	450	455.5	1	90	50	417	14	20	5	20	9.40
SPA500-1	500	505.5	1	90	50	467	14	20	5	20	10.50
SPA560-1	560	565.5	1	100	50	527	15	20	5	25	12.70
SPA600-1	600	605.5	1	100	50	567	16	20	5	25	14.35
SPA630-1	630	635.5	1	100	50	597	16	20	5	25	13.50

P.M SPA/2

P.M SPA(P.52~P.60)

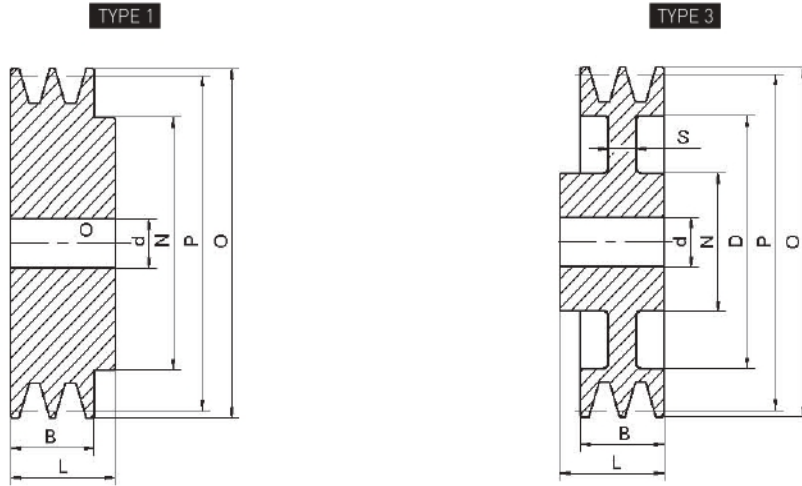

P.M SPA/2

Product Model	P	O	Grooves	N	L	D	S	B	TYPE	d (H9)	Weight (Kg)
SPA50-2	50	55,5	2	40	45			35	1	10	0.44
SPA56-2	56	61.5	2	40	45			35	1	10	0.55
SPA60-2	60	65.5	2	40	45			35	1	10	0.60
SPA63-2	63	68.5	2	40	45			35	1	10	0.68
SPA65-2	65	70.5	2	40	45			35	1	10	0.74
SPA67-2	67	72.5	2	40	45			35	1	10	0.78
SPA70-2	70	75.5	2	50	45			35	1	10	0.91
SPA71-2	71	76,5	2	50	45			35	1	10	0.93
SPA75-2	75	80,5	2	50	45			35	1	10	1.05
SPA80-2	80	85,5	2	50	45			35	1	10	1.17
SPA85-2	85	90.5	2	50	45			35	1	10	1.32
SPA90-2	90	95,5	2	60	45			35	1	15	1.50
SPA95-2	95	100,5	2	60	45			35	1	15	1.67
SPA100-2	100	105,5	2	60	45			35	1	15	1.84
SPA106-2	106	111,5	2	60	45			35	1	15	2.07
SPA112-2	112	117,5	2	60	45			35	1	15	2.30
SPA118-2	118	123,5	2	60	45			35	1	15	2.56
SPA120-2	120	125.5	2	60	45			35	1	15	2.68
SPA125-2	125	130.5	2	60	45			35	1	15	2.94
SPA132-2	132	137,5	2	60	45			35	1	15	3.25
SPA140-2	140	145,5	2	60	45	107	10	35	3	15	2.57
SPA150-2	150	155,5	2	60	45	117	10	35	3	15	2.80
SPA160-2	160	165,5	2	60	45	127	10	35	3	15	3.02
SPA170-2	170	175,5	2	60	45	137	10	35	3	15	3.30
SPA180-2	180	185,5	2	70	50	147	12	35	3	20	4.07
SPA190-2	190	195.5	2	70	50	157	12	35	3	20	4.40
SPA200-2	200	205,5	2	70	50	167	12	35	3	20	4.74
SPA212-2	212	217.5	2	70	50	179	12	35	3	20	5.06
SPA224-2	224	229,5	2	70	50	192	12	35	3	20	5.49
SPA225-2	225	230.5	2	70	50	193	12	35	3	20	5.54
SPA236-2	236	241.5	2	70	50	204	12	35	3	20	5.89

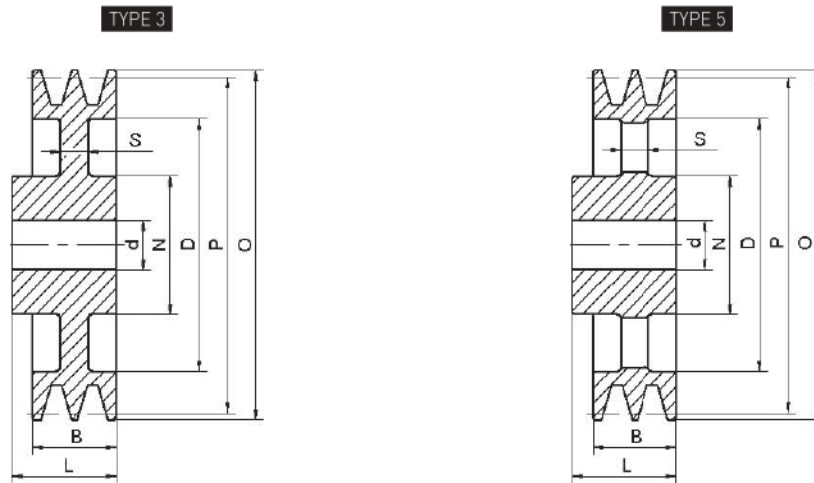

P.M SPA/2

Product Model	P	O	Grooves	N	L	D	S	B	TYPE	d (H9)	Weight (Kg)
SPA250-2	250	255,5	2	75	50	217	12	35	3	20	6.60
SPA280-2	280	285.5	2	80	50	247	14	35	5	20	5.92
SPA300-2	300	305.5	2	80	50	267	14	35	5	20	6.48
SPA315-2	315	320.5	2	80	50	282	14	35	5	20	6.94
SPA355-2	355	360.5	2	80	50	322	14	35	5	20	8.30
SPA400-2	400	405.5	2	90	50	367	14	35	5	20	10.50
SPA450-2	450	455.5	2	100	50	417	14	35	5	25	12.00
SPA500-2	500	505.5	2	100	50	467	16	35	5	25	14.00
SPA560-2	560	565.5	2	100	50	527	18	35	5	25	16.00
SPA630-2	630	635.5	2	110	50	597	18	35	5	25	21.00

P.M SPA/3

P.M SPA(P.52-P.60)

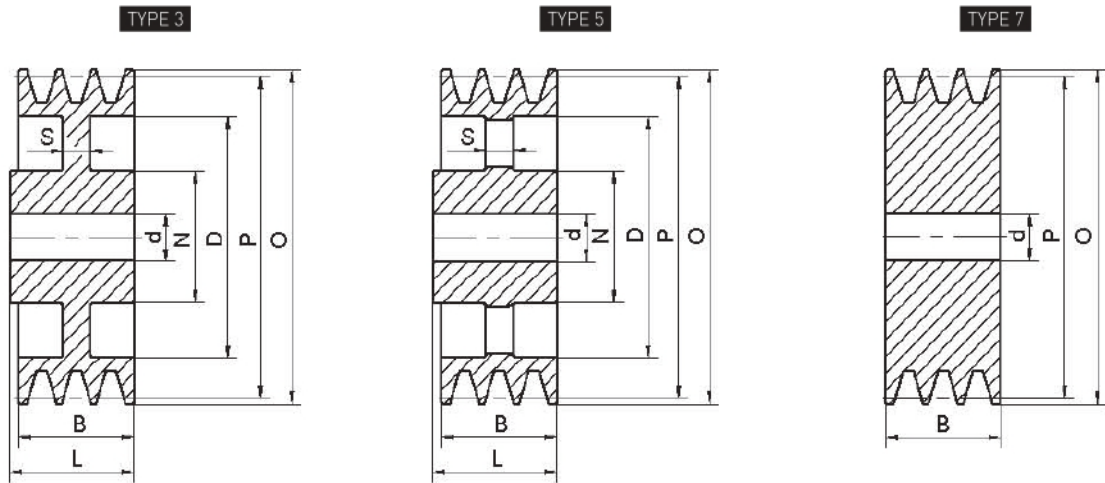

P.M SPA/3

Product Model	P	O	Grooves	N	L	D	S	B	TYPE	d (H9)	Weight (Kg)
SPA50-3	50	55.5	3					50	7	10	0.49
SPA56-3	56	61.5	3					50	7	10	0.64
SPA60-3	60	65.5	3					50	7	10	0.75
SPA63-3	63	68.5	3					50	7	10	0.84
SPA65-3	65	70.5	3					50	7	10	0.91
SPA67-3	67	72.5	3					50	7	10	1.00
SPA70-3	70	75.5	3					50	7	10	1.08
SPA71-3	71	76.5	3					50	7	10	1.10
SPA75-3	75	80.5	3					50	7	10	1.24
SPA80-3	80	85.5	3					50	7	15	1.41
SPA85-3	85	90.5	3					50	7	15	1.62
SPA90-3	90	95.5	3					50	7	15	1.84
SPA95-3	95	100.5	3					50	7	15	2.07
SPA100-3	100	105.5	3					50	7	15	2.32
SPA106-3	106	111.5	3					50	7	15	2.64
SPA112-3	112	117.5	3					50	7	15	3.02
SPA118-3	118	123.5	3					50	7	15	3.34
SPA120-3	120	125.5	3					50	7	15	3.50
SPA125-3	125	130.5	3					50	7	15	3.88
SPA132-3	132	137.5	3					50	7	15	4.33
SPA140-3	140	145.5	3	65	52	107	18	50	3	20	3.60
SPA150-3	150	155.5	3	65	52	117	18	50	3	20	3.95
SPA160-3	160	165.5	3	70	52	127	18	50	3	20	4.45
SPA170-3	170	175.5	3	70	52	137	18	50	3	20	4.94
SPA180-3	180	185.5	3	70	52	147	12	50	3	20	4.72
SPA190-3	190	195.5	3	70	52	157	12	50	3	20	5.10
SPA200-3	200	205.5	3	70	52	167	12	50	3	20	5.42
SPA224-3	224	229.5	3	80	52	192	12	50	3	20	6.66
SPA225-3	225	230.5	3	80	52	193	12	50	3	20	6.72
SPA230-3	230	241.5	3	80	52	204	12	50	3	20	7.20
SPA250-3	250	255.5	3	80	60	217	12	50	3	20	8.11
SPA280-3	280	285.5	3	80	60	247	14	50	5	20	7.30

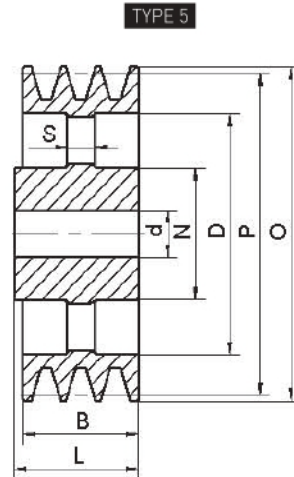

P.M SPA/3

Product Model	P	O	Grooves	N	L	D	S	B	TYPE	d (H9)	Weight (Kg)
SPA300-3	300	305,5	3	80	60	267	14	50	5	20	7.96
SPA315-3	315	320,5	3	90	60	282	14	50	5	20	8.92
SPA355-3	355	360,5	3	90	60	322	14	50	5	20	11.00
SPA400-3	400	405,5	3	100	60	367	16	50	5	25	13.00
SPA450-3	450	455,5	3	100	60	417	16	50	5	25	15.00
SPA500-3	500	505,5	3	105	60	467	20	50	5	25	18.60
SPA560-3	560	565,5	3	120	65	527	20	50	5	25	23.00
SPA630-3	630	635,5	3	120	65	597	20	50	5	25	26.70

P.M SPA/4

P.M SPA(P.52-P.60)

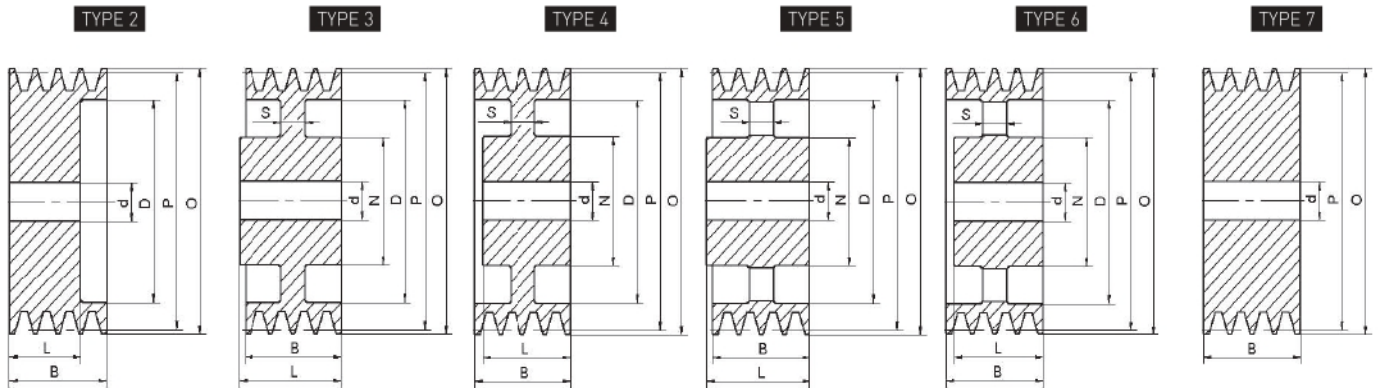

P.M SPA/4

Product Model	P	O	Grooves	N	L	D	S	B	TYPE	d (H9)	Weight (Kg)
SPA63-4	63	68.5	4					65	7	10	1.07
SPA71-4	71	76.5	4					65	7	10	1.42
SPA75-4	75	80.5	4					65	7	10	1.58
SPA80-4	80	85.5	4					65	7	15	1.81
SPA85-4	85	90.5	4					65	7	15	2.08
SPA90-4	90	95.5	4					65	7	15	2.38
SPA95-4	95	100.5	4					65	7	15	2.67
SPA100-4	100	105.5	4		52	67		65	2	15	2.67
SPA112-4	112	117.5	4		52	79		65	2	15	3.60
SPA118-4	118	123.5	4		52	87		65	2	15	3.76
SPA125-4	125	130.5	4		52	97		65	2	15	4.29
SPA132-4	132	137.5	4		52	97		65	2	15	4.95
SPA140-4	140	145.5	4		52	107		65	2	20	5.50
SPA150-4	150	155.5	4		52	117		65	2	20	6.29
SPA160-4	160	165.5	4	70	52	127	18	65	4	20	5.33
SPA170-4	170	175.5	4	80	52	137	18	65	4	20	5.79
SPA180-4	180	185.5	4	80	60	147	18	65	4	20	6.93
SPA190-4	190	195.5	4	80	60	157	18	65	4	20	7.07
SPA200-4	200	205.5	4	80	60	167	18	65	4	20	7.55
SPA212-4	212	217.5	4	80	60	179	18	65	4	20	8.20
SPA224-4	224	229.5	4	90	60	192	18	65	4	20	9.10
SPA236-4	236	241.5	4	90	60	203	18	65	4	20	10.00
SPA250-4	250	255.5	4	90	65	217	18	65	3	20	11.08
SPA280-4	280	285.5	4	90	65	247	16	65	5	20	9.55
SPA300-4	300	305.5	4	90	65	267	16	65	5	20	10.22
SPA315-4	315	320.5	4	90	65	282	16	65	5	20	10.73
SPA355-4	355	360.5	4	90	65	322	16	65	5	25	12.67
SPA400-4	400	405.5	4	100	65	367	20	65	5	25	16.40
SPA450-4	450	455.5	4	105	65	417	20	65	6	25	18.00
SPA500-4	500	505.5	4	105	65	467	20	65	6	25	16.10
SPA560-4	560	565.5	4	120	65	527	22	65	5	25	26.50
SPA630-4	630	635.5	4	120	65	597	22	65	5	25	35.00

P.M SPA/5

PILOT BORED V-BELT PULLEYS
 ● P.M SPA/4
 ● P.M SPA/5

PILOT BORED V-BELT PULLEYS

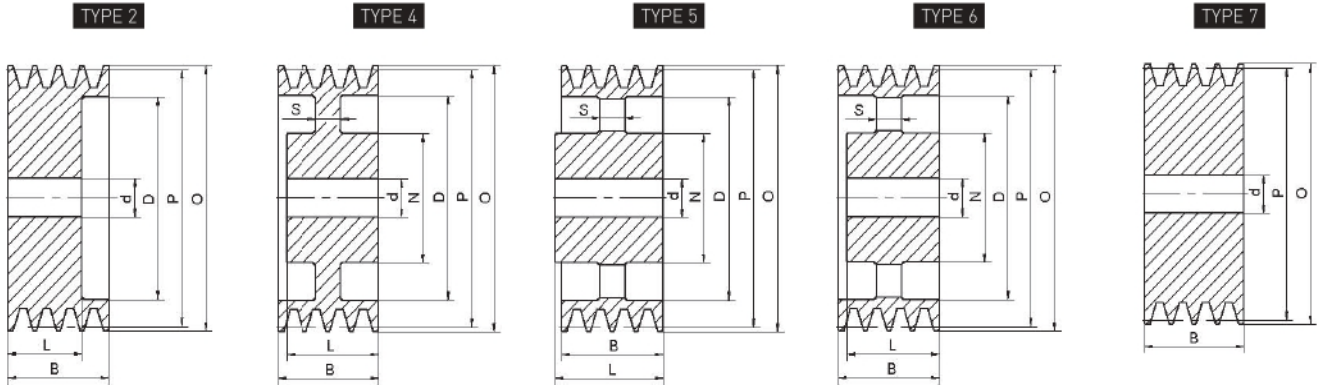

P.M SPA/5

Product Model	P	O	Grooves	N	L	D	S	B	TYPE	d (H9)	Weight (Kg)
SPA63-5	63	68.5	5					80	7	10	1.00
SPA71-5	71	76.5	5					80	7	10	1.70
SPA75-5	75	80.5	5					80	7	10	2.20
SPA80-5	80	85.5	5					80	7	15	2.23
SPA85-5	85	90.5	5					80	7	15	2.55
SPA90-5	90	95.5	5					80	7	15	2.91
SPA95-5	95	100.5	5					80	7	15	2.94
SPA100-5	100	105.5	5		52	67		80	2	15	2.97
SPA112-5	112	117.5	5		52	79		80	2	15	3.77
SPA118-5	118	123.5	5		52	87		80	2	15	4.30
SPA125-5	125	130.5	5		52	92		80	2	15	4.78
SPA132-5	132	137.5	5		52	97		80	2	15	5.45
SPA140-5	140	145.5	5		52	107		80	2	20	6.30
SPA150-5	150	155.5	5		52	117		80	2	20	6.84
SPA160-5	160	165.5	5	80	52	127	22	80	4	20	6.12
SPA170-5	170	175.5	5	80	52	137	18	80	4	20	6.80
SPA180-5	180	185.5	5	80	65	147	22	80	4	20	7.70
SPA190-5	190	195.5	5	80	65	157	20	80	4	20	8.30
SPA200-5	200	205.5	5	80	65	167	20	80	4	20	8.72
SPA212-5	212	217.5	5	80	65	179	20	80	4	20	9.50
SPA224-5	224	229.5	5	90	65	192	20	80	4	20	10.50
SPA236-5	236	241.5	5	90	65	203	20	80	4	20	11.00
SPA250-5	250	255.5	5	90	65	217	20	80	4	20	11.50
SPA280-5	280	285.5	5	100	65	247	18	80	6	25	12.00
SPA300-5	300	305.5	5	100	65	267	18	80	6	25	12.24
SPA315-5	315	320.5	5	100	65	282	18	80	6	25	13.10
SPA355-5	355	360.5	5	100	65	322	18	80	6	25	15.20
SPA400-5	400	405.5	5	100	65	367	22	80	6	25	18.00
SPA450-5	450	455.5	5	105	65	417	22	80	6	25	21.40
SPA500-5	500	505.5	5	110	65	467	22	80	6	25	24.60
SPA560-5	560	565.5	5	120	80	527	24	80	5	25	28.00
SPA600-5	600	605.5	5	120	80	567	26	80	5	25	32.00
SPA630-5	630	635.5	5	120	80	597	24	80	5	25	35.00

P.M SPA/6

P.M SPA(P.52-P.60)

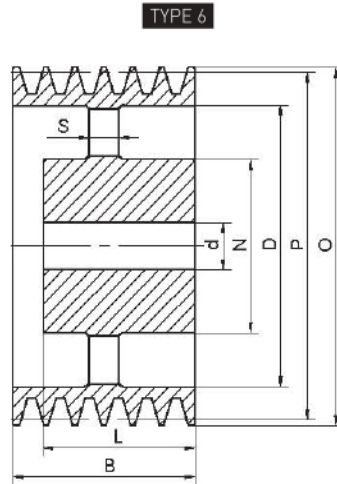

P.M SPA/6

Product Model	P	O	Grooves	N	L	D	S	B	TYPE	d (H9)	Weight (Kg)
SPA560-6	560	565.5	6	120	80	527	26	95	6	25	32.00
SPA600-6	600	605.5	6	120	80	567	26	95	6	25	34.00
SPA630-6	630	635.5	6	120	80	597	26	95	6	25	36.00

PILOT BORED V-BELT PULLEYS
 ● P.M SPA/6
 ● P.M SPB/1

P.M SPB/1

P.M SPB(P.61~P.69)

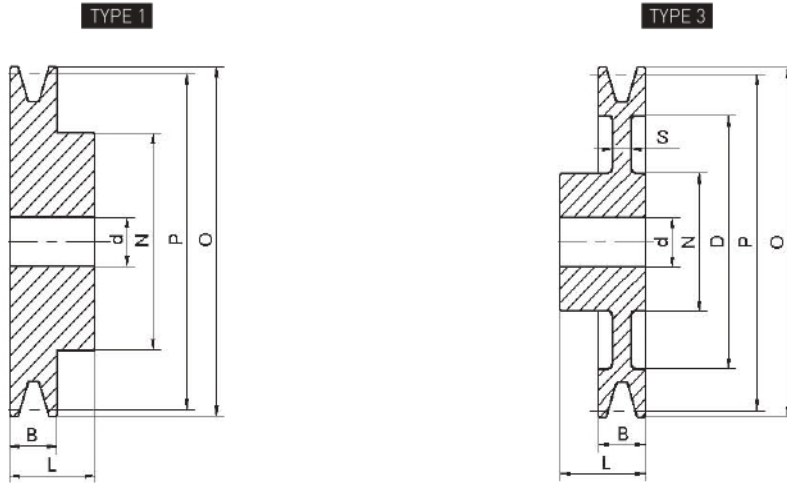

P.M SPB/1

Product Model	P	O	Grooves	N	L	D	S	B	TYPE	d (H9)	Weight (Kg)
SPB56-1	56	63	1	45	45			25	1	10	0.55
SPB60-1	60	67	1	45	45			25	1	10	0.60
SPB63-1	63	70	1	45	45			25	1	10	0.65
SPB65-1	65	72	1	45	45			25	1	10	0.69
SPB70-1	70	77	1	45	45			25	1	10	0.77
SPB71-1	71	78	1	45	45			25	1	10	0.78
SPB75-1	75	82	1	45	45			25	1	10	0.86
SPB80-1	80	87	1	50	45			25	1	10	1.01
SPB85-1	85	92	1	50	45			25	1	10	1.10
SPB90-1	90	97	1	50	45			25	1	10	1.24
SPB95-1	95	102	1	50	45			25	1	10	1.37
SPB100-1	100	107	1	52	45			25	1	10	1.48
SPB106-1	106	113	1	52	45			25	1	15	1.83
SPB112-1	112	119	1	55	45			25	1	15	1.83
SPB118-1	118	125	1	55	45			25	1	15	2.00
SPB120-1	120	127	1	55	45			25	1	15	2.06
SPB125-1	125	132	1	58	45			25	1	15	2.26
SPB130-1	130	137	1	60	45			25	1	15	2.46
SPB132-1	132	139	1	60	45			25	1	15	2.55
SPB140-1	140	147	1	65	45			25	1	20	2.84
SPB150-1	150	157	1	65	45			25	1	20	3.21
SPB160-1	160	167	1	65	45	118	12	25	3	20	2.93
SPB170-1	170	177	1	65	45	128	12	25	3	20	3.25
SPB180-1	180	187	1	65	45	138	12	25	3	20	3.48
SPB190-1	190	197	1	65	45	148	12	25	3	20	3.77
SPB200-1	200	207	1	70	45	158	14	25	3	20	4.47
SPB212-1	212	219	1	70	45	170	14	25	3	20	4.89
SPB224-1	224	231	1	70	45	183	14	25	3	20	5.28
SPB225-1	225	232	1	70	45	184	14	25	3	20	5.25
SPB230-1	230	237	1	70	45	188	14	25	3	20	6.00
SPB250-1	250	257	1	70	50	208	14	25	3	20	6.52
SPB280-1	280	287	1	76	50	238	14	25	3	20	8.08

P.M SPB/1

P.M SPB(P.61-P.69)

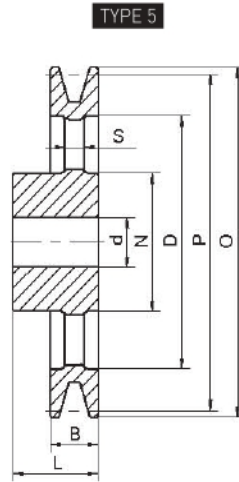

P.M SPB/1

Product Model	P	O	Grooves	N	L	D	S	B	TYPE	d (H9)	Weight (Kg)
SPB300-1	300	307	1	76	50	258	15	25	5	20	5.98
SPB315-1	315	322	1	76	50	273	15	25	5	20	6.25
SPB355-1	355	362	1	80	50	313	15	25	5	20	7.85
SPB400-1	400	407	1	85	55	358	18	25	5	20	10.50
SPB450-1	450	457	1	90	60	408	18	25	5	20	12.80
SPB500-1	500	507	1	100	60	458	18	25	5	25	14.10
SPB560-1	560	567	1	100	60	518	18	25	5	25	17.00
SPB600-1	600	607	1	100	60	558	18	25	5	25	17.75
SPB630-1	630	637	1	100	60	588	18	25	5	25	19.85

PILOT BORED V-BELT PULLEYS
 ● P.M SPB/1
 ● P.M SPB/2

P.M SPB/2

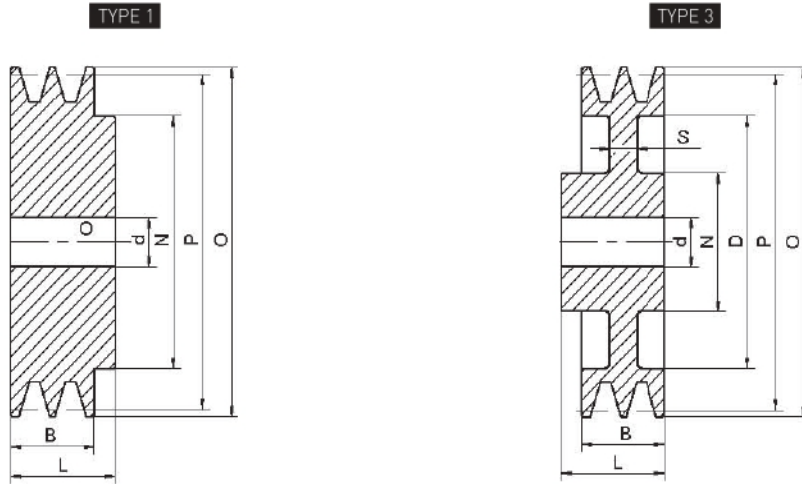

P.M SPB/2

Product Model	P	O	Grooves	N	L	D	S	B	TYPE	d (H9)	Weight (Kg)
SPB54-2	56	63	2	45	55			44	1	10	0.62
SPB60-2	60	67	2	45	55			44	1	10	0.74
SPB63-2	63	70	2	45	55			44	1	10	0.84
SPB65-2	65	72	2	45	55			44	1	10	0.88
SPB70-2	70	77	2	45	55			44	1	10	1.03
SPB71-2	71	78	2	45	55			44	1	10	1.06
SPB75-2	75	82	2	45	55			44	1	10	1.18
SPB80-2	80	87	2	50	55			44	1	10	1.37
SPB85-2	85	92	2	50	55			44	1	10	1.54
SPB90-2	90	97	2	50	55			44	1	10	1.73
SPB95-2	95	102	2	55	55			44	1	15	1.95
SPB100-2	100	107	2	55	55			44	1	15	2.17
SPB106-2	106	113	2	55	55			44	1	15	2.45
SPB112-2	112	119	2	60	55			44	1	15	2.77
SPB118-2	118	125	2	60	55			44	1	15	3.07
SPB120-2	120	127	2	60	55			44	1	15	3.16
SPB125-2	125	132	2	60	55			44	1	15	3.47
SPB130-2	130	137	2	60	55			44	1	15	3.75
SPB132-2	132	139	2	60	55			44	1	15	3.88
SPB140-2	140	147	2	65	55			44	1	20	4.36
SPB150-2	150	157	2	65	55			44	1	20	4.99
SPB160-2	160	167	2	70	55	118	12	44	3	20	4.19
SPB170-2	170	177	2	70	55	128	12	44	3	20	4.48
SPB180-2	180	187	2	70	55	138	12	44	3	20	4.82
SPB190-2	190	197	2	70	55	148	12	44	3	20	7.88
SPB200-2	200	207	2	70	55	158	12	44	3	20	5.66
SPB212-2	212	219	2	77	55	170	14	44	3	20	6.58
SPB224-2	224	231	2	77	55	183	14	44	3	20	7.03
SPB225-2	225	232	2	77	55	184	14	44	3	20	7.07
SPB236-2	236	243		77	55	194	14	44	3	20	8.40
SPB240-2	240	247	2	77	55	198	14	44	3	20	7.92
SPB250-2	250	257	2	77	55	208	14	44	3	20	8.30

P.M SPB/2

P.M SPB(P.61-P.69)

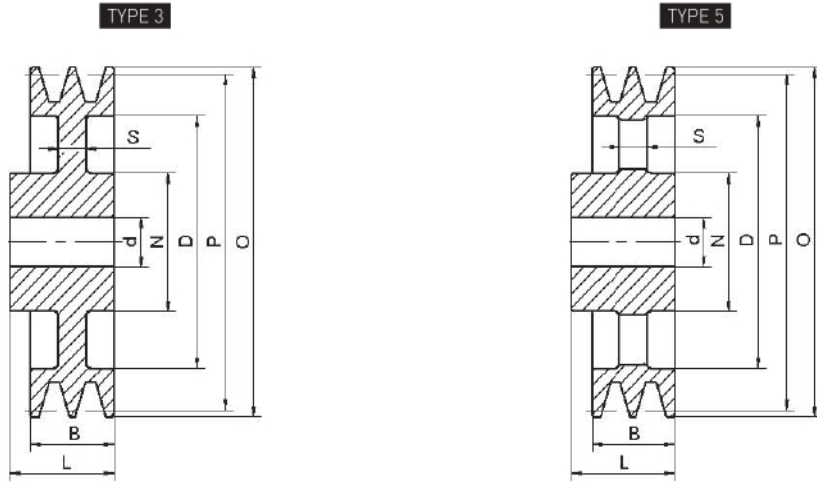

P.M SPB/2

Product Model	P	O	Grooves	N	L	D	S	B	TYPE	d (H9)	Weight (Kg)
SPB260-2	260	267	2	77	55	218	14	44	3	20	8.80
SPB280-2	280	287	2	80	55	238	14	44	3	20	10.50
SPB300-2	300	307	2	80	55	258	15	44	5	20	8.20
SPB315-2	315	322	2	88	60	273	15	44	5	20	9.36
SPB355-2	355	362	2	88	60	313	15	44	5	20	10.72
SPB400-2	400	407	2	88	60	358	18	44	5	20	13.40
SPB450-2	450	457	2	90	60	408	18	44	5	20	14.20
SPB500-2	500	507	2	100	65	458	20	44	5	25	18.84
SPB560-2	560	567	2	100	65	518	20	44	5	25	22.00
SPB630-2	630	637	2	100	65	588	20	44	5	25	25.20

P.M SPB/3

PILOT BORED V-BELT PULLEYS
 ● P.M SPB/2
 ● P.M SPB/3

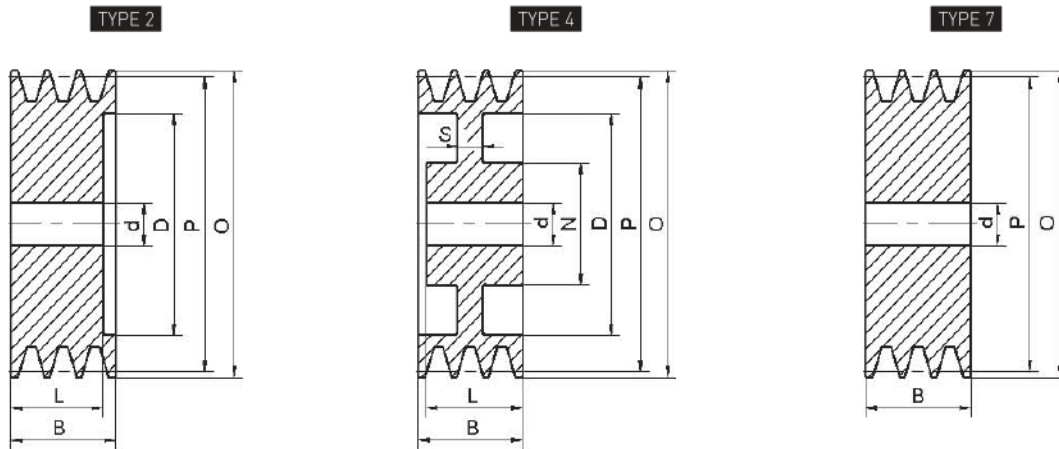

P.M SPB/3

Product Model	P	O	Grooves	N	L	D	S	B	TYPE	d (H9)	Weight (Kg)
SPB50-3	50	57	3					63	7	10	0.60
SPB56-3	56	63	3					63	7	10	0.80
SPB63-3	63	70	3					63	7	15	0.94
SPB70-3	70	77	3					63	7	15	1.21
SPB71-3	71	78	3					63	7	15	1.25
SPB75-3	75	82	3					63	7	15	1.43
SPB80-3	80	87	3					63	7	15	1.67
SPB85-3	85	92	3					63	7	15	1.94
SPB90-3	90	97	3					63	7	15	2.15
SPB95-3	95	102	3					63	7	15	2.47
SPB100-3	100	107	3					63	7	15	2.78
SPB106-3	106	113	3					63	7	15	3.17
SPB112-3	112	119	3					63	7	15	3.58
SPB118-3	118	125	3					63	7	15	4.03
SPB120-3	120	127	3					63	7	15	4.22
SPB125-3	125	132	3		60	83		63	2	15	4.47
SPB130-3	130	137	3		60	86		63	2	15	4.86
SPB132-3	132	139	3		60	88		63	2	15	5.03
SPB140-3	140	147	3		60	98		63	2	20	5.69
SPB150-3	150	157	3		60	108		63	2	20	6.60
SPB160-3	160	167	3		60	118		63	2	20	7.50
SPB170-3	170	177	3	70	60	128	30	63	4	20	6.67
SPB180-3	180	187	3	80	60	138	18	63	4	20	6.88
SPB190-3	190	197	3	80	60	148	18	63	4	20	6.28
SPB200-3	200	207	3	80	60	158	18	63	4	20	7.88
SPB212-3	212	219	3	80	60	170	18	63	4	20	8.63
SPB224-3	224	231	3	80	60	183	18	63	4	20	9.20
SPB225-3	225	232	3	80	60	184	18	63	4	20	9.31
SPB236-3	236	243	3	80	60	194	18	63	4	20	10.17
SPB240-3	240	247	3	80	60	198	18	63	4	20	10.26
SPB250-3	250	257	3	80	60	208	18	63	4	20	10.92

P.M SPB/3

P.M SPB(P.61-P.69)

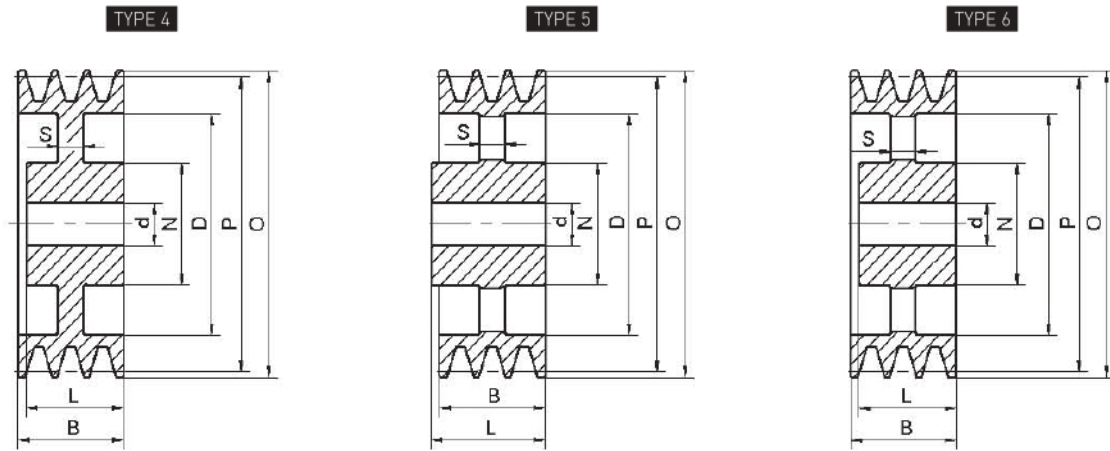

P.M SPB/3

Product Model	P	O	Grooves	N	L	D	S	B	TYPE	d (H9)	Weight (Kg)
SPB280-3	280	287	3	90	60	238	18	63	4	20	12.95
SPB300-3	300	307	3	90	60	258	18	63	6	20	11.21
SPB315-3	315	322	3	90	60	273	18	63	6	20	11.78
SPB335-3	335	342	3	92	60	293	18	63	6	25	14.00
SPB355-3	355	362	3	92	60	313	18	63	6	25	14.12
SPB375-3	375	382	3	92	60	333	18	63	6	25	14.70
SPB400-3	400	407	3	96	65	358	22	63	5	25	18.13
SPB425-3	425	432	3	96	65	383	22	63	5	20	22.30
SPB450-3	450	457	3	96	65	408	22	63	5	25	23.50
SPB500-3	500	507	3	104	75	458	24	63	5	25	25.30
SPB560-3	560	567	3	104	75	518	24	63	5	25	28.60
SPB600-3	600	607	3	104	75	558	24	63	5	25	32.00
SPB630-3	630	637	3	105	75	588	26	63	5	25	34.80

P.M SPB/4

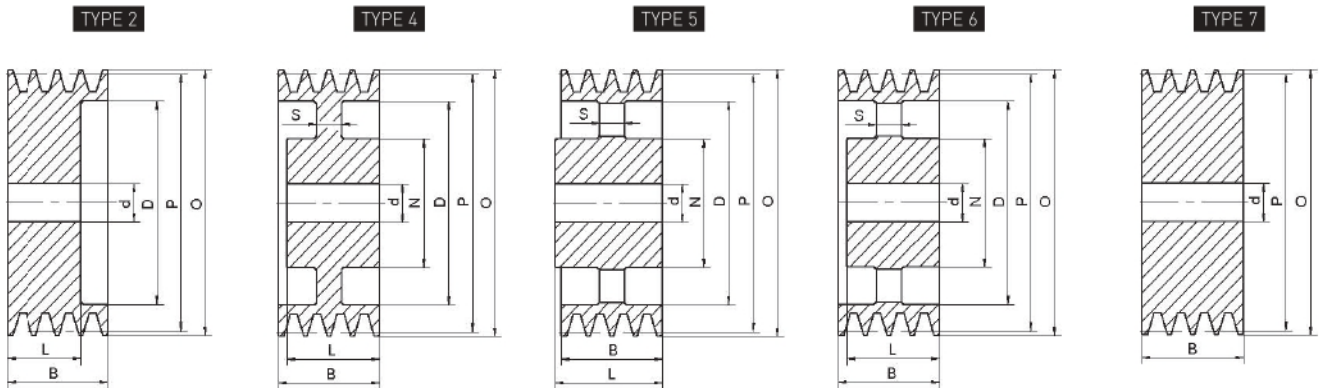

P.M SPB/4

Product Model	P	O	Grooves	N	L	D	S	B	TYPE	d (H9)	Weight (Kg)
SPB71-4	71	78	4					82	7	15	1.60
SPB80-4	80	87	4					82	7	15	2.10
SPB85-4	85	92	4					82	7	15	2.50
SPB90-4	90	97	4					82	7	15	2.80
SPB95-4	95	102	4					82	7	15	3.20
SPB100-4	100	107	4					82	7	15	3.60
SPB106-4	106	113	4					82	7	15	4.08
SPB112-4	112	119	4					82	7	20	4.57
SPB118-4	118	125	4					82	7	20	5.12
SPB120-4	120	127	4					82	7	20	5.30
SPB125-4	125	132	4		60	83		82	2	20	5.00
SPB132-4	132	139	4		60	88		82	2	20	5.66
SPB140-4	140	147	4		60	98		82	2	20	6.38
SPB150-4	150	157	4		60	108		82	2	20	7.31
SPB160-4	160	167	4		60	118		82	2	20	8.39
SPB170-4	170	177	4	70	60	128	30	82	4	20	7.51
SPB180-4	180	187	4	80	60	138	30	82	4	20	8.57
SPB200-4	200	207	4	88	60	158	25	82	4	20	10.06
SPB212-4	212	219	4	88	60	170	25	82	4	20	10.92
SPB224-4	224	231	4	88	60	183	25	82	4	20	11.77
SPB225-4	225	232	4	88	60	184	25	82	4	20	11.88
SPB236-4	236	243	4	88	60	194	25	82	4	20	12.50
SPB240-4	240	247	4	96	65	198	25	82	4	25	13.67
SPB250-4	250	257	4	96	65	208	25	82	4	25	14.46
SPB280-4	280	287	4	96	65	238	25	82	4	25	16.60
SPB300-4	300	307	4	96	65	258	20	82	6	25	13.67
SPB315-4	315	322	4	96	65	273	20	82	6	25	14.36
SPB335-4	335	342	4	96	65	293	20	82	6	25	19.89
SPB355-4	355	362	4	96	65	313	20	82	6	25	18.00
SPB400-4	400	407	4	104	75	358	24	82	6	25	22.00
SPB425-4	425	432	4	104	75	383	24	82	6	25	32.80
SPB450-4	450	457	4	104	75	408	24	82	6	25	24.90
SPB500-4	500	507	4	112	85	458	28	82	5	25	31.00
SPB560-4	560	567	4	112	85	518	28	82	5	25	36.00
SPB600-4	600	607	4	115	85	558	28	82	5	25	39.00
SPB630-4	630	637	4	120	85	588	28	82	5	25	41.00

P.M SPB/5

P.M SPB(P.61-P.69)

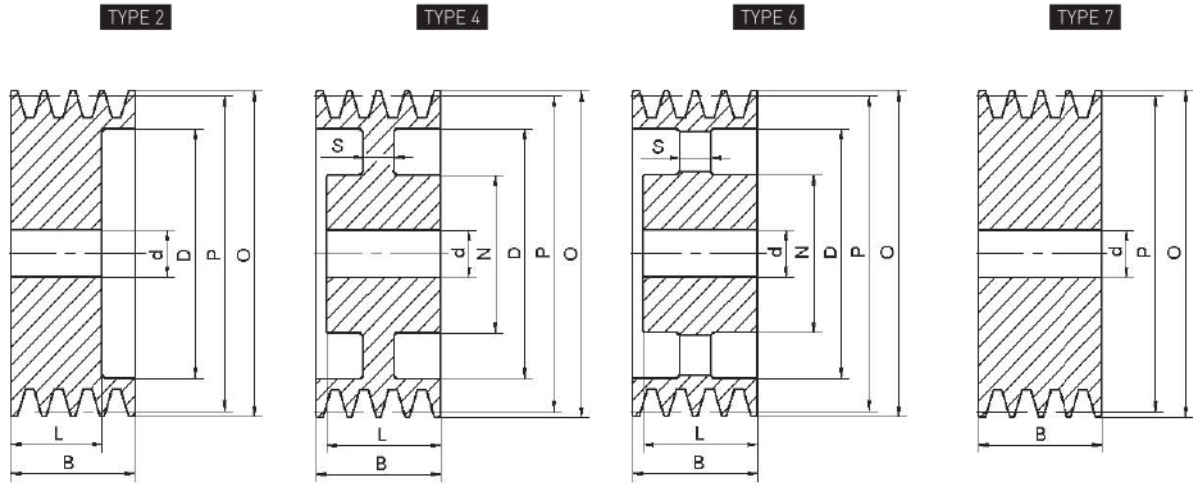

P.M SPB/5

Product Model	P	O	Grooves	N	L	D	S	B	TYPE	d (H9)	Weight (Kg)
SPB80-5	80	87	5					101	7	15	2.62
SPB85-5	85	92	5					101	7	15	3.00
SPB90-5	90	97	5					101	7	15	3.50
SPB95-5	95	102	5					101	7	15	3.90
SPB100-5	100	107	5					101	7	15	4.36
SPB106-5	106	113	5					101	7	20	5.10
SPB112-5	112	119	5					101	7	20	5.62
SPB118-5	118	125	5					101	7	20	6.32
SPB120-5	120	127	5					101	7	20	7.50
SPB125-5	125	132	5		60	83		101	2	20	5.70
SPB132-5	132	139	5		60	88		101	2	20	6.34
SPB140-5	140	147	5		60	98		101	2	20	7.02
SPB150-5	150	157	5		60	108		101	2	20	8.12
SPB160-5	160	167	5		60	118		101	2	20	9.25
SPB170-5	170	177	5	70	60	128	30	101	4	20	8.35
SPB180-5	180	187	5	80	70	138	30	101	4	20	10.56
SPB190-5	190	197	5	90	70	148	30	101	4	20	11.50
SPB200-5	200	207	5	96	70	158	30	101	4	25	12.76
SPB212-5	212	219	5	96	70	170	30	101	4	25	13.42
SPB224-5	224	231	5	96	70	183	25	101	4	25	13.75
SPB236-5	236	243	5	96	70	194	25	101	4	25	15.50
SPB250-5	250	257	5	104	75	208	25	101	4	25	16.85
SPB280-5	280	287	5	104	75	238	25	101	4	25	19.74
SPB300-5	300	307	5	104	75	258	22	101	6	25	16.93
SPB315-5	315	322	5	104	75	273	22	101	6	25	17.66
SPB335-5	335	342	5	104	75	313	22	101	6	25	22.48
SPB355-5	355	362	5	104	75	313	22	101	6	25	21.40
SPB400-5	400	407	5	112	85	358	26	101	6	25	26.30
SPB450-5	450	457	5	112	85	408	26	101	6	25	30.00
SPB500-5	500	507	5	120	90	458	30	101	6	25	35.00
SPB560-5	560	567	5	120	90	518	30	101	6	25	37.00
SPB600-5	600	607	5	120	90	558	30	101	6	25	42.00
SPB630-5	630	637	5	128	90	588	30	101	6	25	45.00

P.M SPB/6

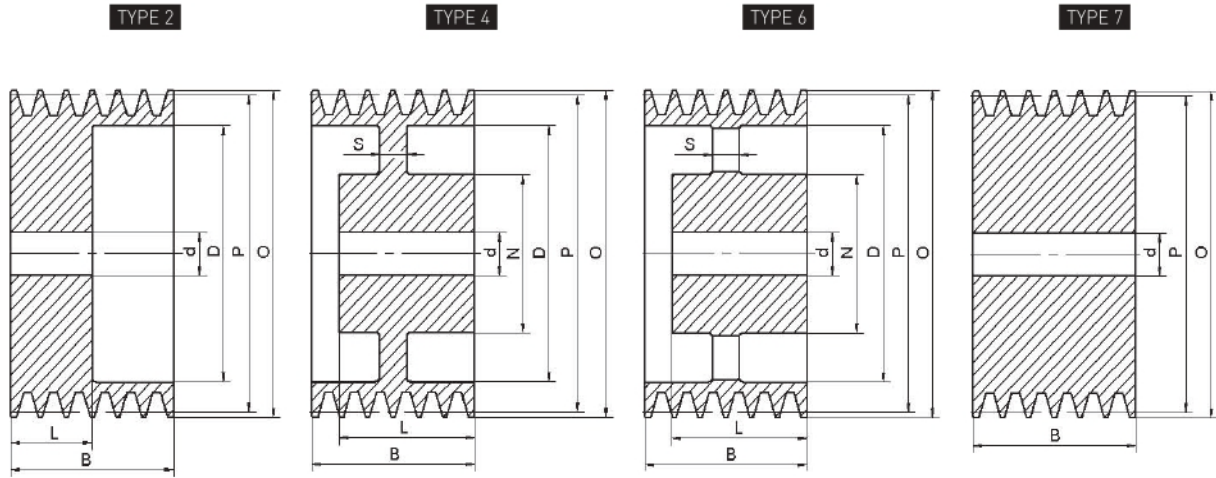

P.M SPB/6

Product Model	P	O	Grooves	N	L	D	S	B	TYPE	d (H9)	Weight (Kg)
SPB100-6	100	107	6					120	7	20	5.07
SPB106-6	106	113	6					120	7	20	5.80
SPB112-6	112	119	6					120	7	20	6.50
SPB118-6	118	125	6					120	7	20	7.39
SPB120-6	120	127	6					120	7	20	8.00
SPB125-6	125	132	6		60	83		120	2	20	6.24
SPB132-6	132	139	6		60	88		120	2	20	7.08
SPB140-6	140	147	6		60	98		120	2	20	8.00
SPB150-6	150	157	6		60	108		120	2	20	8.90
SPB160-6	160	167	6		65	118		120	2	20	10.38
SPB170-6	170	177	6	70	65	128	40	120	4	20	12.70
SPB180-6	180	187	6	80	70	138	40	120	4	20	12.99
SPB190-6	190	197	6	85	70	148	40	120	4	20	13.50
SPB200-6	200	207	6	96	70	158	40	120	4	25	14.29
SPB212-6	212	219	6	104	80	170	35	120	4	25	14.91
SPB224-6	224	231	6	104	80	183	30	120	4	25	16.65
SPB236-6	236	243	6	104	80	194	30	120	4	25	17.50
SPB250-6	250	257	6	104	80	208	25	120	4	25	18.82
SPB280-6	280	287	6	104	80	238	25	120	4	25	22.00
SPB300-6	300	307	6	104	80	258	24	120	6	25	21.00
SPB315-6	315	322	6	120	90	273	24	120	6	25	22.30
SPB355-6	355	362	6	120	90	313	24	120	6	25	24.95
SPB400-6	400	407	6	120	100	358	28	120	6	25	31.00
SPB450-6	450	457	6	120	100	408	28	120	6	25	36.00
SPB500-6	500	507	6	128	105	458	33	120	6	25	45.00
SPB560-6	560	567	6	128	105	518	33	120	6	25	47.00
SPB600-6	600	607	6	129	105	558	33	120	6	25	49.05
SPB630-6	630	637	6	140	105	588	33	120	6	25	53.00

P.M SPC/1

P.M SPC(P.70-P.75)

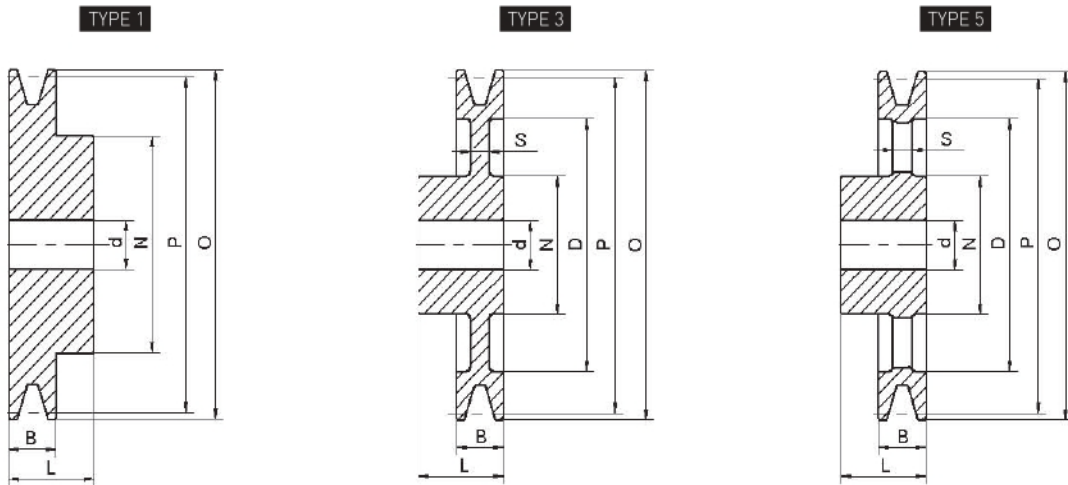

P.M SPC/1

Product Model	P	O	Grooves	N	L	D	S	B	TYPE	d (H9)	Weight (Kg)
SPC100-1	100	109.6	1	60	50			34	1	15	1.84
SPC110-1	110	119.6	1	60	50			34	1	15	2.00
SPC112-1	112	121.6	1	60	50			34	1	15	2.28
SPC118-1	118	127.6	1	60	50			34	1	15	2.54
SPC120-1	120	129.6	1	65	50			34	1	15	2.66
SPC125-1	125	134.6	1	65	50			34	1	15	2.84
SPC130-1	130	139.6	1	65	50			34	1	15	3.00
SPC132-1	132	141.6	1	65	50			34	1	15	3.18
SPC140-1	140	149.6	1	70	50			34	1	20	3.55
SPC150-1	150	159.6	1	70	50			34	1	20	4.09
SPC160-1	160	169.6	1	72	50			34	1	20	4.68
SPC170-1	170	179.6	1	72	50	113	16	34	3	20	5.58
SPC180-1	180	189.6	1	76	50	123	16	34	3	20	5.05
SPC190-1	190	196.6	1	76	50	133	16	34	3	20	5.50
SPC200-1	200	209.6	1	76	50	143	16	34	3	20	5.85
SPC220-1	220	229.6	1	86	50	164	16	34	3	20	7.04
SPC224-1	224	233.6	1	86	50	168	16	34	3	20	7.20
SPC230-1	230	239.6	1	86	50	174	16	34	3	20	7.12
SPC240-1	240	249.6	1	86	50	183	16	34	3	20	8.00
SPC250-1	250	259.6	1	86	50	193	16	34	3	20	8.51
SPC280-1	280	289.6	1	86	50	223	16	34	3	20	10.18
SPC300-1	300	309.6	1	86	50	243	16	34	3	20	11.76
SPC315-1	315	324.6	1	92	50	258	16	34	5	20	9.00
SPC335-1	335	344.6	1	100	50	283	16	34	5	20	10.00
SPC355-1	355	364.6	1	110	50	298	16	34	5	20	12.00
SPC400-1	400	409.6	1	110	60	343	18	34	5	25	14.00
SPC450-1	450	459.6	1	110	60	393	18	34	5	25	16.00
SPC500-1	500	509.6	1	114	60	443	18	34	5	25	18.50
SPC560-1	560	569.6	1	114	60	503	20	34	5	25	22.00
SPC600-1	600	609.6	1	114	60	543	20	34	5	25	24.00
SPC630-1	630	639.6	1	114	60	573	20	34	5	25	26.00

P.M SPC/2

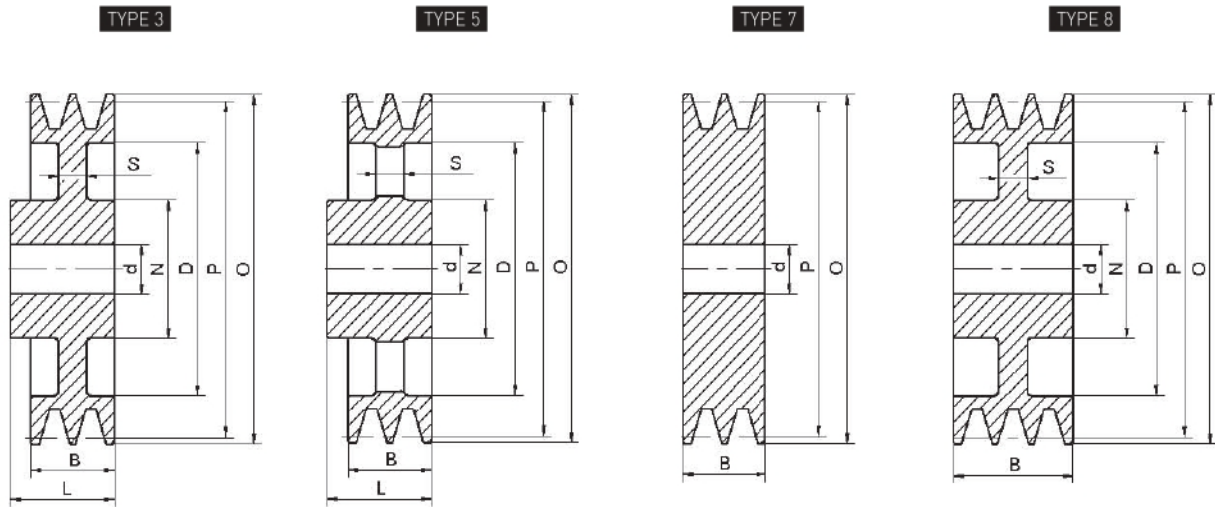

P.M SPC/2

Product Model	P	O	Grooves	N	L	D	S	B	TYPE	d (H9)	Weight (Kg)
SPC118-2	118	127.6	2					59,5	7	15	3.66
SPC120-2	120	129.6	2					59,5	7	15	3.90
SPC125-2	125	134.6	2					59,5	7	15	4.18
SPC130-2	130	139.6	2					59,5	7	15	4.50
SPC132-2	132	141.6	2					59,5	7	15	4.72
SPC140-2	140	149.6	2					59,5	7	20	5.30
SPC150-2	150	159.6	2					59,5	7	20	6.16
SPC160-2	160	169.6	2					59,5	7	20	7.13
SPC170-2	170	179.6	2	80		113	30	59,5	8	20	7.08
SPC180-2	180	189.6	2	80		123	30	59,5	8	20	7.82
SPC190-2	190	199.6	2	80		133	20	59,5	8	20	7.88
SPC200-2	200	209.6	2	80	60	143	20	59,5	3	20	9.71
SPC220-2	220	229.6	2	88	60	164	18	59,5	3	20	10.72
SPC224-2	224	233.6	2	88	60	168	18	59,5	3	20	10.03
SPC225-2	225	234.6	2	88	60	169	18	59,5	3	20	10.13
SPC240-2	240	249.6	2	92	60	183	18	59,5	3	20	11.24
SPC250-2	250	259.6	2	92	60	193	18	59,5	3	20	11.93
SPC280-2	280	289.6	2	92	60	223	18	59,5	3	20	14.18
SPC300-2	300	309.6	2	92	60	243	18	59,5	3	20	15.80
SPC315-2	315	324.6	2	92	60	258	18	59,5	5	20	13.10
SPC355-2	355	364.6	2	110	60	298	20	59,5	5	25	16.00
SPC400-2	400	409.6	2	110	70	343	20	59,5	5	25	20.50
SPC450-2	450	459.6	2	110	70	393	20	59,5	5	25	23.00
SPC500-2	500	509.6	2	114	70	443	20	59,5	5	25	25.00
SPC560-2	560	569.6	2	114	70	503	24	59,5	5	25	30.00
SPC600-2	600	609.6	2	114	70	543	24	59,5	5	25	33.00
SPC630-2	630	639.6	2	114	70	573	24	59,5	5	25	34.00

P.M SPC/3

P.M SPC(P.70-P.75)

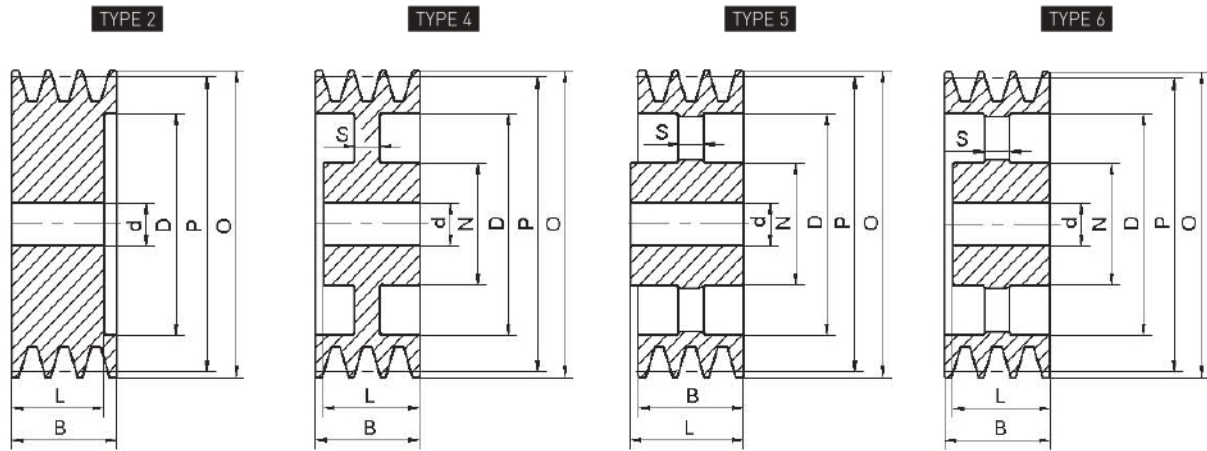

P.M SPC/3

Product Model	P	O	Grooves	N	L	D	S	B	TYPE	d (H9)	Weight (Kg)
SPC118-3	118	127.6	3		65	61		85	2	15	4.74
SPC125-3	125	134.6	3		65	68		85	2	15	5.36
SPC140-3	140	149.6	3		65	83		85	2	20	6.70
SPC150-3	150	159.6	3		65	93		85	2	20	7.65
SPC160-3	160	169.6	3		65	103		85	2	20	8.92
SPC170-3	170	179.6	3		65	113		85	2	20	9.50
SPC180-3	180	189.6	3	82	65	123	35	85	4	20	9.83
SPC190-3	190	196.6	3	82	65	133	25	85	4	20	10.26
SPC200-3	200	209.6	3	86	65	143	25	85	4	20	11.13
SPC224-3	224	233.6	3	90	70	168	21	85	4	20	12.90
SPC225-3	225	234.6	3	90	70	169	21	85	4	20	13.11
SPC250-3	250	259.6	3	92	70	193	21	85	4	20	15.31
SPC280-3	280	289.6	3	92	70	223	21	85	4	20	18.11
SPC300-3	300	309.6	3	92	70	243	21	85	4	20	20.00
SPC315-3	315	324.6	3	92	70	258	22	85	6	25	17.72
SPC335-3	335	344.6	3	100	70	283	22	85	6	25	21.00
SPC355-3	355	364.6	3	110	70	298	22	85	6	25	23.00
SPC400-3	400	409.6	3	114	90	343	24	85	5	25	28.80
SPC450-3	450	459.6	3	114	90	393	24	85	5	25	33.00
SPC500-3	500	509.6	3	114	90	443	24	85	5	25	36.00
SPC560-3	560	569.6	3	114	90	503	28	85	5	25	42.00
SPC600-3	600	609.6	3	114	90	543	28	85	5	25	47.00
SPC630-3	630	639.6	3	114	90	573	28	85	5	25	50.00

P.M SPC/4

PILOT BORED V-BELT PULLEYS
 ● P.M SPC/3
 ● P.M SPC/4

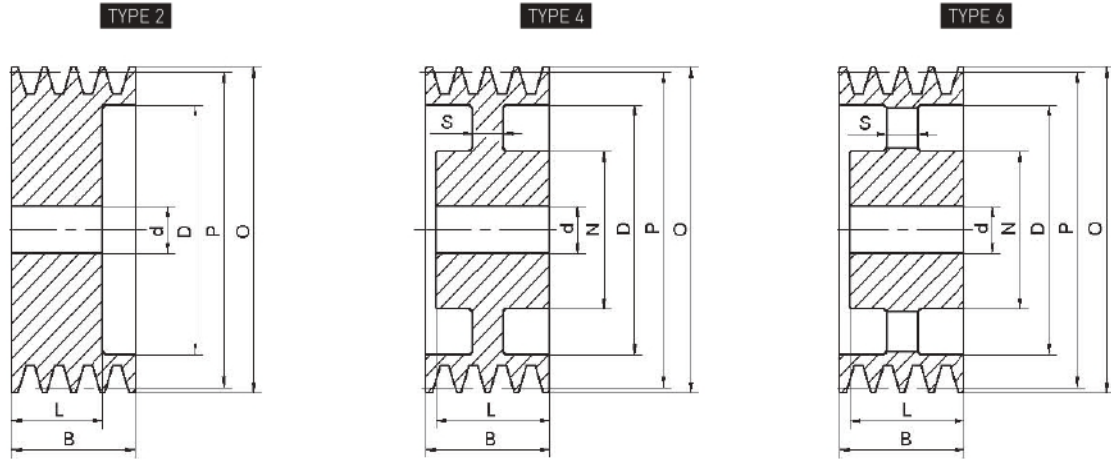

P.M SPC/4

Product Model	P	O	Grooves	N	L	D	S	B	TYPE	d (H9)	Weight (Kg)
SPC140-4	140	149.6	4		80	83		110,5	2	20	8.50
SPC150-4	150	159.6	4		80	93		110,5	2	20	9.76
SPC160-4	160	169.6	4		80	103		110,5	2	20	11.16
SPC170-4	170	179.6	4		80	113		110,5	2	20	12.50
SPC180-4	180	189.6	4	82	80	123	60	110,5	4	20	13.28
SPC190-4	190	196.6	4	86	80	133	60	110,5	4	20	15.00
SPC200-4	200	209.6	4	90	90	143	60	110,5	4	20	17.41
SPC224-4	224	233.6	4	90	90	168	50	110,5	4	25	19.15
SPC225-4	225	234.6	4	90	90	169	50	110,5	4	25	19.16
SPC250-4	250	259.6	4	100	90	193	30	110,5	4	25	20.48
SPC280-4	280	289.6	4	100	90	223	25	110,5	4	25	23.14
SPC300-4	300	309.6	4	100	90	243	25	110,5	4	25	25.50
SPC315-4	315	324.6	4	110	90	258	25	110,5	4	25	28.00
SPC335-4	335	344.6	4	114	90	283	25	110,5	6	25	28.50
SPC355-4	355	364.6	4	114	90	298	25	110,5	6	25	28.72
SPC400-4	400	409.6	4	114	90	343	26	110,5	6	25	34.00
SPC450-4	450	459.6	4	120	90	393	28	110,5	6	25	39.00
SPC500-4	500	509.6	4	126	90	443	28	110,5	6	25	43.96
SPC560-4	560	569.6	4	130	100	503	30	110,5	6	25	53.60
SPC600-4	600	609.6	4	130	90	543	30	110,5	6	25	55.50
SPC630-4	630	639.6	4	130	90	573	30	110,5	6	25	57.00

P.M SPC/5

P.M SPC(P.70-P.75)

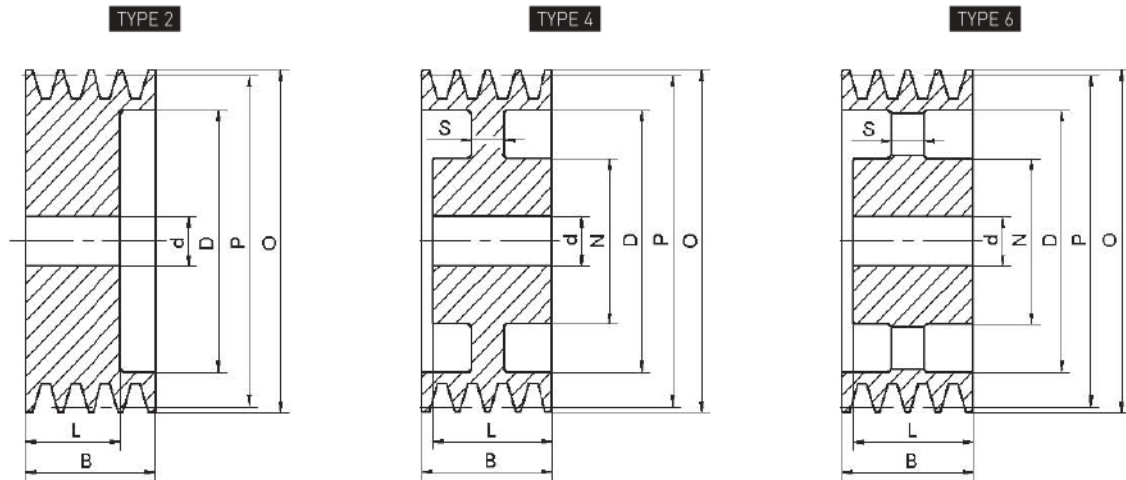

P.M SPC/5

Product Model	P	O	Grooves	N	L	D	S	B	TYPE	d (H9)	Weight (Kg)
SPC150-5	150	159.6	5		96	93		136	2	20	12.50
SPC160-5	160	169.6	5		96	103		136	2	20	14.50
SPC180-5	180	189.6	5	82	96	123	75	136	4	20	16.20
SPC200-5	200	209.6	5	90	100	143	80	136	4	25	20.23
SPC224-5	224	233.6	5	90	100	168	60	136	4	25	21.80
SPC225-5	225	234.6	5	90	100	169	60	136	4	25	22.86
SPC250-5	250	259.6	5	102	100	193	50	136	4	25	26.70
SPC265-5	265	274.6	5	102	100	208	40	136	4	25	27.80
SPC280-5	280	289.6	5	102	100	223	40	136	4	25	29.93
SPC300-5	300	309.6	5	104	100	243	25	136	4	25	28.40
SPC315-5	315	324.6	5	112	100	258	25	136	4	25	32.00
SPC335-5	335	344.6	5	114	100	283	28	136	6	25	33.50
SPC355-5	355	364.6	5	114	100	298	28	136	6	25	34.50
SPC400-5	400	409.6	5	120	100	343	28	136	6	25	39.50
SPC450-5	450	459.6	5	120	100	393	30	136	6	25	45.00
SPC500-5	500	509.6	5	126	100	443	30	136	6	25	51.00
SPC560-5	560	569.6	5	130	100	503	32	136	6	25	60.20
SPC600-5	600	609.6	5	130	100	543	32	136	6	25	64.00
SPC630-5	630	639.6	5	130	100	573	32	136	6	25	68.00

P.M SPC/6

PILOT BORED V-BELT PULLEYS
 ● P.M SPC/5
 ● P.M SPC/6

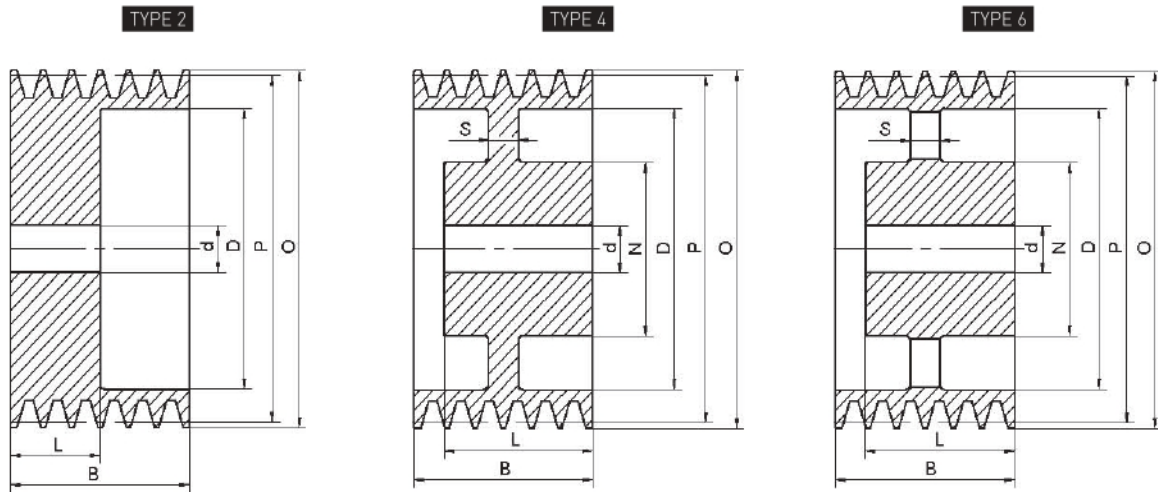

P.M SPC/6

Product Model	P	O	Grooves	N	L	D	S	B	TYPE	d (H9)	Weight (Kg)
SPC160-6	160	169,6	6		96	103		161,5	2	20	16.00
SPC180-6	180	189,6	6	82	96	123	75	161,5	4	20	17.63
SPC200-6	200	209,6	6	90	100	143	80	161,5	4	25	22.65
SPC225-6	225	233,6	6	90	100	168	60	161,5	4	25	25.11
SPC250-6	250	259,6	6	102	100	193	50	161,5	4	25	29.10
SPC280-6	280	289,6	6	102	100	223	40	161,5	4	25	32.91
SPC300-6	300	309,6	6	104	100	243	25	161,5	4	25	32.50
SPC315-6	315	324,6	6	112	100	258	28	161,5	4	25	37.00
SPC335-6	335	344,6	6	114	100	283	30	161,5	6	25	38.50
SPC355-6	355	364,6	6	114	100	298	30	161,5	6	25	39.50
SPC400-6	400	409,6	6	120	100	343	30	161,5	6	25	46.00
SPC450-6	450	459,6	6	120	100	393	32	161,5	6	25	51.00
SPC500-6	500	509,6	6	126	100	443	32	161,5	6	25	59.00
SPC560-6	560	569,6	6	130	100	503	35	161,5	6	25	66.00
SPC600-6	600	609,6	6	130	100	543	35	161,5	6	25	70.00
SPC630-6	630	639,6	6	130	100	573	35	161,5	6	25	75.00

AUTHORIZED DISTRIBUTOR :



MOTION POWER AND SERVICES CO., LTD (RAYONG BRANCH)

TEL +66 38016999

🌐 www.motion.co.th ✉ sales9@motion.co.th
sales10@motion.co.th



MOTION POWER CO.,LTD (KORAT BRANCH)

TEL +66 44756092

🌐 www.motion.co.th ✉ sales3.mpk@motion.co.th
sales5.mpk@motion.co.th



RPM POWER TRANSMISSION CO., LTD

TEL +66 38212272

✉ sales@rpmpowertrans.com

