

Application

SCF - ALLCO® Sealing Compound

- For seal forming between and around each electrical conductor inside of sealing fitting to restrict the passage of gases, vapors and flames.

SCF - ALLCO® Sealing Fiber

- Forms a positive dam to hold sealing compound in the sealing fitting.

Feature

- SCF - ALLCO® Sealing Compound is water soluble powder that can be easily mixed and poured. Mix 2 parts by volume of SCF -ALLCO® Sealing Compound with 1 part of clean water in a completely clean container. Stir it immediately and thoroughly then pour this compound into the sealing fitting. Compound will harden in 60 minutes then form a secure non-shrinking, acids, water and oil resistant seal.
- SCF - ALLCO® Sealing Fiber is a rope type asbestos fiber that easy to form a dam and non-flammable.

Packing

- SCF - ALLCO® Sealing Compound and Sealing Fiber are packed together in standard package 454 g. (1 lb.).
- Note :** SCF - ALLCO® Sealing Compound and Fiber are approved for use only with ALLOY sealing fittings.

Technical Data

Hazardous Area	Gas	Dust
Zones	1 & 2	21 & 22
Conformity to Standards	EN 60079-0:2012+A11:2013, EN 60079-1:2014, EN 60079-14:2013	
Ambeint Temperature	-20°C to +75°C	

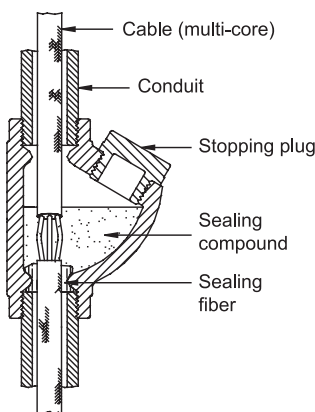

Vertical seal

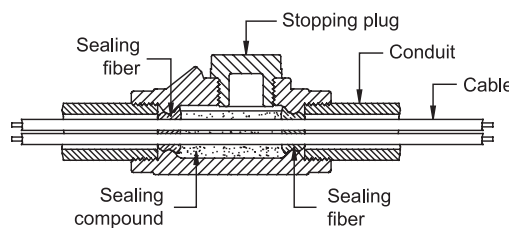

Horizontal seal

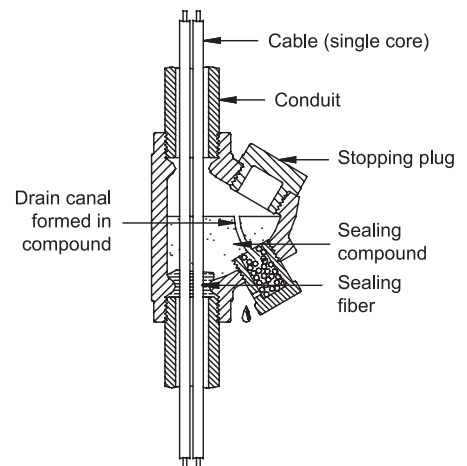

Vertical seal and water drain

Depth of sealing compound should be equal to the trade size of conduit, having a minimum of 5/8 inch thickness. Close the plug immediately after pouring.

Caution : Do not mix more than it can be poured within 10 minutes after adding water. Use cold water, warm water increases speed of setting. Partical of previous mixing or dirt may spoil the seal.