



**DIVISEUSES HYDRAULIQUES SEMI-AUTOMATIQUE  
SEMI-AUTOMATIC HYDRAULIC DOUGH DIVIDERS**

**DVC20BR**

Photos non contractuelles / Photos not contractual



- 20 divisions - Cuve rectangulaire
- Capacité de cuve 16 kg
- Poids des pâtons : de 200 à 800 gr
- Vérin hydraulique
- Couteaux inox
- Montée automatique des couteaux
- 4 roulettes mobiles dont 2 avec freins
- 230/50Hz/3
- Puissance : 1.5 kW
- Poids net : 193 kg

Options :

- Inox - Bac de fleurage - 60Hz - 400V
- Anti projection de farine
- Grilles de subdivisions



- 20 divisions - Rectangular vat
- Vat capacity 16 kg
- Dough piece weight : from 200 up to 800 gr
- Hydraulic jack
- Stainless steel knives
- Automatic knives lifting
- 4 castors (2 with brakes)
- 230-400/50Hz/3
- Power : 1.5 kW
- Net weight : 193 kg

Options :

- Stainless steel frame - Flowering box - 60Hz
- 400V - Anti flour projection
- Subdivision grids

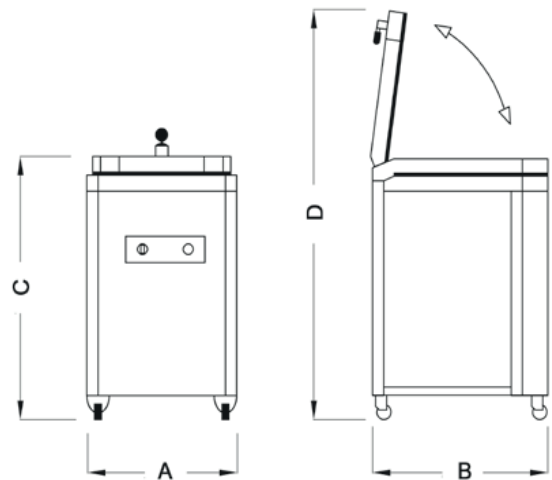

A = 560 mm  
B = 735 mm  
C = 1085 mm  
D = 1600 mm



[www.caplainmachines.com](http://www.caplainmachines.com)

70



Caplain Machines



Caplain Machines



8 / 10 Rue Clément Ader  
77170 Brie Comte Robert  
France



+ 33 1 60 02 19 19