

# CTR | EXCELLENT PERFORMANCE.

The compact rack conveyor dishwasher



A machine for perfect cleanliness and hygiene. Perfectly coordinated accessories. Specially developed chemicals. Advice and personal support. Planning expertise and training courses. Monitoring, reporting and service. All that and more from Winterhalter.



## EVERYTHING IS POSSIBLE.

It has to be compact. Because there's generally not a lot of space in the kitchen. It has to be fast. Because there's a lot to wash at peak times. It has to be modular. So that it can be tailored precisely to meet individual requirements and demands. Naturally it should also be economical to operate. The impossible becomes reality with the CTR from Winterhalter: high washing performance and compact dimensions. Up to 195 racks per hour. Lower consumption values and lower operating costs. Maximum hygiene safety – and a huge degree of flexibility. This is thanks to the modular system, which enables the CTR to be easily planned, individually configured and retrofitted. The perfect solution for up to 400 diners per hour.

### HIGH DEGREE OF FLEXIBILITY

It offers a wide range of machine variants, is available with up to three tanks and has modules and features that can be retrofitted: The CTR is based on a modular system and can be customised to precisely meet your individual requirements. Even for confined spaces.

### CERTIFIED HYGIENE SAFETY

The CTR is designed with hygiene in mind. Doors that open 180°, deep-drawn tanks and a hygienic tank heater. An integrated hygiene mode as standard: If the tank or boiler temperature falls below the set value, the machine automatically reduces the transport speed, thus guaranteeing a hygienic wash. In accordance with hygiene standard DIN SPEC 10534. The CTR ensures you are always on the safe side.

### PERFECT WASH RESULTS

An efficient warewashing system. A new concept with a simplified design and effective hygiene safety and filtration solutions: the CTR also guarantees first-class wash results for large loads.

### ECONOMICAL AND EFFICIENT

Despite its huge rack capacity, it has been possible to reduce rinse water consumption by up to 50 % – to a minimum of just 130 litres per hour. Made possible by the speed-dependent control of the rinse water volume. So you can wash as economically and environmentally friendly as possible.



### RACK CAPACITY

The CTR delivers an impressive rack capacity but with compact dimensions: With a transport speed of up to 195 racks per hour, it can handle a high volume of dishes during peak times. This allows you to simply and effortlessly set the machine performance according to your specific requirements at any given time: By selecting one of the three speed levels: fast, standard and intensive. The stored settings can be adjusted by the service technician according to individual requirements.

### WAREWASHING SYSTEM

The CTR high-performance washing system comprises of five wash arms at the top and four wash arms at the bottom. Thanks to their shape and nozzle geometry, they ensure that water is distributed over the entire wash area. The system has been balanced so that it provides the optimum pressure distribution between the top and bottom elements of the system. This means that dishes are held securely in position to ensure maximum washing performance.

### HYGIENE CONCEPT

The CTR delivers a perfect hygiene concept. The hygiene mode is one innovative feature: If the tank or boiler temperature falls below the set value, the machine automatically reduces its transport speed and thus ensures a hygienic wash. The user can also change to the »Speed mode« at any time. The CTR will maintain its constant transport speed and wash with the selected rack capacity.

If a tank heater overheats due to caked-on dirt, the machine has a safety feature which will switch off the machine immediately and a message is displayed on the screen. After cooling, the thermal fuse resets itself and the machine automatically switches on again.

Other hygiene features: the hygiene design of the interior of the machine and heat recovery with an integrated and easily cleaned grease filter. The hygiene logbook provides additional hygiene safety: It stores all important operating data and the current operational status including fault messages and can also be called up via CONNECTED WASH. The hygiene certificate in accordance with DIN SPEC 10534 confirms the high hygiene standards of the CTR.

### MODULAR SYSTEM

The CTR is available with up to three tanks, with additional pre-wash and drying zones, and optional heat recovery. This results in a large number of different machine variants and the possibility of a customised solution: precisely configured to your individual requirements. Should they change in the future – no problem: the modular design means that modules and features can be retrofitted at any time. You can find an overview on the following pages.

### OPERATING CONCEPT

The CTR makes washing remarkably simple: It is convenient to operate and easy to clean. A smart touch display, with single-button operation, is at the heart of the CTR cockpit. With a language-neutral operator interface and self-explanatory pictograms. Different programmes can be selected for the tank draining process: Each uses the standard drain pump, which protects the user from contact with the wash water and ensures greater safety at work. All wash arms and curtains can be taken out separately and quickly and easily cleaned if necessary. A coding system means they can't get mixed up.

### FILLING AND EMPTYING

The CTR has several programmes for filling and emptying the wash tanks. Quick start: The machine fills in approximately eight minutes (depending on on-site conditions) and is ready for use shortly thereafter. Individual water change: Depending on how soiled the water is and the time available, a part or full regeneration of the tank water can be performed by means of the tank water exchange programme. Quick drainage: In addition to the regular drainage programme, there is also a programme that will pump out all the tank water in just five minutes.

### PRE-WASH ZONE S

The pre-wash zone S is a space-saving addition to the main wash zone and increases the rack capacity of the CTR. It comes without a separate tank and its own wash pump and is 500 mm wide. Wash arms at the top and bottom remove coarse food residues prior to the main wash phase. Its inbuilt filter cassette traps coarse soiling and can be easily removed and cleaned. The pre-wash zone S can be retrofitted.

### PUMPED RINSE

The CTR L is equipped as standard with an additional pumped rinse that reliably removes dirt particles from the wash items before rinsing with fresh water – and filters them out of the water using a finely perforated strainer and a second Mediamat. The result: continuously clean tank water. Depending on the items being washed, the pumped rinse can also be deactivated at any time – for example, when washing large trays.

### DRYING ZONES

The optional and retrofittable drying zones allow cleaned wash items to be quickly reused. This is especially recommended for wash items that are particularly hard to dry. For maximum flexibility in room planning, the CTR drying zone is not only available in a straight version, but also in a corner version. Ideal for small kitchens and confined spaces.

### HEAT RECOVERY \*1

Intelligent use of energy: the CTR is optionally available with an Energy heat recovery system. The energy in the hot steam is used to preheat cold inlet water through the machine air circulation. This improves the kitchen climate, protects the environment, reduces energy consumption and lowers operating costs. The need to connect the warewasher directly to the on-site exhaust air system is no longer needed with the CTR – even without integrated heat recovery.

### EFFICIENT FILTRATION

The cleaner the wash water, the fewer changes of water are required – and the better the wash result. That's why the CTR is equipped with Winterhalter's proven and efficient quadruple filtration system. In Steps 1 and 2, coarse soiling is first collected by removable strainers in the main wash zone. In Step 3, the Mediamat then filters the finest particles, such as coffee grounds, from the wash water. And in Step 4, the pump inlet filter protects the wash pump from mechanical damage. If the CTR is fitted with a pre-wash zone, food residues are trapped in a separate and easy-to-clean filter system before the main wash zone.

### PRE-WASH ZONE M

For a better wash result and a significant increase in the rack capacity, the pre-wash zone M has its own deep-drawn tank, a double warewashing system at the top and bottom and its own pump. It has a width of 800 mm. The two-part filter system catches food residues and prevents them entering the main wash zone. A further advantage: by using the energy from the main wash zone, it pre-heats the dishes with no additional costs – and thus stabilises the temperature level across the entire washing process. Its own hygiene door ensures easy operation and ergonomic cleaning. The pre-wash zone M can be retrofitted.

### RACK-ACTIVATED ZONE ACTIVATION

An economical feature of the CTR: The zones for the pre-wash, main wash and rinse are activated by the machine control unit only if they are actually required – that is, the zones activate only when a rack enters the respective zone. Partial utilisation of the machine conserves resources and lowers operating costs. Because water, power, detergent and rinse aid are used as efficiently and economically as possible.

### SPEED-DEPENDENT RINSE WATER VOLUME

For a significant reduction in water consumption and operating costs, the CTR adapts the rinse water volume automatically to the current transport speed. Based on need – from an economical 130 litres per hour up to a maximum of 260 litres per hour. Furthermore, an individual setting allows you to determine whether the washing operation is designed for the highest possible energy savings or a high rack capacity.

### CONNECTED WASH \*2

Greater safety, greater efficiency: The CTR can be networked with a computer or mobile device via CONNECTED WASH. This creates the basis for the analysis and evaluation of all the important operating data. To optimise the entire washing process.



A detailed overview of the CTR is available on our website at:

>> [www.winterhalter.com/ctr](http://www.winterhalter.com/ctr)

\*1 Room ventilation is to be provided by the customer according to local guidelines, e.g. DIN EN 16282 / VDI 2052. Sensitive and latent thermal radiation from the machine must always be taken into account.

\*2 You can find out in which countries CONNECTED WASH is currently available and what functions and options it offers at [www.connected-wash.com](http://www.connected-wash.com)

# CTR MODULES

What needs to be done to develop a conveyor dishwasher that offers more possibilities? This question resulted in the creation of the CTR. Our engineers abandoned the conventional path of the static machine model and designed the CTR to be a flexible system: with a compact and powerful machine model at its heart. With various modules for attachment, the machine can be perfectly customised to meet the customers' requirements. The CTR's area of application is therefore exceptionally broad and ranges from restaurants through to canteens and even motorway services. The result is always the same: a tailor-made rack conveyor dishwasher.

## MAIN WASH ZONE

CTR M single rinse  
Length of zone: 1,400 mm.  
CTR L dual rinse  
Length of zone: 1,600 mm.

## PRE-WASH ZONE S

Length of zone: 500 mm.  
Extends the main wash zone.  
Increases rack capacity as a priority.  
Retrofittable.

## PRE-WASH ZONE M

Length of zone: 800 mm.  
Prevents soiling entering the main wash zone.  
Increases rack capacity.  
Improves the wash result and reduces energy demand.  
Retrofittable.

## STRAIGHT DRYING ZONE

Length of zone: 700 mm.  
A drying zone in a linear configuration.  
To make sure cleaned wash items are ready quickly for reuse.  
Retrofittable.

## CORNER DRYING ZONE

Length of zone: 795 mm.  
Corner drying zone (90° or 180° angle).  
For small kitchens and confined spaces.  
Retrofittable.

## HEAT RECOVERY

Energy heat recovery utilises energy contained in the generated steam for optimum energy utilisation.  
Improves the room climate and lowers operating costs.  
Retrofittable.

### SINGLE RINSE



### DUAL RINSE



↔ = Retrofittable

# PROFESSIONALLY PLANNED. NEATLY SOLVED.

Washing up plays a key role in foodservice but is rarely in the limelight. Only when everything is running smoothly in the wash up area can the overall kitchen function effectively. This means it is even more important to professionally plan the washing process and warewashing solutions with skilled partners.

## ERGONOMICS

Pre-sorting dirty dishes can often be a bottleneck. The solution: A professionally planned and ergonomically designed work space with minimal handling. For smooth and fast work.

## ROOM CLIMATE

Pleasant room temperatures and reduced humidity: modules such as the Energy heat recovery create a well-balanced room climate. The option of retrofitting makes the planning process even more flexible.

## COMPACT

Compact dimensions and a multi-module concept, simplify kitchen planning. And enable tailor-made solutions even for complex room conditions.



## HYGIENE

The separation of clean from dirtier areas is often a challenge. Flexible machine systems like the CTR enable the most diverse planning and installation options and ensure the required hygiene.

## EFFICIENCY

One of the most important subjects when it comes to a kitchen: efficiency and economy. It's great if a machine with an intelligent concept can ensure operating costs are reduced to a minimum.

## USER FRIENDLINESS

Good kitchen planning can become outstanding when employees enjoy working with a warewasher. Doors that rotate 180°, for example, make it easy and ergonomic to access the interior.

## WORKFLOW

Ensure an efficient washing process with the CTR: from the return of dirty wash items to restocking with clean dishes. Perfectly coordinated work processes make employees and guests happy.



# A WIN-WIN-WIN SITUATION.

The perfect kitchen: with tailor-made washing technology and an efficient washing process. This is the goal of professional kitchen planning. That's why we do everything possible to support our customers and partners during the planning phase. With our expertise as worldwide washing specialists. With expert advice on technology, potential savings options and the digital possibilities of process optimisation. With modern and high-quality dishwashing technology such as the CTR: the compact and powerful rack conveyor dishwasher that can be tailor-made to precisely meet individual customer requirements. And of course with everything to make the work of experts in specialist planning easier: from BIM to 3D tools. This gets the project off to a great start under the best conditions. And makes everyone happy: the customers, the specialist planners and all of us at Winterhalter.

*»200 employees eat in our company canteen every day. However, our kitchen is very small. That's why it was a real challenge to find the right dishwasher. CTR gives us exactly that. Thanks to its modularity, it fits perfectly into our kitchen and can handle even large amounts of dishes in a short period of time.«*

Falko Geis, COMPANY TECHNICIAN, AVIRA | TETTANG



Note: the product illustrations are customer-specific configurations that may also include products from other manufacturers.



*Cleanliness and hygiene. Every single one of our products plays its part. Together they create the perfect wash result. Welcome to the complete Winterhalter system!*

## WASH RACKS

Custom-made for glasses, trays, dishes or cutlery. With their functional design they adapt precisely to the respective wash items, protecting them and preventing damage. They ensure ideal water and air circulation and fast drying. And of course they make handling and transporting wash items easier.

Wash racks have a decisive influence on the quality of the wash result and the total operating costs. We advise which racks best suit your requirements. Culminating in the best solution for you.



## CHEMICALS

Washing is essentially about two things: perfect cleanliness and maximum hygiene. Chemicals have a decisive influence on both. This is the reason they are an important component of the overall Winterhalter system.

Many years ago at our German headquarters, we therefore established a research and development department with an in-house laboratory. Here we develop and test formulae for a premium range of detergents and hygiene products. These are precisely tailored to the different wash items and types of contaminants, economical to use, and they can be ideally combined with other products in our range. They work together perfectly and deliver first-class wash results.



## WATER TREATMENT

Deposits. Streaks. Marks. They are »unwanted gifts from the kitchen« and the natural enemies of any restaurateur. They are the hallmark of a poor wash result. Limescale impairs the effect of detergent and rinse aid and damages the machine in the long-term. The problem is water quality – the solution is professional water treatment.

Winterhalter has developed the DuoMatik 3 softener especially for high-performance machines such as the CTR. The external device does not require a power supply and works mechanically to ensure consistently good water – without any regeneration break, thanks to a pair of alternating ion exchange cartridges. If you demand even higher water quality: The compact RoMatik 420 reverse osmosis device achieves almost 100% demineralisation, even where large volumes of water are required. The result is gleaming wash results, with no need for subsequent polishing.



## ACCESSORIES AND SPACE PLANNING

**The product: first class.** Washing technology from Winterhalter stands for the highest standards of wash results. However, as the worldwide washing specialists, our demands are higher: Our objective is not just to offer our customers first-class wash results. Our desire is to design their washing process as efficiently as possible. The original Winterhalter accessories create the basis for this.

**The tailor-made solution:** Washing technology is only perfect when it is precisely tailored to meet individual requirements: the space and the employee environment, the capacities and the special requirements and demands. Winterhalter has developed a diverse range of handling systems: Inlet or outlet tables, in linear or corner configurations. Mechanical and electrical corner conveyors, at an angle of 90° or 180°. Clearing and sorting stations, drying zones, roller tables and rack shelves. This provides a wide range of installation and combination options: for flexible space planning. And the optimal washing process for you.

What can we do for you? Let's talk about it: Tel. +49 7542 402-5408 or [www.winterhalter.com/contact](http://www.winterhalter.com/contact)

## »We are family people!«

Down-to-earth. Forward-looking. With a focus on family. The culture and values of our family have shaped the Winterhalter company for three generations. Close to staff, customers and partners. Long-term thinking with a view to the generations to come. Taking personal responsibility – all typically Winterhalter. We are proud of our family company. And we are pleased to grow a little more every day.



Karl Winterhalter



Jürgen Winterhalter



Ralph Winterhalter

### THE FIRST WINTERHALTER



It all began in 1947: Karl Winterhalter established his own company in Friedrichshafen. He started by salvaging scrap metal from the war, which he used to manufacture household goods. Cooking pots and ovens, for example. A short time later he specialised, and in 1957 launched the GS 60 model: the first commercial warewasher from Winterhalter. That was the starting signal. Since then the company has always pursued a single goal: perfect wash results as part of an efficient washing process. With this holistic approach, Winterhalter has developed from a machine supplier to the full system provider of warewashing solutions it is today.

*»Products, advice, service – three factors that intertwine seamlessly at Winterhalter. And that makes our customers feel safe in the knowledge that they have the right partner for any issue relating to the washing process.«*

### FROM WAREWASHER TO WAREWASHING SOLUTION

In days gone by, all we needed to do was deliver the new warewasher to our customer's kitchen on a hand truck. Now it's about the development of a new, individual warewashing solution, which is perfectly coordinated with the on-site situation and the special requirements and preferences of the customer. A solution of this type is based on clear analysis and planning. To achieve this, we visualise the room layout using state-of-the-art CAD software in 2D and 3D. For a bespoke and efficient washing process.



OVER **2.000**

EMPLOYEES WORLDWIDE

High quality standards. Diligence. Curiosity and ambition. These are the typical attributes of a Winterhalter employee. And with them, we have grown from a small Swabian family company into a global player: with over 40 branches worldwide and distribution partners in over 70 countries. We are proud of what we have achieved. And we are proud of each and every employee who has done their bit. So we would just like to take this opportunity to officially say »Thank you!«



### OUR ACADEMY OF WASHING SCIENCE

Almost 1,000 participants per year and 250 training days worldwide: as part of our training programmes we pass on our knowledge and experience in the discipline of »warewashing«. We provide training to our own personnel as well as to our retail and service partners. Our objective: every Winterhalter customer should receive informed advice and professional support in the specific situation. Whether it's an initial informative discussion, installing a warewasher, or service and maintenance appointments.

### IN-HOUSE LABORATORY FOR IMPROVED CHEMICALS

As a specialist in warewashing, do we want to rely on the products of other manufacturers? The answer to this question was an immediate and resounding »No!«. This was the moment, when our in-house research and development laboratory was born: we have been developing our own formulas for original Winterhalter chemicals for many years now, from detergents and rinse aids to hygiene products.

### Good to know

As a specialist in warewashing, at Winterhalter we set high standards for ourselves: we don't just want to meet our customers' current requirements. We want to support them proactively and gain their trust for the long term. Service plays an important role here: our comprehensive network guarantees fast and professional support on site. Worldwide.

We and our service partners are there when you need us. On that you can always rely with Winterhalter.



What opportunities does new technology offer? How is our society and the world of work changing? Which trends and developments will shape commercial warewashing in the future? We find all of these questions extremely exciting. And that's why we are already working on developments that will affect us and our customers tomorrow, and the day after that. You can take a look at the solutions that we have developed in our NEXT LEVEL SOLUTIONS. Current examples include CONNECTED WASH and PAY PER WASH.

>> [www.connected-wash.com](http://www.connected-wash.com) >> [www.pay-per-wash.com](http://www.pay-per-wash.com)

### »See you again soon!«

Customers often own a Winterhalter warewasher for 15 or 20 years. So our customers only have to worry about disposing of their old equipment once every few decades. What's more, we take care of this ourselves. We design our machines as modular systems, so they are easy to dismantle if ever the need arises. We reduce the range of materials, use standardised construction materials and label plastic parts for easy recycling. Winterhalter warewashers have a particularly high recycling ratio thanks to these and many other measures.



### MADE IN GERMANY AND SWITZERLAND

As ever, it is not simply an indication of origin, but a seal of quality: products made in Germany and Switzerland are recognised worldwide for their premium quality and reliability. For engineering, inventiveness and precision. Winterhalter is the best proof of this: in Meckenbeuren, Edingen and Rüthi, we develop and produce solutions for first-class cleanliness and hygiene. This is our promise for every single warewasher that leaves our factory.

## CONFIGURATION EXAMPLES

Ideal for any room: The CTR's various setup and combination options offer the best solution for every kitchen.

### CTR M

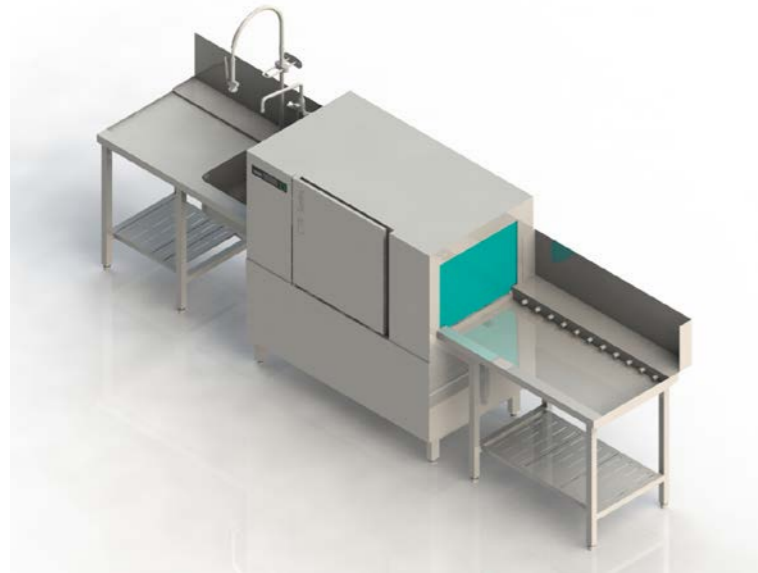

#### Hotel, restaurant, canteen meals for 100 to 200 diners

- Performance: up to 120 racks per hour
- Total length/depth: 3,800 mm / 815 mm
- Loading area: Inlet table with sink and pre-spray unit, space for two racks
- Unloading area: outlet roller table, space for two racks

### CTR SL WITH ENERGY

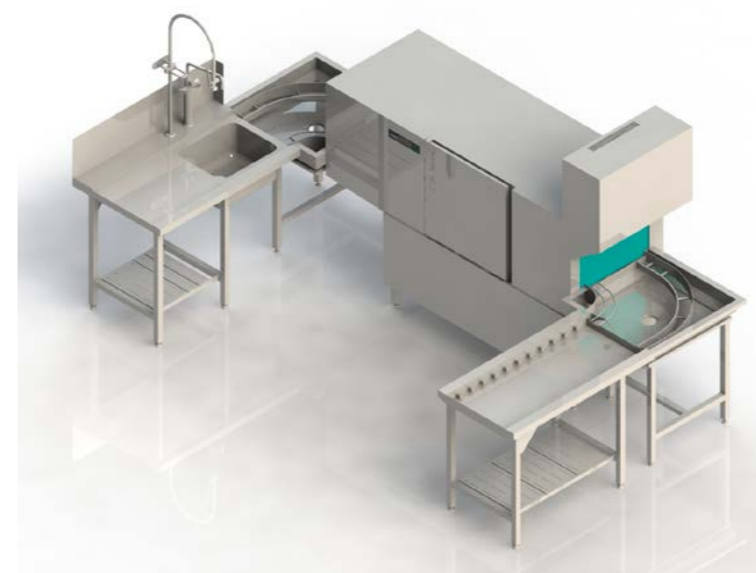

#### Hotel, restaurant, canteen meals for 150 to 300 diners

- Performance: up to 160 racks per hour
- Total length/depth: 3,800 mm / 2,100 mm
- Loading area: Inlet table with sink and pre-spray unit, space for two racks, mechanical 90° inlet corner conveyor
- Unloading area: mechanical 90° outlet corner conveyor, outlet roller table, space for two racks

### CTR M-M WITH ENERGY

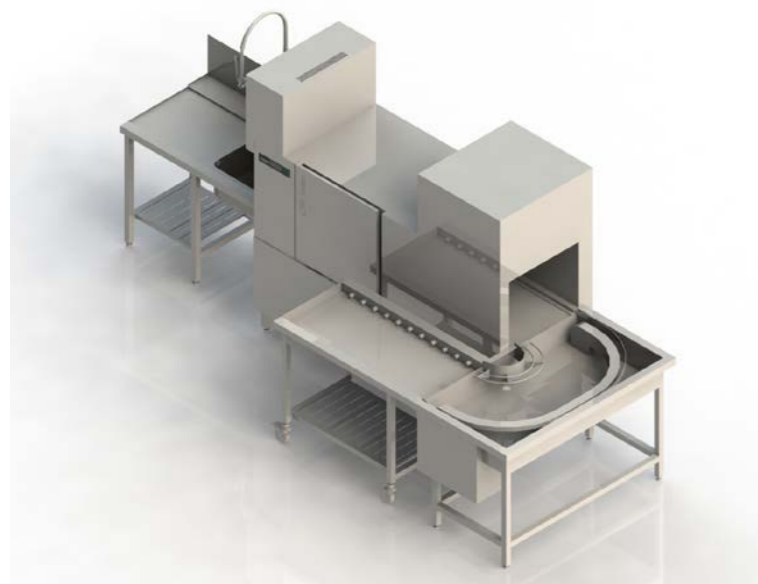

#### Hotel, restaurant, canteen meals for 100 to 200 diners

- Performance: up to 120 racks per hour
- Total length/depth: 4,100 mm / 1,550 mm
- Loading area: Inlet table with sink and pre-spray unit, space for two racks
- Unloading area: electrical 180° outlet corner conveyor, rotating outlet roller table, space for two racks

### CTR ML-M WITH ENERGY

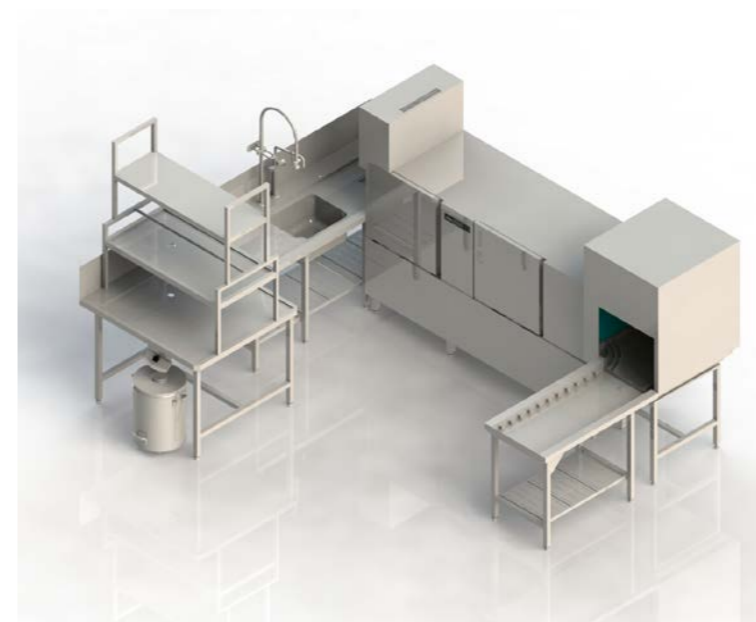

#### Hotel, restaurant, canteen meals for 200 to 400 diners

- Performance: up to 195 racks per hour
- Total length/depth: 4,000 mm / 3,150 mm
- Loading area: clearing and sorting station, inlet table with sink and pre-spray unit, space for two racks, 90° corner inlet
- Unloading area: mechanical 90° outlet corner conveyor under corner drying zone, outlet roller table, space for two racks

# CTR TECHNICAL DATA

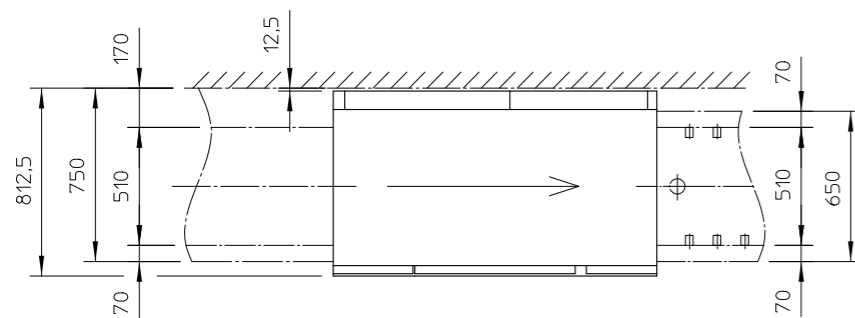
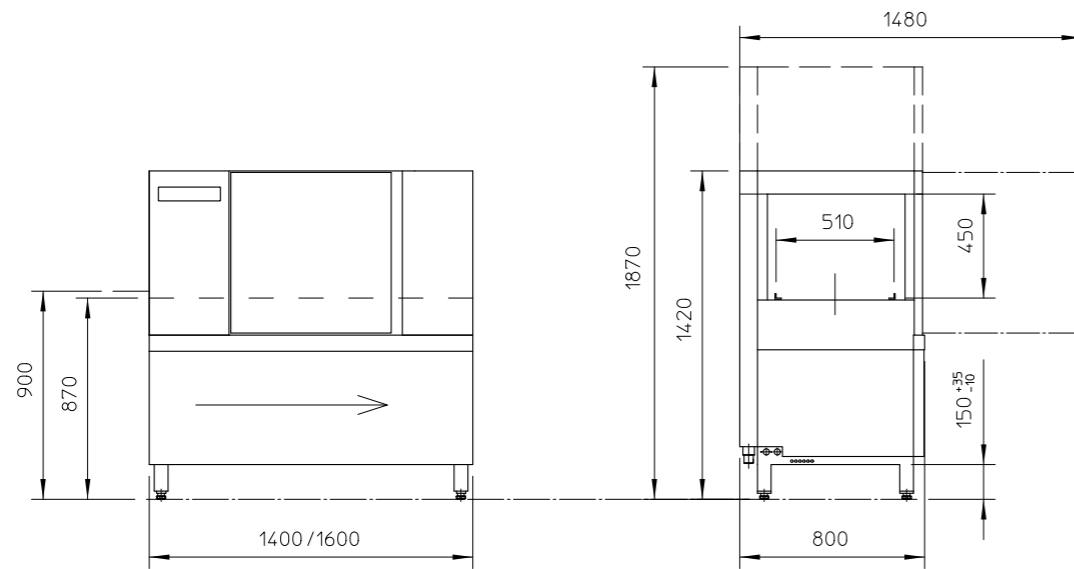
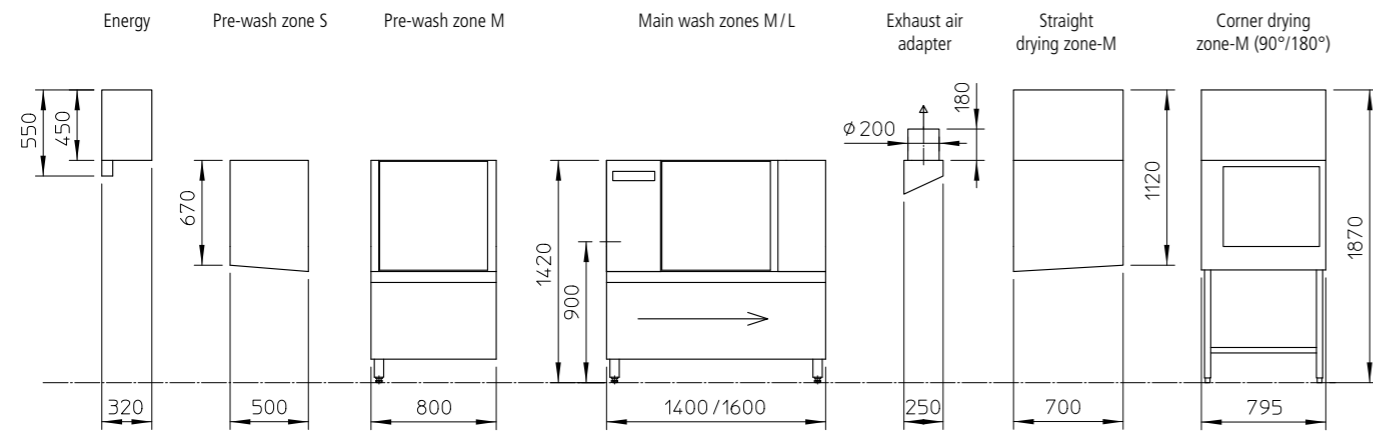

## General data

		CTR M Single rinse	CTR L Dual rinse
Tank capacity	l	75	83
Rack dimensions	mm	500x500 (for straight installation: 500x600)	
Clear entry height	mm	450	
Clearance width / passage width	mm	530/510	
Working height	mm	900	
Wash pump	kW	2.2	
Noise emission	dB(A)	< 70	
IP protection class		IPX5	
Max. inlet water temperature	°C	60 (Energy: 20)	
Required water flow pressure on-site	bar/kPa	1,5–10,0/150–1.000	
Tank temperature	°C	63	
Boiler temperature	°C	85	

## Weight net / gross

Straight drying zone	kg	76/121
Corner drying zone	kg	103/148
Energy	kg	41/44

## Specific data

		CTR M	CTR SM	CTR MM	CTR L	CTR SL	CTR ML
Theoretical capacity *1	Racks/h	50/75/120	70/100/150	90/125/185	60/85/130	80/110/160	100/135/195
Maximum DIN capacity	Racks/h	100	140	125	116	156	135
Average rinse water volume *2	l/h	114	152	190	130	168	205
Average energy consumption *3	kW	18.0	21.9	24.0	19.8	23.7	25.6
Weight net / gross	kg	240/293	271/338	346/421	264/317	295/362	370/445

\*1 Factory setting. Hygienic wash results at all speeds according to DIN SPEC 10534.

\*2 Non-binding information. The actual rinse water volume may vary depending on the on-site conditions.

\*3 Average data incl. drying zone with exemplary conditions, operating mode and cover rate. Individual, deviating values possible.

## OPTIONAL ADDITIONS

- Heat recovery Energy \*4
- Working direction can be selected: left–right / right–left
- working height: 850 mm, 950 mm \*4
- base installation
- pre-wash zone S \*4
- pre-wash zone M \*4
- straight drying zone \*4
- corner drying zone \*4
- exhaust air adapter (only outlet end) \*4
- emergency stop switch \*4
- dual rinse
- increased boiler heating at the cold water connection \*4

\*4 Retrofittable

*»In this brochure, we have presented our CTR:  
its product features, application options and what  
sets it apart. However we were not able to provide  
you with the strongest argument of all here: the  
positive experiences of our satisfied customers.  
Just ask next time you see a CTR anywhere.  
There is no better aid to making your decision.«*

*Jürgen and Ralph Winterhalter*

