



WAREWASHING  
RACK-TYPE DISHWASHER

# PROFI CN

EFFICIENT - RELIABLE - INNOVATIVE



 made in germany

## MADE IN GERMANY

„Made in Germany“ has been synonymous with quality and reliability in the premium segment for a long time and still is today. A company can only maintain its hold on the market by keeping its promise to continually deliver high quality.

## WORLDWIDE

Whether you need a completely new kitchen or a replacement item our competent subsidiaries and partners all over the world would be pleased to support you. It's nice to know we are always there.



1883 Mr. Charles Clarence Hobart builds his first engines and generators in Middletown, Ohio.

1886 J.C. Cochran receives the patent for the first dishwasher.

1897 The HOBART ELECTRICAL MANUFACTURING COMPANY was founded in Troy Ohio, through the acquisition of the engine and generator factory of the HOBART family.

1903 HOBART builds the first food processor (a self-contained powered coffee mill).

1926 HOBART purchases The Crescent Washing Machine Company, and enters the commercial warewashing market: the first warewashing machine carrying a HOBART label.

1930 Foundation of the HOBART MASCHINEN GESELLSCHAFT in Hamburg, Germany.

1953 HOBART receives the patent for the first flight-type dishwasher.

1960 Acquisition of the dishwashing department of the company K. Martin, Offenburg, Germany.

1980 Production plant in Elgersweier, Germany, was newly built.

1986 PREMARK INTERNATIONAL GROUP was formed in Deerfield, Illinois.

1997 HOBART CORPORATION'S 100th anniversary.

1999 Integration of PREMARK into ITW.

2004 HOBART relocates to Elgersweier

2006 Launch of HOBART's export activities

2007 HOBART's PREMAX line begins a new chapter in the annals of dishwashing technology. The PREMAX FTP flight-type dishwasher cuts water use by up to 50%, energy use by up to 30%, and use of chemicals by up to 80%.

2009 HOBART introduces the SENSOTRONIC, the world's first intelligent dishwashing technology

2010 Tenth record year in succession for HOBART



## HOBART PHILOSOPHY

### UNDERSTAND – SIMPLIFY – FOCUS – INNOVATE

This philosophy provides the continuing motivation to develop innovations, which are the best driver of economic development and a guarantee for job security. It is a philosophy of the essential, of customer value, of simplicity. A philosophy built on the conviction that things created for a purpose and with logic, do not need to be completely renewed, but must instead be subject to continuous evolution.

## HOBART VISION

### “WASH WITHOUT WATER“

Before PREMAX, a flight-type dishwasher with a 50% water saving would have been utopia. At HOBART, efficiency and responsible use of natural resources when developing new machines have always gone hand in hand. With PREMAX, the company has set a further milestone, and has further extended its leadership in innovation. But even so, HOBART is not satisfied with this. The company will not diminish the pace of its innovation, and will look for further opportunities to save even more. When the day arrives that a machine is able to wash without water, we already know, it will be a PREMAX.

## HOBART FOCUS

### INNOVATION

Without the readiness to invest in the future, without the natural reaction of always questioning ourselves, without interdisciplinary basic research and consistent customer focus, PREMAX would be inconceivable. Worldwide, over 300 research and development engineers and global marketing teams, who identify customer requirements, as well as the company's own Tech-Center, with over 1,000 patent applications annually, develop innovative technology and make PREMAX possible.

### ECOLOGY

The HOBART environmental protection program CO<sub>2</sub>NSEQUENT has been in existence for some time. The program includes a large number of measures that are all related to protecting the environment. These measures are implemented in production, purchasing, the development and sale of products and in additional projects.

### ECONOMY

Already in the early 1980s our E-formula set standards in energy saving and recovery which are still unique today. This innovative spirit found its fulfillment in the PREMAX line. The PREMAX flight-type dishwasher saves up to 50% water, 30% energy, and 80% chemicals in comparison with conventional technologies, making HOBART a model in terms of efficiency and economy.





1

2

3

4

1 "We operate at constant high capacity. One bus after the other stops at our motorway service area for a break. Our warewashing has to cope and cannot afford to break down. With the PROFI CN, we have found the perfect machine for our needs."

2 "The eye leads to the stomach. Therefore we devote great attention to the presentation of our food. Sparkling and hygienically clean tableware are an obvious prerequisite. With the PROFI CN, we can guarantee this at all times."

3 "In addition to keeping operating costs down, we have stringent demands regarding hygiene. The PROFI CN satisfies both. It gives us the security of reduced operating costs, which pleases the management."

4 "Throughout the day, we get a constant flow of wash ware. Therefore a rack-type dishwasher was the right choice for us. Even though we are strapped for space, the PROFI CN fits in perfectly and is a reliable partner around the clock."

Marjan Ružič  
Motorway service area  
Ljubljana, Slovenia

Darja Tamm  
Restaurant  
Tallinn, Estonia

Juan Ogella  
Retirement and nursing home  
Sevilla, Spain

Dimitry Plostak  
Hotel  
Moskva, Russia



# PROFI CN

EFFICIENT – RELIABLE – INNOVATIVE

## 1 | ECONOMY

**PATENT  
PENDING**

### ENERGY-MANAGEMENT EFFICIENT

A conventional rack-type dishwasher loses 40% of the energy available in the machine via the exhaust system. The distribution of water and the air stream have a considerable influence. The new energy-management EFFICIENT reduces the evaporation loss. The improved arrangement of the wide angle nozzles FAN and the orientation of the wash arms reduce the air flow within the machine. The patent pending wide angle nozzle FAN spreads out a 65% wider and more even spray pattern. Therefore the recirculation of water can be reduced for the same wash result. In order to keep the system in balance less air/water steam has to be exhausted. The new energy-management reduces the energy loss of the rack-type dishwasher by up to 15%.

**PATENT**

### DETERGENT SAVING SYSTEM LOW-CHEM

With the optional detergent saving system LOW-CHEM detergent is injected directly into the wash tank, which is continuously regenerated by fresh water from the rinse. Therefore detergent is added to maintain the concentration according to the added regeneration volume. The enhanced LOW-CHEM detergent saving system directs only 105 litres of fresh rinse water into the wash tank for regeneration. Ahead of the final rinse, detergent is flushed off the wash ware by the RADIUS pre-rinse nozzle and diverted back into the wash tank. The dosing of detergent depends on the regeneration water volume. As a result detergent consumption is reduced by up to 70% compared to conventional systems.

## EFFICIENT – OPTIMAL



Up to 65% wider and more even spray pattern.

## ECOLOGICAL – ECONOMICAL

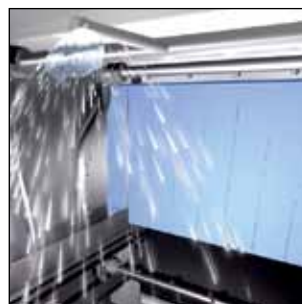

Up to 70% detergent saving.

**HOBART**

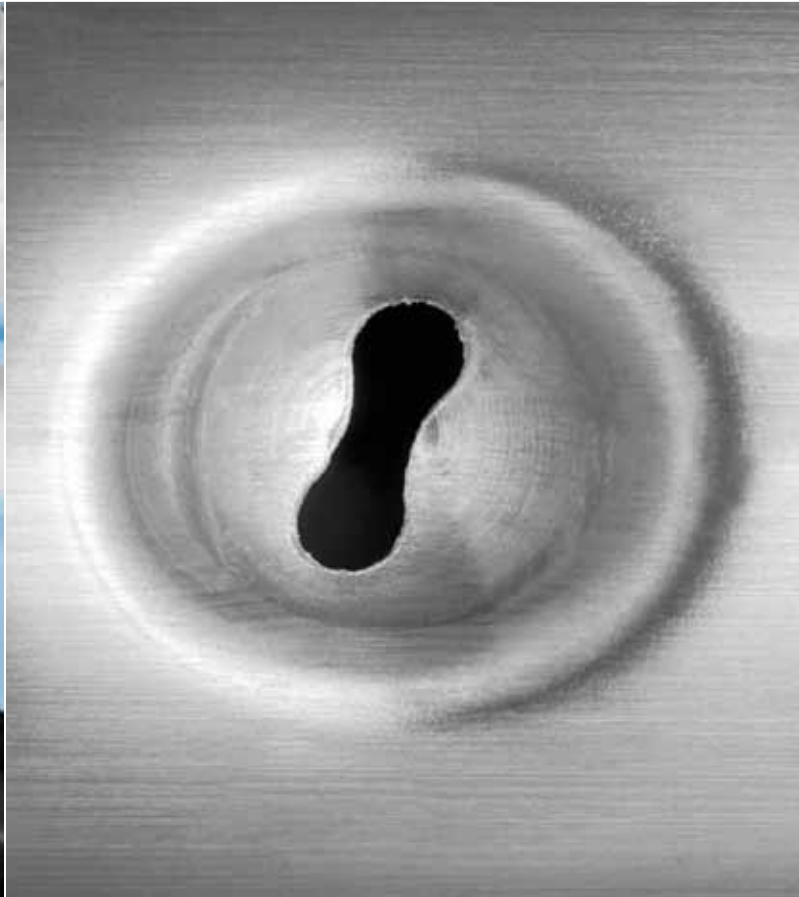



## 1 | ECONOMY

### HOBART HEAT RECOVERY

HOBART's heat recovery system functions according to the countercurrent principle, using the energy from the extracted air to heat up the incoming water. The energy exchange takes place in the HOBART high-performance condenser. At the same time, the extracted air is cooled down and dehumidified. The HOBART heat recovery system reduces energy consumption by up to 8.5 kW and total connected load to 36.7 kW.<sup>1)</sup> The extracted air can be led directly into the building's ventilation ducting.<sup>2)</sup>

### HOBART HEAT PUMP

THE HOBART heat pump uses the residual energy in the extracted air following heat recovery. A compressor and refrigerant are used to ensure efficient heat recovery. The amount of recovered energy is sufficient to heat the wash and rinse water. This innovative technology reduces energy consumption by up to 10 kWh and total connected load to 29.9 kW.<sup>3)</sup> The temperature of the extracted air is reduced to approx. 20 - 24°C.<sup>4)</sup> The extracted air can be blown directly into the room.<sup>2)</sup>

<sup>1)</sup> Calculation example for the PROFI CN S-A-DS, C20 compared to models without heat recovery.

<sup>2)</sup> Conditional on compliance with VDI 2052

<sup>3)</sup> Calculation example for the PROFI CN S-A-DS, CHP compared to models without heat pump.

## 2 | WASH RESULT

### PATENT

### WASH SYSTEM CONTACT-PLUS

The impact with detergent solution via the wash arms is, apart from the temperature, the main factor influencing the cleaning result. The precision of the FAN wide angle nozzles makes it possible to reduce the distances between the wash arms. The wash arms are located very close to one another and thus achieving full cleaning performance. In connection with the 65% wider wash jets the new configuration of the FAN wide angle nozzles washes the items three times per wash arm. The new wash system CONTACT-PLUS with its 6 wash arms above and 5 wash arms below guarantees an optimal wash result.

<sup>4)</sup> Values in continuous operation +/-10 % depending on incoming air in the room and inlet temperature of the fresh water (values based on 10°C incoming water and 23°C ambient air temperature)

## ECONOMICAL – EFFICIENT



The HOBART heat pump uses the residual energy in the extracted air.

## PERFORMANCE – POWERFUL



Highest performance due to 6 wash arms above and 5 wash arms below.

**HOBART**





## 2 | WASH RESULT

### PATENT

#### RINSE TRI

The optional HOBART triple rinse TRI consists of the RADIUS pre-rinse nozzle, a pumped rinse and a fresh water final rinse. The RADIUS pre-rinse nozzle rinses off most detergent from the wash ware before entering the rinse zone. The water is directed back into the wash tank, minimizing detergent addition into the recirculating rinse water.

## 3 | HANDLING

#### HANDLING ASSISTANT EASY

featuring

- SMARTRONIC control
- PROTRONIC control
- Drop-In wash system
- Coded wash and rinse arms
- Coded curtains

#### SMARTRONIC CONTROL

Switch on/off - all other functions are automatically assumed by the control.

#### PROTRONIC CONTROL

The innovative, multi-line text and symbol display is operated by touchscreen. This ensures easy operation and minimises errors.

#### DROP-IN WASH SYSTEM

Easy to take out and insert.

#### CODED WASH AND RINSE ARMS

The wash and rinse arms are clearly designed to prevent risk of confusion when inserting.

#### CODED CURTAINS

Easy to take out and insert. The clear marking on the wash curtains prevents confusion when inserting.

### DIRECT – DYNAMIC



Best wash results due to triple rinse.

### OBVIOUS – SIMPLE



The curtains are marked distinctively.

# HOBART

## 4 | SUPPORT

### CLEANING ASSISTANT SUPPORT

comprising

- Wash system
- Bayonet catch
- Completely moulded washing tanks
- 1-part strainer
- 150 mm floor clearance
- Condenser
- Panorama door

### WASH SYSTEM

The wash systems are easy to remove and to insert due to a drawer mechanism.

### BAYONET WASH ARM CATCH

The wash arms can easily be opened and closed to simplify cleaning.

### MOULDED DRAIN ELEMENT

Dirt is directed via beading to a central point and into the drain. This prevents dirt accumulation in the tank.

### COMPLETELY MOULDED TANK

The tank sump and tank bottom are moulded from one single part. There are no corners and edges or weld seams where dirt could accumulate. This optimizes cleaning and hygiene.

### CONDENSER

Optimal accessibility for water spraying - by simply removing the front covering.

## SIMPLE – CLEAN



Wash arms can easily be opened and closed.



## 5 | TECHNICAL DATA

Racks (number/h)			Conveyor speed (m/min)	Water consumption		Energy consumption (connected load) [kWh; (kW)]		Recommended model selection	Total length  (in mm without drying zone)
Speed 1	Speed 2 (as per DIN 10510)	Speed 3		(l/h)	(l/rack)	with heat recovery	with heat pump		
-	90	120	0.67	230	1.9	28.0 (31.5)	20.0 (21.8)	CNA	1,350
-	100	150	0.83	240	1.6	28.0 (31.8)	19.0 (22.1)	CNE-A	1,850
-	120	180	1.00	260	1.4	32.0 (36.0)	22.0 (26.3)	CN-L-A	2,000
-	120	180	1.00	260	1.4	32.0 (36.0)	22.0 (26.3)	CN-C-A	2,375
-	150	220	1.25	260	1.2	33.5 (36.7)	23.5 (27.0)	CN-S-A	2,250
120	180	250	1.50	260	1.0	33.5 (38.5)	24.0 (28.8)	CNE-SA	2,750
120	180	260	1.50	260	1.27	43.0 (48.7)	33.5 (42.0)	CN-L-AA	2,900
120	190	280	1.58	330	1.2	44.5 (49.4)	35.0 (42.7)	CN-S-AA	3,150
120	210	320	1.75	330	1.03	44.5 (49.4)	35.0 (42.7)	CNE-S-AA	4,050

## 6 | MODULE SELECTION

### PRE-WASH ZONE

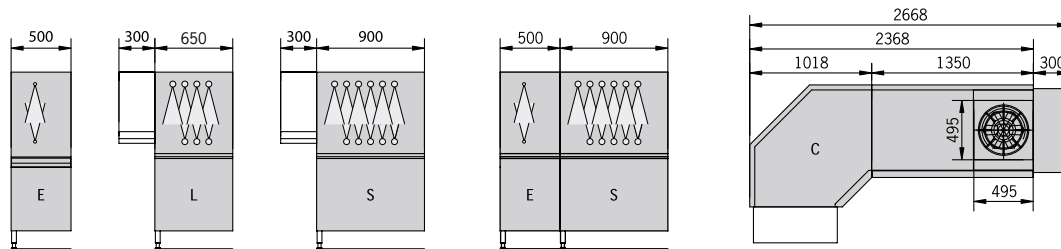

### MAIN WASH ZONE

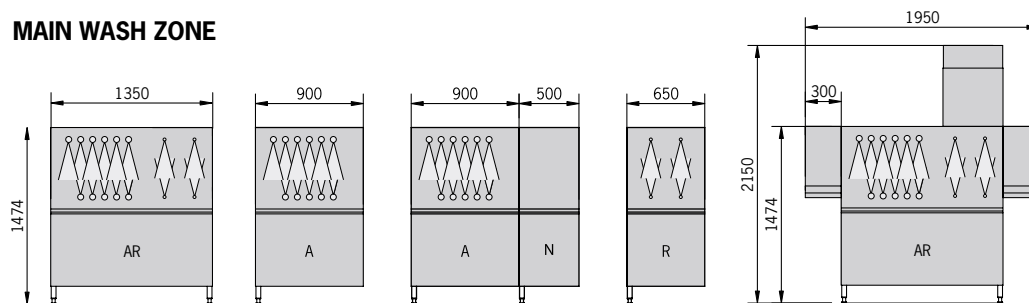

### DRYING ZONE

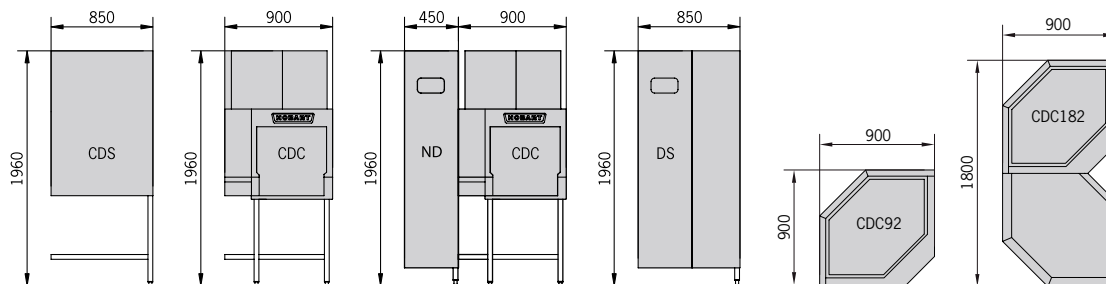

### HEAT RECOVERY/HEAT PUMP

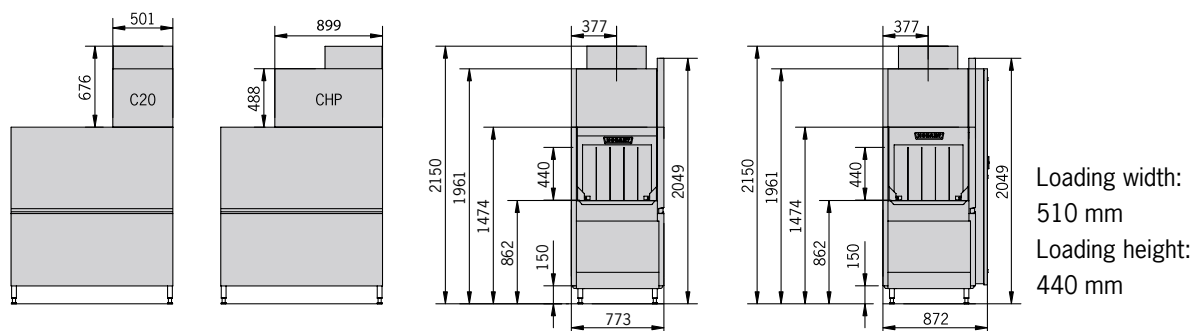



WAREWASHING  
RACK-TYPE DISHWASHER

# PROFI CN

EFFICIENT – RELIABLE – INNOVATIVE

## GOOD – BETTER – PROFI

Under continuous high capacity conditions in hotels, restaurants, nursing homes, canteens and motorway service areas, warewashing equipment must meet the most stringent requirements in terms of quality and reliability.

With its energy management system EFFICIENT and its highly effective heat recovery systems, HOBART sets new economical standards in rack-type dishwashers, while also protecting the environment by reducing consumption levels.

With its perfectly hygienic wash result and practical use features, the PROFI CN stands for quality – made by HOBART.



WAREWASHING

COOKING

FOOD PREPARATION

WASTE TREATMENT

SERVICE

**HOBART GMBH**

Robert-Bosch-Straße 17

77656 Offenburg/GERMANY

Phone +49(0)781.600-28 20

Fax +49(0)781.600-28 19

email: [info-export@hobart.de](mailto:info-export@hobart.de)

[www.hobart-export.com](http://www.hobart-export.com)

**EFFICIENT – RELIABLE – INNOVATIVE**

Member of the *ITW* Food Equipment Group Europe

