



BATTEUR MELANGEURS PLANETARY MIXERS

100 litres / 100 litres

BTA100FH

Fourni avec :
Supplied with:



Photos non contractuelles / Photos not contractual

- Tableau de commandes digital
- Variateur de vitesse
- Minuterie
- Levage de cuve motorisé
- Cuve inox renforcée et outils inox
- Blocage de cuve
- Grille de sécurité rotative
- Bec verseur sur grille
- Mise à niveau réglable, patins anti-vibrations
- Pieds en inox
- 400/50-60Hz/3
- Puissance : 4 kW
- Poids net : 612 kg

Options :

- Equipements de réduction - Racleur de cuve
- Chariot de cuve - Elévateur de cuve - Corps de machine en inox - Panneau de commande digital déporté
- Tableau de commandes programmable
- Modèle rabaissé
- Equipement de réduction 80 litres

- Digital control panel
- Multi speed system
- Timer
- Motorized bowl lifting
- Stainless steel strengthened bowl and tools
- Locking bowl
- Rotary safety grid
- Spout on grid
- Adjustable level, anti-vibration pads
- Stainless steel feet
- 400/50-60Hz/3
- Power : 4kW
- Net weight : 612 kg

Options :

- Additional equipments - Bowl scraper - Trolley for bowl
- Bowl lifter - Stainless steel frame
- Programmable touch screen control panel
- Remote digital control panel - Pulled down
- 80 litre additional equipment

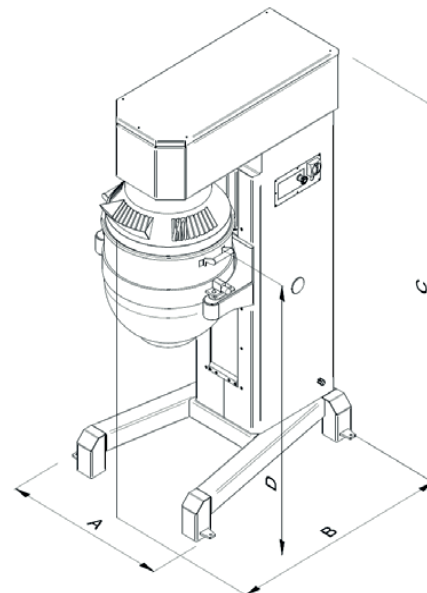

A = 920 mm
B = 1250 mm
C = 2085 mm
D = 1490 mm



www.caplainmachines.com



Caplain Machines



Caplain Machines



8 / 10 Rue Clément Ader
77170 Brie Comte Robert
France



+ 33 1 60 02 19 19