



BATTEUR MELANGEUR 10 LITRES 10 LITRE PLANETARY MIXER

BT10B



Photos non contractuelles / Photos not contractual

- 10 Litres
- Commandes électromécaniques
- Variateur de vitesse
- Panneau de commande avec potentiomètre
- Minuterie
- Corps de machine en acier peint
- Cuve inox
- Pieds surélevés
- Cuve fixe
- Protection en plexi
- Outils en inox
- 230/50Hz/1
- Puissance : 0.50 Kw
- Poids net : 47 kg

Options :

- 60Hz



- 10 Litre
- Electromechanical control panel
- Multi speed system
- Control panel with potentiometer
- Timer
- Body of machine in painted steel
- Stainless steel bowl
- Fixed bowl
- Plexi protection
- Stainless steel tools
- 230/50Hz/1
- Power : 0.50 Kw
- Net weight : 47 kg

Options :

- 60 Hz

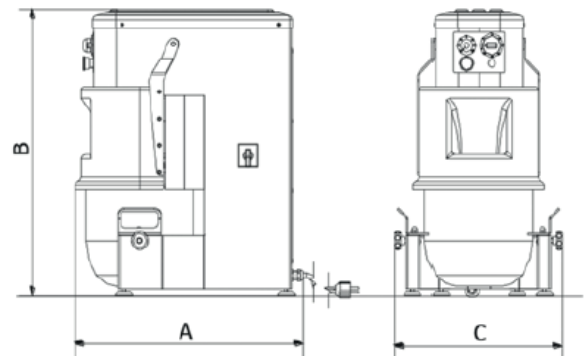

A = 550 mm
B = 640 mm
C = 400 mm

