



SOLUTION OF ENGINEERING



Currently Thailand industrial has continued development. Technologies & innovation are key factor to utilize for improve traditional process to be more accurate and increase productivity. One of important part in this development is quality control. Generally, shape, dimension and other requirement control of industrial parts must use tooling for inspection. Specific tooling will apply to use with specific application as some application require high precision up to micron. But how to maximize tooling efficiency and how to get right solution still concern by manufacturer.

General Corporation Co., Ltd. was established to serve this requirement. We are business consultant, provide professional service for support customers in term of Engineering. From our experience and knowledge which can support for high tech machinery, automation systems, hardware and software controller, inspection tooling with high precision scale, Jig & Fixture, Jig Position, Jig Spot, Assembly Jig, including hydraulic pneumatic clamping device, Line design, Conveyor system, Conveyor Free Roller, Industrial structure, Environment test, Project design, Prototype, 3D inspection & Reverse Engineer.

We have experienced engineering team who can help our customers to do engineering design, support for improve process, analyze and problem solving. We can support customers with latest technologies for both electric and mechanic, drawing design, program creator. We also can help to produce machine parts made to order, installation, benchmark and performance test, training, preventive maintenance along with after sales service to maximize customers satisfaction.

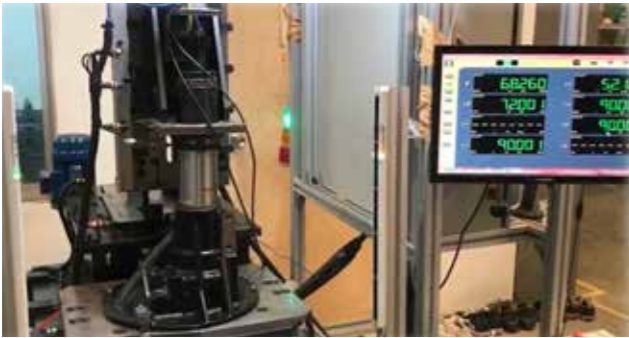

Quality Inspection Automatic Machine

- DIAMETER
- ROUNDNESS
- CONCENTRICITY
- DISTANCE
- POSITION
- FLATNESS

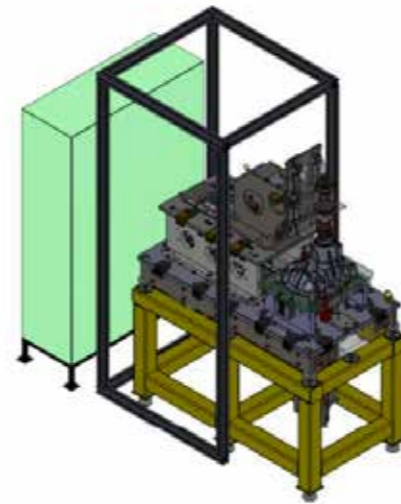
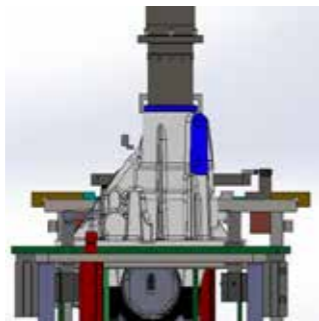

ISOMETRIC VIEW

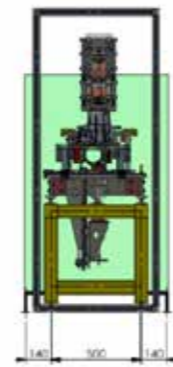
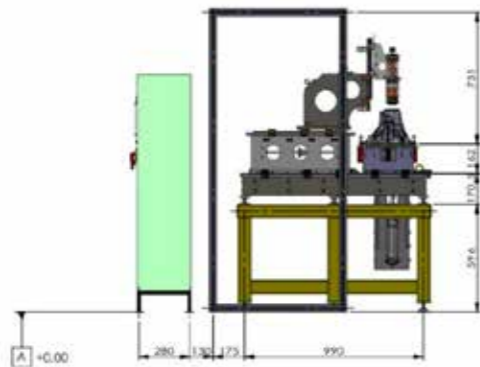

- Inspection cycle time: Cycle time 2 minutes
- Data from measuring can be load out from the machine
- Record system in the future can be support SCADA program
- Data from measuring can be transferred to QR Code system

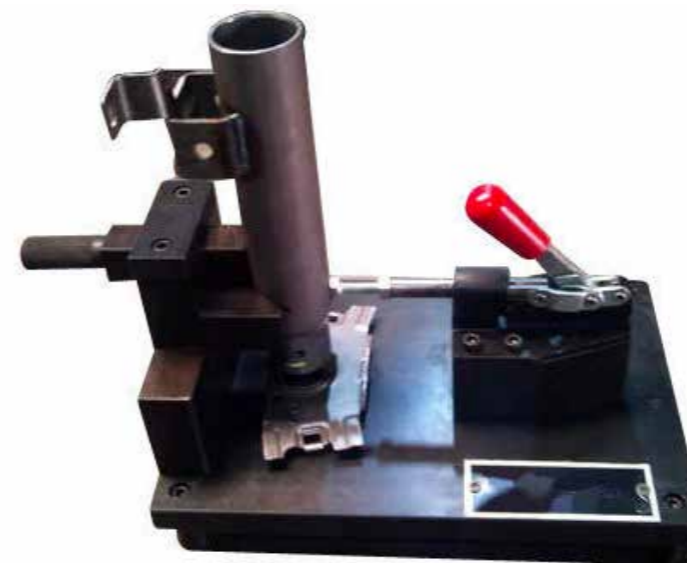

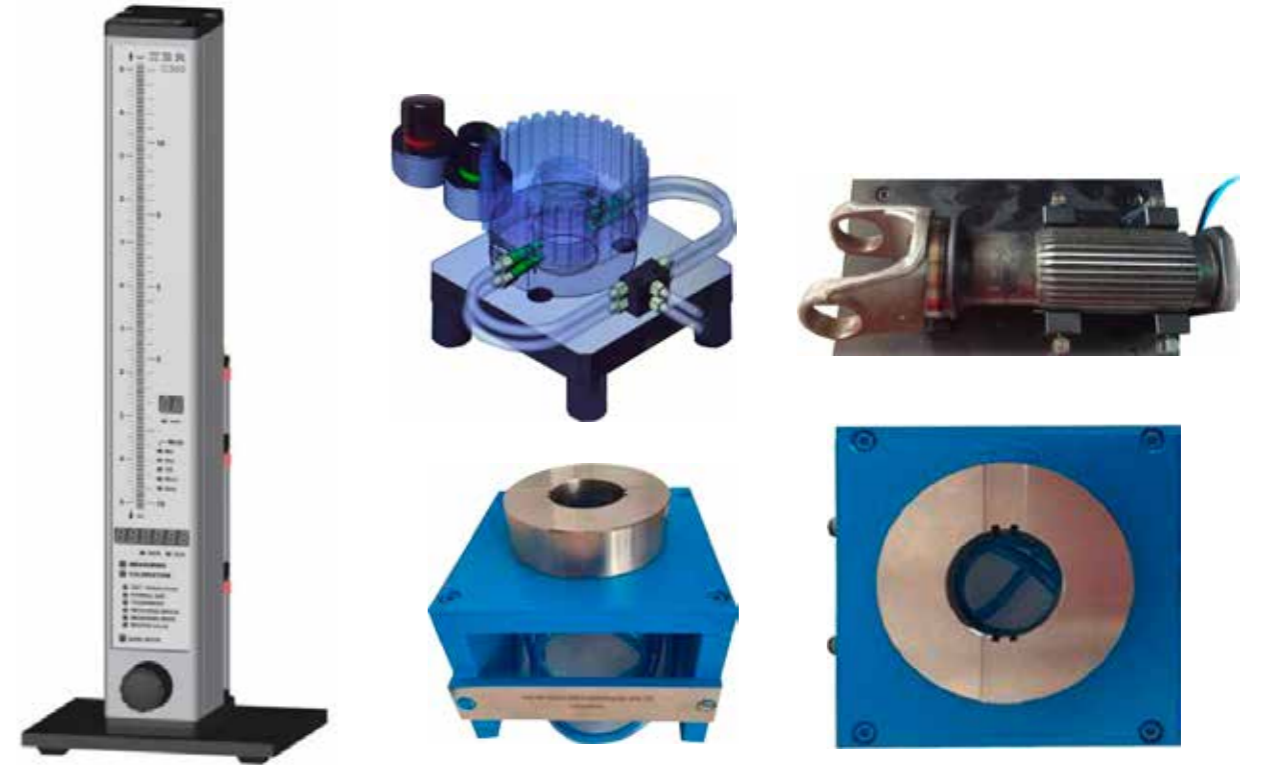
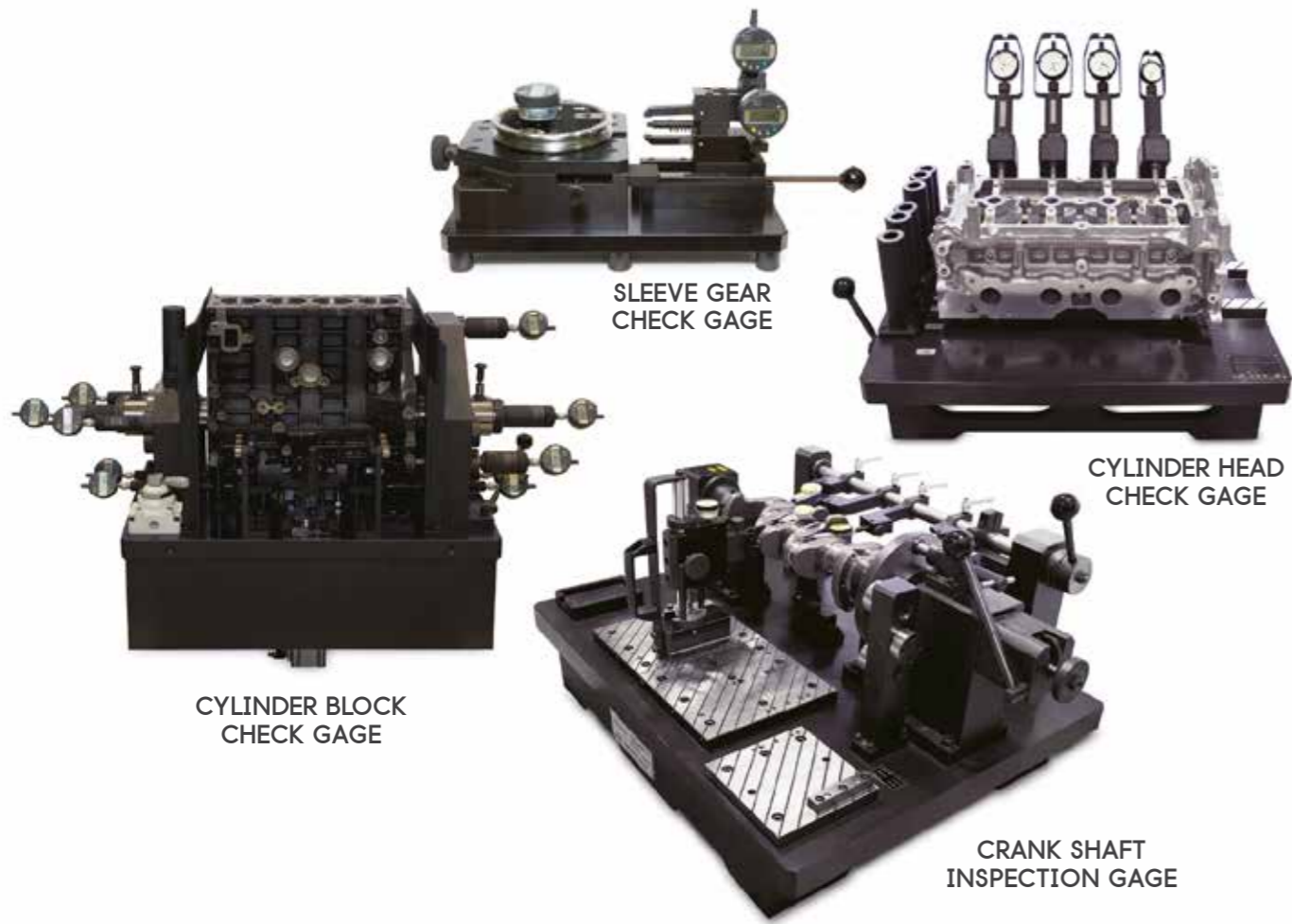

Special Gauge



Spline Gauge

SHB-2548 J-3251 GO GAUGE

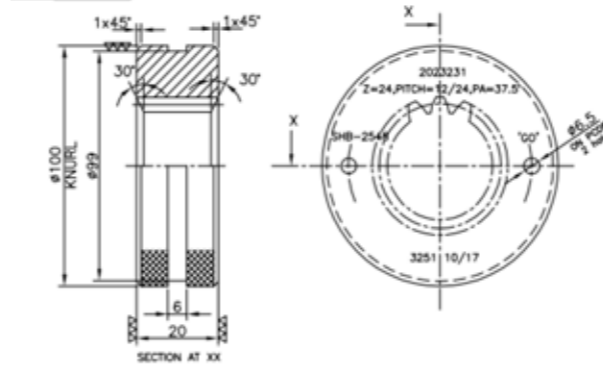

COMPONENT DATA EXTERNAL SPLINE		
MODULE(PITCH)	2.1166(12/24)	
PRESSURE ANGLE	37.5°	
NO. OF TEETH	24	
MAJOR DIA.	51.9938/51.4858	
MINOR DIA.	48.0060/47.6250	
PITCH DIA.	50.8000	
BASE DIA.	40.3023	
FORM DIA.(Ref.)	48.996	
C.T.T. EFFECTIVE MAX	3.5357	
C.T.T. ACTUAL	MAX	3.5027
	MIN	3.3757
DIM. OVER PINS	57.3433/57.1888	
PIN DIA.	4.0640	

SPLINE RING GO GAUGE DATA (FULL FORM TYPE)	
NO. OF SPLINE Z	24
MINOR DIA.	48.996/48.983
FORM DIA.(Ref.)	52.420
MAJOR DIA. (Ref.)	52.630
CULAR S. WIDTH	3.5307
DIMN. BET. PIN	43.349/43.343
PIN DIA.	4.500
WEAR LIMIT	
WEAR LIMIT S. WIDTH	3.5357
WEAR LIMIT BET. PIN	43.356

ALLOWABLE ERRORS FOR GO GAUGES	
PROFILE	0.005
SPACING	0.005
RUN OUT	0.0075
LEAD	0.0025



Drawing Sample

Bore Gauge & Smart Plug



SHB-780

J-985 TO 971

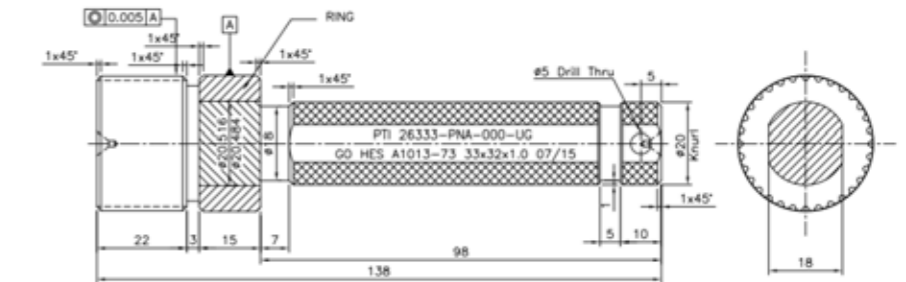

INV. SPLINE PLUGE GAUGE DATA	
NO. OF SPLINE	32
MODULE	1.0
PRESSURE ANGLE	37.5°
F.C.D.	32.000
B.C.D.	25.3873
MAJOR DIA.	32.800/32.761
MINOR DIA.	30.700 max
FORM DIA.(Ref.)	30.800
C.T.T. NEW	1.539
PIN DIA.	1.800
OVER PIN DIA. NEW	34.6555/34.6499
WEAR LIMIT C.T.T.	1.532
WEAR OVER PIN DIA.	34.6411

ALLOWABLE ERRORS FOR GO & NO GO GAUGES AS PER BS SIO 4156 2005	
PROFILE	0.005
PITCH	0.005
RUN OUT	0.007
LEAD	0.003

DRAWING FOR APPROVAL

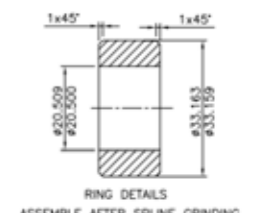

RING DETAILS
ASSEMBLE AFTER SPLINE GRINDING

Do not Scale
ALL DIMENSIONS ARE IN MM
BREAK SHARP EDGE AROUND SPLINE
ANY UNSTATED CHAMFER 1x45

Drawing Sample

OIP 21357

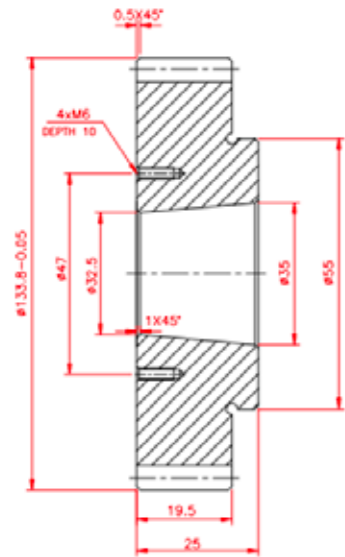

COMPONENT GEAR DATA		MASTER GEAR DATA	
NO OF TEETH Z	21	96	
Normal Module m	1.29	1.29	
Normal P.A. n	20°	20°	
H.A. & HAND	20°42'51" LH	20°42'51" RH	
P.C.D.	28.962	132.399	
B.C.D.	26.991	123.386	
Major diameter	31.70-0.2	133.8-0.05	
S.A.P. diameter	27.146	129.113	
Root diameter (Ref.)	25.216	127.5	
Dimension over pin	31.070 ±0.033	133.420 ±0.036	
Pin dia.	2.0	2.0	

MARK : 1.29NM 20°NPA 20°42'51" HA RH
Z-96 BCD 123.386MM M2
DIN 3962-1977, CLASS-4
PINION PLANET OTRG DH11665

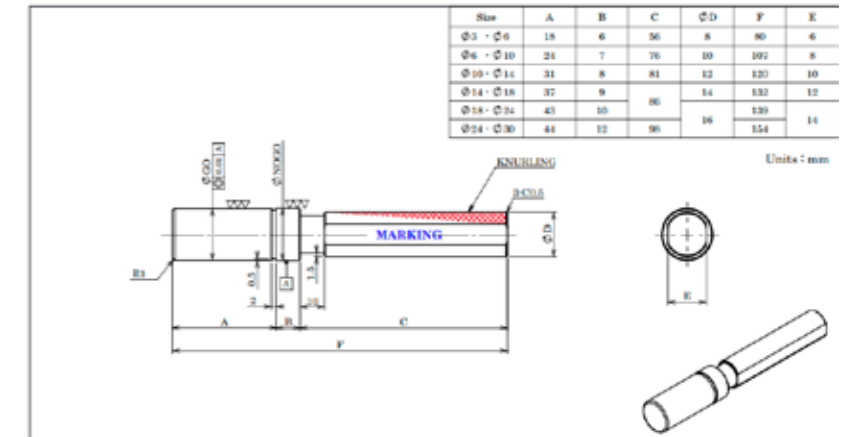

Tolerance ± 0.001 mm.

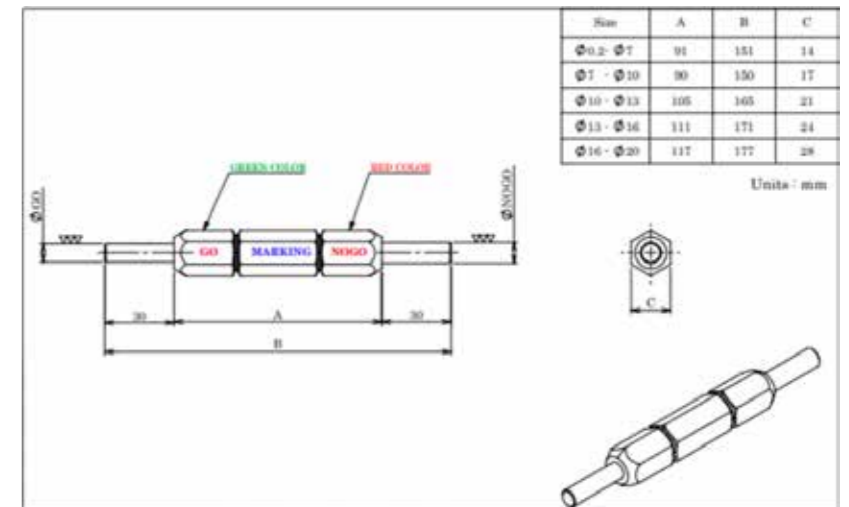
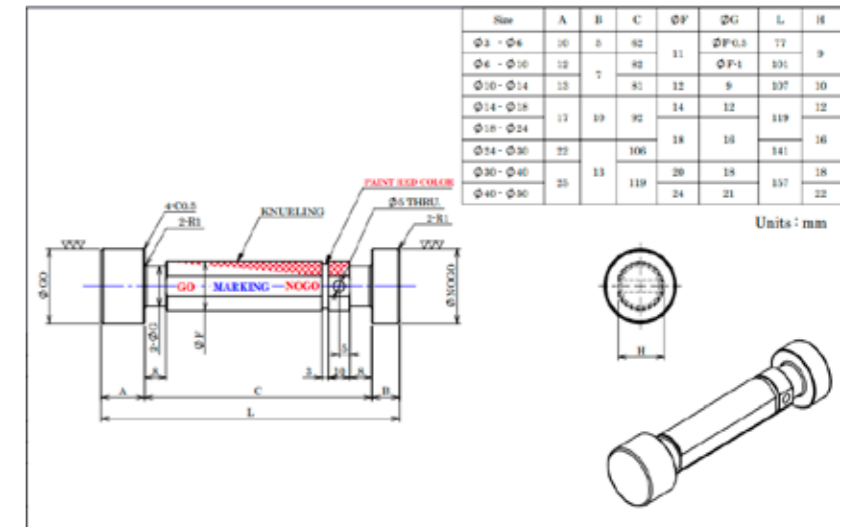

Snap Gauge

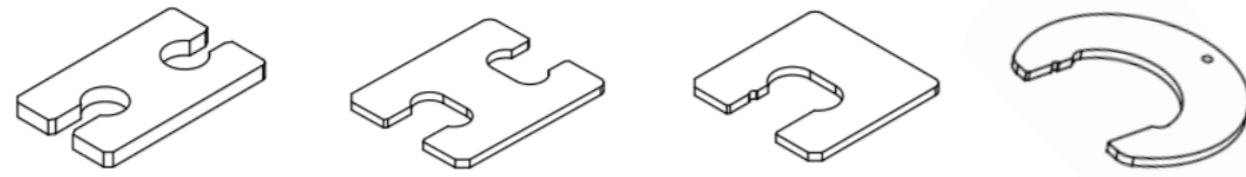

Tolerance ± 0.001 mm.

Ring Gauge

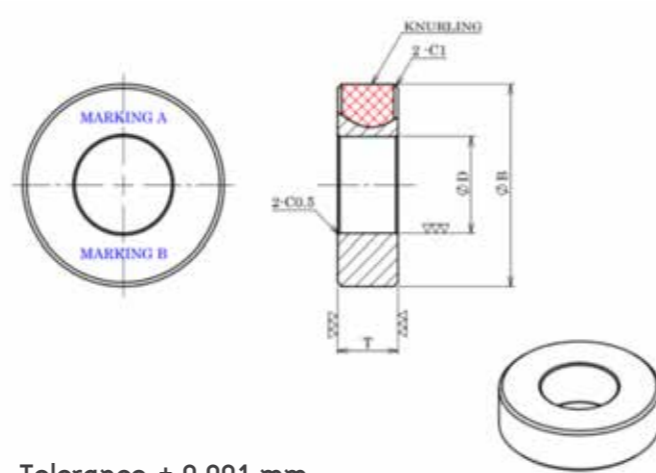

Tolerance ± 0.001 mm.



Limit Gauge



Pin Gauge / Steel



Pin Gauge / Carbide



Handle Reversible Double End



Handle Reversible Single End



Plug Gauge Reversible SE / Steel



Plug Gauge Reversible SE / Carbide



Plug Gauge Soild type / Steel



Plug Gauge Soild type / Carbide



Plug Gauge Taperlock / Steel



Plug Gauge Taperlock / Carbide



Plug Gauge Progressive / Steel



Plug Gauge Taperlock / Steel



Plug Gauge Soild type / Carbide



Plug Gauge Soild type / Carbide



Special Gauge Plug Gauge



Special Gauge Plug Gauge



Special Snap Gauge



Snap Gauge / Carbide



Core Pin



Taper Mandrel



Special Snap Gauge



Ring Gauge / GONOGO



Ring Gauge / Steel



Taper Plug Gauge



Snap Gauge SE / Steel



Special Ring Gauge



Ring Gauge / Carbide



Special Gauge



Precision Part



Spline Ring Gauge



Thread Ring Gauge



Thread Depth Gauge



Thread plug Gauge



Taper Ring Gauge



Thread Location Plug



Test Bar



Master Gear



Taper Spline Mandrel



Spline Plug Gauge



Boring Head

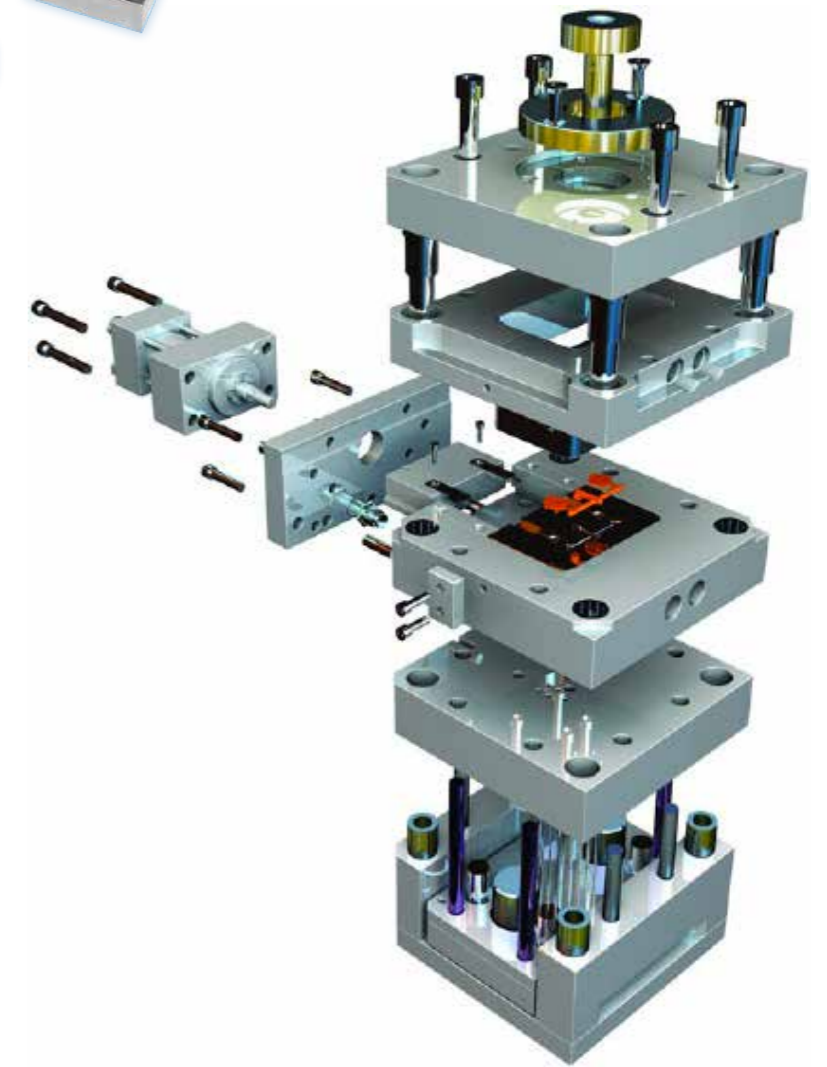

Air Micrometer, Air Measuring Head, Indicating Bore Gauge



Air Micrometer Flow Type



Air Micrometer Digital Type



Air Micrometer Digital Type

HEXAACON



Setting Ring Gauge



Special Air Gauge



Air Micrometer Dial Type



OD Gauge



Chamfer Gauge



OD Gauge



T-Probe



Air Snap Gauge



Air Plug Gauge



Air Ring Gauge



BMD Plug

System Integration, Position Gauge, Semi Auto Machine



Special Gauge

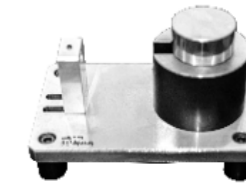

CF Gauge



Position Gauge



Inspection Machine



Robot



Robot Inspection



Vision System



Cognex Camera Vision



Automatic Assembly Machine



Semi Automatic Gauging System



Digital Dial Level Type



Dial Gauge



Digital Dial Gauge



Dial Gauge



CMM Stylus Probe



Ball Gauge



Renishaw



Vernier



Digital Vernier



Micrometer



Feeler Gauge



Digital Protractor



Torque Wrench

Bore Gauge



Portable Roughness



Portable Roughness



X-Y Stage



Screw Pitch Gauge



Magnetic Level Gauge



Magnetic Stand



Magnetic V Block



Concentric Stand



Dial Gauge Stand



Magnifying Lamp



Gap and Step Gauge



Torque Tester



Cast Iron Surface Plate



Granite Surface Plate



Stand



Bench Center



Standard Hardness



Depth Gauge

Faro Arm, X-Ray Machine



Climate Test Chambers



Industrial Ovens



X-Ray Machine



FARO Laser Tracker



FARO Arm

Measuring Machine



Shaft Tester Machine



Gear Tester



Roundness Tester



Digital Height Gauge



ULM Machine

Laboratory Testing



Cutting Machine



Electric Muffle Furnace



Salt Spray



Mounting Press



Viscometer



Ultrasonic Cleaner



Lab Drying Oven Environmental



Polishing Machine



Moisture Balance Analyzer



Homogenizer



Incubator



Dessicator



Spectrophotometer



Laboratory Table



Stainless Steel Laboratory



Leak Test Machine

Photo&Vision Systems, Force&Tension, Weight Scale



Profile Projector



Digital Microscope



Photo Sensor



Vision Sensor



Force Gauge



Digital Force Gauge



Load Cell



Load Cell



Weight Scale



Standard Weight



Hanging Scale



Weight Scale



Hardness Tester



Tension Machine



Universal Tension Machine



Bottle Cap Torque Tester

NACHI



Vertical Machining



CNC Lathe Machine



Wire Cut Machine



Chuck

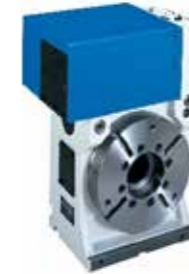

Rotary Table



Zero-Point Chuck

bitagawa



Clamping



Base point for Zero-Point Chuck



Hydraulic Clamping Fixture



Hydraulic Work



Gas Spring



Work Clamping

Machine Equipments



Vertical Band Saw Machine



Cutting Machine with End Grinder



Drill Resharpener Machine



Blow Feeder



Horizontal-Vertical Rotary Table



Lightweight Shelves



Tool Storage Case



Spot Cooler



Standard Demagnetizer



AGV



Auto Feed Screw



XY



Heavy Smoke



Punch Former

Aluminium Pipe System



Aluminium Pipe



Aluminium tube connectors



Plastic tube connector



Adjust Foot



Plastic Roller



Tool Holder Rack





Aluminium Profile



Bracket



Plate Bracket



Hinge



Handle



T-Nut



Wheel



Free Roller



Belt Conveyor



Ball Transfer



Modular Conveyor Belt



Hand Lift



Electric Pallet Truck



Portable Manual Hydraulic Small Scissor lift Table



Portable Manual Hydraulic



Folk Lift





Flow Meter



Mini-Softer



Short Tie Rod Hydraulic



Hydraulic Cylinder



Slide Unit



Gripper



Compact Cylinder



Pneumatic Fittings



Pressure Gauge



Digital Pressuer



Well Air



Regurator



Regurator Digital



Solenoid Valve



Fittings



Air Hose



Hydraulic Hose



Silencer



Hand Valve



Hydraulic Pump



Air Compressor



Data Logger



Gloss Meter



Light and UV Meter



CO2 Meter



Watt Clamp Meter



Digital Multimeter



PH Meter



Sound Level Meter



Humidity Meter



Particle Counter
ฝุ่นละออง PM2.5



Tachometer



Alcohol Breath Testers



Vibration Meter



Gas Detector



Energy Meter



Ultrasonic Thickness Gauge



High Precision Machine Reamers



Machine Taper Pin Reamers



Morse taper Reamers



Carbide Reamers



Tap



Deep Hole Tap



Straight Flute Tap



Special Tap Thread



Hand Valve & Foot Switch



Hand Valve & Foot Switch



Countersink



Counter Bore



Step Drill



Endmill

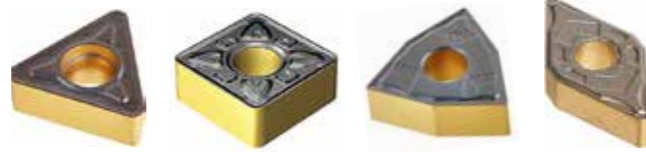

Insert



Knurling Wheel



Knurling Tool



Thread Rolling Die



Flat Thread Rolling Die



Gear Shaving Cutters



Involute Spline Hobs



Broach



Gear Hob



High Speed Center Lathe



BT Pull Stud



Mechanical Edge Finder



Center Lathe



Face Mill



ER Collet



Tuning Holder



Tuning Holder



Shell End Mill 90



Drill Chuck



BT Drill Chuck



BT Face Mill Holder



Lathe Machine Holder



Boring Head



Drill Sleeve



NT Face Mill Holder

Abrasive Tools, Die Components



Ceramic Grinding Wheel



WA Grinding Wheel



Carbide Grinding Wheel



Diamond Compounds



Boride AO Stone



เพชรกรัดหิน



Steel Die Set



Guide Bush



ตะไบเพชร



Integrated Guide Post Set



Air Balancer



Springs



Bi-Metal Blade



Air Grinders



Pneumatic Air Die Grinder



Electric Engraver

Maintenance Tools



Medium-Duty Shelves



Lightweight Shelves



Air Impact Wrenches



Electric Grinder



Box



Toggle Clamps



Special Clamp



Caster



Upward Ball Transfers



Gravity Steel Roller Conveyors



Lifters Pallet Trucks



Abrasive Belts



Sealing Materials



Sealants



Steel Die Set



Guide Bush



ตะไบเพชร



Integrated Guide Post Set



Air Balancer



Springs



Bi-Metal Blade



Air Grinders



Pneumatic Air Die Grinder



Electric Engraver



Cart



Carbide Burs



Drums Bands



Files



Screwdriver with Plastic Handle



Air Screwdrivers for Slowdown



Diamond Burrs



Ball-Point Hexagon Wrenches



Screwdriver



Diamond Files

Maintenance Tools

Maintenance Tools



Electric Equipments

Electric Equipments



Quick Splice



Switch



Pilot lamp



Terminal and Code End



Wire Nut Connector



Optical Network Unit



Router



Worm Gear



Power Cable



Dust Respirators



AC Servo Drive



Touchscreen



Proxy Switch



CLS Limit Switch



Temperature Controller



Counter



Breaker



Breaker Box



Controller



Network Storage



TZ Limit Switch



Ethernet Switches



Optical Line Termination (OLT)



Wireduct



Air Condition for Control Boxes



Magnetic Contactor



Server Box



AGV



Servo Motor



Thermocouple



Immersion Heater



Tower Lamp



Power Supply



PLC Mitsubishi



PLC Omron



Motor



Rotary Encoder



Pressure Switch



Cloud System



Solid State Relay



Overload Relay



Inverter Mitsubishi



CCTV Server



Ac Axial Fan



Fuse Box



Relay



Lan Cable

Electric Equipments



Binocular Face ID

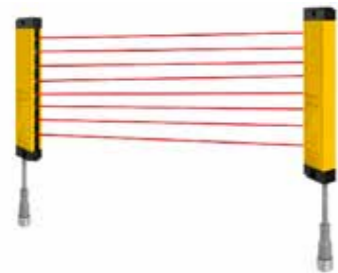

Area sensor



Turnstile Gate



CCTV Camera



Vision System



IP Camera



Photo Sensor



Barcode Scanner



Barcode Reader



Barcode Printer



Thermal Barcode Sticker



Paper Barcode Sticker



LED Solar Cell Street Light



Solar LED Light



Bower



3D Printer



Solar Cell



LED Highbay 150

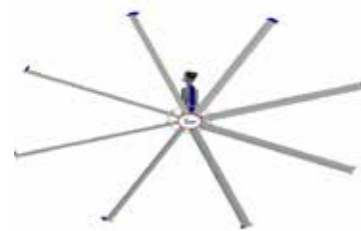

Big Fan

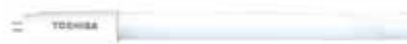

LED Tube T5 8W, 16W TOSHIBA



LED PAR20, PAR30, PAR38



LED Bulb T5 8W, 16W TOSHIBA

Safety Products



Protective Clothes



Single-Lens Safety Glasses



Two-Lens type Safety Glasses



Laser Safety Glasses



Safety Goggles



Arm Bands



Earplugs



Earmuffs



Cotton Work Gloves



Helmets



Helmets for light work



Disposable Particulate Respirators



General-Purpose Masks



Faceshields



Dust Respirators



Gas Respirators



Safety Cone



Boots



Safety Boots



Safety Belts and Harnesses



Goods for Helmet



Safety Work Shoes



Protective Sneakers



Safety Ropes

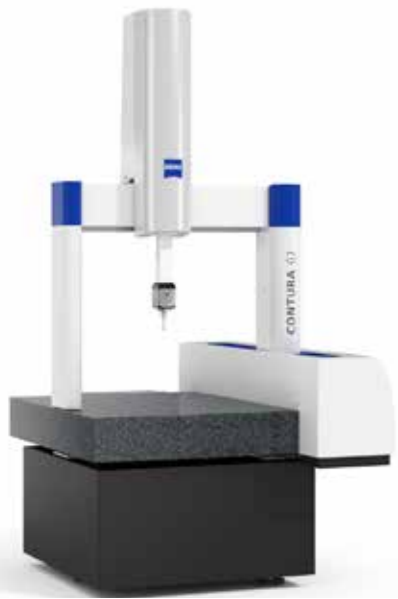



ID LINE: SALES.GENCORP

บริษัท เจนเนอรัล คอร์ปอเรชั่น จำกัด
GENERAL CORPORATION CO., LTD.



0-2720-7910
091-740-7354



sales.generalcorp@gmail.com
sales1.generalcorp@gmail.com



6/79 หมู่ที่ 2 ซอยเรวัติ 60 ถนนเรวัติ ตำบลคณาษฎ์
อำเภอเมืองนนทบุรี จังหวัด นนทบุรี 11000