

Smart IoT Series Biosafety Cabinets

HR1200-IIA2-X
HR1500-IIA2-X
HR1800-IIA2-X



Main Applications

Professional localized air purification equipment suitable for pharmaceuticals, medical and health industries and scientific research laboratories of universities and colleges as well as other related fields



Specifications

Model		HR1200-IIA2-X	HR1500-IIA2-X	HR1800-IIA2-X
Power(VA)		1600	1670	1850
Downflow Velocity		0.30	0.30	0.30
Inflow Velocity		0.45	0.45	0.45
Net/Gross Weight (approx)	kg	280/340	320/400	380/465
	lbs	617.3/749.6	705.5/881.8	837.8/1025.1
Internal Dimension (W*D*H)	mm	1230*600*655	1530*600*655	1830*600*655
	in	48.4*23.6*25.8	60.2*23.6*25.8	72.0*23.6*25.8
External Dimension (W*D*H)	mm	1336*790*2120	1636*790*2120	1936*790*2120
	in	52.6*31.1*83.5	64.4*31.1*83.5	76.2*31.1*83.5
Packing Dimension (W*D*H)	mm	1400*925*1665	1700*925*1665	2000*925*1665
	in	55.1*36.4*65.6	66.9*36.4*65.6	78.7*36.4*65.6
Container Load(20'/40'/40'H)		8/16/16	6/12/12	6/12/12

Product dimension

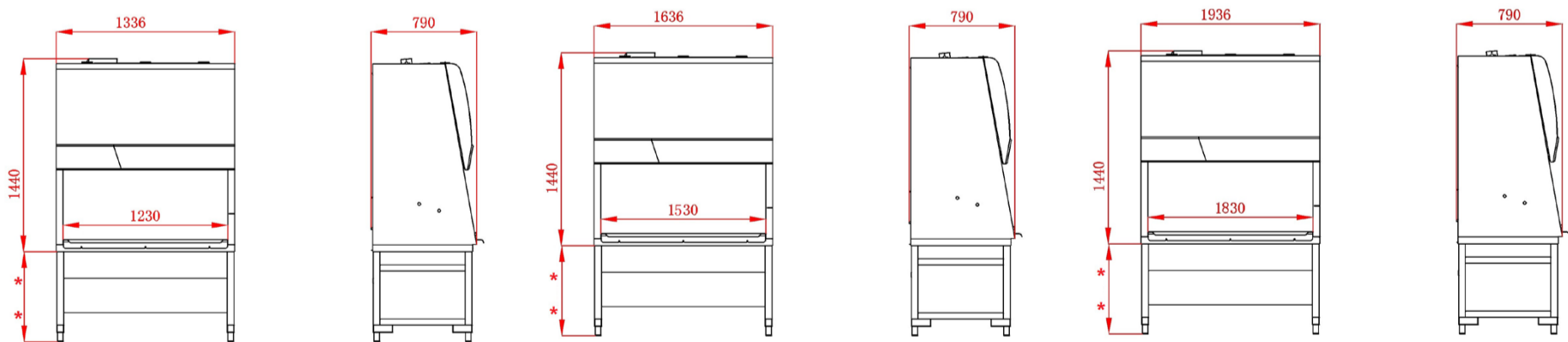

HR1200-IIA2-X

HR1500-IIA2-X

HR1800-IIA2-X

**means the adjustable stand ranges from 680mm to 900mm.

